

# EFFICIENCY EVALUATION OF EXTERNAL ENVIRONMENTS CONTROL USING BIO-SIGNALS

Aleksandra Kawala-Janik

A thesis submitted in partial fulfilment of the  
requirements of the University of Greenwich  
for the Degree of Doctor of Philosophy

January 2013

## **Declaration**

I certify that this work has not been accepted in substance for any degree, and is not concurrently being submitted for any degree other than that of Doctor of Philosophy being studied at the University of Greenwich. I also declare that this work is the result of my own investigations except where otherwise identified by references and that I have not plagiarised the work of others.

Student:

1st Supervisor:

## **Abstract**

There are many types of bio-signals with various control application prospects. This dissertation regards possible application domain of electroencephalographic signal. The implementation of EEG signals, as a source of information used for control of external devices, became recently a growing concern in the scientific world. Application of electroencephalographic signals in Brain-Computer Interfaces (BCI) (variant of Human-Computer Interfaces (HCI)) as an implement, which enables direct and fast communication between the human brain and an external device, has become recently very popular. Currently available on the market, BCI solutions require complex signal processing methodology, which results in the need of an expensive equipment with high computing power.

In this work, a study on using various types of EEG equipment in order to apply the most appropriate one was conducted. The analysis of EEG signals is very complex due to the presence of various internal and external artifacts. The signals are also sensitive to disturbances and non-stochastic, what makes the analysis a complicated task. The research was performed on customised (built by the author of this dissertation) equipment, on professional medical device and on Emotiv EPOC headset.

This work concentrated on application of an inexpensive, easy to use, Emotiv EPOC headset as a tool for gaining EEG signals. The project also involved application of embedded system platform – TS-7260. That solution caused limits in choosing an appropriate signal processing method, as embedded platforms characterise with a little efficiency

and low computing power. That aspect was the most challenging part of the whole work.

Implementation of the embedded platform enables to extend the possible future application of the proposed BCI. It also gives more flexibility, as the platform is able to simulate various environments.

The study did not involve the use of traditional statistical or complex signal processing methods. The novelty of the solution relied on implementation of the basic mathematical operations. The efficiency of this method was also presented in this dissertation. Another important aspect of the conducted study is that the research was carried out not only in a laboratory, but also in an environment reflecting real-life conditions.

The results proved efficiency and suitability of the implementation of the proposed solution in real-life environments. The further study will focus on improvement of the signal-processing method and application of other bio-signals – in order to extend the possible applicability and ameliorate its effectiveness.

...I dedicate this work to my late grandparents - Ireneusz Rakoczy,  
Krystyna & Jan Kawala,  
and to my beloved, wonderful son – Jakub Tomasz Janik – born on  
20th November 2012...

## Acknowledgements

I would like to thank my family - my parents Beata and Grzegorz Kawala, my beloved husband - Przemyslaw Janik and my grandmother – Irena Rakoczy, for their love during my work on this dissertation.

I would also like to thank my supervisors Dr Mariusz Pelc, Dr Richard Anthony and Dr Jixin Ma for their constant support and belief in my work and skills. Very special thanks for Mariusz, who has spent with me numerous hours and constantly convinced me not to give up. Richard, thank you for reading parts of my work with so much patience – at least twice a week – it took you so much time, thank you once again. Jixin – thank you for improving my work environment, it helped me so much, I do appreciate it so much, that is hard to express.

Sincere thanks also to Professor Dariusz Zmarzly, Professor Marian Lukaszyn from the Opole University of Technology for their assistance during my studies there and help with the transfer.

I cannot also forget about Professor Bernard Baron and Dr. Michal Lewandowski from the Silesian University of Technology, who enabled me to conduct my first EEG-based research and provided me with a lot valuable data and information.

I would also like to thank Prof. Koulis Pericleous for his support and help during my transfer from the Opole University of Technology.

# Contents

<b>List of Figures</b>	<b>vii</b>
<b>List of Tables</b>	<b>xvi</b>
<b>1 Introduction</b>	<b>1</b>
1.1 Background to the Study . . . . .	2
1.2 Methodology . . . . .	2
1.3 Research Questions . . . . .	4
1.4 Chapters of the Dissertation . . . . .	4
<b>2 Literature Review</b>	<b>7</b>
2.1 Brain-Computer Interfaces . . . . .	7
2.2 Overview of Existing Solutions . . . . .	17
2.3 The Newest Trends in Brain-Computer Interfaces . . . . .	21
2.3.1 Emotiv-based Brain-Computer Interfaces . . . . .	34
2.4 Various Human-Computer Interfaces . . . . .	38
2.4.1 Electromyography-based Human-Computer Interfaces . . . . .	38
2.4.2 Electrooculography-based Human-Computer Interfaces . . . . .	42
2.5 Summary of the Literature Review . . . . .	43
<b>3 Theoretical Background</b>	<b>47</b>
3.1 The Nervous System . . . . .	47
3.1.1 Neuron . . . . .	48
3.1.2 How do neurons work? . . . . .	55
3.1.3 Glia . . . . .	62
3.1.4 Central Nervous System (CNS) . . . . .	64

3.1.4.1	Brain . . . . .	66
3.1.4.2	Spinal Cord . . . . .	74
3.1.5	Pyramidal Nerves . . . . .	79
3.2	Electrical Activity of Brain - Measurement Methods . . . . .	86
3.2.1	Electroencephalography . . . . .	86
3.2.1.1	Description of the Main EEG Rhythms . . . . .	91
3.2.1.2	Functional States of the Human Brain . . . . .	97
3.2.1.3	The Electrode Placement Systems . . . . .	100
3.2.1.4	Artifacts in the EEG Signals . . . . .	105
3.2.2	Event-Related Potentials . . . . .	107
3.2.3	Magnetoencephalography Versus Electroencephalography . . . . .	109
<b>4</b>	<b>Signal Processing - Overview</b>	<b>114</b>
4.1	Signal Processing Methodology . . . . .	114
4.1.1	Filtering . . . . .	118
4.1.2	Other Filters Applied in EEG Signal Processing – Spatial Filtration . . . . .	125
4.1.3	Wavelet Systems . . . . .	126
4.1.4	Transforms . . . . .	126
4.1.5	Time-Frequency Signal Processing . . . . .	128
4.1.6	Independent Component Analysis . . . . .	129
4.1.7	Principal Component Analysis . . . . .	129
<b>5</b>	<b>Pilot Study Using Customised Equipment for BCI System</b>	<b>130</b>
5.1	Rationale for a Study – Using Customised Equipment . . . . .	130
5.2	Objectives and Expected Results – Using Customised Equipment . . . . .	132
5.3	Research Methodology Applied – Using Customised Equipment . . . . .	132
5.4	Implementation – Using Customised Equipment . . . . .	133
5.5	Data Acquisition – Using Customised Equipment . . . . .	144
5.6	Results Evaluation – Using Customised Equipment . . . . .	147
5.7	Discussion – Using Customised Equipment . . . . .	155



<b>6</b>	<b>Use of Clinical EEG Equipment for BCI System</b>	<b>157</b>
6.1	Rationale for a Study – Using Clinical EEG Equipment . . . . .	157
6.2	Objectives and Expected Results – Using Clinical EEG Equipment	158
6.3	Research Methodology – Using Clinical EEG Equipment . . . . .	159
6.3.1	Implementation – Using Clinical EEG Equipment . . . . .	160
6.4	Data Acquisition – Using Clinical EEG Equipment . . . . .	162
6.5	Results Evaluation – Using Clinical EEG Equipment . . . . .	166
6.6	Discussion – Using Clinical EEG Equipment . . . . .	169
 <b>7</b>	 <b>Use of Emotiv Headset for BCI System</b>	 <b>171</b>
7.1	Rationale for a Study – Using Emotiv Headset . . . . .	171
7.2	Objectives and Expected Results – Using Emotiv Headset . . . . .	172
7.3	Research Methodology – Using Emotiv Headset . . . . .	172
7.4	Implementation – Using Emotiv Headset . . . . .	172
7.4.1	Decision-making Process Based on Signal Processing . . . . .	173
7.4.2	Implemented Applications . . . . .	175
7.5	Data Acquisition – Using Emotiv Headset . . . . .	180
7.6	Results Evaluation – Using Emotiv Headset . . . . .	182
7.6.1	Filtering for the Research Purposes . . . . .	187
7.7	Discussion – Using Emotiv Headset . . . . .	203
 <b>8</b>	 <b>Conclusions and Further Work</b>	 <b>206</b>
8.1	Contribution of Research . . . . .	206
8.2	Further Work . . . . .	208
 <b>References</b>		 <b>211</b>
 <b>A</b>	 <b>Participant Information</b>	 <b>223</b>
 <b>B</b>	 <b>Selected Papers</b>	 <b>226</b>
 <b>C</b>	 <b>Applications Codes</b>	 <b>244</b>
C.1	Script for the Signal Processing Purposes – full code . . . . .	244
C.2	PC Application – C# . . . . .	248
C.3	Matlab Application . . . . .	253

## CONTENTS

---

C.4 Embedded Application – C . . . . .	255
<b>D Tables with Results</b>	<b>258</b>

# List of Figures

2.1	The growth of publications regarding BCI [3]. . . . .	8
2.2	Main types of applications controlled by BCI output [3]. . . . .	9
2.3	Three different methods for electrical activity of brain recordings [6]. . . . .	10
2.4	Brain activity recording methods [9]. . . . .	11
2.5	Range of electro-physiological measurement methods [3]. . . . .	12
2.6	Block diagram of a neural prosthesis [11]. . . . .	12
2.7	Neuro-prosthesis that can be controlled via BCI [6]. . . . .	13
2.8	Muscle-based and BCI-based CNS actions [3]. . . . .	14
2.9	Net with electrodes implemented on the surface of a monkey's brain [12]. . . . .	14
2.10	Matthew Nagle moving a cursor with his thoughts [14]. . . . .	15
2.11	Microelectrode – Cyberkinetics' team design [11]. . . . .	16
2.12	Scheme of a moving implant [15]. . . . .	17
2.13	Sample EEG-based BCI [6]. . . . .	18
2.14	10-20 electrodes placement system – scalp and cross-section [6, 16].	18
2.15	Various EEG-based BCIs [6]. . . . .	20
2.16	Example of two complex BCI applications – Rolland III and FRIEND II [6]. . . . .	21
2.17	Possible IGUI-BCI implementation [17]. . . . .	22
2.18	Brain-Computer Interface as a communication prosthesis [19, 20].	23
2.19	Exogenous interface implementation [19]. . . . .	24
2.20	Endogenous interface implementation [19]. . . . .	24

## LIST OF FIGURES

---

2.21	User controlling home appliances with implementation of P300 BCI [25]. . . . .	26
2.22	Signal acquisition setup [20]. . . . .	26
2.23	Spatial (left) and temporal (right) patterns of P300 component [20].	27
2.24	Graphical User Interface of the P300-based BCI [20]. . . . .	28
2.25	Interface of a 'Free P300-speller' designed by Guger Technologies [24]. . . . .	28
2.26	A participant interacting with the multi-touch P300-based BCI [23].	29
2.27	Image-processing pipeline – raw background image from camera showing the underside of the table (top-left), cropped and rectified image with four objects (top-right), after background removal, thresholding and filtering, four connected components (blobs) are detected and labeled (bottom) [23]. . . . .	30
2.28	BCI-based navigation in complex Virtual Environment (VE) [26].	31
2.29	Wearable BCI setup [27]. . . . .	32
2.30	Work-flow for establishing a secure VNC connection to a computer terminal after the terminal has been identified using BCI [27]. . .	33
2.31	Participant using Emotiv [29]. . . . .	35
2.32	A user wearing Emotiv EPOC during Superflick task performance [32]. . . . .	36
2.33	NeuroPhone system [34]. . . . .	37
2.34	P300-based Graphical User Interface of NeuroPhone [34]. . . . .	37
2.35	EMG sensors placement [35]. . . . .	39
2.36	EMG electrodes placement [36]. . . . .	40
2.37	Portable accelerometers and EMG sensors [37]. . . . .	41
2.38	EOG-based eye tracker with its components [38]. . . . .	42
2.39	Snapshot of custom document browser [39]. . . . .	43
2.40	BCI concept map [6]. . . . .	45
2.41	BCI output – goal selection [3]. . . . .	46
2.42	BCI output – process control [3]. . . . .	46
3.1	Basic scheme of the human nervous system [43]. . . . .	49
3.2	Functional components in the human nervous system [44]. . . . .	50

## LIST OF FIGURES

---

3.3	Basic parts of a single neuron [13, 51]. . . . .	50
3.4	A typical human neuron [45, 49]. . . . .	51
3.5	Various types of neurons [46, 52]. . . . .	52
3.6	Schematic presentation of dendrites spreading in a neuron [45]. . .	53
3.7	Structural classification of nerve cells [48, 53]. . . . .	54
3.8	Synaptic transmission in a nerve cell [46]. . . . .	58
3.9	Chemical synaptic transmission in a nerve cell [48, 50]. . . . .	59
3.10	Structure of an electrical synaptic transmission [50]. . . . .	60
3.11	Structure of a connexic connection [50]. . . . .	61
3.12	Connexon in an open and closed state [50]. . . . .	62
3.13	Schema of an Astrocyte [45, 49]. . . . .	63
3.14	Schema of an Oligodendrocyte [45, 49]. . . . .	64
3.15	Schwann cell wrapped around an axon [49]. . . . .	65
3.16	Central Nervous System main parts [61]. . . . .	66
3.17	Midsagittal section of the human brain [62]. . . . .	67
3.18	Lateral surface of the brain [62]. . . . .	67
3.19	Basal surface of the brain [62]. . . . .	68
3.20	The main division of the CNS [62]. . . . .	69
3.21	Section of the human brain [43]. . . . .	70
3.22	Lobes in human brain [43]. . . . .	70
3.23	Diagram of functional areas of a human brain [64]. . . . .	71
3.24	Lateral surface of the human brain [59]. . . . .	72
3.25	Brodmann's areas [65]. . . . .	73
3.26	Sample segment of the spinal cord cross section [66]. . . . .	75
3.27	The motor neurons distributed in the spinal cord [13]. . . . .	76
3.28	Cross section of the spinal cord [43]. . . . .	77
3.29	The spinal cord [43]. . . . .	78
3.30	Topographic relations of the spinal cord segments [62]. . . . .	80
3.31	Sample Pyramidal Neuron [13]. . . . .	81
3.32	Motor control - concept [48]. . . . .	82
3.33	Action potential in a pyramidal neuron [12]. . . . .	83
3.34	Distribution of the axon terminals in the pyramidal cell of hippocampus [71]. . . . .	84

## LIST OF FIGURES

---

3.35	Axon branches in the pyramidal neuron [72]. . . . .	85
3.36	First EEG signal recorded by Hans Berger in 1929 [74]. . . . .	87
3.37	Scheme of EEG-signal recording [72]. . . . .	89
3.38	EEG signals generation [13]. . . . .	90
3.39	Electroencephalograph recording electrical activity of brain [15]. .	91
3.40	Sample EEG characteristics [4]. . . . .	92
3.41	Main EEG rhythms as a time function [81]. . . . .	92
3.42	Alpha-rhythms potential waveforms recorded recorded along the mid-line [72]. . . . .	93
3.43	Sample analysis of the brain activity based on ICA (Independent Component Analysis) [69]. . . . .	96
3.44	Sample EEG – alpha- and beta- rhythms [13]. . . . .	97
3.45	EEG signal recorded in various state of subject: excited, relaxed and asleep [76]. . . . .	98
3.46	EEG frequency bands [69]. . . . .	99
3.47	Sample EEG signal recorded during sleep [13]. . . . .	101
3.48	Standard international 10-20 system [11]. . . . .	102
3.49	Expanded 10-20 system – known as 10-10 system [11, 84]. . . . .	103
3.50	Participant with a Sensor Net of 128 EEG electrodes and with some additional placed on cheeks and near the eyes [76]. . . . .	104
3.51	Electrodes-caps and montages [72]. . . . .	105
3.52	Sample of typical EEG artifacts [72]. . . . .	106
3.53	Presence of ERPs while hearing a sound [4]. . . . .	108
3.54	Evoked Potential as a result of hearing a tone [15]. . . . .	108
3.55	Brain activity imaging – basic scheme [4]. . . . .	110
3.56	Additive ERP model [72]. . . . .	111
3.57	Magnetic detectors in MEG [13]. . . . .	111
3.58	Sample magnetic detectors in MEG [12]. . . . .	112
3.59	Sample map of neural activity [13]. . . . .	113
4.1	Basic scheme of signal processing and classification [6]. . . . .	115
4.2	Basic signal classification [90]. . . . .	116
4.3	Sample random (stochastic) signal [90]. . . . .	117

## LIST OF FIGURES

---

4.4	Approximate modulus characteristic of a sample high-pass filter [90].	119
4.5	Modulus characteristic for a sample digital low-pass filter [90]. . .	120
4.6	Approximate modulus characteristic of a sample band-pass filter [90]. . . . .	120
4.7	Approximate modulus characteristic of a sample (notch) band-stop filter [90]. . . . .	121
4.8	Chebyshev I filter [94]. . . . .	122
4.9	Sample EEG signal filtered in the time-domain [5]. . . . .	123
4.10	Simplified Butterworth filter design for particular frequency band [95]. . . . .	124
4.11	Digital filters classification [90]. . . . .	125
4.12	FFT computation sample scheme [89]. . . . .	127
4.13	Sample discrete-time system [91]. . . . .	128
5.1	Schema of data flow in the system. . . . .	134
5.2	C3 and C4 - electrodes placement. . . . .	136
5.3	Customised equipment – basic scheme. . . . .	136
5.4	Electric circuit in the active electrode. . . . .	137
5.5	PSPICE – interface [110]. . . . .	138
5.6	Active electrode – etched cooper plate. . . . .	139
5.7	Customised, portable EEG – one electrode and the control module – in production phase. . . . .	141
5.8	Customised EEG – mounting system. . . . .	142
5.9	The device placed on a female head. . . . .	142
5.10	Active electrode. . . . .	143
5.11	Control module. . . . .	143
5.12	EEGLAB – interface [107]. . . . .	145
5.13	Scroll plot-components – sample window [107]. . . . .	146
5.14	Experiment – basic scheme. . . . .	146
5.15	Sample time progress of EEG signals – C3 and C4 electrodes. . .	147
5.16	Sample time progress of EEG signals – C3 and C4 electrodes – stimulus 1. . . . .	148

## LIST OF FIGURES

---

5.17	Sample time progress of EEG signals – C3 and C4 electrodes – stimulus 2. . . . .	148
5.18	Probability density function – stimulus 1. . . . .	149
5.19	Probability density function – stimulus 2. . . . .	150
5.20	Cross-Covariance Function – C3 and C4 electrodes – both stimuli.	150
5.21	Cross-Covariance Function – C3 and C4 electrodes – both stimuli – normalised form. . . . .	151
5.22	Spectral Density – C3 and C4 electrodes – stimulus 1. . . . .	151
5.23	Spectral Density – C3 and C4 electrodes – stimulus 2. . . . .	152
5.24	Spectral Density – C3 – both stimuli. . . . .	153
5.25	Spectral Density – C4 – both stimuli. . . . .	153
5.26	Wavelet Transform – Morlet – C3 and C4 – stimulus 1. . . . .	154
5.27	Wavelet Transform – Morlet – C3 and C4 – stimulus 2. . . . .	155
6.1	KT88-1016 – device [113]. . . . .	160
6.2	KT88-1016 – software interface [114]. . . . .	161
6.3	Neurofax – device [115]. . . . .	162
6.4	'Subject A' during experiment. . . . .	163
6.5	'Subject B' during experiment. . . . .	163
6.6	Visual stimulus – screen-shot. . . . .	164
6.7	FDA tool – user interface. . . . .	165
6.8	Raw signal recorded from C4 electrode – left hand movement. . .	166
6.9	Filtered signal recorded from C4 electrode – left hand movement.	167
6.10	Raw signal recorded from C3 electrode – right hand movement. .	168
6.11	Raw signal recorded from C3 electrode – right hand movement. .	168
6.12	Improved KT88-1016 software interface [113]. . . . .	170
7.1	Emotiv EPOC headset [31]. . . . .	173
7.2	Block Scheme of Client-Server Application. . . . .	176
7.3	TS-7260 board. . . . .	177
7.4	Screen-shot of working applications. . . . .	179
7.5	Task 1 – imaginary left hand movement. . . . .	180
7.6	Task 2 – imaginary right hand movement. . . . .	181
7.7	Task 3 - relax. . . . .	181



## LIST OF FIGURES

---

7.8	Subject with Emotiv EPOC headset during experiment. . . . .	182
7.9	Electrodes used for the research purpose. . . . .	183
7.10	Imaginary left-hand movement – 'F4'-electrode – quiet environment – raw signals. . . . .	184
7.11	Imaginary left-hand movement – 'F4'-electrode – quiet environment – raw signals – scaled view. . . . .	185
7.12	Single-sided amplitude spectra of the signals. . . . .	185
7.13	Single-sided amplitude spectra of the signals – scaled view. . . . .	186
7.14	Imaginary left-hand movement – 'F4'-electrode – noisy environment – raw signals. . . . .	187
7.15	Imaginary left-hand movement – 'F4'-electrode – noisy environment – raw signals – scaled view. . . . .	188
7.16	Imaginary right-hand movement – 'F3'-electrode – quiet environment – raw signals. . . . .	189
7.17	Imaginary right-hand movement – 'F3'-electrode – quiet environment – raw signals – scaled view. . . . .	190
7.18	Imaginary right-hand movement – 'F3'-electrode – noisy environment – raw signals. . . . .	191
7.19	Imaginary right-hand movement – 'F3'-electrode – noisy environment – raw signals – scaled view. . . . .	192
7.20	Spectrogram of a raw signal – left-hand movement – Subject 1 – F4 – quiet environment. . . . .	192
7.21	Spectrogram of a raw signal – left-hand movement – Subject 5 – F4 – quiet environment. . . . .	193
7.22	Spectrogram of a raw signal – left-hand movement – Subject 8 – F4 – noisy environment. . . . .	193
7.23	Spectrogram of a raw signal – left-hand movement – Subject 11 – F4 – noisy environment. . . . .	194
7.24	Spectrogram of a raw signal – right-hand movement – Subject 2 – F3 – quiet environment. . . . .	194
7.25	Spectrogram of a raw signal – right-hand movement – Subject 6 – F3 – quiet environment. . . . .	195

## LIST OF FIGURES

---

7.26 Spectrogram of a raw signal – right-hand movement – Subject 3 – F3 – noisy environment. . . . .	195
7.27 Spectrogram of a raw signal – right-hand movement – Subject 7 – F3 – noisy environment. . . . .	196
7.28 Chebyshev Type I – designed filter. . . . .	196
7.29 Chebyshev Type II – designed filter. . . . .	197
7.30 Spectrogram of a Butterworth-filtered signal – left-hand movement – Subject 1 – F4 – quiet environment. . . . .	197
7.31 Spectrogram of a Butterworth-filtered signal – left-hand movement – Subject 5 – F4 – quiet environment. . . . .	198
7.32 Spectrogram of a Butterworth-filtered signal – left-hand movement – Subject 8 – F4 – noisy environment. . . . .	198
7.33 Spectrogram of a Butterworth-filtered signal – left-hand movement – Subject 11 – F4 – noisy environment. . . . .	199
7.34 Spectrogram of a Butterworth-filtered signal – right-hand movement – Subject 2 – F3 – quiet environment. . . . .	199
7.35 Spectrogram of a Butterworth-filtered signal – right-hand movement – Subject 6 – F3 – quiet environment. . . . .	200
7.36 Spectrogram of a Butterworth-filtered signal – right-hand movement – Subject 3 – F3 – noisy environment. . . . .	201
7.37 Spectrogram of a Butterworth-filtered signal – right-hand movement – Subject 7 – F3 – noisy environment. . . . .	202
7.38 Imaginary left-hand movement – 'F4'-electrode – quiet environment – Butterworth-filtered signals. . . . .	202
7.39 Imaginary left-hand movement – 'F4'-electrode – noisy environment – Butterworth-filtered signals. . . . .	203
7.40 Imaginary right-hand movement – 'F3'-electrode – quiet environment – Butterworth-filtered signals. . . . .	204
7.41 Imaginary right-hand movement – 'F3'-electrode – noisy environment – Butterworth-filtered signals. . . . .	204
8.1 Raspberry PI [122]. . . . .	209
8.2 Raspberry PI – B – scheme [122]. . . . .	209

**LIST OF FIGURES**

---

8.3 Prosthetics with the implementation of TMR [6]. . . . . 210

# List of Tables

3.1	Non-invasive brain imaging methods [73]. . . . .	86
3.2	Characteristics of the EEG brain waves [80]. . . . .	98
3.3	Three Functional States of the Brain [13]. . . . .	100
D.1	Imaginary left-hand movement – F4-electrode – raw signals – quiet environment. . . . .	259
D.2	Imaginary left-hand movement – F4-electrode – raw signals – noisy environment. . . . .	260
D.3	Imaginary right-hand movement – F3-electrode – raw signals – quiet environment. . . . .	260
D.4	Imaginary right-hand movement – F3-electrode – raw signals – noisy environment. . . . .	261
D.5	Imaginary left-hand movement – F4-electrode – filtered signals – quiet environment. . . . .	261
D.6	Imaginary left-hand movement – F4-electrode – filtered signals – noisy environment. . . . .	262
D.7	Imaginary right-hand movement – F3-electrode – filtered signals – quiet environment. . . . .	262
D.8	Imaginary right-hand movement – F3-electrode – filtered signals – noisy environment. . . . .	263

# 1

## Introduction

Nowadays there is a constantly increasing interest in improving control methods not only for people with minor or major motor disabilities, but also for – non-disabled users. One of the research paths, being subject of this dissertation, is connected with bio-signal processing and its implementation for the control purposes. The use of EEG signals – what could be described as 'using thoughts' – has become more and more popular within the last few years as a method for communication between computer, or any other device, and the brain.

As it was mentioned above – Brain-Computer Interface (BCI) is a main theme of this dissertation. BCI belong to a group of specific interfaces as they are able to operate computers (as an example of external environment) with the use of electrical activity of brain. BCI-technology can also be a part of neuroprosthetic technology and its implementation may result in at least partial restoration of some lost biological functions for handicapped users. The possible motor-restoration for handicapped users was one of the reasons of choosing this area for research purposes.

It is also important to mention that BCI is also a system that ables to measure CNS activity converted later into an artificial output, which can replace, restore, enhance, improve or implement natural CNS output. This means that natural output, lost as a result of accident or injury, can be replaced by the implementation of the BCI system.

A brief background to the study and investigation of the effects on using bio-signals – such as EEG – in process of controlling external environments will be

provided in this chapter. The aims and objectives of the conducted research, the used methodology and a very brief summary of what each chapter contains will also be outlined in this chapter.

## 1.1 Background to the Study

This thesis showed the development of thorough investigation into various techniques for using EEG signals for control of computer interfaces. The work also presented some similar solutions and described the differences between the invasive and non-invasive BCIs with emphasis on non-invasive technique. The proposed non-invasive BCI has implemented novel algorithm based on application of the two main analysis components in both time- and frequency-domain.

The proposed solution also enables customisation of the criteria in order to optimise the satisfying results for specific applications. It is also important to notice that only signals with limited information have been processed and that there is no 'full' signal processing.

In this work, the application of an inexpensive, easy to buy (on the open market) headset, which was able to work properly in both real-life and lab environments, was presented. The headset used for the research purposes is the Emotiv EPOC and consists of 16 electrodes. The results have been obtained from five various, anonymous Subjects. The analysed signals have been generated by the brain during experiments involving imaginary movement of hand and leg (both left and right).

This work also presents various filtering and signal processing techniques, which have been tested in order to choose the most optimal solution. The author has also tested various equipment, including one designed and made by herself.

## 1.2 Methodology

The research methodology for this project involved the following activities and approaches:

- Interest in using various bio-signals for the control purposes in order to improve quality of life for the physically handicapped, in their daily tasks. This interest developed during the author's activity in the students' research group – 'nano', which was founded by the user in 2006. This research required experience in signal processing, which was obtained during Master's project, where voice recognition was conducted. That project was based on a small application written in MATLAB and enabled simple control of a toy-car with the implementation of human voice. It also involved design and performance of an electronic control system that enabled the whole control process.
- The next step was to investigate the existing Human-Computer- (or Human-Machine-) and Brain-Computer-Interfaces in both – scientific and popular science literature. It was necessary due to the nature of signals generated by electrical activity of the human brain in order to be able to eventually process and implement them in systems enabling control of various external environments. This project also required the obtaining of some EEG-signals samples from open-source data bases in order to conduct some initial signal processing using MATLAB and basic methods.
- The next step involved the choice of appropriate EEG-device. The author has attempted to design and build simple electroencephalograph, which work was based on novel active electrodes. Initial tests run on this device showed that it was not accurate enough to use if for the research purposes. As a result – an inexpensive electroencephalograph – KT88 was ordered and some initial tests were conducted. The results also showed that the device was inappropriate for the potential BCI-implementation. Some of pre-tests were conducted in another research institution – Silesian University of Technology in Gliwice, Poland. The samples were noised by various internal and external artifacts. The final choice of measurement equipment was – Emotiv EPOC headset.
- Transfer from the Opole University of Technology in Poland enabled the completion of the research and conduct all necessary experiments. Various

filtering techniques were used. Final research outcomes were presented in this dissertation.

### 1.3 Research Questions

The main purpose of this dissertation is to answer the three research questions below, and to evaluate the effectiveness of the chosen research methods:

1. To what extent is it possible to identify the bio-patterns that enable control of an external environment <sup>1</sup>?
2. How effective is the control achieved with the use of bio-patterns acquired from the EEG signals?
3. To what extent can EEG-based control be adapted for use in real-world environments, through the use of various filtering techniques?

### 1.4 Chapters of the Dissertation

This dissertation consists of the following chapters:

#### **Chapter 1 – Introduction**

This chapter described introduction to the research topic and briefly presented the whole thesis.

#### **Chapter 2 – Literature Review**

In this chapter Brain-Computer (BCI) technology was described in detail. It also presented history of BCI including some of existing solutions. Also, the newest trends in this area of science were exhibited in order to enable comparison between the already existing and the proposed method. 'Literature Review' also presented some of Human-Computer Interfaces (HCIs) based on various bio-signals – such as electrooculography (EOG) and electromyography (EMG).

---

<sup>1</sup>Principal evaluation is carried out using a simple embedded application running on the TS-7260 platform. This application is a generic simulation of typical applications in the assisted-living and enabling technologies for the disabled.



### **Chapter 3 – Theoretical Background**

'Theoretical Background' outlined some of physiological aspects of movement and brain-signals generation. As the scientific content of this work relied on detecting the signals generated by specific parts of the human brain – it was pivotal to mention them. This chapter has also provided a detailed introduction to the fundamental components and operation of the human nervous system. Not only physiological aspects of signal and movement generation were presented, but also various bio-signals itself, such as EEG – the main analysed signal – or EMG and EOG.

### **Chapter 4 – Signal Processing – Overview**

This chapter presented various signal processing techniques used for BCI purposes. Some of the signal processing methods have been tested in conducted research in order to find the most suitable solution. The following techniques have been described: Filtering, Wavelet Systems, Transforms, Time-Frequency Signal Processing, Independent Component Analysis (ICA) and other.

### **Chapter 5 – Pilot Study Using Customised Equipment for BCI System**

This chapter presented the process of pilot study with the implementation of customised equipment for BCI system purposes. It also presented in detail application of Morlet Wavelet Transforms and initial tests carried out on data obtained from various open-source data bases.

### **Chapter 6 – Use of Clinical EEG Equipment for BCI System**

In this chapter implementation of two professional, medical devices – KT88-1016 and Neurofax – for the BCI purposes was in detail presented.

### **Chapter 7 – Use of Emotiv Headset for BCI System**

This chapter described in detail implementation of the Emotiv EPOC headset for the potential Brain-Computer Interface use. It also contains both description and implementation of the chosen pattern-recognition method. The implemented applications and the research itself have been thoroughly described.

### **Chapter 8 – Conclusions and Further Work**

This chapter presented contribution of the research and suggestions for the further work.

### **Appendix**

'Appendix' consists of four parts – A, B, C and D. Part A contains the participant information according to Research Ethics Committee regulations, Part B – selected papers in the research area, Part C – Applications' codes in full and Part D – tables with obtained results.

## 2

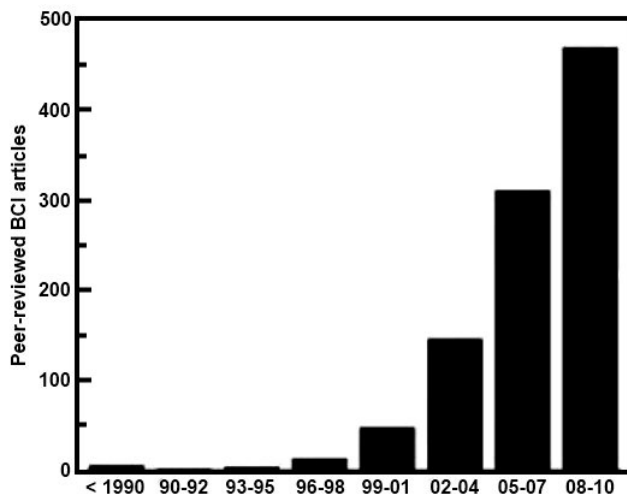
# Literature Review

In this section studies of current and previous work in the author's research area will be presented in detail. This section will present some of the newest solutions that have already been implemented by other researchers in order to show the novel aspects of my research methodology. Not only implementation of electroencephalography (EEG) will be featured, but also the application other bio-signals such as – electromyography (EMG) and electrooculography (EOG). This chapter will also cover various BCI systems, where Emotiv EPOC headset has been implemented.

## 2.1 Brain-Computer Interfaces

Brain-Computer Interfaces (BCIs) have become more and more popular within the past twenty years. Brain-Computer Interface is a type of Human-Computer or Human-Machine Interface, where a human is linked to an external device or environment in order to enable its control and improve usability [1, 2]. Figure 2.1 shows a chart presenting the growth of the peer-reviewed publications in this area [3].

As Brain-Computer Interface Systems are a main theme of this project – short introduction to the topic was necessary. BCIs are, as mentioned above, a particular form of Human-Computer Interfaces, which enable to operate external devices, such as – computers. Electrical activity of the brain is being applied



**Figure 2.1:** The growth of publications regarding BCI [3].

in Brain-Computer Interface Systems as a data source and used for control purposes. BCIs are also a part of neuro-prosthetic technology and may enable partial restoration of some of the lost biological functions of handicapped users [4, 5]. In BCI Systems – brain activity signal, which is caused by subjects’ intentions or thoughts, is being translated and used by appropriate applications – involving signal processing and pattern recognition. Current BCIs use PC computers for both – signal processing and pattern-recognition purposes [6].

Figure 2.2 illustrated five main application types for Brain-Computer Interfaces – ‘replacement’, ‘restoration’, ‘enhancement’, ‘supplementing’ and ‘improvement’. The first application is, when a natural output, lost as a result of e.g. accident or injury, can be replaced by the implementation of the BCI system. The second means, that a BCI implementation is able to restore lost natural output – e.g. implanted, invasive electrodes enable muscles to move limbs. ‘Enhancement’ can be done by performing a task, which requires constant, long-term attention such as driving a car. ‘Supplementing’ can be caused by ‘adding’ additional control, so as a result a person has an additional arm or BCI-controlled joystick together with a traditional, hand-controlled one. ‘Improvement’ function of BCI is related to improving CNS functionality in case the subject can move, but his movement is impaired as a result of e.g. accident. A BCI system is able to stimulate and improve movement [3].

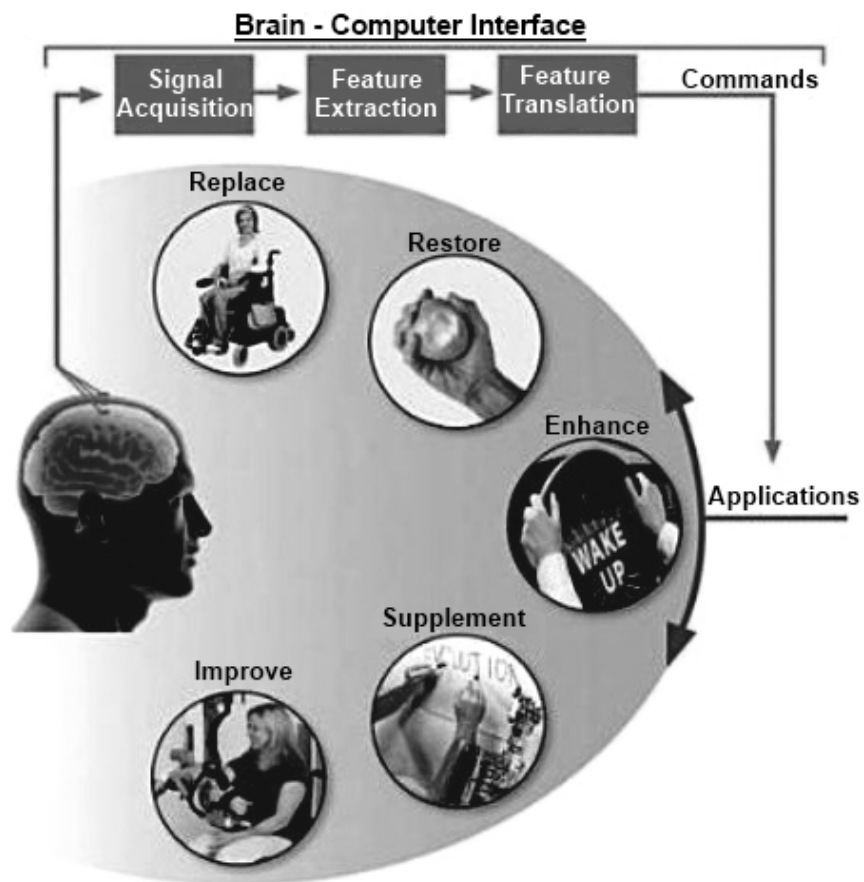
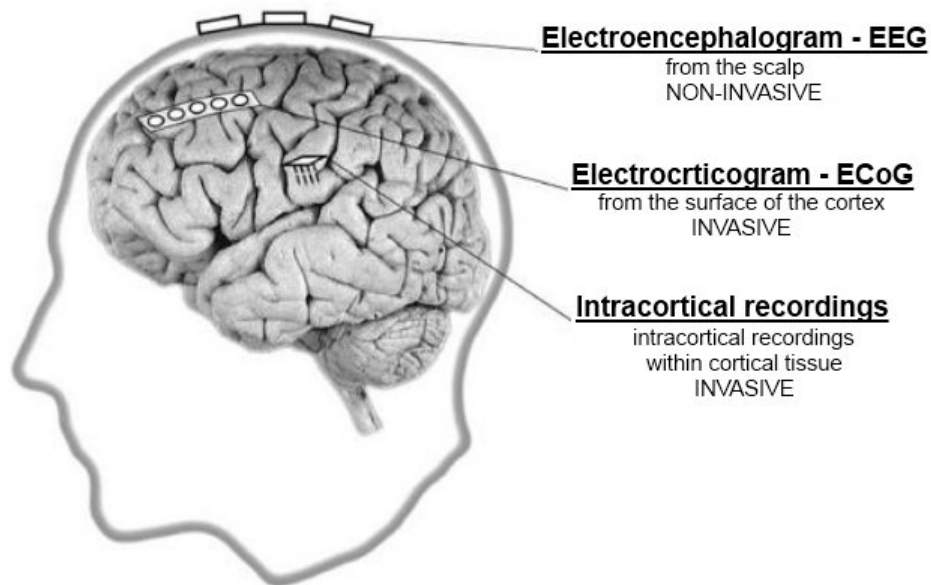


Figure 2.2: Main types of applications controlled by BCI output [3].

## 2.1 Brain-Computer Interfaces

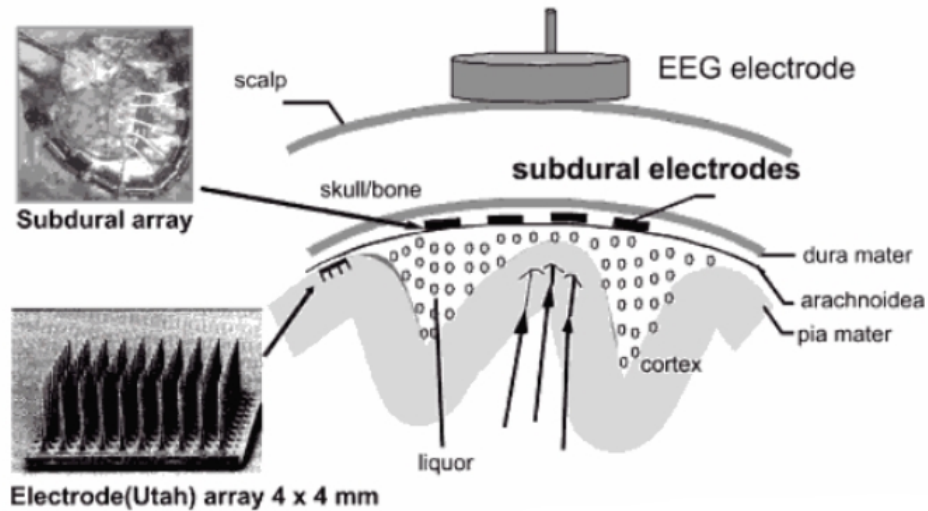
As mentioned above – Brain-Computer Technology can be defined as a branch of science that enables the use of brain signals in order to improve lost motor activity and it is possible to differentiate the two main types – invasive and non-invasive BCI [3, 5, 7, 8].

Invasive methods have one advantage over non-invasive methods – the obtained signal is more accurate and can fulfill needs of wider group of users. The implementation of an invasive BCI is risky, expensive and requires major surgery. Figure 2.3 shows three main types of an brain-recording methods – one non-invasive and two invasive. The non-invasive method is based on Electroencephalography (EEG), where the invasive are – Electrocritogram (ECoG) and method based on Inter-cortical Recordings. One of the ECoG's disadvantages is that it can only be placed for a few days – then it has to be removed, as it may damage tissues [6].



**Figure 2.3:** Three different methods for electrical activity of brain recordings [6].

Brain activity recording methods have also been presented in Fig. 2.4, where both – invasive and non-invasive methods for brain activity recording for the BCI purposes where shown. Also all layers that in the non-invasive systems the signal has to conquer were presented [9].



**Figure 2.4:** Brain activity recording methods [9].

Figure 2.5 presents recording sites for brain signals and as it was mentioned above and illustrated in Fig. 2.3 – EEG signal is recorded from the surface of the scalp, where the ECoG electrodes are placed on the cortical surface, where spikes of an electrodes enable recording data from local-field potentials (LFPs) [3].

The invasive BCI system is based on implantation of an electrode or multiple electrodes into the cortical tissue, what requires serious surgical intrusion [7, 9, 10]. An example was presented in Fig. 2.6 illustrating a simplified block diagram of a neural prosthesis implanted in the invasive way [11].

The biggest aim of the Brain-Computer Interface was to enable people, who lost their natural pathways, through amputation, trauma or any other situation, communication with the world [5, 7, 10]. In the 90's of the 20th century there were attempts to restore the motor function for handicapped people. It seemed possible due to the ability of recording the signals generated during the arm movements [13].

Figure 2.7 shows sample neuro-prostheses, which enable not only to receive an output from the nervous system, but also provide an input. They interact with both peripheral (PNS) and central (CNS) nervous systems. It is also important to mention, that unlike other Human-Control Interaction (HCI) systems – BCI

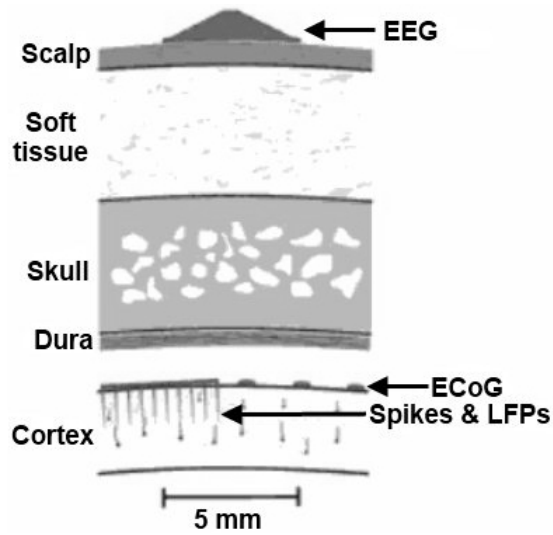


Figure 2.5: Range of electro-physiological measurement methods [3].

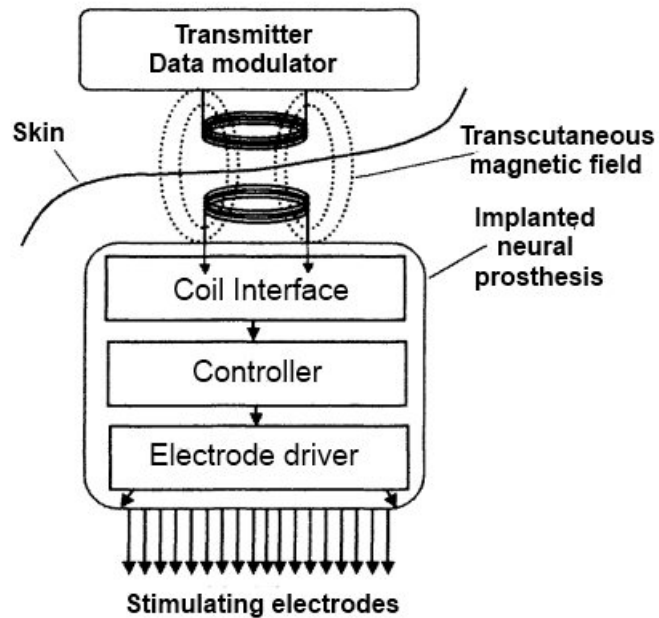
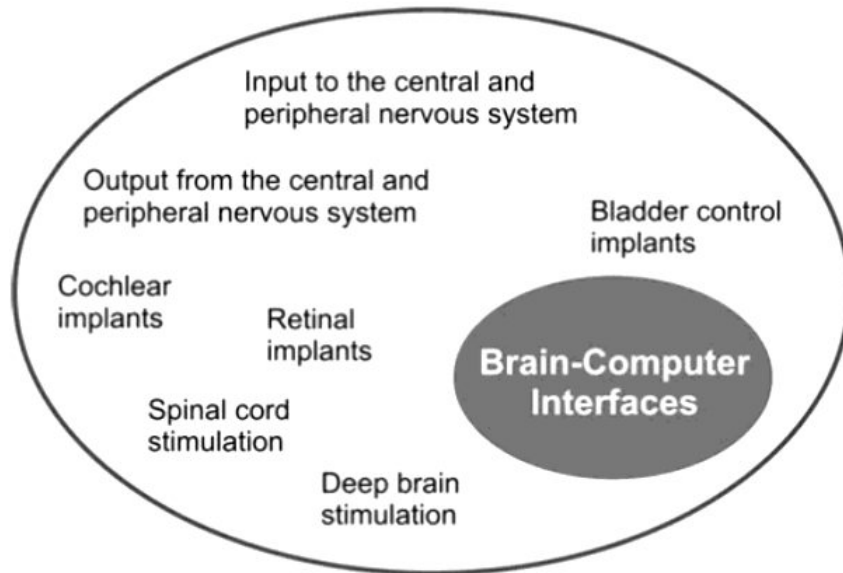


Figure 2.6: Block diagram of a neural prosthesis [11].



provides non-muscular communication with external devices [6].



**Figure 2.7:** Neuro-prosthesis that can be controlled via BCI [6].

Figure 2.8 shows two CNS actions. The left part of the figure illustrates simplified diagram of normal motor activity production. The right part of the scheme presents the same action result, but without muscle involvement, as the same areas are being mediated by BCI. BCI system performs output role of motoneurons [3].

It is important to mention that up to 80 % of patients with limb amputation endure phantom-limb phenomena. This shows that the brain 'disagrees' with the loss of the limb [4]. According to the studies this feature of the brain enables the control of an artificial limb as if it were the original one. A sample net with electrodes implemented in the invasive way to the monkey's brain (as the first tests were run on monkeys) are shown in Figure 2.9 [12].

One of the most important milestones in the BCI-research area was the experiment carried out by the Cyberkinetics company. In 2002 Cyberkinetics were the first, who attempt the implementation of an invasive BCI system in order to restore the motor ability. The first participant was a man with a severed spinal cord. He was a victim of knife attack, which left him paralysed. Cyberkinetics,

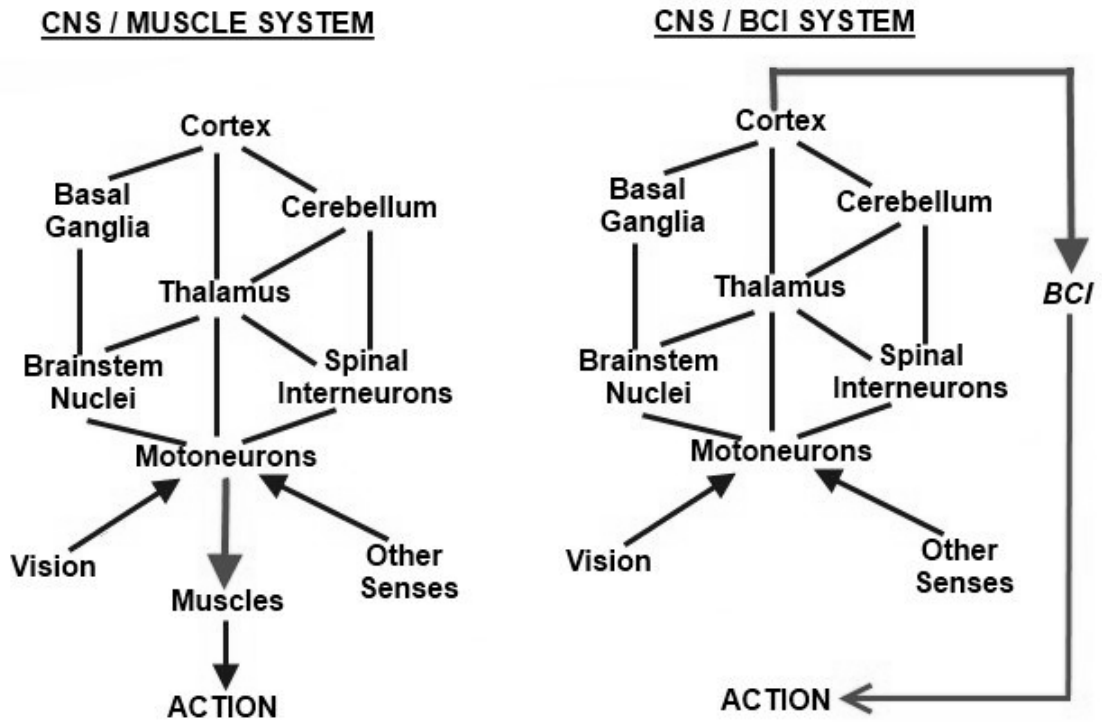


Figure 2.8: Muscle-based and BCI-based CNS actions [3].

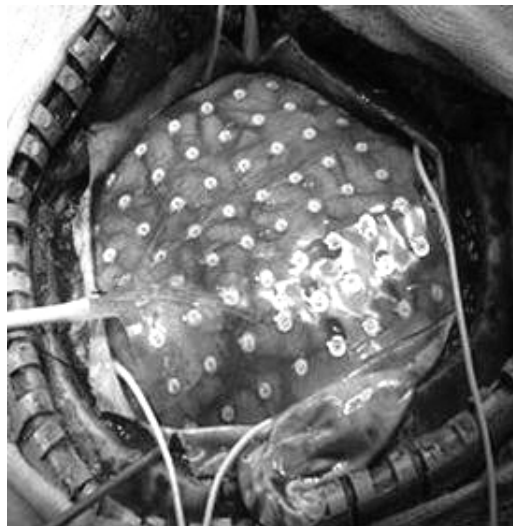


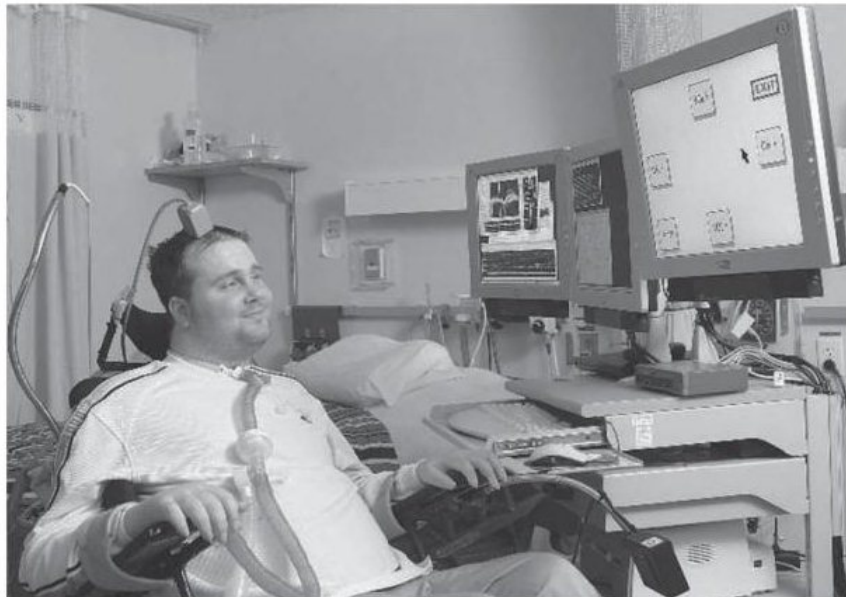
Figure 2.9: Net with electrodes implemented on the surface of a monkey's brain [12].

## 2.1 Brain-Computer Interfaces

---

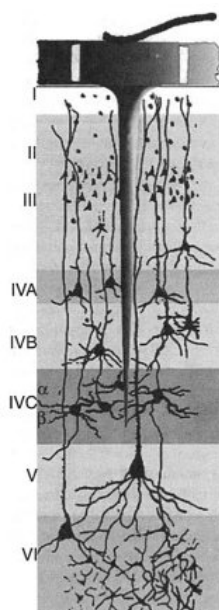
together with John Donoghue and his research team, developed a recording system called Brain-Gate. This system could record signals, which occurred during movement. In June 2004 Dr Gerhard Friehs implanted him the Brain-Gate sensor. The operation took place in the Brown University's Rhode Island Hospital (it took one month for the patient to recover). The researchers observed characteristic changes in the signal gathered from the implant, when the subject thought about moving his right or left hand. These signals were adapted and used for control an artificial limb engaging active cortical neurons. This was a milestone in the Brain-Computer Interface development. The patient was able (after three years – needed for sensation elimination and the training) to do simple tasks using his artificial limb, such as playing Pong and operate TV [13, 14].

The research participant was Matt Nagle (Fig. 2.10), thanks to the discovery of the Cyberkinetiks team he is now able, despite being quadriplegic, to have a more independent life. The chip implanted by Dr Friehs was a size of a baby aspirin. One side of the chip has hundreds of very tiny electrodes pressed to the cortical surface. The research enabled some further patients to do the tasks such as driving a wheelchair or operate a robotic, artificial hand [15].



**Figure 2.10:** Matthew Nagle moving a cursor with his thoughts [14].

Microelectrode designed and implemented by the Cyberkinetics team was presented in Figure 2.11. The electrode had to be implanted as close to the target neurons as possible [11].

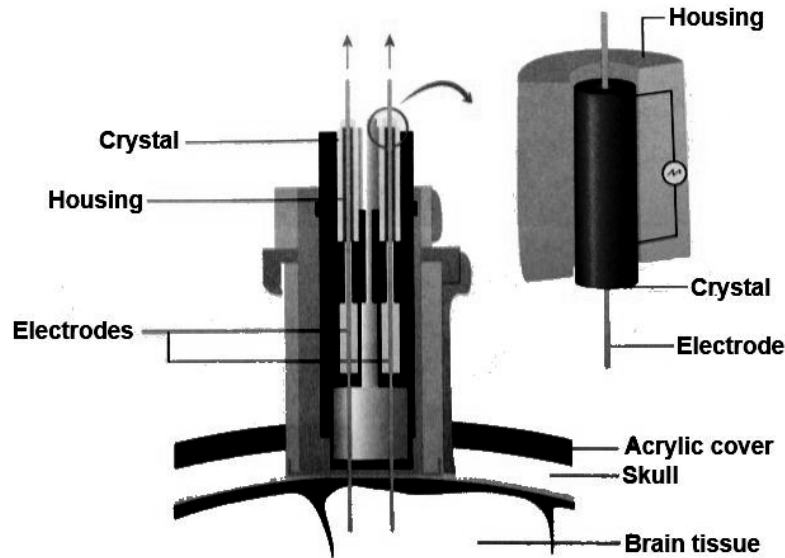


**Figure 2.11:** Microelectrode – Cyberkinetics’ team design [11].

Cyberkinetics were not the only to conduct research on invasive BCI systems. Richard Anderson and Joel Burdick from the Caltech also carried out studies on motor abilities restoration. They noticed that after implantation of an electrode to the brain – in order to restore some of the motor functions – the neurons around the electrodes die after few months following the surgery. Anderson and Burdick found out, that when the neurons die, the electrodes lose the signal. This led to the development of a device, that would enable the slight movement of the electrodes in order to obtain the stronger signal [15].

Presented in Figure 2.12 was the scheme of a moving electrode designed by Caltech. Each implant is located in a crystal of a special type. When the signal gathered from the electrode placement area – a circuit triggers a pulse of electricity to the crystal. As a result electrodes move (very slightly – one micrometer at time) and seek stronger signal sources. After initial and successful

tests conducted on monkeys – the results proved this solution to be satisfactory [12, 15].



**Figure 2.12:** Scheme of a moving implant [15].

Research based on non-invasive methods with the use of EEG started in the 1980s [5]. In the non-invasive BCI system usually apply visual feedback interface, where the alternative for visually impaired subjects is the auditory one [10]. Brain activity can be divided into electrical and magnetic. Figure 2.13 shows EEG-based BCI. This equipment is lightweight, inexpensive and easy to apply, as it does not require any surgical interference. The BCI system consisted of a cap with electrodes, computer system enabling data acquisition and an amplifier [6].

This kind of BCI is based on signals recorded from specific brain areas. The electrodes are placed on the scalp surface according to the 10-20 system – presented in Figure 2.14 [6, 16].

## 2.2 Overview of Existing Solutions

This Section will show a short overview of the most popular existing methods and trends of non-invasive Brain-Computer Interfaces. Invasive technologies are the largest part of the BCI research in North America, where European and

## 2.2 Overview of Existing Solutions

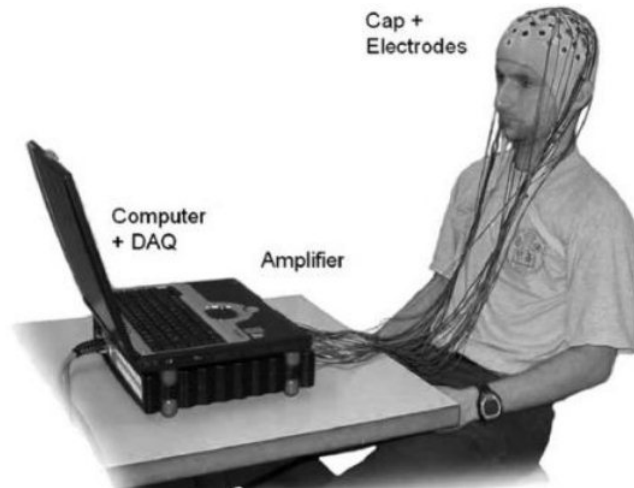


Figure 2.13: Sample EEG-based BCI [6].

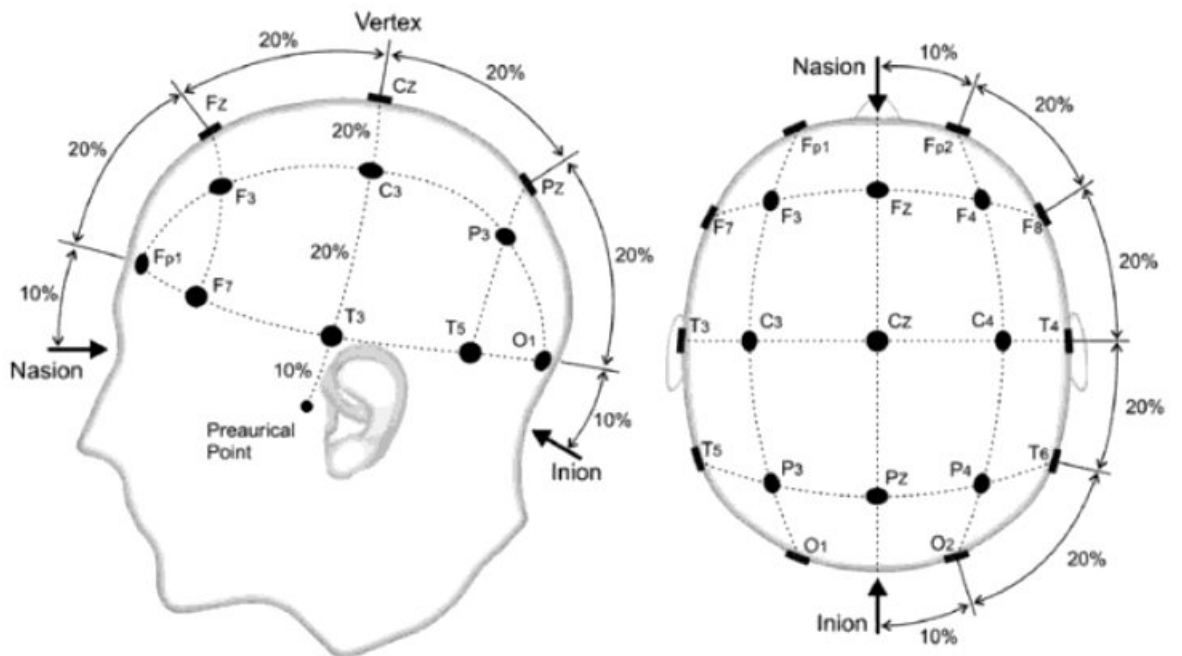


Figure 2.14: 10-20 electrodes placement system – scalp and cross-section [6, 16].

## 2.2 Overview of Existing Solutions

---

Asian researchers concentrate on non-invasive (mostly EEG-based) technologies [7]. One of the trends in the non-invasive BCI research arose at the Wadsworth Center in New York State Department of Health [7, 10]. The main aim of the team from the Wadsworth Center was to develop EEG-based BCI system in order to improve quality of life of severely disabled people by providing them with alternatives in control and communication. This solution used P300-based Event Related Potential (ERP) as a control signal [6, 10]. One of the oldest non-invasive BCIs was designed by the Wadsworth team and the system was based 'Right Justified Box' paradigm, where subjects learned to control using  $\mu$ -waves – as a result of imaginary selection of one of two targets [8].

The P300 BCI is a system based on P300 ERP potentials. Experiments are usually carried out with the implementation of a visual stimulus such as – light flash. It has a wide range of potential application – from controlling a simple cursor to control of a whole mobile robot. Potential P300 occurs around 300 ms after stimulus presentation [6, 8, 16].

The Wadsworth Center BCI uses  $\mu$ - or  $\beta$ -waves for video cursor control, depending on dimension. This is a result of training and is not a normal, natural function of the brain [10].

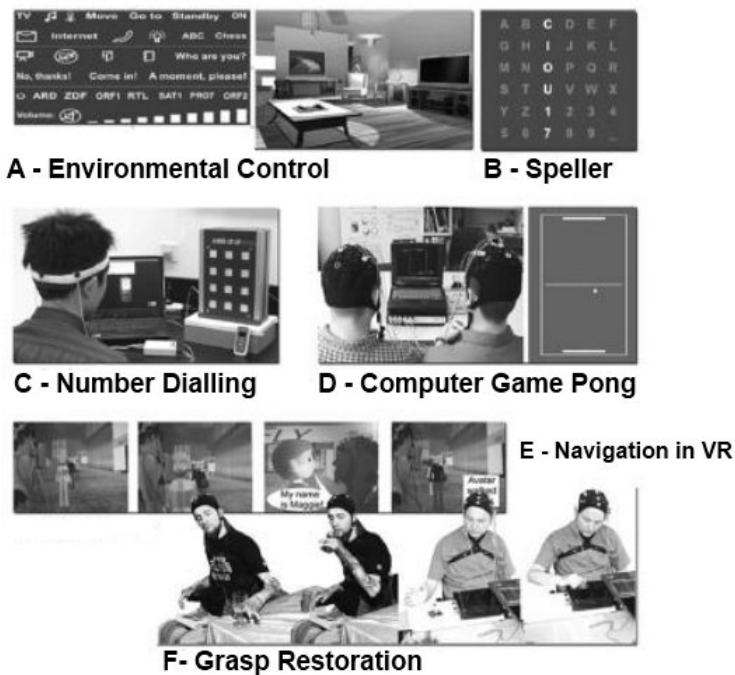
In Europe research team from Eberhard-Karls-University in Tuebingen – Germany together with Fraunhofer Institute FIRST – Berlin, which were( pioneers in the non-invasive EEG-based BCI) had also a large influence on the BCI research. They concentrated on enabling environment communication of paralysed patients with the implementation of non-invasive BCI with the implementation of the three main non-invasive BCI types: 'Slow Cortical Potentials'-BCI (SCP-BCI),  $\mu$ -BCI and P300-BCI. The tests above mentioning paralysed patients showed that all the BCIs were efficient, although P300-BCI and  $\mu$ -BCI worked much faster [8, 10].

Another important 'trend-setter' in the area of BCI technologies is the research group from Graz in Austria. They created their own BCI system called Graz-BCI [7, 10]. This system is based on  $\beta$ - and  $\mu$ -waves. It is also based on Event-Related Desynchronisation (ERD), what is used for the classification of single EEG trials occurring during both – real- and imaginary-motor activities. It is important to mention, that this system works on-line and the analysed signal was gained from the electrodes placed on C3, C4 and Cz positions [10].

## 2.2 Overview of Existing Solutions

It is possible to differentiate a Brain-Computer Interface based on Steady-State Visual Evoked Potential (SSVEP). Typical SSVEP-BCI requires numerous visual stimuli. Each stimulus is related to a specific command [6, 16].

Presented in Figure 2.15 are various BCI applications. Part 'a' of this figure (Fig. 2.15) shows environmental control with the implementation of P300 BCI., part 'b' shows a P300 Speller. The application of phone dialing with the use of BCI is shown in part 'c', where part 'd' shows game 'Pong' for two players. Part 'e' illustrates navigation in Virtual Reality (VR) and 'f' – restoration of grasp functions of paraplegic patients [3, 6, 16].



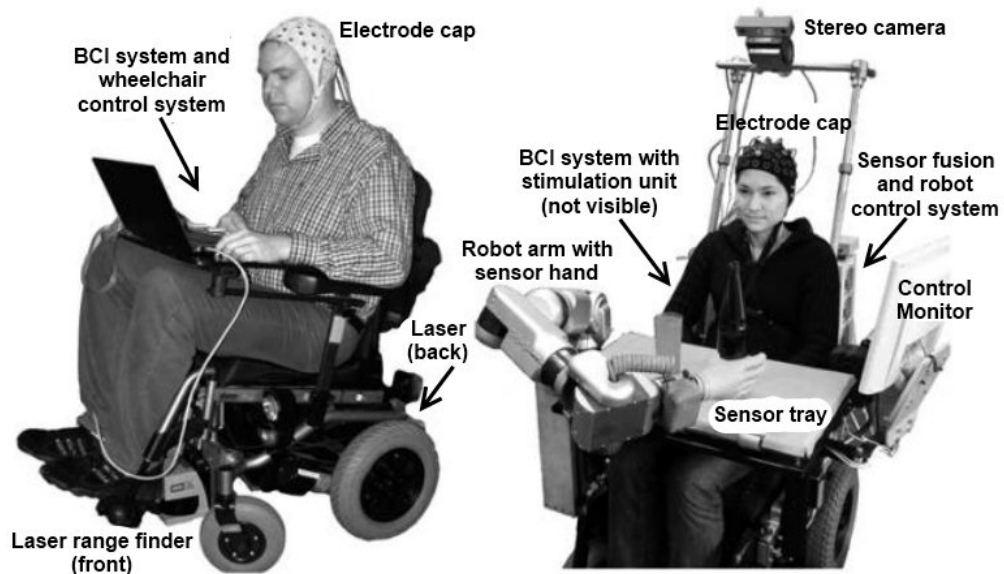
**Figure 2.15:** Various EEG-based BCIs [6].

Figure 2.16 shows two examples of advanced BCI applications developed at the University of Bremen. The first one is called Rolland II and is a semi-autonomous wheelchair, which supports semi-autonomous navigation such as low-level joystick control or high-level discrete control. The second application presented in this figure (Fig. 2.16) is a rehabilitation robot called FRIEND II (Functional Robot Arm with User Friendly Interface for disabled People), which is semi-autonomous system designed for the purpose of disabled people assistance. It helps disabled



## 2.3 The Newest Trends in Brain-Computer Interfaces

patients in activities of daily living. The robot arm has 7 degrees of freedom, gripper with force/torque sensor, smart tray with tactile surface and weight sensors; there is also a computing unit which contains three independent industrial PC computers. A very interesting feature of the FRIEND II system is that it is able to conduct some task autonomously – e.g. ‘pour in beverage’ without spoiling the liquid [6].



**Figure 2.16:** Example of two complex BCI applications – Rolland III and FRIEND II [6].

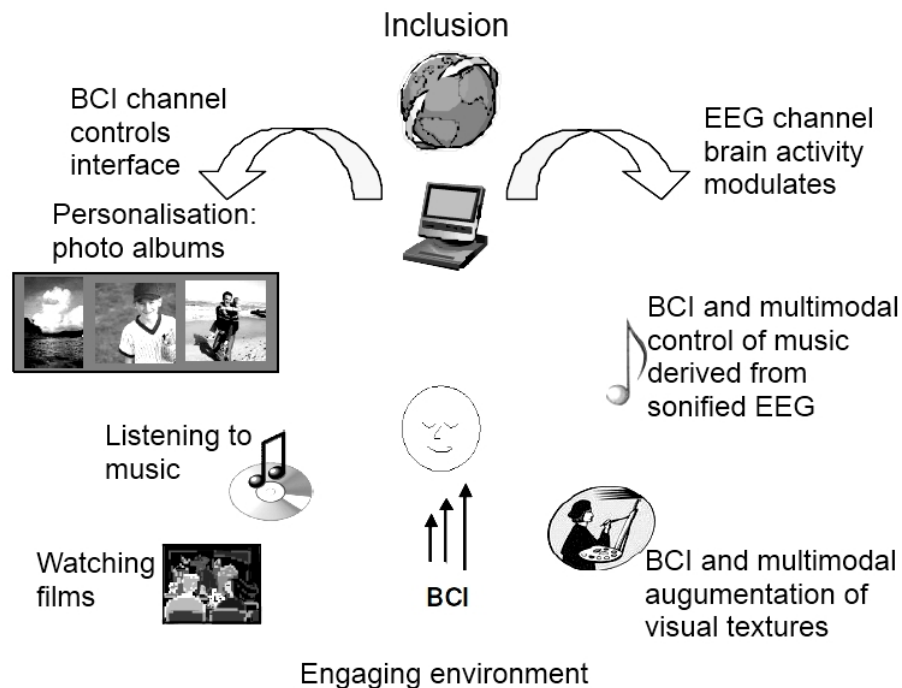
## 2.3 The Newest Trends in Brain-Computer Interfaces

As the area of studies on developing new Brain-Computer Interfaces is constantly increasing and numerous research teams carry out research on improving BCI efficiency, it is impossible to present all current solutions. For the purpose of this study – only some of the newest and most interesting projects have been presented. This section also contains the subsection – ‘Emotiv-based Brain-Computer Interfaces’(2.3.1), where some of the newest implementations of Emotiv EPOC headset have been described in detail.

## 2.3 The Newest Trends in Brain-Computer Interfaces

---

**IGUI-BCI** – IGUI-based Brain-Computer Interface was designed for the purpose of communication with BCI2000 [17, 18]. It was design for severely hand-icapped users with high communication needs. This BCI system is EEG-based and consists of three components – two way interface for BCI2000 communication, interface able to pass commands and device identifiers and – interface to an extensible mark-up language such as XML. In Figure 2.17 possible IGUI-BCI implementation was presented.

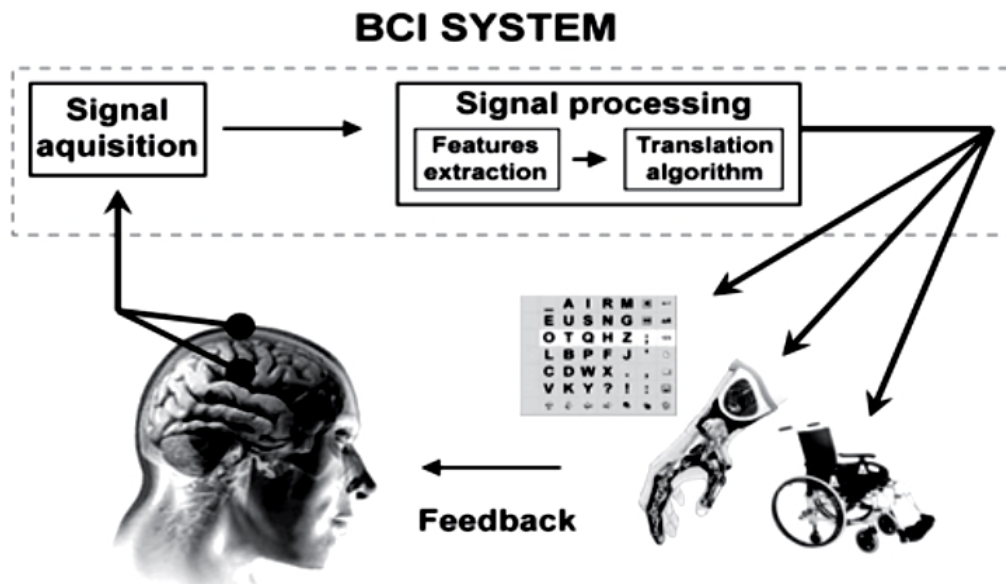


**Figure 2.17:** Possible IGUI-BCI implementation [17].

This intelligent and intuitive user interface provided a graphical menu displaying application content. It was able to co-operate with various BCI systems. It is also applicable to almost all devices, also updating its content. IGUI-BCI enables operating BCI200 or 'OpenBCI' platforms, however it has wider possible implementation [17]. Graphical implementation of BCI Interfaces is more flexible and accessible as it does not require any language translations and is easier to use.

## 2.3 The Newest Trends in Brain-Computer Interfaces

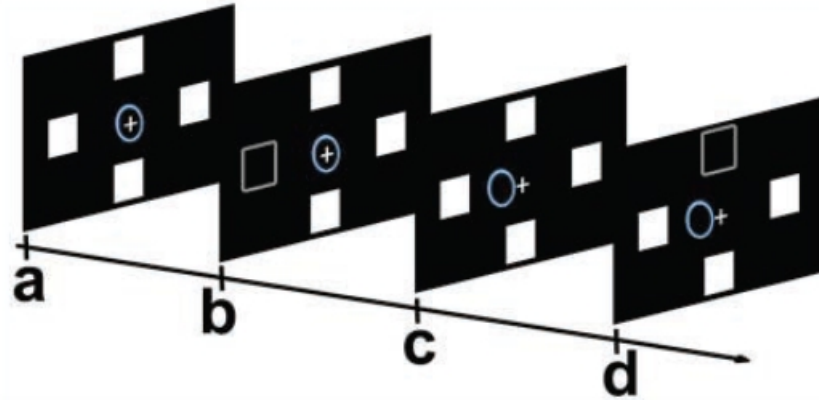
**BCI Systems – Exogeneous vs. Endogeneous** – Exogeneous and Endogeneous interfaces involve implementation of P300-based Brain-Computer Interfaces. It was implemented for the purpose of improving quality of life of patients affected by Amyotrophic Lateral Sclerosis (ALS) and/or Locked-in Syndrome (LIS). This condition remains patients conscious but unable to move muscles and as a result – to communicate. In Figure 2.18 a scheme presenting BCI as communication prosthesis was presented [19].



**Figure 2.18:** Brain-Computer Interface as a communication prosthesis [19, 20].

Two visual interfaces were tested in order to check the performance – Exogeneous and Endogenous. The EEG signal was recorded from four electrodes – Fz, Cz, Pz and Oz. Additionally the EoG signal was also recorded. The interface enables to move a cursor in order to communicate, e.g. placing a cursor on a figure presenting a doctor, would mean 'I need a doctor'. Presented in Figure 2.19 is Exogeneous interface, which orients on attention. The participants of the study had to maintain their gaze on a central fixation point, when the icons randomly disappeared and appeared again after 75 ms. In Figure 2.19 design of exogenous interface implementation was presented.

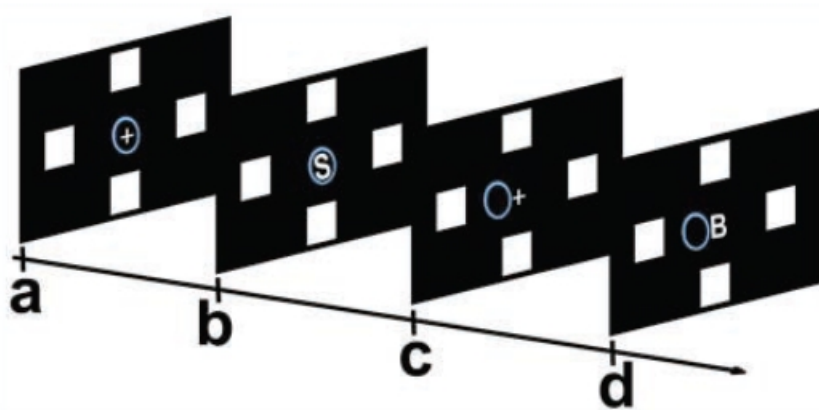
[19]



**Figure 2.19:** Exogenous interface implementation [19].

In Fig. 2.20 – implementation of second type interface – Endogenous was illustrated. In this case the participants of the study had also to maintain their gaze on a central fixation point, however in this case – one of four letters was displayed for 900 ms. The letters were as follows – A (up), D(right), B(down) and S(left). Subjects had to attend the occurrence of letters and indicate the direction of icon placement.

[19]



**Figure 2.20:** Endogenous interface implementation [19].

This study was strongly concentrated on P300-based BCI improvement. It was conducted on impaired users. Two new interfaces were tested. The investigation proved that visual interfaces can be effective and quick – with accuracy of more than 70% [19].

## 2.3 The Newest Trends in Brain-Computer Interfaces

---

**Various P300-based Brain-Computer Interfaces** – P300-based BCI are one of the most popular BCI systems. In these EEG-based Brain-Computer Interfaces the P300 potentials recorded from the scalp may successfully be implemented for the determination of subjects' intents. The ERP P300 is a positive endogenous potential which appears after 300 ms as a result of sound stimulus [19, 20, 25].

One of the most interesting studies conducted on P300-based BCIs involved this potential implementation for environmental control application. A novelty interface, which enable evoking P300 signal was also described. The study was conducted by a team consisting of researchers from Italy and partially funded by the EU grants – FP7-224332 'SM4ALL' and FP7-224631 'TOBI'. The conducted research presented an approach of possible P300 implementation for the control purposes of various remotely operated electric devices such as – TV, lights, telephone, etc. The novelty of this approach means that unlike in other P300-based BCI systems – BCI-control is embedded and does not require using separate screens or windows. In Figure 2.21 user controlling home appliances was presented. The participant wears a cap with electrodes measuring brain potentials – in this case P300 [25]. The potentials are being processed by a computer application – BCI2000. Visual, graphical user interface has been implemented. When the user thinks or concentrates on particular icon – it flashes and P300 potential is being generated, which sends appropriate command to the target device and enables to control it [18, 25].

This interface is based on – as mentioned above – BCI2000 platform and on QualiWorld software [18, 22, 25]. It is also important to mention that no BCI-dedicated window is visible for users and the proposed prototype extended the concept of P300 implementation [25].

Another P300-BCI approach relies on its implementation for social media purposes – such as Flickr or YouTube. Swiss research team from Ecole Polytechnique Fdrale de Lausanne (EPFL). The proposed system presents efficient performance of P300-based BCI with the participation of previously untrained users. This is a novel approach, as P300-BCI usually requires conducting initial tests combined with participants training. In Figure 2.22 a signal acquisition setup was presented [20].

## 2.3 The Newest Trends in Brain-Computer Interfaces

---



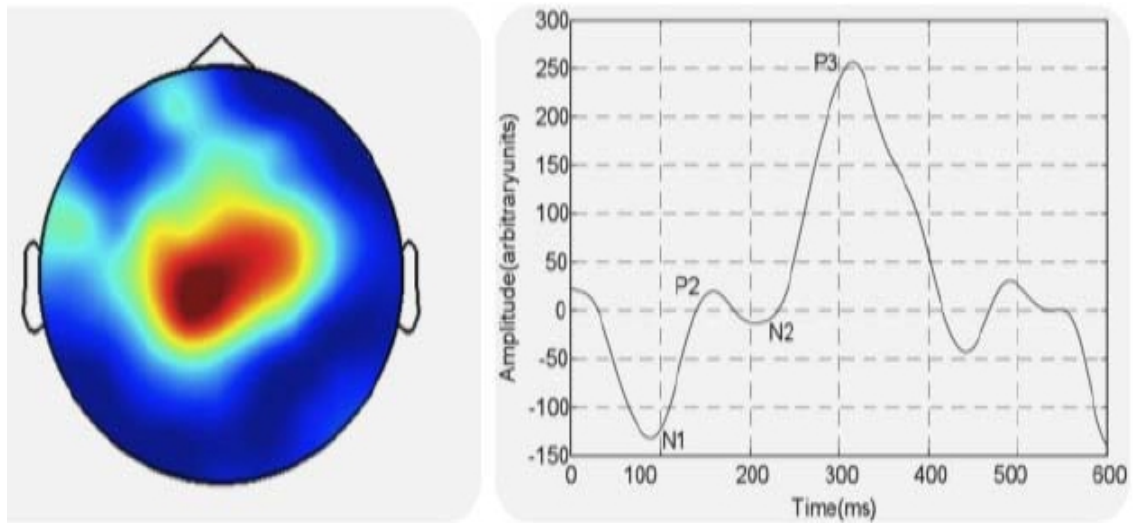
**Figure 2.21:** User controlling home appliances with implementation of P300 BCI [25].



**Figure 2.22:** Signal acquisition setup [20].

## 2.3 The Newest Trends in Brain-Computer Interfaces

The system proposed by the team from Lausanne applies a novel approach in stimulus-driven BCI system based on ERP – P300. It was initially designed for environment control purposes. P300 patterns were presented in Fig. 2.23 and the BCI's GUI – in Fig. 2.24 [20].



**Figure 2.23:** Spatial (left) and temporal (right) patterns of P300 component [20].

The data was gained from thirty two electrodes. Filtering was conducted with a zero-phase, 6th order, bandpass Butterworth filter. The cut-off frequencies were 1-12 Hz. Filtering was carried out in MATLAB, where double filtering – 'filtfilt' – was used. Sampling frequency of the original data was 2048 Hz, which was reduced to 32 Hz. Low-pass Chebyshev Type I filter with a cut-off range 12.8 Hz was also implemented. The signals were noisy and some internal artifacts were present, such as – eye blinks or eye movements. They had to be removed in order not to be mistaken for P300 potential peaks [20].

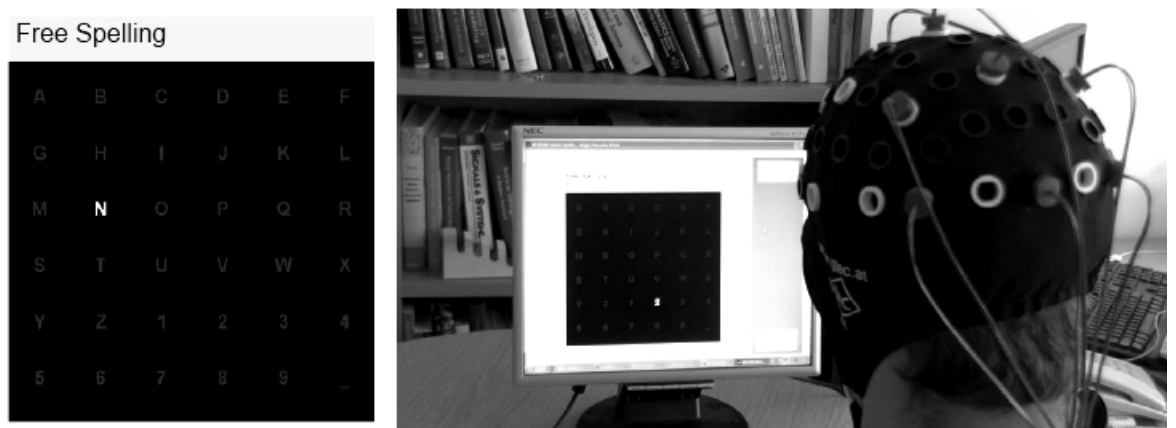
An interested approach was presented by the team from the University College London (UCL). The proposed system integrated BCI with a multi-touch surface. It is also based on P300-potential. Unlike other P300-BCIs – this one instead of implementing alphabet as a visual target, applies multi-touch screen with selected targets. This solution enables to customise user-assembled collection of targets or objects [23].

## 2.3 The Newest Trends in Brain-Computer Interfaces

---



**Figure 2.24:** Graphical User Interface of the P300-based BCI [20].



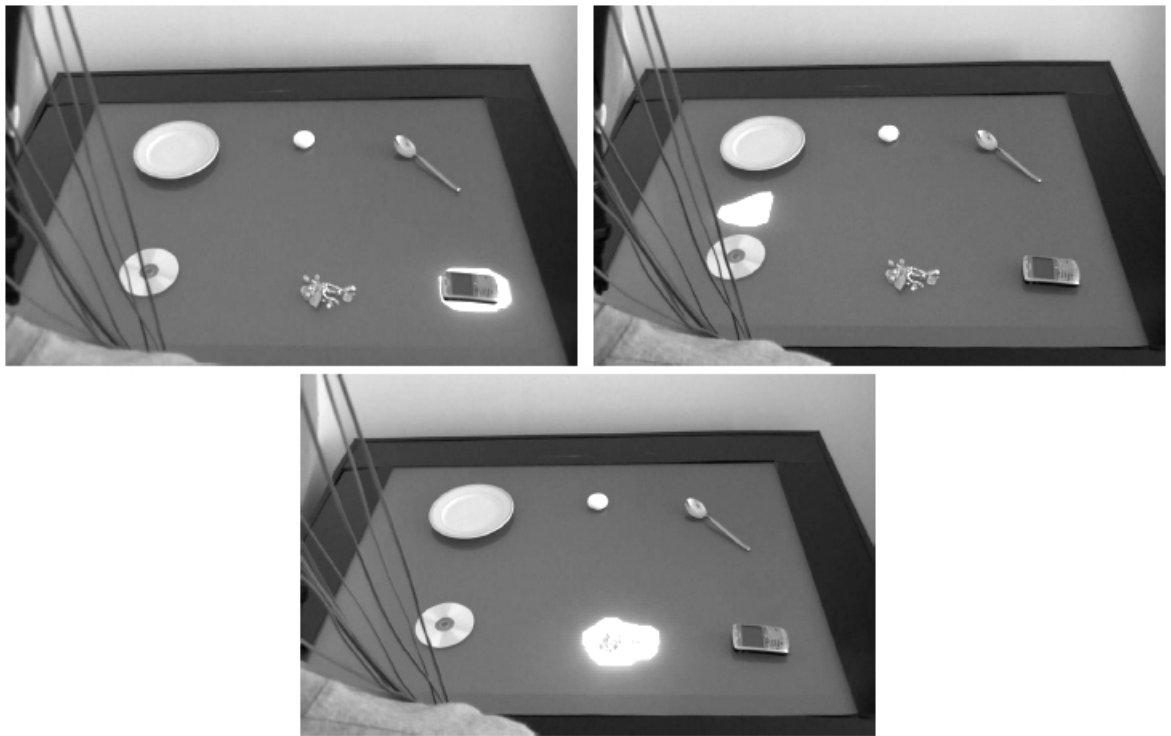
**Figure 2.25:** Interface of a 'Free P300-speller' designed by Guger Technologies [24].



## 2.3 The Newest Trends in Brain-Computer Interfaces

In Figure 2.25 an interface of the P300-speller from Guger Technologies was presented. Each flash lasts for 60 ms, dark time interval is 10 ms. For the experiment purposes 'g.MOBilab +' EEG was used. The EEG system contains only 8 electrodes – Fz, Cz, P3, Pz, P4, PO7, Oz and PO8. It is wireless and portable [23, 24].

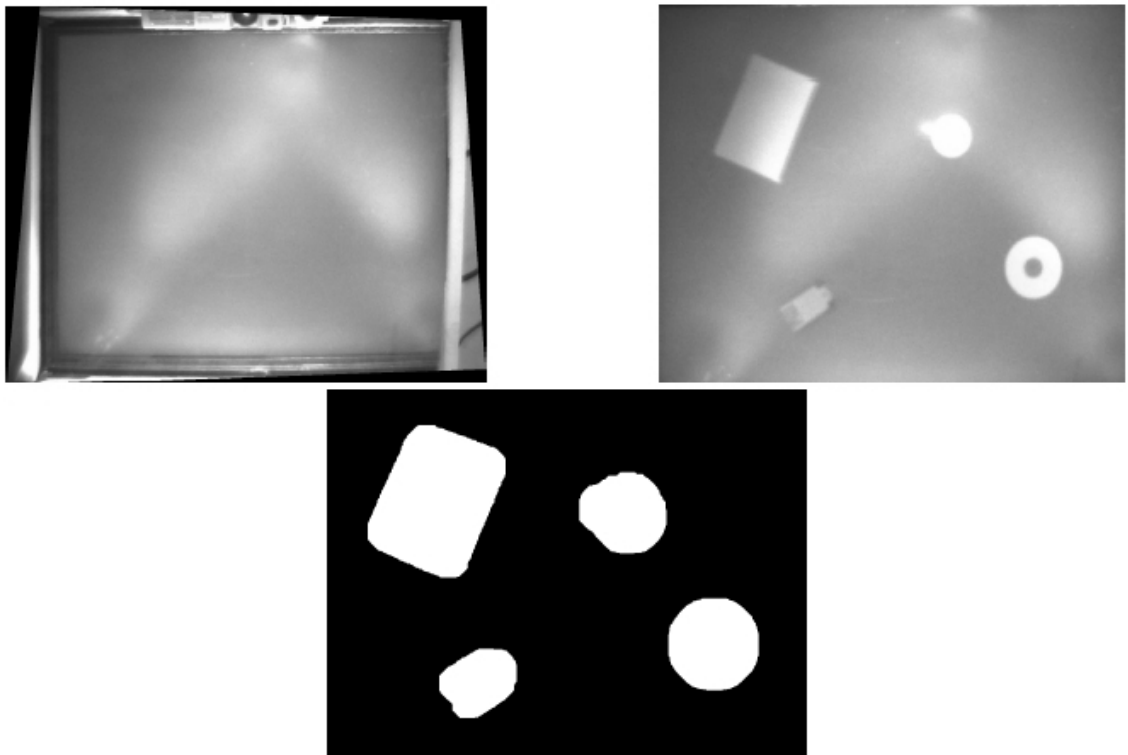
Presented in Figure 2.26 is the interaction with the multi-touch P300-BCI. Six different objects have been placed. Figure 2.27 illustrates an image-processing pipeline applied for that project [23].



**Figure 2.26:** A participant interacting with the multi-touch P300-based BCI [23].

Research project proposed by UCL-Team presented new opportunities for HCI. It widens communication process for 'locked-in' users through allowing an interaction with real objects. This may be more intuitive and convenient than applying traditional, based on spelling, methods [23].

**BCI for Video Games** – Research on possible applicability of BCI for 3D Video Games proved that despite limitations of majority of Brain-Computer In-



**Figure 2.27:** Image-processing pipeline – raw background image from camera showing the underside of the table (top-left), cropped and rectified image with four objects (top-right), after background removal, thresholding and filtering, four connected components (blobs) are detected and labeled (bottom) [23].

## 2.3 The Newest Trends in Brain-Computer Interfaces

---

terfaces – it can still be an interesting alternative to traditional devices such as a keyboard, mouse or pad. The concept proposed by Fabien Lotte has only been tested in laboratory-controlled environment, although there is a possibility for a real-life application. Figure 2.19 presented BCI-based navigation. Fabien Lotte discussed all limitations and disadvantages of applying BCI technologies for 3D games, such as high recognition error rate, but he proposed implementing BCIs as additional control channel [26].

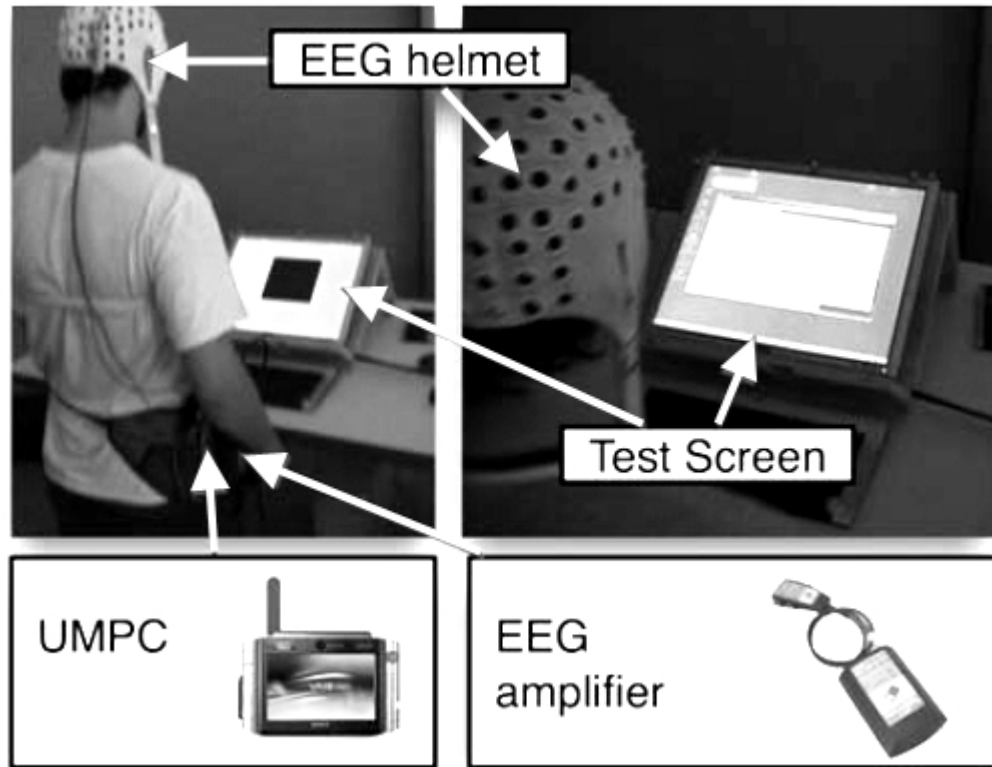


**Figure 2.28:** BCI-based navigation in complex Virtual Environment (VE) [26].

**Graz Brain-Computer Interface** – Graz researchers are one of forerunners in the area of non-invasive BCI technologies. One of their newest approaches is to design a mobile, wearable system. The proposed BCI is EEG-based. The system is aimed for secure computer terminal login and based on detection of characteristic brain patterns. The patterns were evoked by looking at a blinking screen of the computer terminal. The system was designed and was tested in real-life conditions. The result of the study presents a product that may be in a future used for biometric identification. In this solution mobile scanner is replaced by human perception[27].

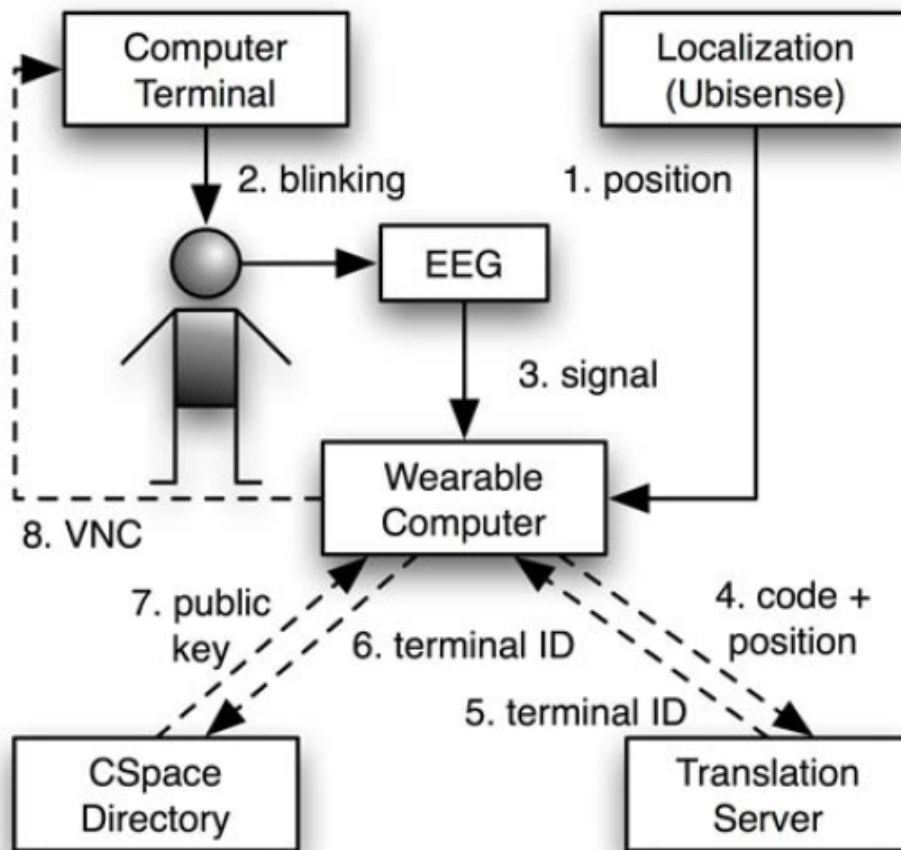
## 2.3 The Newest Trends in Brain-Computer Interfaces

For study purposes a user is equipped with a portable computer – Sony Vaio UX280p and a portable EEG – g.tec mobilab2 [24, 27]. Figure 2.29 presents the proposed wearable BCI solution [27].



**Figure 2.29:** Wearable BCI setup [27].

The overall VNC secure connection establishing procedure has been presented in Figure 2.30. The position is being determined by localisation service, then – characteristic screen blinking is being observed by a user, the code is detected from the EEG. Next step – code and position are transmitted to the translation server, where ID is returned to the terminal. ID is being then sent to CSpace directory. It is important to mention, that the proposed system allows users to create unique, not easily forgotten signatures, which allow efficient two-way human-environment communication. The Graz team is currently working on implementation of laser-based BCI, which (as initial tests proved) is quicker and more effective than a traditional EEG-based one [27].



**Figure 2.30:** Work-flow for establishing a secure VNC connection to a computer terminal after the terminal has been identified using BCI [27].

## 2.3 The Newest Trends in Brain-Computer Interfaces

---

**EEG-based BCI Driving Simulator** – A project for implementing a BCI technology in driving simulator will be presented here shortly. The study investigated ERD/ERS during both – real and imaginary hand movements. The proposed driving simulator was based on ERD speed control. The EEG signal was measured from C3 (left parietal) and C4 (right parietal) electrodes. The referencing electrodes were placed on Fcz and Fpz positions. Sampling frequency was very high – 500 Hz. The used cap was ActiCAP and amplifier – Biotop6R12. The averaged power of signal gathered from the C3 and C4 electrodes was 10-12 Hz. The test have proved that the speed of a car could be controlled with ERD, however the accuracy and controllability were limited due to the latency and nature of EEG signals, which are usually noisy and contain various artifacts [28].

### 2.3.1 Emotiv-based Brain-Computer Interfaces

Implementation of inexpensive, open-market device – Emotiv EPOC – for the BCI purposes was one of the main tasks of this project. Therefore a thorough literature review has been performed. In this subsection some of the Emotiv EPOC headset applications have been shortly presented.

It is also important to mention, that Emotiv EPOC headset has three types of control – EEG-, EMG- and Gyroscope-based [29].

**Implementation of Emotiv for the 3D Video Game control** – Emotiv EPOC headset implementation for the gaming purposes has been a theme of the project described in this paragraph. In this case user’s emotions (meditation, excitement, engagement) as an input source have been applied. The project uses Emotiv EPOC for gathering brain waves, which may indicate levels of excitement. Emotiv headset measures voltage fluctuations, which result from ionic current flows within the neurons of the brain [30]. As the headset has not been designed for clinical use – it may have some errors while registering brain signals, however it can successfully be implemented as a game controller, as it was designed for this purpose [30, 31].

## 2.3 The Newest Trends in Brain-Computer Interfaces

---

**Project on Testing Emotiv EPOC Headset Capabilities** – Project presented in this paragraph describes investigation on potential usage of affordable Emotiv EPOC headset. The device has three types of controls: EEG (electroencephalograph) measured electrical activity in the brain, EMG (electromyograph) measured electrical activity in facial muscles, and a Gyroscope (controlled by head/neck movements). The study has proved that possible EEG component of Emotiv could be more efficient while used with other User Interfaces, but would require additional training for potential users with limited motor control. In Figure 2.31 a participant with Emotiv EPOC headset was presented [29].



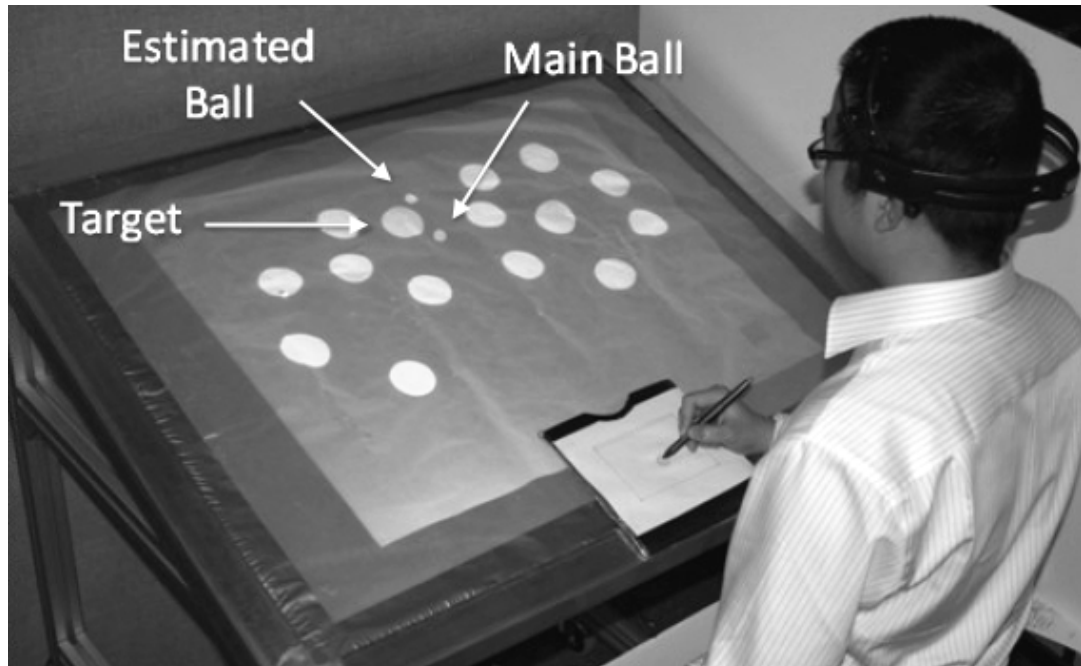
**Figure 2.31:** Participant using Emotiv [29].

**Error-Related Negativity Detection with the Implementation of Emotiv EPOC Headset** – In this paragraph the possible implementation of Emotiv in order to detect brain potentials called Error-Related Negativity (ERN) was shortly presented. The study is pioneer in the demonstration of possible ERN detection using inexpensive BCI headset. The experiments were carried out during Flanker task – multiple choice reaction time (RT) and was conducted in similar to office – with ambient noise – conditions. This study also compared Emotiv

## 2.3 The Newest Trends in Brain-Computer Interfaces

---

EPOC headset with another inexpensive, easily available device – NeuroskyTM [32]. As it was mentioned above – Emotiv has not been designed for clinical use and therefore the accuracy of gained signal may not be high [31, 32, 33, 34]. These have made clear ERN detection difficult. ERN appear during RT tasks – mostly during Flanker one – a visual experiment where a response to a central and directed symbol (surrounded by other – distracting – symbols) is required. Most ERN-Detection based experiments are carried out with the implementation of expensive systems, such as – NeuroScan, BiosemiTM or those provided by the Gruger Technologies [24, 32]. Figure 2.32 shows user performing Superflick task [32].



**Figure 2.32:** A user wearing Emotiv EPOC during Superflick task performance [32].

**Emotiv-based NeuroPhone** – Handless, quick and effortless human-mobile interaction was presented in this paragraph. Proposed project of NeuroPhone makes use of the currently most popular mobile phone – iPhone and inexpensive EEG-headset Emotiv EPOC (shown in Fig. 2.33). Demonstrated interface, based



## 2.3 The Newest Trends in Brain-Computer Interfaces

on P300-Speller – where a sequence of photos is being flashed, was presented in Figure 2.34 [34].



Figure 2.33: NeuroPhone system [34].

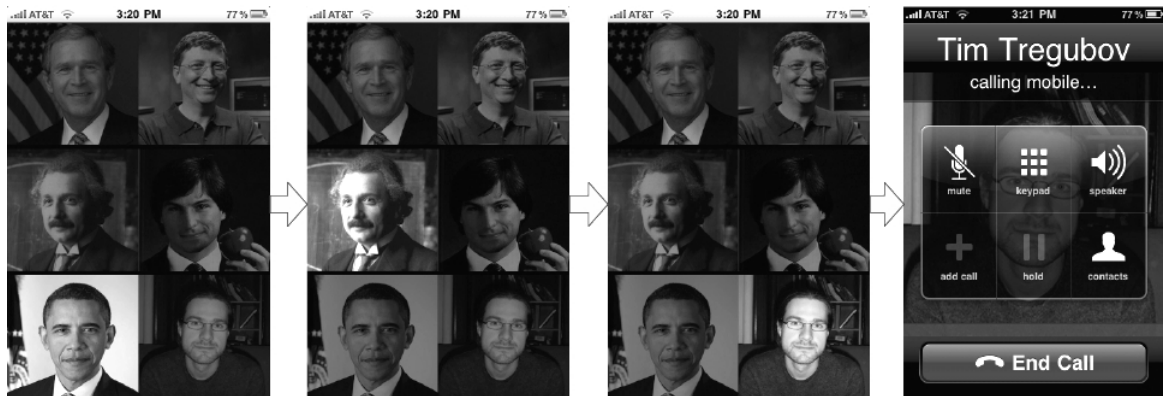


Figure 2.34: P300-based Graphical User Interface of NeuroPhone [34].

Signal to Noise Ratio (SNR) is very low, as Emotiv headset is not intended for clinical use or finer signal detection [31, 34]. The authors of the study applied both – Independent Component Analysis (ICA) and band-pass filtration in order to increase SNR. There has been more similar to NeuroPhone projects done, however

these implemented professional, research-quality equipment, where novelty of this study relies on inexpensive EEG headset application [34].

## 2.4 Various Human-Computer Interfaces

Human-Computer Interfaces (HCI) enable direct communication between computer and users without any additional devices such as mouse or keyboard. They usually apply various signals generated by human body as a source data. In communication between humans – only a small amount of information is being exchanged and this process is carried out through spoken language (direct communication), where the rest is given by indirect communication, such as – body language or facial expression. Indirect communication is implemented in HCI systems [35].

Human-Computer Interaction does not always implement only brain-signals. In these sections other HCI systems – EMG- and EOG-based – will be shortly presented.

### 2.4.1 Electromyography-based Human-Computer Interfaces

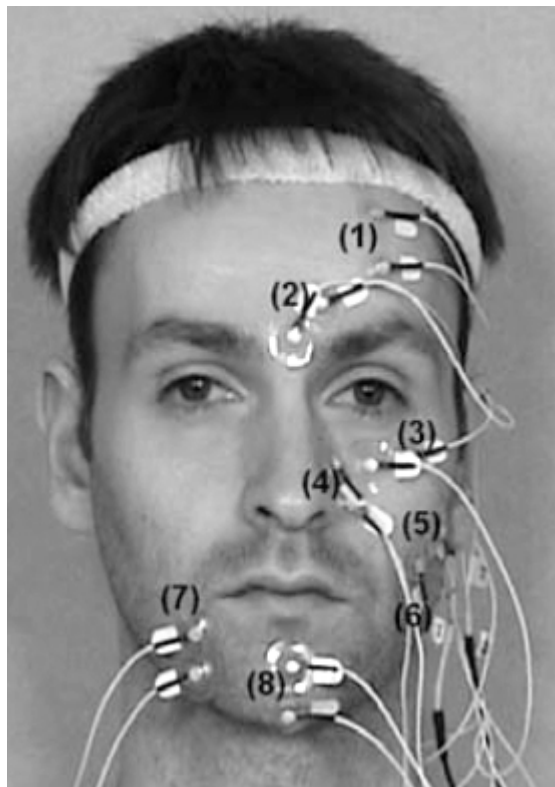
Electromyography (EMG) is a technology, where electrical activity of skeletal muscles is being evaluated. Despite the fact, that this technology has not been applied for this study purposes, it is important to mention its possible HCI-implementation.

**Facial EMG-based Video Recognition System** – This project presented implementation of facial EMG sensors in order to improve Human-Computer Interaction system. The reason for this is to recognise mood of the potential user (indirect communication implementation). The proposed technique presents efficient facial video recognition system. The system consists of 8 EMG sensors – presented in Figure 2.35. The obtained signal was filtered with a Butterworth low-pass filter (sixth order, 10 Hz). The electrodes were placed according to the below system:

## 2.4 Various Human-Computer Interfaces

---

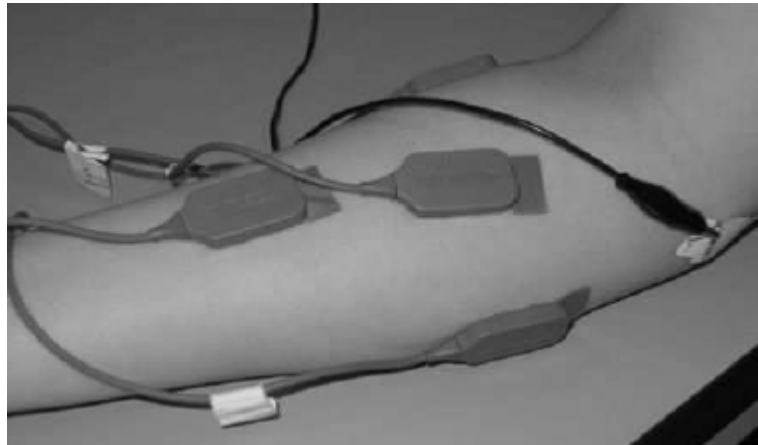
1. Venter frontalis pulls the eyebrow up;
2. Corrugator supercilii pulls the eyebrow to the medial corner and down;
3. Orbicularis oculi constricts skin around the eye;
4. Levator labii wrinkles the nose, stretches nasal wings and rises upper lip;
5. Zygomaticus major pulls mouth corners upwards and laterally;
6. Masseter raises jaw and presses teeth together;
7. Depressor anguli oris controls shape and size of mouth opening;
8. Mentalis pushes skin above chin upwards and curves lips upwards.



**Figure 2.35:** EMG sensors placement [35].

Mean recognition rate of facial expressions was 92% [35].

**EMG-based Hand Gestures Identification System** – This paragraph presents a study on EMG-based hand gestures identification system. The muscle activity separation was conducted with the implementation of Independent Component Analysis (ICA). This project, unlike other similar, was designed for gross actions or actions, where one prime-mover muscle is being involved. In Figure 2.36 is presented. The study proved that the efficiency of the proposed method was 100 % and the advantage of this system is that it can be easily implemented in real-time after some initial training [36].



**Figure 2.36:** EMG electrodes placement [36].

**EMG-based Sign Language Recognition System** – Sign Language Recognition (SLR) enabled communication between deaf and hearing people. The SLR technique provides a good basis for gesture-based HCI system. This paragraph describes in short project, where inexpensive, hand-made, portable EMG sensors. The portable EMG sensors and accelerometers – worn on a forearm were presented in Figure 2.37. The system is based on 121 Chinese most commonly used sign sub-words. The applied EMG consisted of 4 channels. The average recognition efficiency was 95.78% [37].

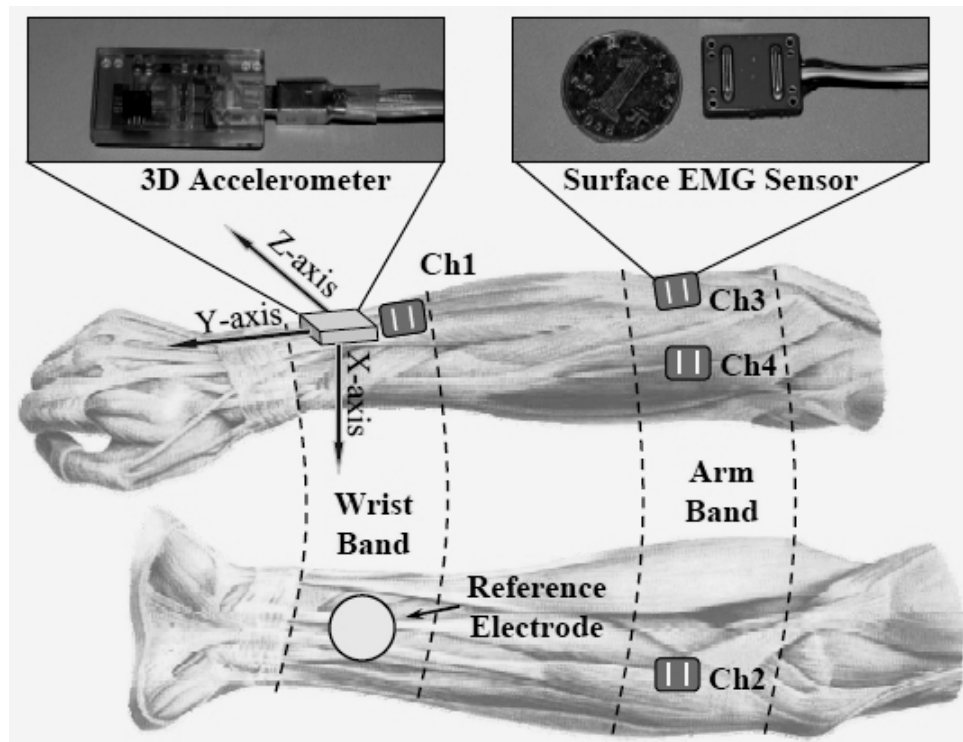


Figure 2.37: Portable accelerometers and EMG sensors [37].

### 2.4.2 Electrooculography-based Human-Computer Interfaces

Electrooculography measures resting potential of retina. It is mainly applied for eye movement recording. EOG does not respond to individual visual stimuli. Application of EOG in HCI systems is popular and therefore was shortly presented in this subsection.

**Wearable Electrooculography** – This paragraph presents novel implementation of eye tracker for context-awareness and mobile HCI applications. The proposed system consists of goggles with dry electrodes. The device is small and portable and its work is based on real-time EOG signal processing. It is able to store data and stream it over Bluetooth. The proposed device also enables effective eye gestures recognition. In Figure 7.38 EOG-based eye tracker pocket system was presented, where armband with cloth bag was marked with number 1, the Pocket – 2, the Goggles – 3 and dry electrodes – 4. The goggles work by a person in horizontal position – h, vertical – v, light sensor – l and accelerometer – a. To the major advantages of EOG-signal processing belongs the fact that minimal power and computation is required [38].

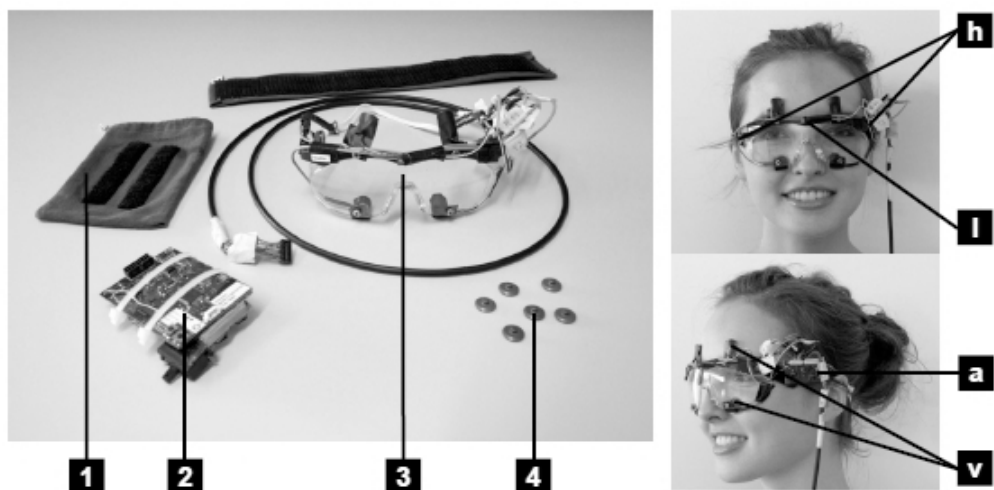


Figure 2.38: EOG-based eye tracker with its components [38].

## 2.5 Summary of the Literature Review

**Vision-based Commodity Eye-Tracking Mechanism** – The main idea of the project presented in this paragraph is to demonstrate a system that would predict the time individual users spend on reading single words. The study resulted in algorithms implemented in the Microsoft Word, which improved user-oriented document in better agreement with potential users' expectations and preferences. In Figure 2.39 customised document browser was presented. Each red circle represented user fixation point. The circles are visible only during debugging process and do not appear while the application is being used [39].

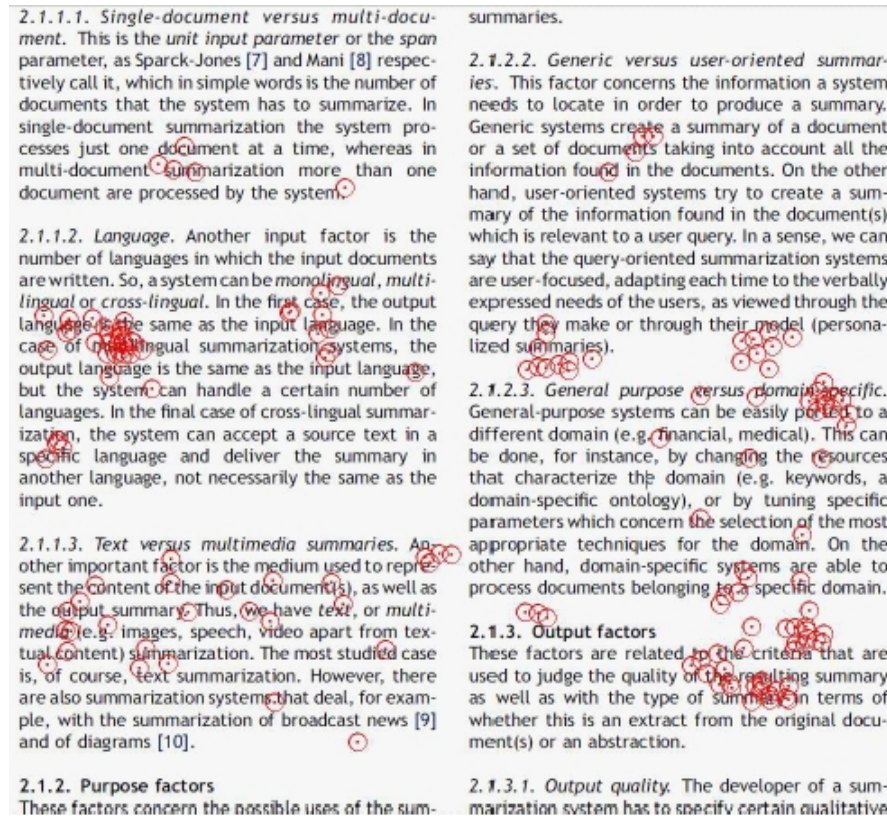


Figure 2.39: Snapshot of custom document browser [39].

## 2.5 Summary of the Literature Review

To sum this Chapter up – the research on BCI technologies has been conducted for over twenty years and its results enabled improving communication and con-

## 2.5 Summary of the Literature Review

---

trol technologies for people with severe disorders. Also some healthy or people with minor disabilities can benefit from it. Figure 2.40 presented comprehensive overview of Brain-Computer Interface components together with their relation with each other [6].

Brain-Computer Interface is able to produce two sorts of commands outputs, which apply to movement of wheelchair – goal selection and process control. Figure 2.41 presented goal selection. Goal in this case is user’s intention, so the BCI communicates this goal to the software implemented in the application. This application enables intention processing, such as moving the wheelchair towards location facing the television. Figure 2.42 illustrated control process in the BCI. Both user and BCI are able to control all details and aspects of this process in order to accomplish user’s intention. BCI together with user generated sequence of commands, which are converted into actions by wheelchair [3, 8].

Since the Berger’s discovery of EEG in 1924 – a lot has changed in the world. The BCI technologies are nowadays very trendy and hundreds (if not thousands) research teams work on improving already existing methods or on developing completely new systems. Only some of them have been mentioned in this Chapter.



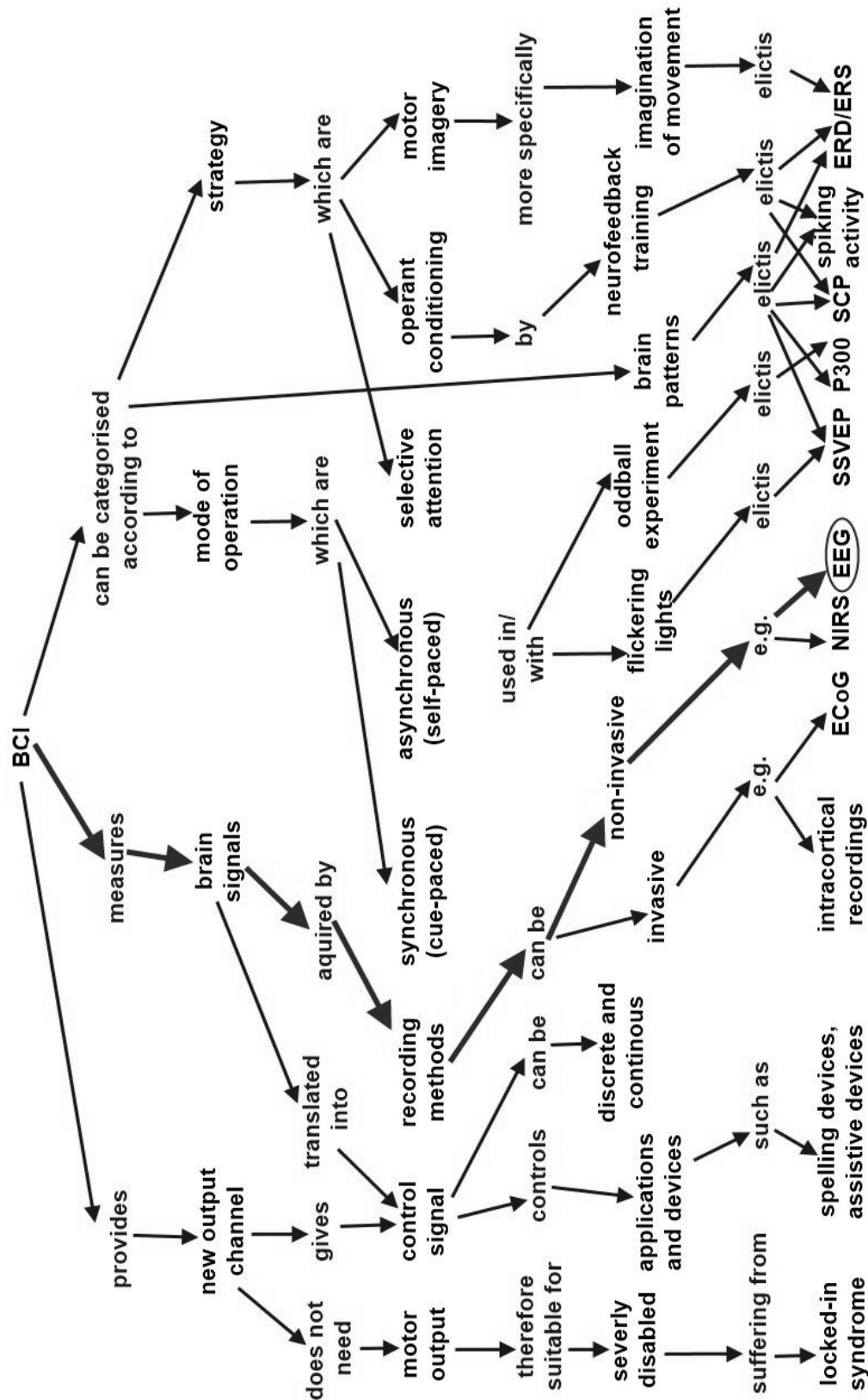


Figure 2.40: BCI concept map [6].

## 2.5 Summary of the Literature Review

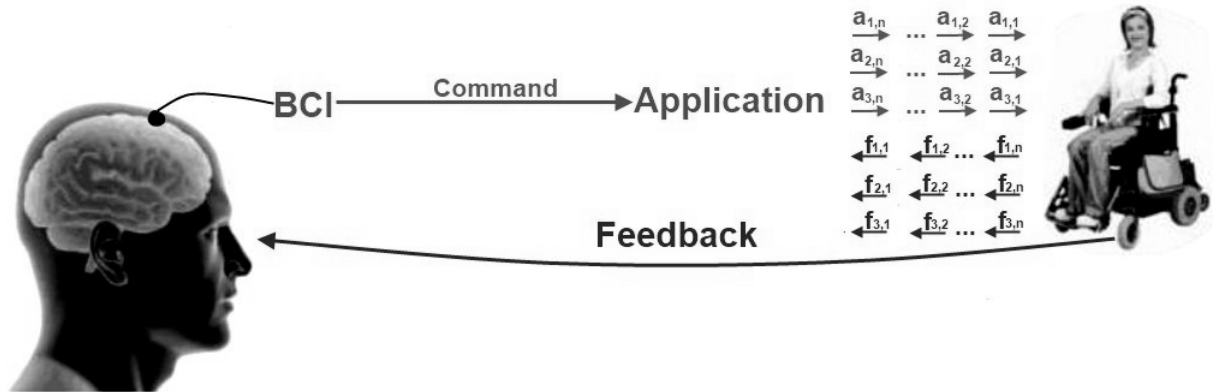


Figure 2.41: BCI output – goal selection [3].

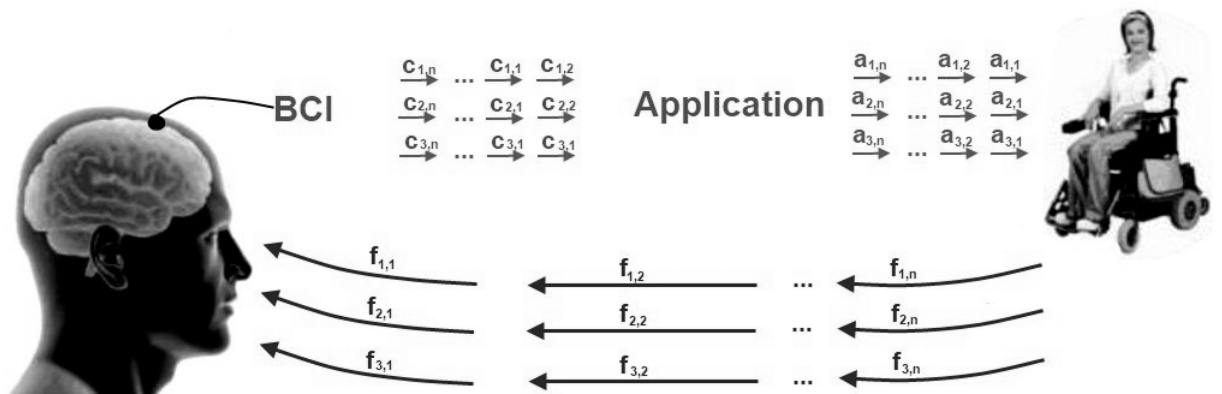


Figure 2.42: BCI output – process control [3].

# 3

## Theoretical Background

Research content of this dissertation relies on detecting the signals generated by specific parts of the human brain. The tasks that are being solved in this dissertation focus on bio-patterns associated with movement or its imagination. This section of the thesis provides a theoretical introduction to the fundamental components and operation of the human nervous system.

### 3.1 The Nervous System

As it is commonly known, humans belong to the biological species 'Homo Sapiens' which means a characteristic physiology of the body [40]. The nervous system consists of the central nervous system hereinafter called CNS and of the peripheral nervous system - PNS [13, 41]. The central nervous system, which will be described in the further part of this work, consists of two main parts - brain and spinal cord. The human brain and spinal cord will be presented in detail in this chapter in order to show their main role in the subject of the hereof work.

The human brain is the most unknown part of the human body, which makes it one of the most fascinating objects of scientific investigations [40, 41]. One of the features making humans special among other species – is their way of life, which does not involve only following the simple instincts, but also enables to do 'higher', more sophisticated tasks such as – walking on the moon and composing masterpieces of music or literature [42]. The way the humans feel, learn, move or simply exist has always been a subject of many questions, which remain without

an unequivocal answer [13]. The extent of the capability of the human brain is still unknown, despite the fact that every day brings new scientific discoveries regarding the complexity of this organ – able to control the whole body [42].

All tissues and organs consist of cells, which determine the functions of these. As a result it is highly important to describe cells of which brain consists - neurons [13, 42].

One of the main research subjects was human motor activity and its influence on the waves generated through the electrical activity of the brain – EEG. In order to describe the conducted work, it is required to present at least basic information about the brain construction and activity. The brain is also a main part of the whole nervous system and can be treated as its 'engine'.

Presented in Figure 3.1 is a scheme of the human nervous system [43], and Figure 3.2 shows the basic components of the whole human nervous system with the simple division into the central nervous system (CNS) and the peripheral nervous system (PNS) [44]. Various types of nerves are presented in more detail in the further part of this thesis.

### 3.1.1 Neuron

Neuron is the most important basic element of the nervous system and can also be called a nerve cell. The nerve cell differs from other cells not only with its structure but also its function [45, 46, 47].

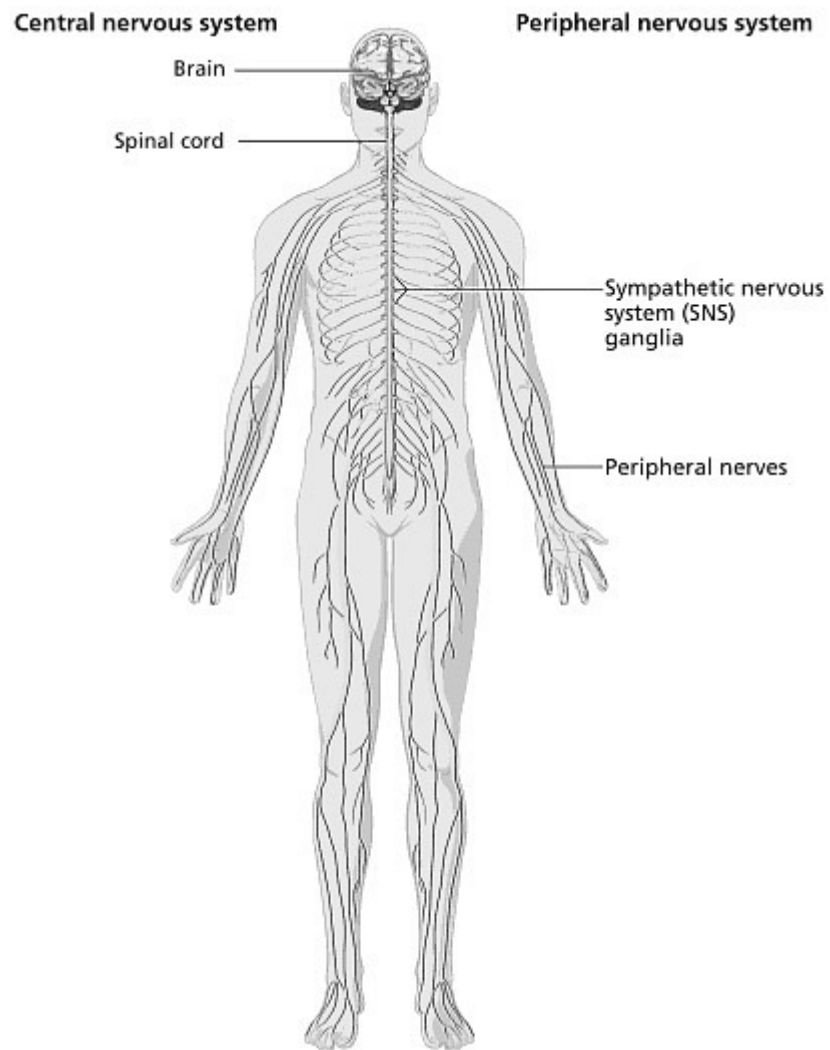
In the nervous system it is possible to differentiate the two main types of cells - neurons (mentioned above) and glia. They play a highly important role in mental and physical abilities [13, 42, 48].

As it was mentioned above – neuron is a basic working unit of the brain. Human nervous system consists of the amount between one billion and one trillion neurons, where an insect's nervous system is built of only one million nerve cells [42, 47, 49, 50].

Figure 3.3 presents a very basic schema of neuron. This schema shows that the main parts of a neuron are Soma and Neurites (Dendrites and Axon). A nerve cell should contain only one axon with at least one dendrite [48]. More detailed description will be presented in the further part of this chapter [13, 51].

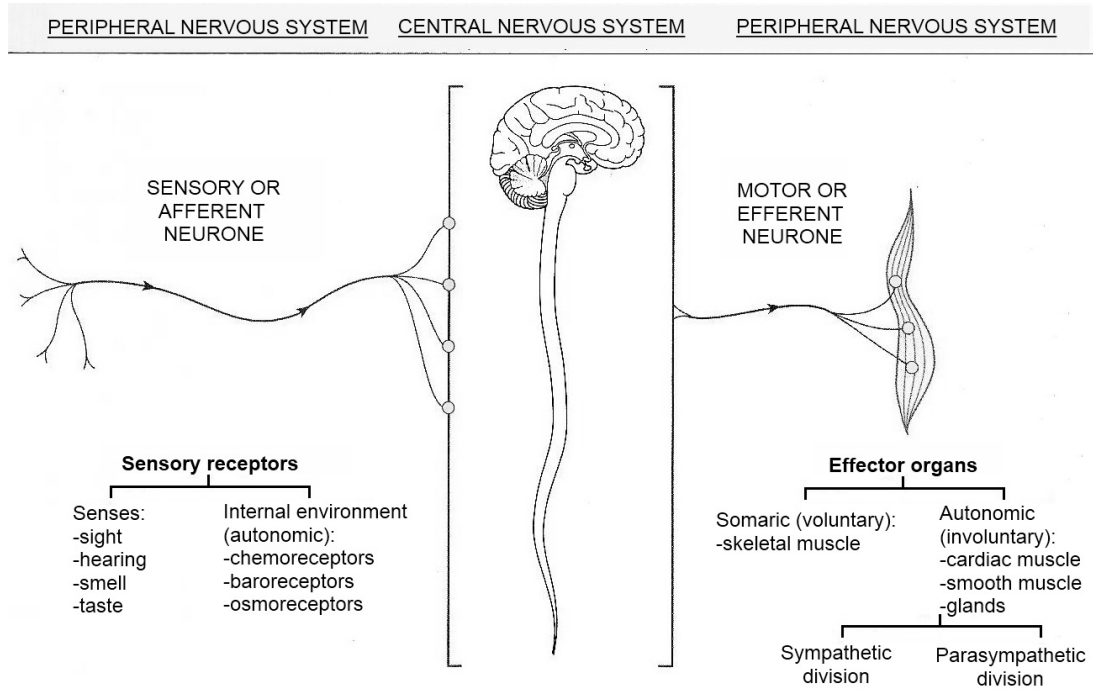
### 3.1 The Nervous System

---

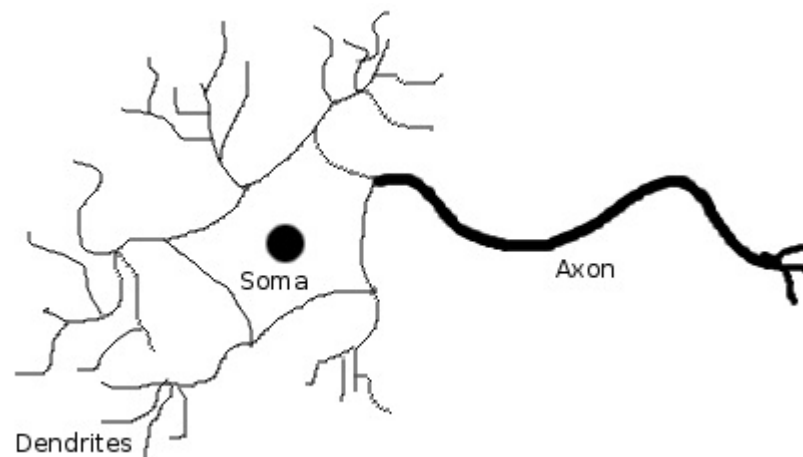


**Figure 3.1:** Basic scheme of the human nervous system [43].

### 3.1 The Nervous System



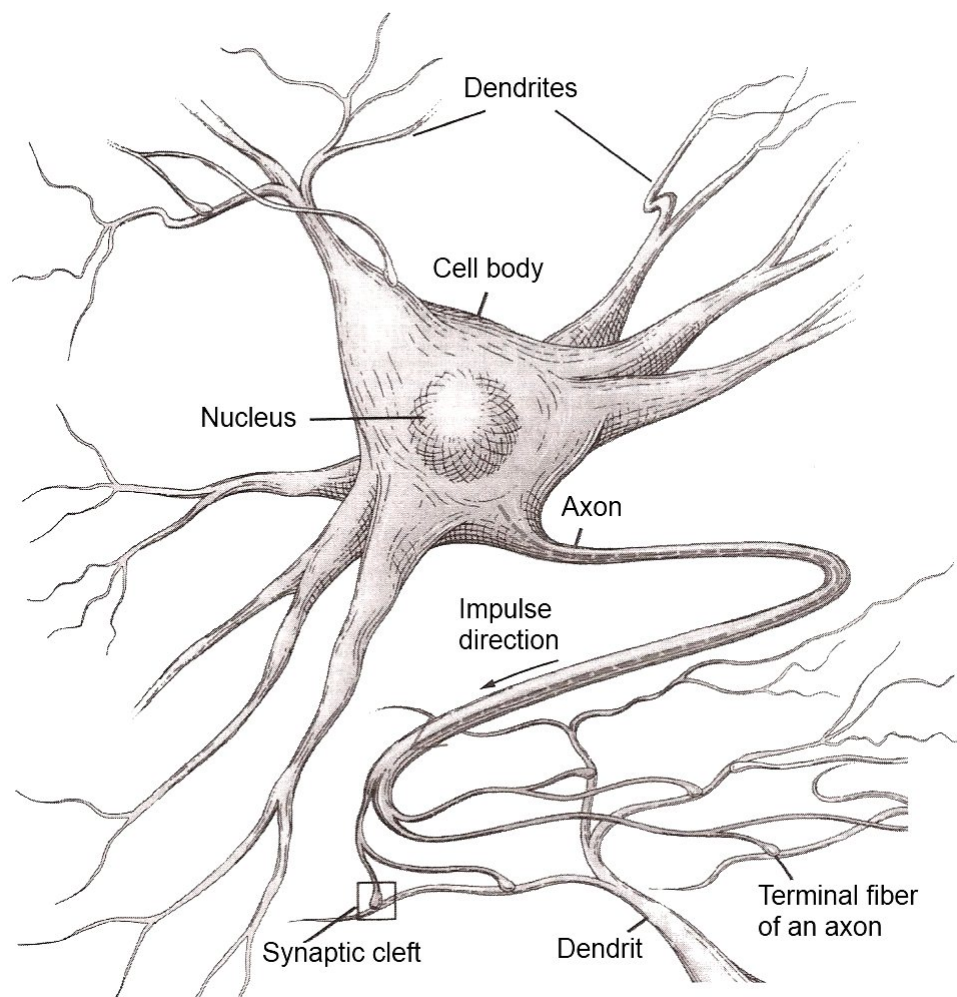
**Figure 3.2:** Functional components in the human nervous system [44].



**Figure 3.3:** Basic parts of a single neuron [13, 51].

### 3.1 The Nervous System

As mentioned above and presented in Figure 3.3 a neuron is made up of a cell body - called soma, and an electricity-conducting fibre - called axon. From axon rise at least one, but usually many small branches - dendrites, which end at nerve terminals. Neurons communicate with one another through their contact points - synapses. The concepts of Synapses and Dendrites come from Greek and mean 'to clasp together' for Synapses and 'branches of the tree' for Dendrites [42, 48].

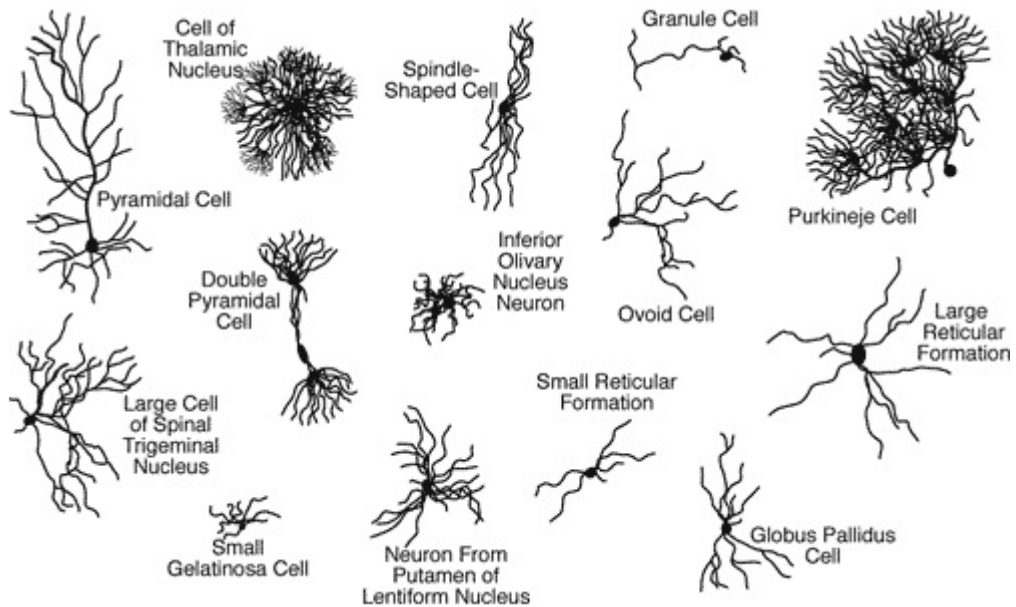


**Figure 3.4:** A typical human neuron [45, 49].

Figure 3.4 presents more detailed schema of a typical human neuron. It shows that the nerve cell consists of cell membrane, which surrounds the cytoplasm. In the central part of the neuron is its nucleus. The nucleus stores genetic informa-

### 3.1 The Nervous System

tion. This information is stored in the form of a chromosomes or chromatin – depending on the state of the cell. If the cell is in mitosis state – the information is stored in form of chromosome, where in the state of repose – chromatin. From the cell body arises axon. Axons are used for transmission and are very thin as they have between 0.2 and 20  $\mu\text{m}$  in diameter. The branches of the axon of one neuron transmit the signals to the another neuron at a side named synapse [45, 49]. The branches of only one axon are able to build up synapses with even thousand other neurons. A typical axon is simply an output part of a neuron. Dendrites are input elements of a neuron and their function is to receive the synaptic contacts from other neurons [42, 45, 49].



**Figure 3.5:** Various types of neurons [46, 52].

Figure 3.5 shows various types of neurons present in Cortex. The difference of them is based on their structure and the role they play in the nervous system. As mentioned above – in each neuron it is possible to distinguish dendrites and axon. Each type of neuron has different function in the nervous system. Cortex as an example - consists mainly of pyramidal neurons, which play an important role in memory and motor processes [46, 52].

The second main classification of neurons can be based on dividing them into three classes. The first class contains 'Sensory Cells', 'Sensors' and 'Receptors'.



### 3.1 The Nervous System

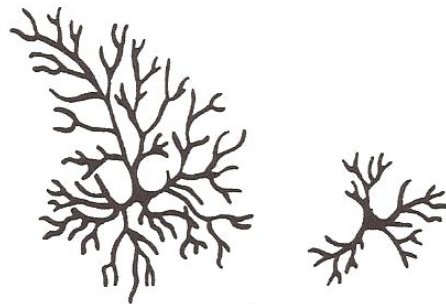
---

Their main role is to receive, filter and adapt the information. The second class contains only 'Inter-neurons' which process stimulations, control and store the information. The third class consists of 'Effector Neurons', which control muscles, tarsal glands and conduct neural modulation [49].

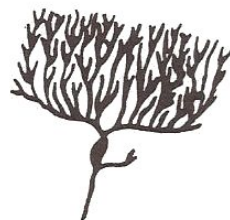
Division of neurons based on their functionality consists of the following types - Sensory, Motor and Associated neurons. The Sensory neurons transmit the information from the sensory organs to the spinal cord and the brain. This process is called an afferent transmission [48, 50]. The Motor neurons transmit the information from the spinal cord and from the brain to the muscles and glands, what is known as efferent transmission. Associated neurons are mostly based in the spinal cord and in the brain. Their function is to integrate and organise the information [50].

Figure 3.6 shows the schematic presentation of spreading the dendrites in a neuron. It is possible to specify the following types of dendrites types: isodendric, allodendric and idi dendritic [45].

Isodendric neuron



Allodendric neuron



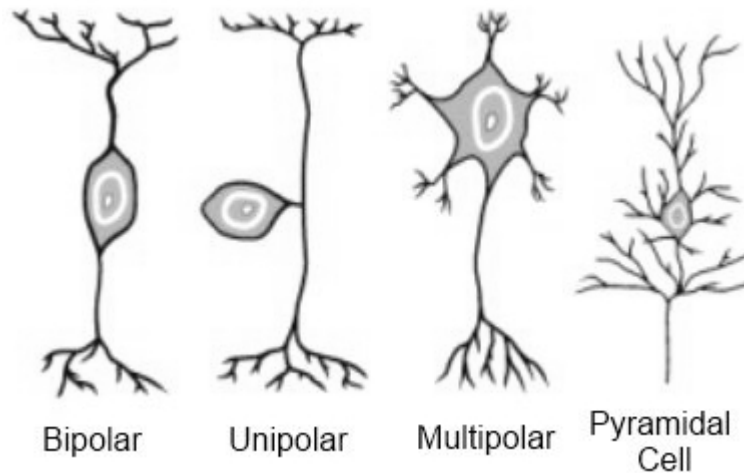
Idi dendritic neuron

**Figure 3.6:** Schematic presentation of dendrites spreading in a neuron [45].

### 3.1 The Nervous System

---

Neurons can also be classified according to their structure. It is possible to distinguish the following sorts of neurons: multi-polar, bipolar and unipolar [47, 48]. Some sources also add to this qualification – pyramidal neurons [53]. Pyramidal neurons are a form of multi-polar neurons, known as – pseudo bipolar cells [48, 53, 54]. Pyramidal neurons are an example Golgi I neurons – type of multi-polar cells. This type of nerve cells with axons extending considerable distances to the target cells [54, 55]. Figure 3.7 shows the structural classification of the nerve cell [48, 53]. This Figure presents the pyramidal cell as a separate type and does not differentiate it as a Golgi I or a variant of a multi-polar cell.



**Figure 3.7:** Structural classification of nerve cells [48, 53].

The Multi-polar nerve cells consists of only one axon with numerous dendrites (at least two) [54]. Multi-polar neurons are mostly present in the brain and spinal cord [47, 48, 54, 55]. The second type are the Bipolar neurons, which consist of only one axon and only one (but highly branched) dendrite, occasionally – two dendrites [47, 48, 54]. They are the least common type of nerve cells. The third type of neurons is Unipolar neurons, which are always sensory neurons and transfer the information towards the Central Nervous System [47, 48]. Unipolar neurons consist of only a single neurite, which enables the division of a short distance from the cell body into two branches [55].

It is also important to mention the main types of nerve cells according to their functional classification: sensory or afferent nerves, motor or efferent nerves and

the mixed nerves [44, 48, 54].

Sensory or afferent nerves play a main role in responding to the various stimuli - both external and internal. The stimulation releases the reaction to it through the generation and transmission of an impulse [4, 44, 54, 55].

Motor nerves occur in the brain, spinal cord and autonomic ganglia. Their main role is to transport the impulses to the effector organs, such as muscles or glands. We are able to differentiate the following two types of the efferent nerves: somatic and autonomic nerves [44, 47, 48].

Somatic nerves are included in the reflex and voluntary skeletal muscle contraction, where the autonomic nerves (divided into sympathetic and parasympathetic) are embraced in the smooth muscle and cardiac contraction and glandular secretion [44, 47].

It is also possible to distinguish a type of nerve cells called – mixed nerves. The mixed nerves are the various (motor and sensory) nerves embedded in the same sheath of connective tissue outside the spinal cord [44, 48].

### 3.1.2 How do neurons work?

The neurons have an important function in the nervous system and their work affect the whole organism. As it was mentioned above, the neurons play a role of transmitters, which can both – send and receive information. Electrical impulses are sent along the axons. Some of the axons are being covered with an insulating 'myelin' sheath able to speed up the transmission of electrical signals [42, 45].

There are certain nerve cells that, as opposed to most of neurons, do not possess axons; some of neurons have axons that are able to receive information and dendrites that can conduct impulses or even form transmissions with other cells. That makes the identification or classification of their functions slightly complicated. A classic example of an atypical neuron is a photo-receptor. The way the photo-receptors work is based on external stimulus such as illumination and not on input from another neuron. Photo-receptors do not possess axons despite being classified as nerve cells [56].

As it was mentioned in the previous part of this dissertation - neurons transmit electrical signals. Nerve impulses enable opening and closing 'ion channels' –

### 3.1 The Nervous System

---

molecular water-filled tunnels, which pass through the cell membrane - and as a result enable ions (electrically charged atoms or small molecules) to enter or leave the target cell. As a result occurs an electrical current, which produces very tiny voltage changes across the membrane [42, 48, 56].

A small difference in electrical charge between the outside and inside of the cell depends on the ability of neurons, as its main role is to receive, process and send the information in the form of electrical impulse. Each nerve cell is able to receive the information from other neurons or other cells - such as receptors, or directly from the external environment through the dendrites. The information is being then transferred via axon [42, 45, 50].

The information received by neurons are later stored in the form of electrical or chemical signals. The axon's 'myelin' layer, which consists of lipids, is of great importance in this process and plays the role of an isolator. Inside and outside the cell are accumulated charges - anions (negative charges) inside and - cations (positive charges) outside the cell. This may cause the difference of potentials between the inside and outside of the nerve cell [42, 46, 56].

The 'myelin' layer is not an absolute isolator and through various complex physiochemical phenomenon there is a possibility of passing the ions what may result in balancing the potential on the both sides of the cell's membrane. The nerve signals are transferred over Ranvier grooves and enable faster transfer of the signal. This phenomenon is being called depolarisation of the neuron [42, 56]. The 'myelin' layer in the CNS is produced by the Oligodendrocytes [48].

Above outlined that local changes in the nerve cell are a base of activity of neuron. The potential is growing fast and then returns with a various speed into the output state, what is being known as an active potential. The movement of an active potential evoked by an impulse is being the essence of transmitting the information. The speed of this process may vary depending on axons. An important feature of the stimulus processing in axon is that the active potential during its journey neither loses its strength nor expires [42, 46, 56].

The way of transmitting signals is the same for the whole nervous system, but the type of information (or order) depends on the type of single neurons or groups of neurons, which are stimulated. The neurons are able to pass not only the stimulation but also its strength. The strength of the stimulation can be

transferred into the frequency of nerve impulse. The weak stimulations evoke the impulses with a low frequency, the stronger stimulations are able to evoke the impulses with a high frequency [46, 50, 57].

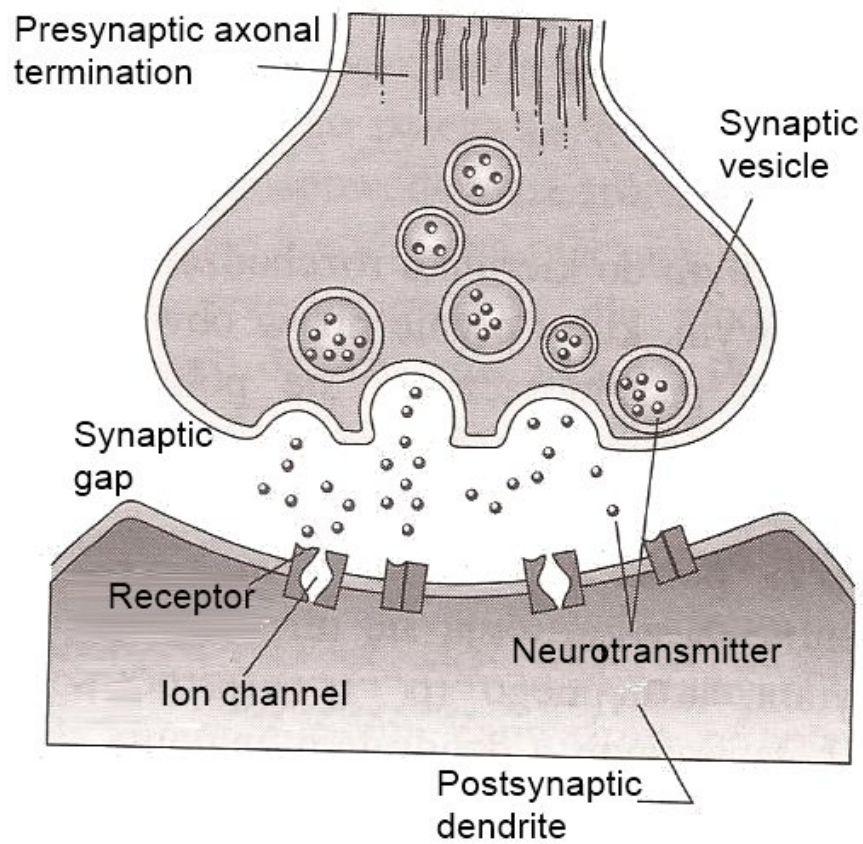
When an impulse reaches the synapse, an interesting phenomenon occurs. The axon of the impulse transmitting neuron does not connect directly with a body of the receiving cell because there is a small gap between them (approx. 10-15  $\mu m$ ) [42, 46, 50].

In the synapses the signals are being transferred in only one direction - from axon of one cell into the dendrite of the target cell. The balance is being asserted only because of the fact that the cell body contains a lot of dendrites, which contain a lot of connections with axons. It is a very rare phenomenon, when the neuron is stimulated only through the impulse coming from only one nerve cell. This phenomenon counteracts the possible damage of nerve cells and does not affect their activity, because their functions would be overtaken by the neighbour cells [42, 46, 56].

Figure 3.8 presented the schema of a synaptic transmission. The active potential causes the emission of molecules neurotransmitters from the synaptic vesicles into the synaptic gap. The ion channels in the post-synaptic dendrite open and it may cause the origin of a new active potential, which would move to the post-synaptic neuron [46, 48]. There is an individual schedule of synaptic transmission for every human same as – individual personality [46, 58].

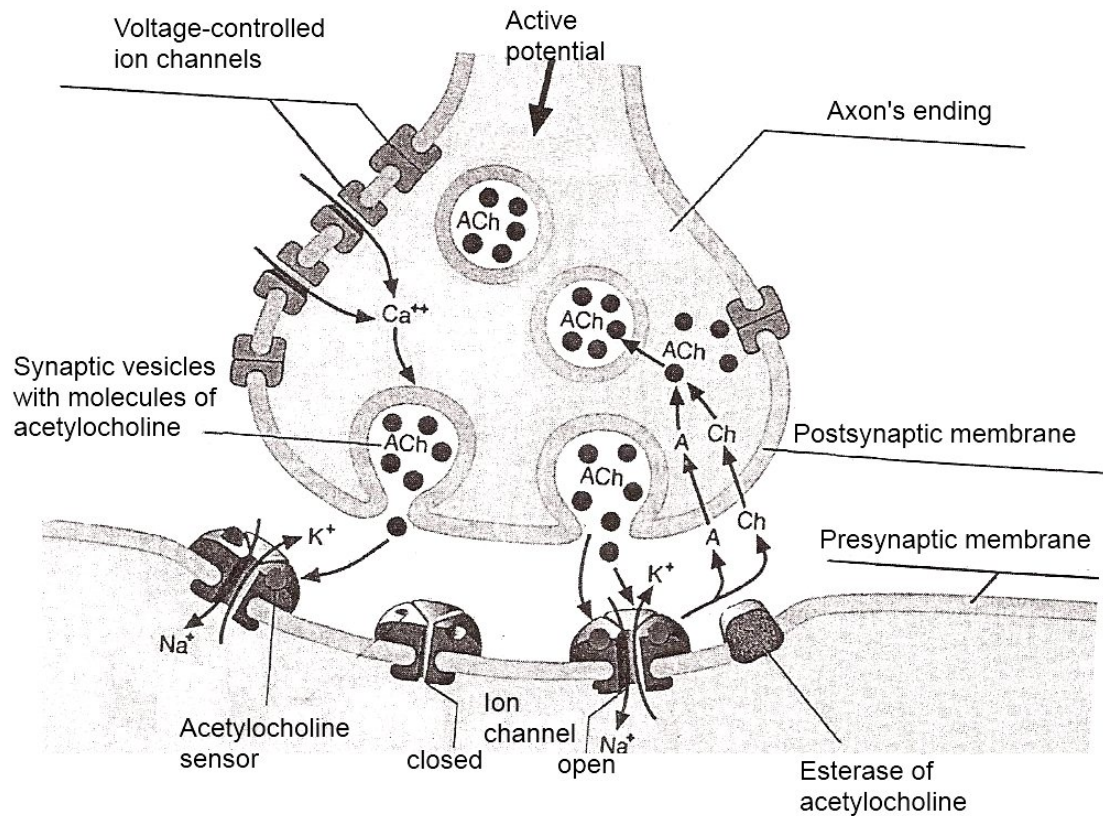
The topology synaptic network is not constant in time. The location and efficiency of synapses changes throughout the learning process. Between the neurons communicating with each other, occurs synaptic transmission, but in case the nerve cells are being seldom used and there is no such communication - the synaptic transmission undergoes a process of degradation. The synaptic transmission may also be affected by aging or various illnesses [46, 56].

The nerve impulse can be transferred from one cell to another by chemical or electrical route. The chemical synapses enable the transfer of electrical stimulation between the membrane of two cells - pre-synaptic and post-synaptic. The delay in potential transfer between the cells is characteristic for the chemical synapse. The reason for the delay relates on the fact that the transformation of an active potential into a chemical signal, the transfer of this signal and then



**Figure 3.8:** Synaptic transmission in a nerve cell [46].

again a transformation of it in an active post-synaptic potential requires time [42, 50, 56].

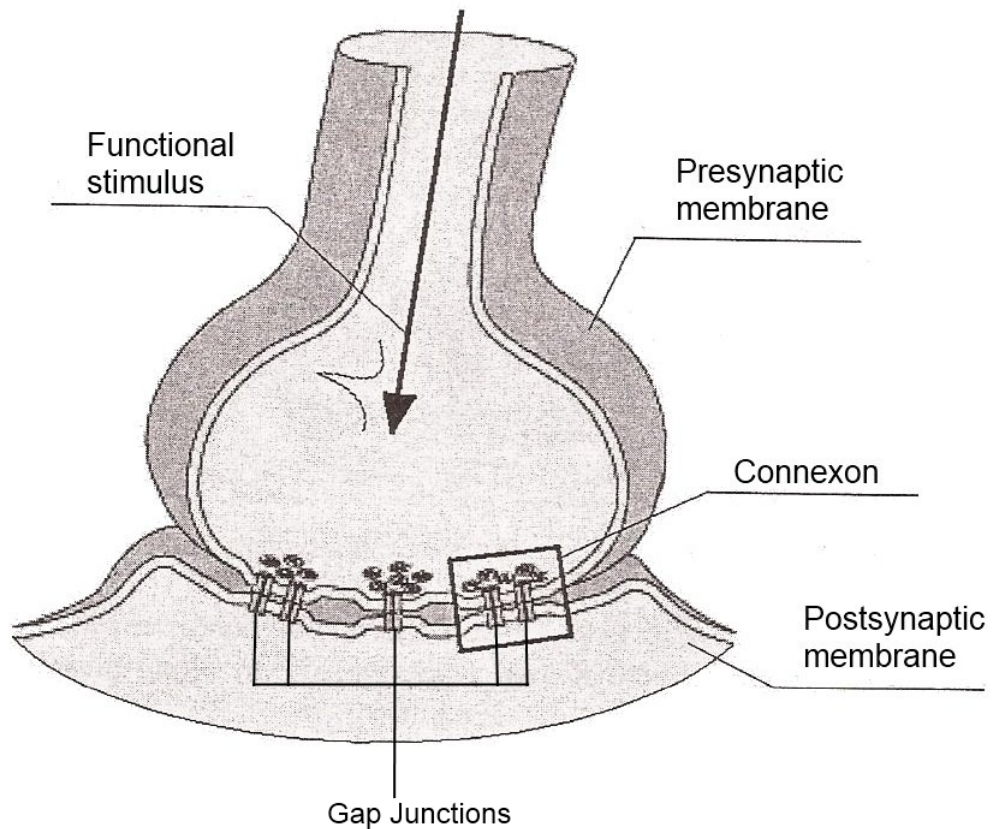


**Figure 3.9:** Chemical synaptic transmission in a nerve cell [48, 50].

Figure 3.9 presents a scheme of chemical synaptic transmission occurring in a neuron. Post-synaptic membrane contains ion channels controlled by the acetylcholine receptors [50]. The active potential opens the calcium channels and the calcium ions ( $Ca^{++}$ ) are leading to the emission of the neurotransmitter - acetylcholine (ACh). Acetylcholine occurs in synapses in place of connection between the nerve cells. Calcium ions ( $Ca^{++}$ ) are responsible for depolarisation of neurons – but only spiral neurons in muscles, what is a result of muscle depolarisation. The information transmitted by calcium ions is processed by the cell and not by synapse. The acetylcholine molecules activate the ion channels. The opening of the ion channels causes the flow of sodium ( $Na^+$ ) or potassium ( $K^+$ )

ions. This phenomenon leads to the change of polarisation, what can be either depolarisation or hyperpolarisation [42, 50].

A different transmission system in neurons is being conducted by the electrical synapses. For every electrically mediated synaptic transmission, the more characteristic the lack of synaptic delay. The electrical synapses enable the communication in both directions, what can be an advantage in comparing them to the chemical synapses. The disadvantage is that the conducted electrical impulses do not have the gain, but the signal in the post-synaptic cell is the same or lower than it was in the originating neuron [50, 55, 56].



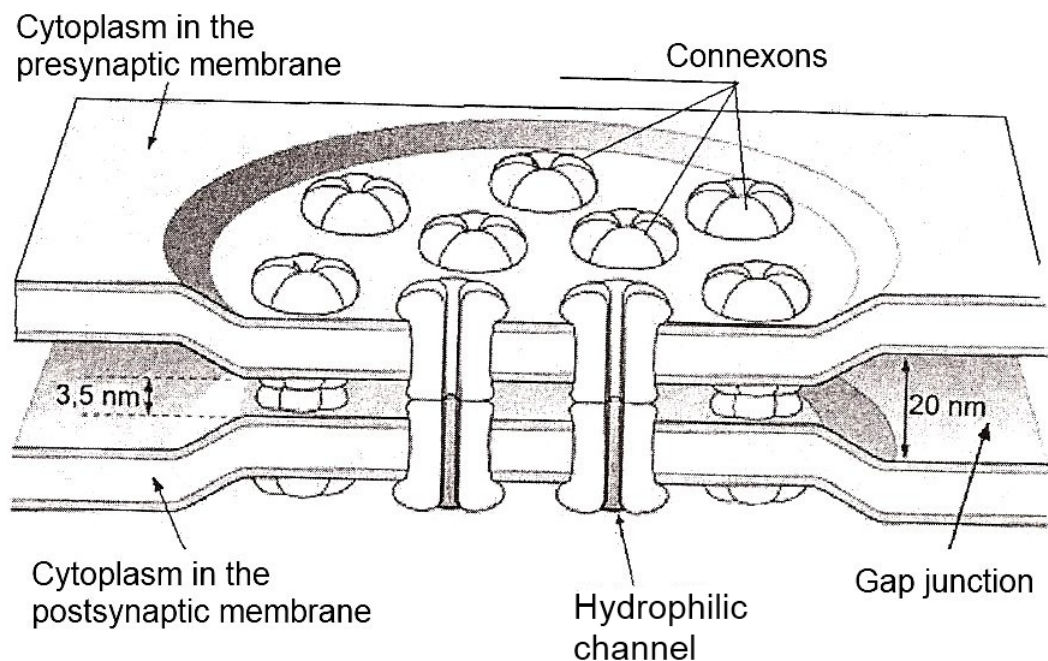
**Figure 3.10:** Structure of an electrical synaptic transmission [50].

The electrical synapses are more frequently found in the neural systems that need a response as fast as possible [56, 57]. Figure 3.10 presented a simplified structure of an electrical synaptic transmission [50]. As it was already stated the



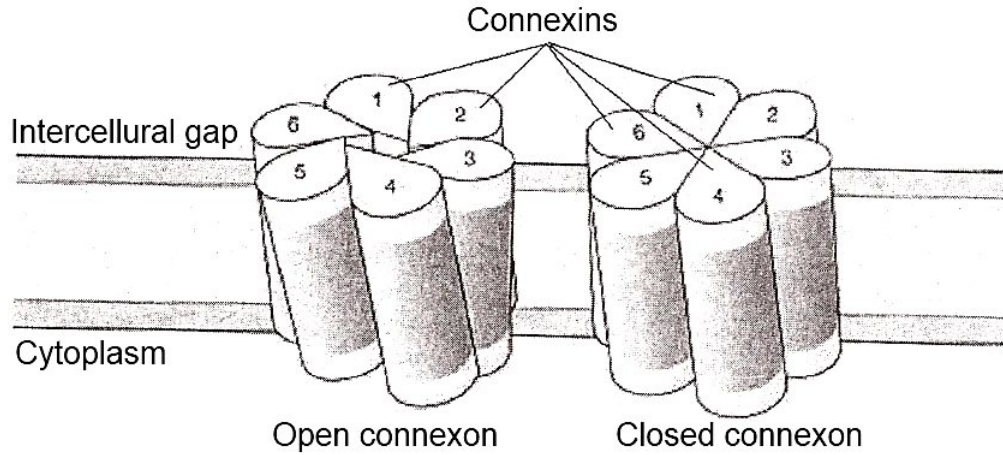
### 3.1 The Nervous System

electrical synapses allow the impulse transmission to be bidirectional although some of the gap junctions allow the communication in the only one direction [55, 56]. A gap junction can also be called a nexus junction. The pore of the gap junction channel allows ions and medium sized molecules to flow from one cell to another [56].



**Figure 3.11:** Structure of a connexive connection [50].

Gap junctions consist of two connexons with four-pass membrane-spanning protein subunits - connexins. The connexons contain six connexins (Fig. 3.12). Figure 3.11 shows the structure of a connexon connection. Fig. 3.12 illustrates a connexon - in its both possible states - open and closed [50, 56].



**Figure 3.12:** Connexon in an open and closed state [50].

### 3.1.3 Glia

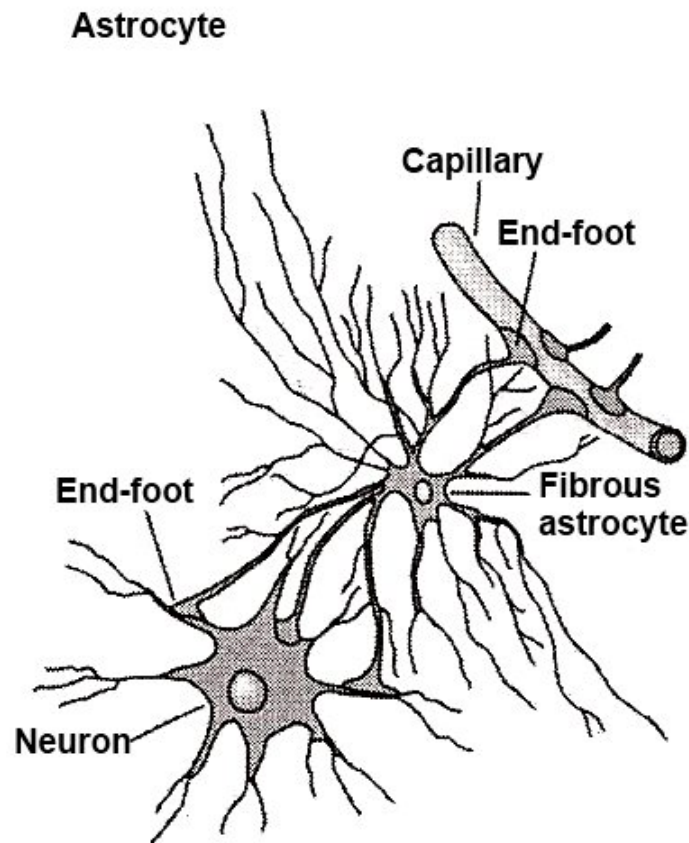
Glial cells are an example of non-neuronal cells. In opposite to neurons - the glial cells do not possess axons nor dendrites. Due to their lack of axons and dendrites they are not directly connected with nerve cells. Glial cells play numerous roles in the nervous systems, as an example - they form the 'myelin' layer of neuron [56].

Other names for glial cells are neuroglia or just simply glia. The term comes from a Greek word, which means glue. Glial cells provide a protection for neurons, that is why in e.g. the human brain there is one glia for every nerve cell, but in the cerebral gray matter - only one glia for two neurons [45, 48].

As it was stated above the glial cells play the role of glue in the nervous system, but it is not their only function. It is possible to specify the four main functions of glial cells - they surround nerve cells and hold them in place, they are also responsible for supplying the nutrients and oxygen - necessary compositions for a neuron, they also insulate neurons from each other and the last - they are able to destroy pathogens and remove dead neurons [45, 56].

It is possible to distinguish three principal types of glial cells in the central nervous system (Fig. 3.13, Fig. 3.14 and Fig. 3.15), these are Oligodendrocytes, Schwann Cells and Astrocytes. Astrocytes play a crucial role in clearance of

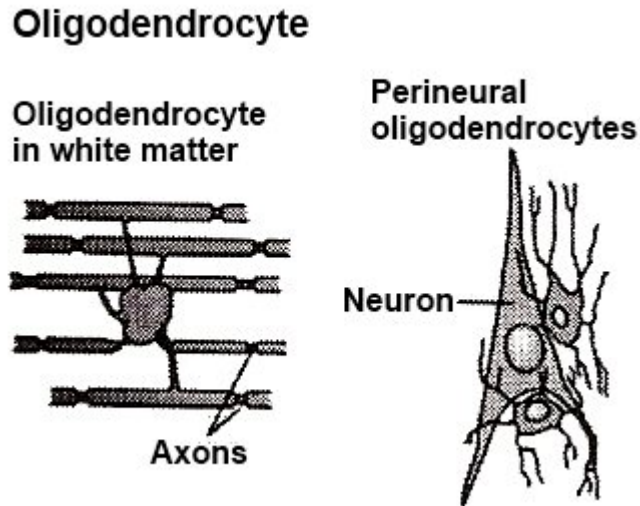
neurotransmitters, this may prevent from a toxic build-up of particular neurotransmitters like excitotoxicity [45, 48, 49, 54].



**Figure 3.13:** Schema of an Astrocyte [45, 49].

Presented in Figure 3.13 was a schema of Astrocyte [45, 49]. Astrocytes are the most numerical nonneuronal cells in the central nervous system. They have a characteristic star-shape and a quite broad end-foot. It is believed that Astrocytes have a nutritive function as they are put into contact with both neurons and capillaries, they also play a very important role in building the blood-brain barrier [49].

The second principal type of glial cells is Oligodendrocytes. This cell was shown in Figure 3.14. They are a very small cells and have only a few processes. In the white matter their only function is to provide the 'myelin', in the gray matter - they only have to surround the cell bodies of neurons. Just a single



**Figure 3.14:** Schema of an Oligodendrocyte [45, 49].

Oligodendrocyte is able to wrap membranous processes around multiple axons and as a result - insulate them with a 'myelin' shield [45, 49].

The third main part of neuroglia are, already mentioned above, Schwann Cells. They play an important role in the peripheral nervous system as they furnish the 'myelin' layers that insulate axon in neurons there [49, 54]. They are positioned along the axons, what is presented in Figure 3.15 and form about  $1mm$  long 'myelin' cover forming inner tongue of the Schwamm cell [49].

Glia cells are partners to nerve cells as they play a crucial role in their development. Glia cells have also a part in process of repairing nerve cells after injury. The Astrocytes enable the production of inhibitory molecules that are responsible for the re-growth of a damaged axon. The Schwann Cells may support the re-growth of an axon by regressing to an earlier developmental state. Spinal cord is an example of an organ able to self-repair after a severe damage thanks to the glial cells [45, 48, 56].

### 3.1.4 Central Nervous System (CNS)

The human nervous system consists of two systems - Central Nervous System (CNS) and Peripheral Nervous System (PNS). The nervous system aims to de-

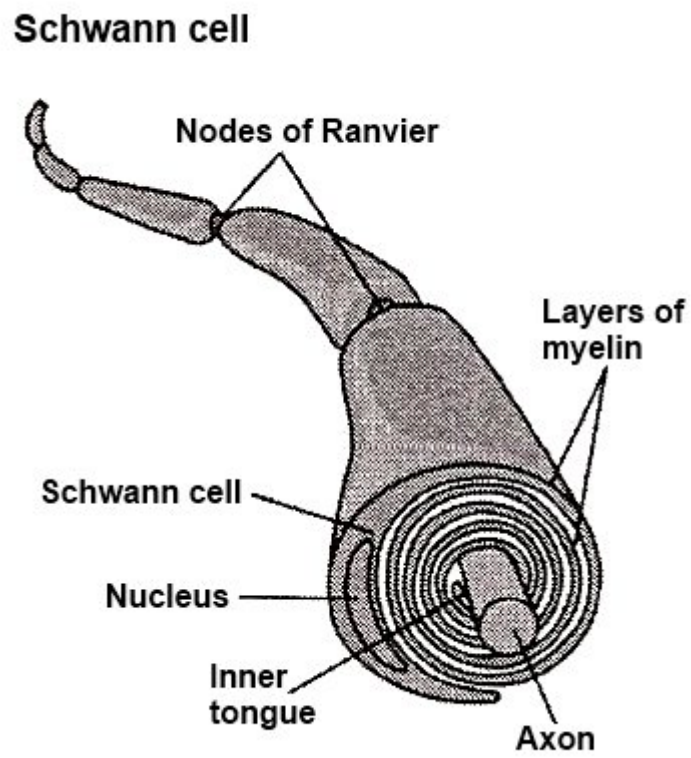
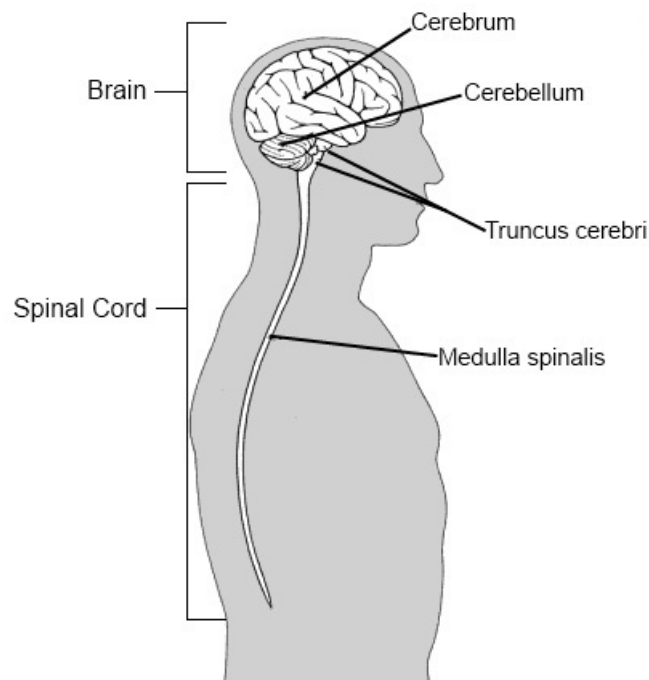


Figure 3.15: Schwann cell wrapped around an axon [49].

tect the features of both external and internal environments and processes the obtained information for the purpose of body processes [42, 59, 60].

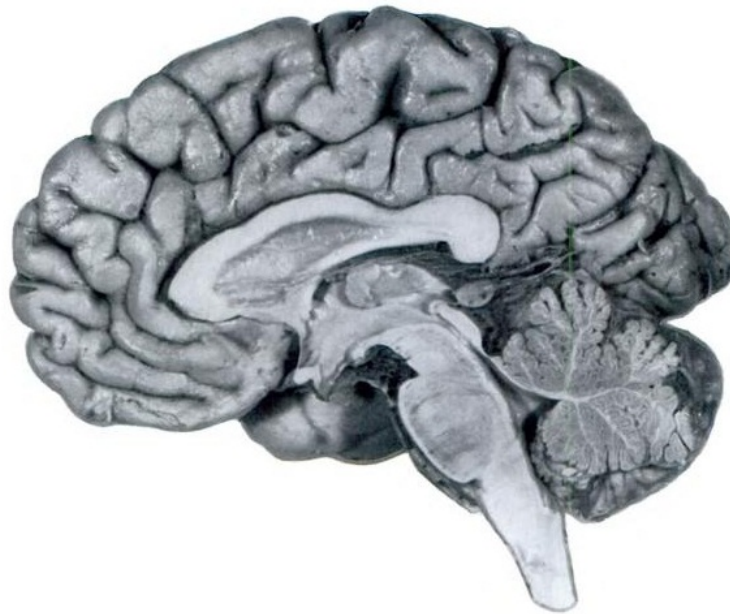
The CNS consists mainly of the spinal cord and the brain. Below – Figure 3.16 presents a simplified scheme of the CNS with its division onto the spinal cord and the brain. Both – spinal cord and brain will be described in more detail in the further part of this dissertation [43, 61].



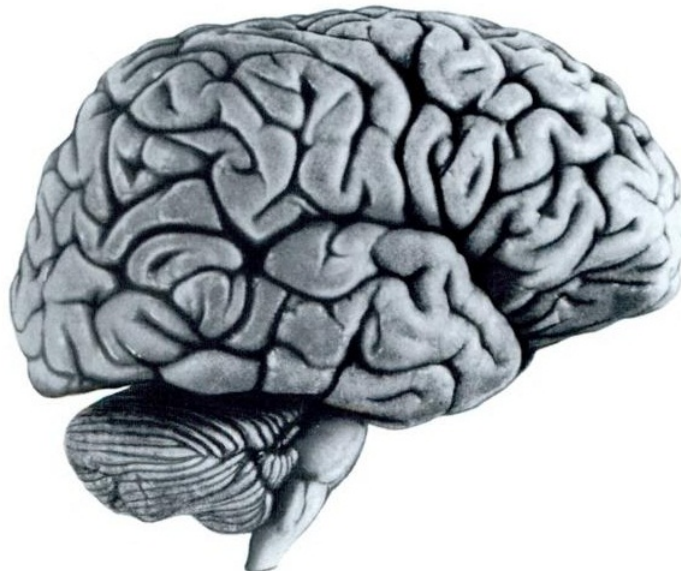
**Figure 3.16:** Central Nervous System main parts [61].

### 3.1.4.1 Brain

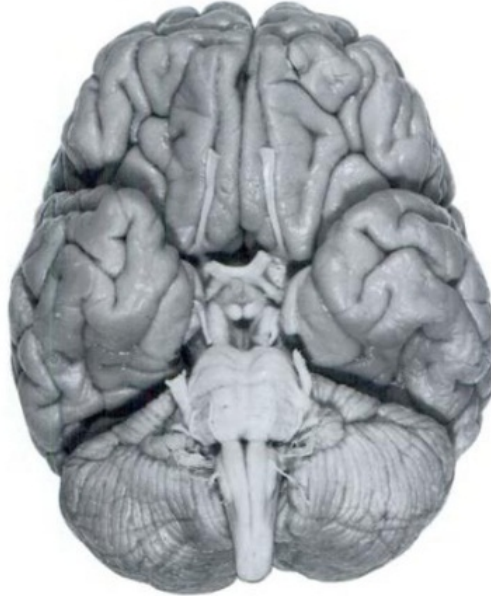
The human brain weighs around 1.5 kg, what is about the amount of 2% of the body weight, or according to some sources – one-fifth of the average human body weight [44]). It contains over hundred billion nerve cells and is the least explored human organ. Currently the way how a brain works is still unknown [62, 63]. The human brain is, compared to the brains of other mammals, of quite a big size and its main function is to generate behaviour or movement [4]. The brain also controls functions of the Central Nervous System (CNS) [43]. In Figures 3.17, 3.18 and 3.19 photographs of the human brain are presented [62].



**Figure 3.17:** Midsagittal section of the human brain [62].



**Figure 3.18:** Lateral surface of the brain [62].



**Figure 3.19:** Basal surface of the brain [62].

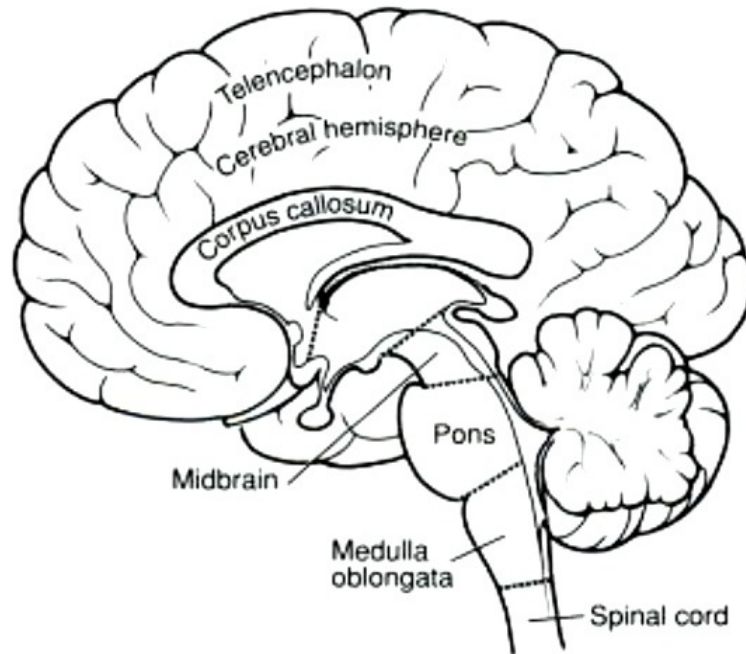
Figure 3.20 shows schema with the main parts of the CNS. The main brain subdivision originates from vesicles, which are present in the embryo, called 'telencephalon', 'diencephalon', 'mesencephalon', 'metencephalon' and 'myelencephalon'. Cerebral hemispheres develop from telencephalon, diencephalon develops into between brain, mesencephalon into midbrain, metencephalon into pons and cerebellum and myelencephalon into medulla [48, 62].

Figure 3.21 presents a section of a human brain. The most structures in the human brain are paired, so each side of the brain looks like a mirror reflection of another one [4, 43, 62].

The brain consists of the following parts: cerebrum, brainstem and cerebellum [48, 62]. The largest part of the human brain is formed of the cerebrum - cerebral hemispheres. Cerebrum is covered with a 3 mm deep layer of gray matter - cerebral cortex. The largest density of neurons is in the gray matter. Under this layer is located white matter - this is a layer of fibre tracks with axons traveling back and forth the cortex [43, 48, 62].

Each cerebral hemisphere consists of four lobes - temporal lobe, frontal lobe, parietal lobe and occipital lobe. Processes of thinking, speaking, showing emo-





**Figure 3.20:** The main division of the CNS [62].

tions, motor activity (also plans of it) are being controlled by the frontal lobe. Input from eyes as a vision is being received and interpreted by the occipital lobe. Impulses from skin, joints and muscles are received and interpreted by the parietal lobe. The parietal lobe is also available to interpret those impulses as sensory messages such as inter alia pain or touch. Visual and auditory inputs are integrated with the somatosensory input - also a part of the parietal lobe, but are interpreted as a sound in the temporal lobe. Understanding of speech, feeling emotions, perceiving colours and forms is also conducted in the temporal lobe [4, 43, 48].

In Figure 3.22 the following are shown: frontal lobe, parietal lobe, temporal lobe and occipital lobe. This figure (Fig. 3.22) also illustrates their position in the human brain [43].

In Figure 3.23 functional areas of a human brain were presented [64]. The electrode placement for the BCI purposes is related to those areas.

The above mentioned lobes are being marked up from one another sulci such as

### 3.1 The Nervous System

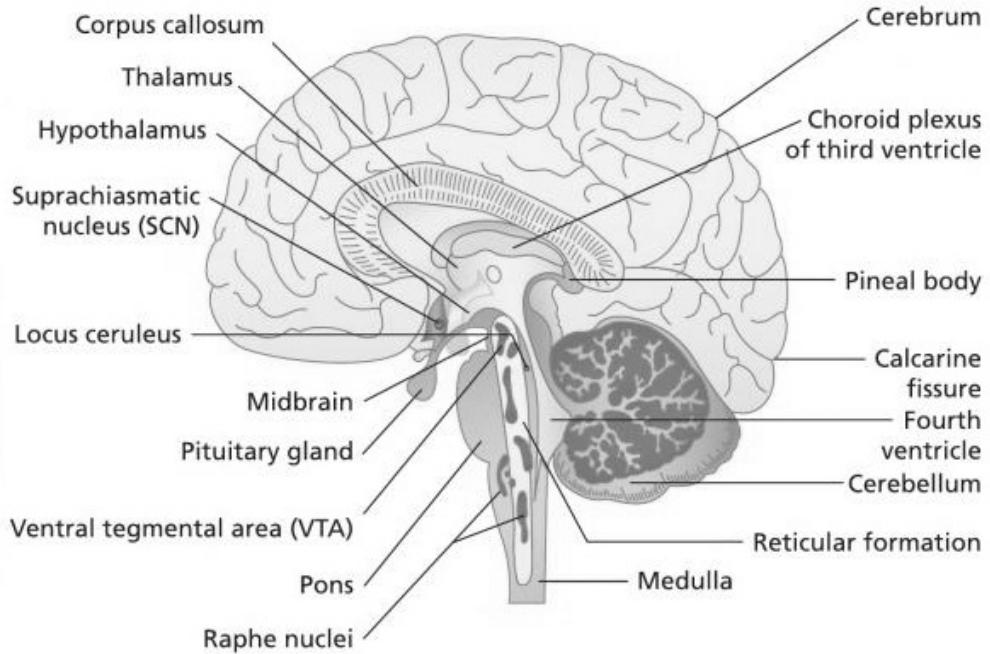


Figure 3.21: Section of the human brain [43].

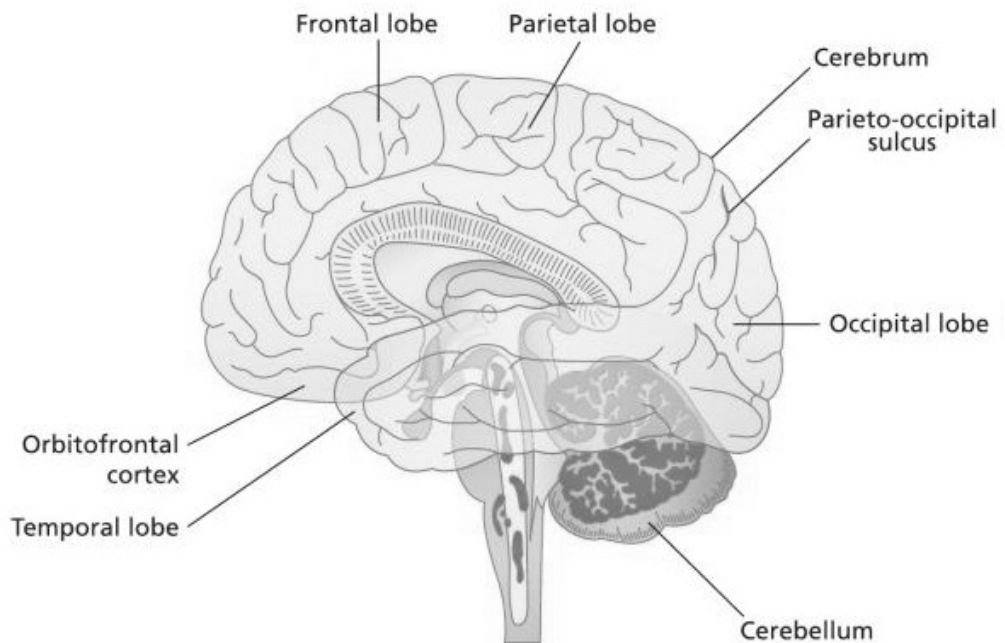
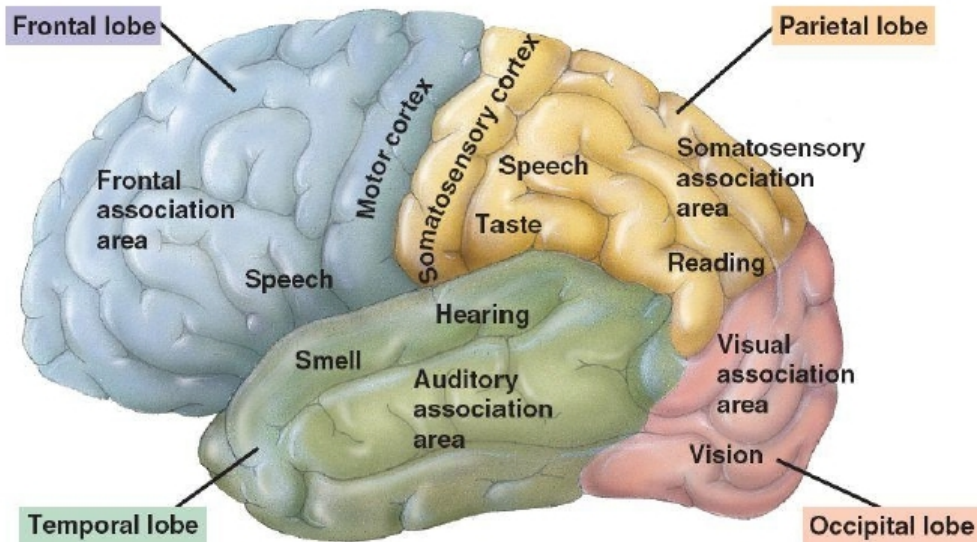


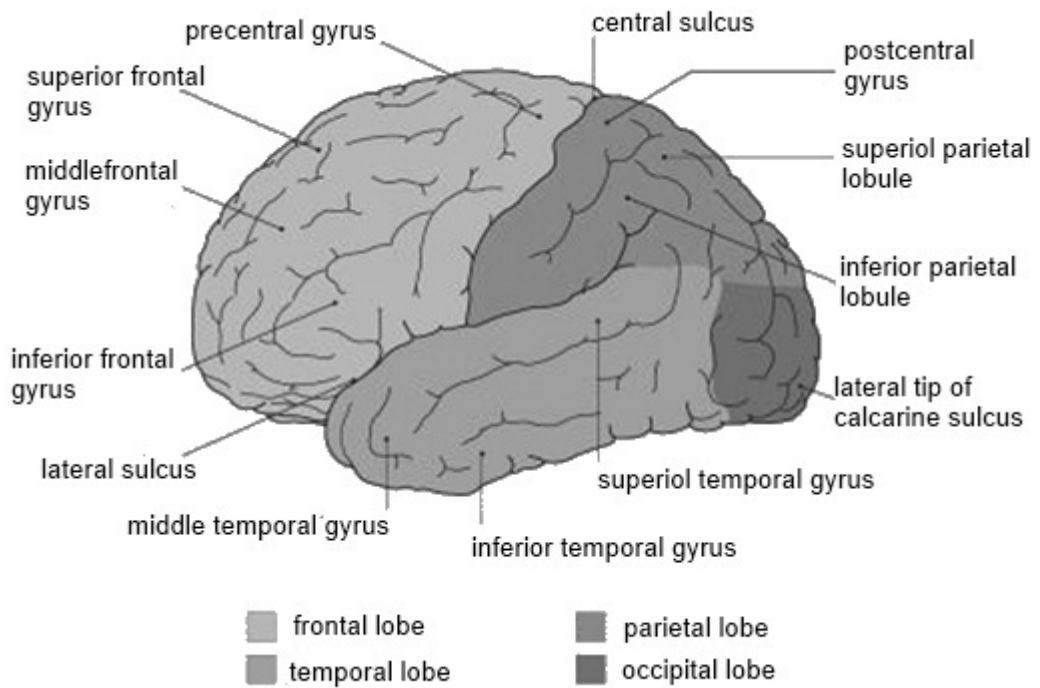
Figure 3.22: Lobes in human brain [43].



**Figure 3.23:** Diagram of functional areas of a human brain [64].

sulcus of Sylvius, central sulcus of Rolando, cingulate sulcus and parietooccipital sulcus. Figure 3.24 below showed the lateral surface of the brain and again the position of the lobes [59].

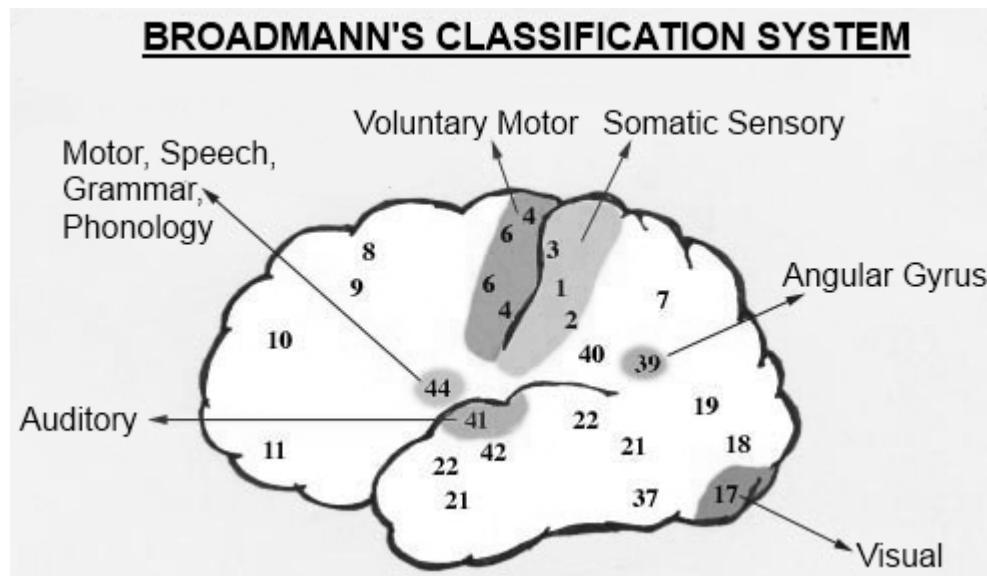
In the early part of the twentieth century Brodmann carried out some studies on electrical probing of the epileptic patients' cortices. His studies resulted in creating a map of cortex covering lobes of each hemisphere [65]. The frontal lobe of the human brain is identified with cognitive functioning and speech and language [64, 65]. Areas 1, 2 and 3 – located on primary sensory strip – are somasthetic areas, what means they are primary sensory areas for touch. Area 4 – is a primary motor area. Areas 5, 7 and 40 – are considered to be pre-sensory areas where somatosensory processing takes place. Area 6 is a supplementary motor area. Area 8 is an anterior of the pre-motor cortex. It is involved with visual reflexes such as pupil dilation and constriction and facilitated with eye movement. Areas 9, 10 and 11 are involved in cognitive process such as reasoning and judgment. Areas in the Parietal Lobe are related to somatosensory processes, where areas involved in the processing of auditory information and semantics and smell are found in the Temporal Lobe. Area no. 17 is the primary visual area. Areas 18 and 19 – secondary visual areas, where visual processing occurs. The



**Figure 3.24:** Lateral surface of the human brain [59].

### 3.1 The Nervous System

Occipital Lobe contains areas processing visual stimuli. Areas 21 and 22 are auditory association areas. Both areas consist of two part – one half of each area lies on either side of area 42. Areas 21 and 22 can be called Wenicke’s areas. Area 37 is a part of the temporal lobe, lesions on this area may cause anomia. Area 39 is the angular gyrus. Area 41 is the primary auditory area and called Heschl’s gyrus. Area 42 is involved in speech detection and recognition. The processing done in area 42 is more detailed than the one done in area 41. Areas 44 and 45 are Broca’s areas [65].



**Figure 3.25:** Brodmann’s areas [65].

In the cerebral hemisphere there are some important groups of neurons with similar functions hereinafter called 'nuclei' (in the CNS) or 'ganglion' (in the PNS). In the temporal lobe we can find the hippocampus, which is responsible for processing and interpreting the memories and emotions. The Amygdala is a part of the hippocampus which enables us to generate a response for stressful events and to express the emotions. The main function of the basal ganglia is to control the movements [43, 48].

Underneath the cerebral hemispheres are located the groups of nuclei known as thalamus and hypothalamus. Together the thalamus and the hypothalamus form the diencephalon. The main function of the diencephalon is to control and

## 3.1 The Nervous System

---

release the hormones from the pituitary gland as well as to integrate the functions of the autonomic nervous system [43, 47, 48].

Below the diencephalon is located the brainstem, which consists of the midbrain, the pons and the medulla. The area of midbrain is responsible for eye movement, regulation of the body temperature, pain perception or organisation of some simple movements. Together with the pons the midbrain also supports the control of the sleep-awake cycle. The areas initiating the activities such as dreaming or sleeping are within the pons, where the medulla is responsible for controlling the position of limbs and regulating the breathing or heart rate [43, 48, 62].

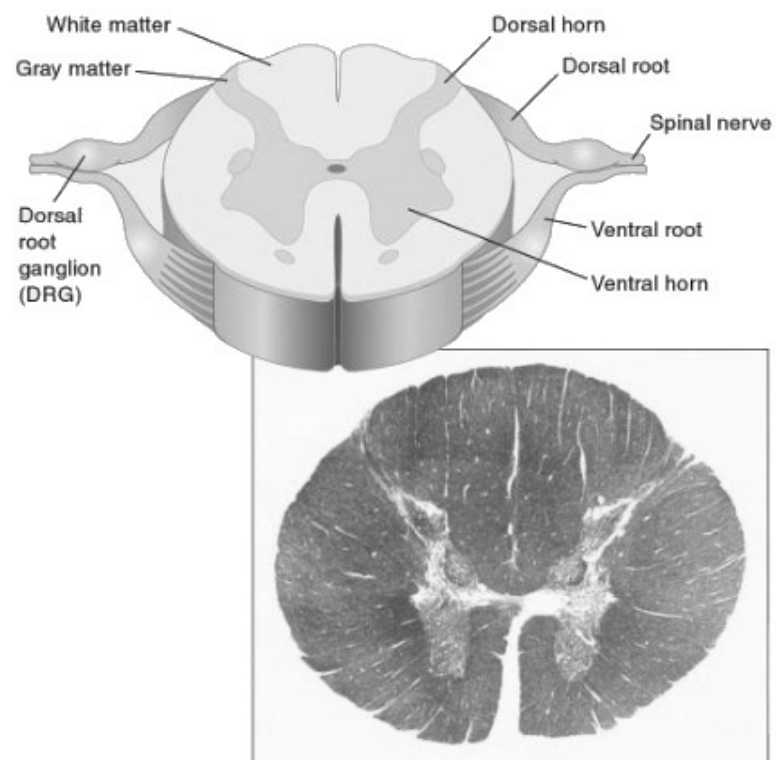
Below the occipital lobe in the human brain is located the cerebellum. Cerebellum's structure may seem the smaller version of the cerebrum as it also consists of two hemispheres and is made up of thin cortex. The cerebellum plays a large role in human motor activity - such as coordination of movements, maintenance of posture and learning of motor skills. The cerebellum may also be involved in processes such as thinking memory and speech [43, 48].

To sum it all up - the main function of the brain is to produce movement and to 'understand' the surrounding environment, where this movement takes place. It requires a lot flexibility from the brain, as the environment changes constantly [4].

### 3.1.4.2 Spinal Cord

The spinal cord (medulla spinalis) is a part of the central nervous system. Despite making up only 2% of the volume of the whole CNS - it plays a major role and its functions are crucial. The spinal cord looks like a slender cylindrical structure with approximately 2 cm diameter, it consists of gray and white matter [61, 62, 66]. The Figures 3.26 and 3.28 show a cross section of the segment of the spinal cord. It is easy to notice a butterfly-shaped area consisting of gray matter surrounding the small central spinal canal [43, 66].

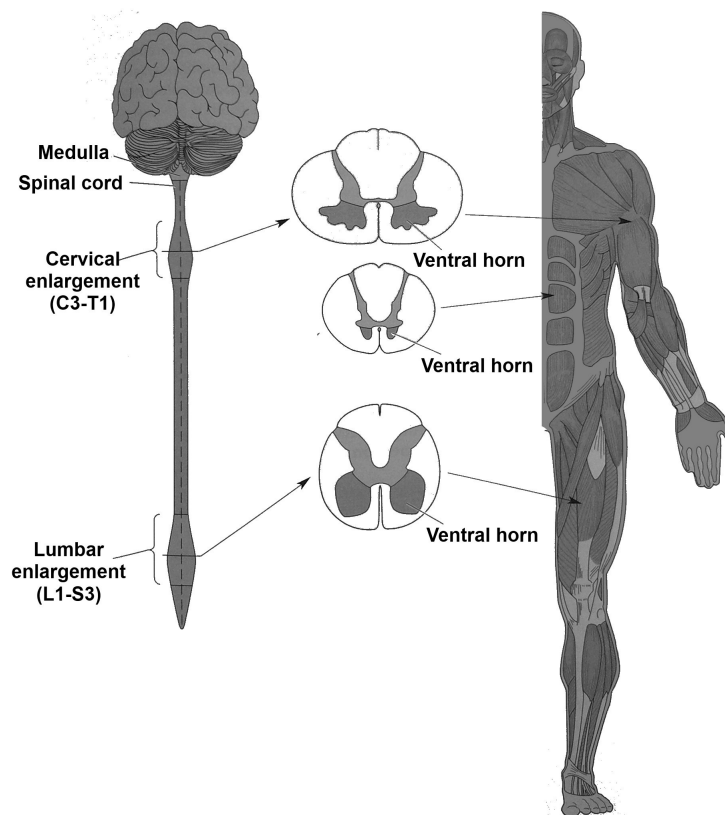
Motor neurons producing muscle movements are found in the ventral wings, where the neurons, which receive pain or sensory input - are located in the dorsal wings. The gray matter is being surrounded by the white matter. The white



**Figure 3.26:** Sample segment of the spinal cord cross section [66].

### 3.1 The Nervous System

matter consists of the fibre tracts that both travel locally within a section of the spinal cord and run back and forth in the brain [43, 48, 66]. The spinal cord is responsible for inter alia sensory input to the brain and motor commands coming from it and its responsibility is mostly related with motor activity. The commands are being send to the muscles and internal organs by the motor neurons. The spinal cord is a kind of link between the body and the brain [43]. The distribution of the motor neurons int he spinal cord has been shown in the Figure 3.27 [13].



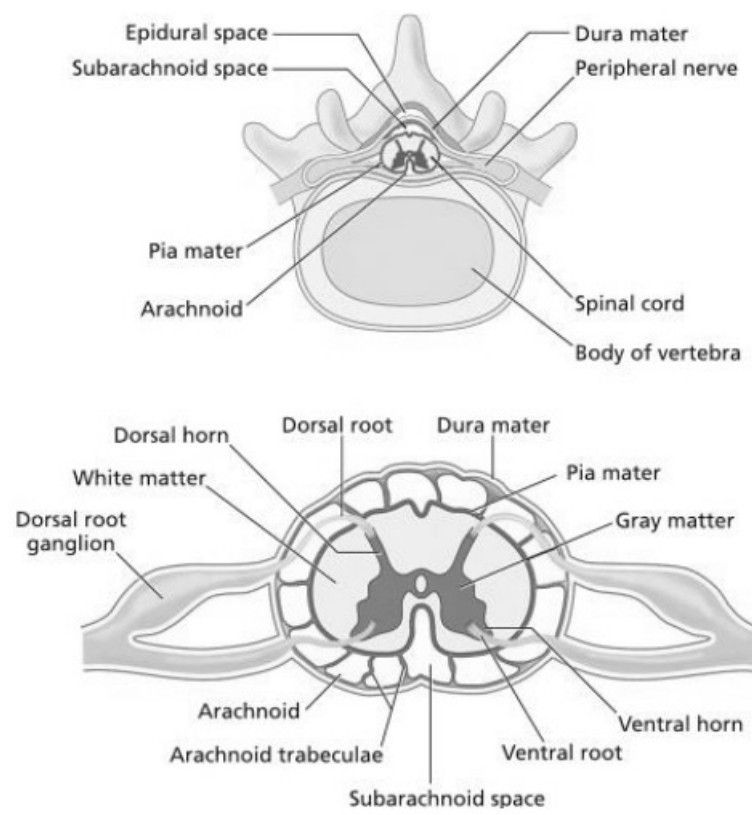
**Figure 3.27:** The motor neurons distributed in the spinal cord [13].

Shown in Figure 3.29 is the spinal cord with its main regions - thoracic, lumbar, cervical, coccygeal and sacral. The spinal cord can measure up to 45 cm and it consists of 31 segments in the following regions: cervical, thoracic, lumbar, sacral and coccygeal. The cervical region consists of 8 segments, thoracic - 12 segments, lumbar and sacral - both of 5 segments and coccygeal is made up of only 1 segment [43].



### 3.1 The Nervous System

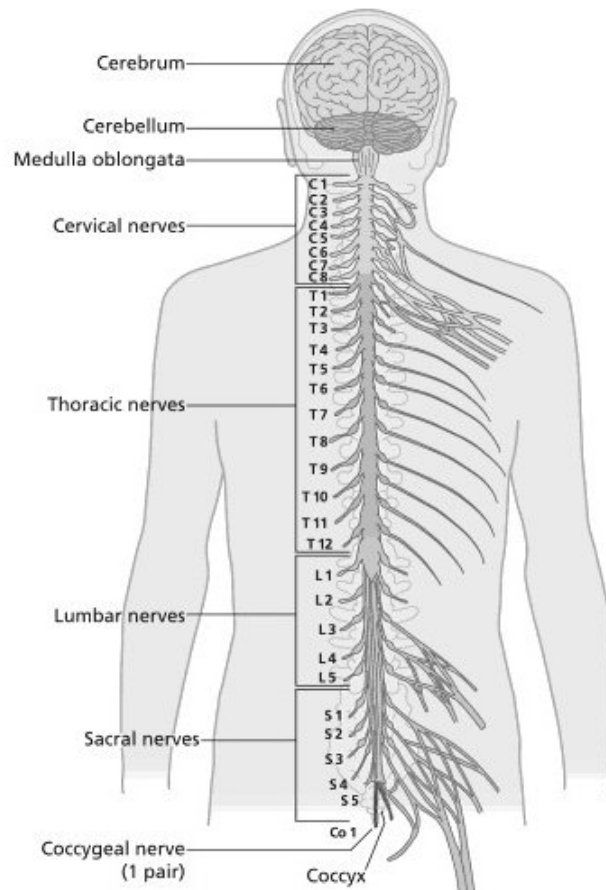
---



**Figure 3.28:** Cross section of the spinal cord [43].

### 3.1 The Nervous System

The input is being received by the spinal cord where the output is being projected via the nerve fibres in the spinal roots, nerves, rootlets and the nerves' branches. The nerve fibres are grouped in series of dorsal and ventral rootlets that, as it was mentioned above, form 31 pairs of roots. The spinal nerve is being formed as a connection of dorsal and ventral root. The spinal nerves are being named after the corresponding vertebrae. Figure 3.30 presents a scheme of spinal vertebrae with corresponding roots [48, 62].



**Figure 3.29:** The spinal cord [43].

Each spinal nerve has fibres. The fibres can be classified into four main components based in their functionality. They may be general somatic afferent, general visceral afferent, general somatic efferent or general visceral efferent. Body-based distributed components are classified as general. Sensory fibres

belong to the group of afferent components and the motor fibres are efferent [4, 48, 62].

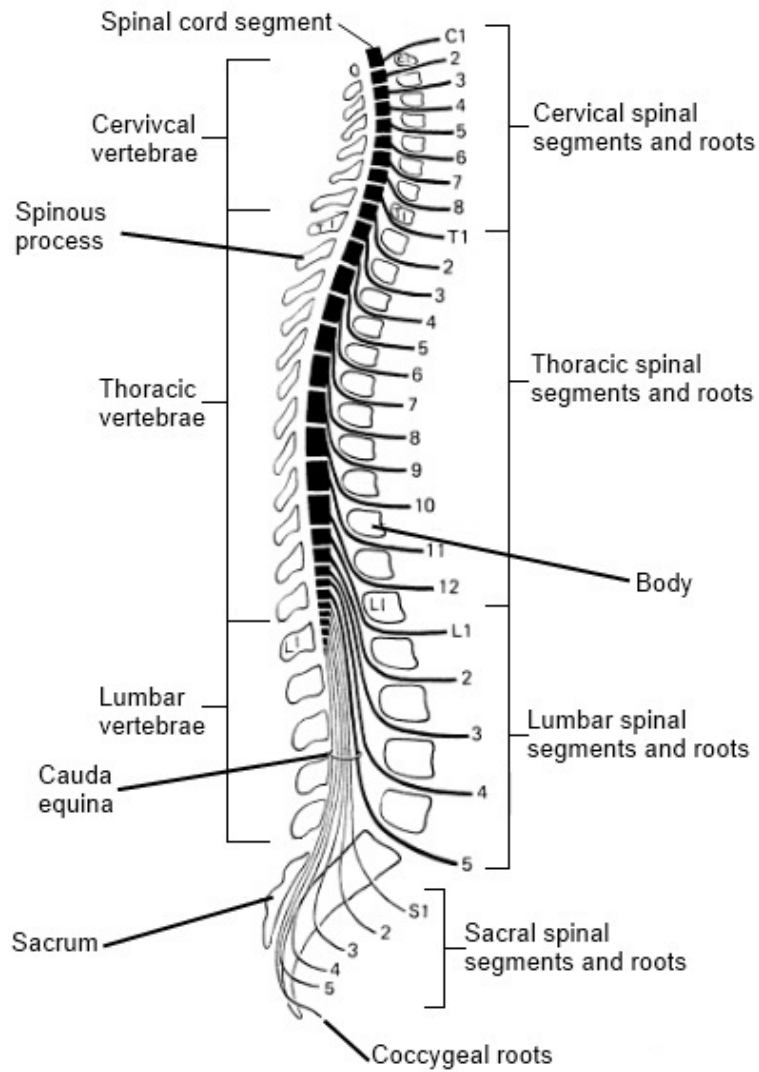
The spinal cord despite being a part of the central nervous system is a link between the brain and the peripheral nervous system. It is also very hard to estimate for sure where it belongs, whether it is the part of only the central nervous system. The spinal nerves are located in the peripheral nervous system, albeit they are a part of the spinal cord. The dorsal root ganglion has the cell bodies of which the sensory nerves consist and the sensory nerves are a part of the peripheral nervous system. It is also being considered that the dorsal root and rootlets may be a part of the PNS [67].

### 3.1.5 Pyramidal Nerves

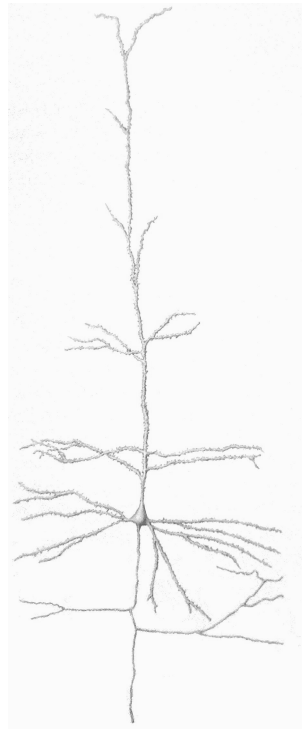
Pyramidal neurons make the pathways from the brain to the muscles. They are strongly associated with the motor activity of the human body [44, 119]. They have a very long axon and a pyramidal shape of the cell body with the two sets of dendrites. They are responsible for the transmission of the information from the cortex to the rest of the brain and spinal cord. A particular sort of a pyramidal neuron is a Purkinje cell - with strongly branched dendrites in a shape of a fan. It is responsible for the transport of the data from the cerebellum to the spinal cord and other parts of the brain [4, 47]. A pyramidal neuron was presented in Figure 3.31 [13].

Pyramidal neurons have very small, pyramidal-shaped bodies [68]. The extra-pyramidal tracts are very complex and consists of all motor tracts leading from brain to the spinal cord. The extra-pyramidal tracts play a very important role in producing larger, more complex and automatic movements or emotional expressions. Set of commands that control muscle activity that goes between extra-pyramidal pathways is called a motor program. The EEG is often a result of collective, electrical behaviour of the pyramidal nerve cells. Numerous (hundreds of thousands) small dipoles correspond to the pyramidal nerve cells [69]. Figure 3.32 shows an extra-pyramidal motor control pathway [48].

Figure 3.33 shows how the action potential propagates forward to the axon collaterals to the dendrites of a pyramidal cell [12]. Action potential is an elec-



**Figure 3.30:** Topographic relations of the spinal cord segments [62].



**Figure 3.31:** Sample Pyramidal Neuron [13].

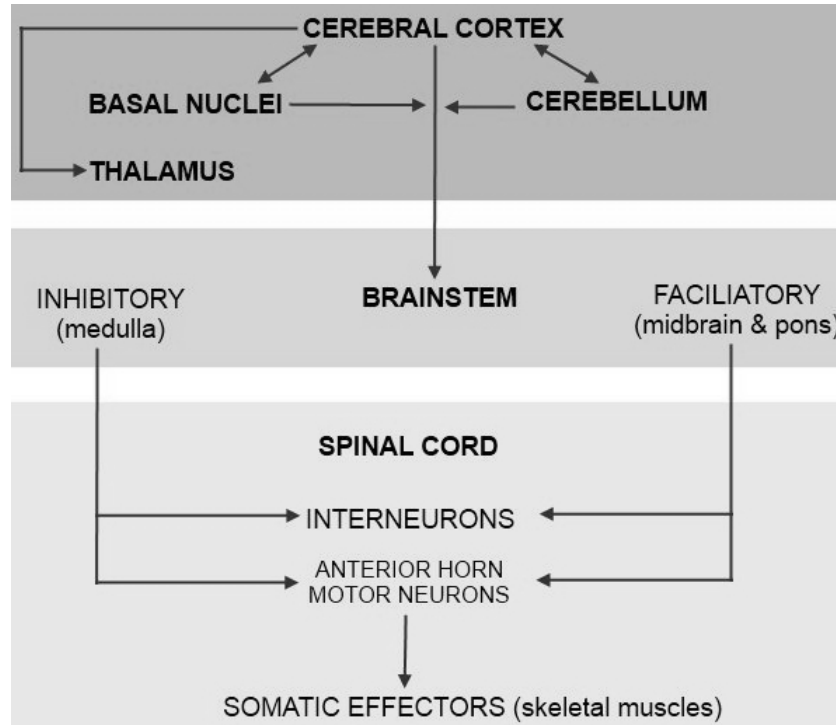


Figure 3.32: Motor control - concept [48].

trical signal similar to signals present in electronic devices. Electrically charged particles are known as ions. Ions move across the membrane of the neuron. Action potential releases neurotransmitter in pre-synaptic neurons. Chemical neuro-transmission links action potential in one neuron with a synaptic potential in another nerve cell [70].

One of the main features of the pyramidal neurons is their efficiency in transmitting the data compared to other nerve cells. As an example – one single, but strongly activated pyramidal cell is able to have a larger effect than several dozens of other presynaptic neurons [12, 61]. Figure 3.34 shows the distribution of axon terminals in the hippocampus, which has an influence on their effectiveness [69, 71].

Presented in Figure 3.35 is a cortical macrocolumn with a diameter of 3 mm. Such macrocolumn can contain as much as  $10^6$  pyramidal nerve cells, where each pyramidal neuron can have between  $10^4$  and  $10^5$  synapses [69, 72].

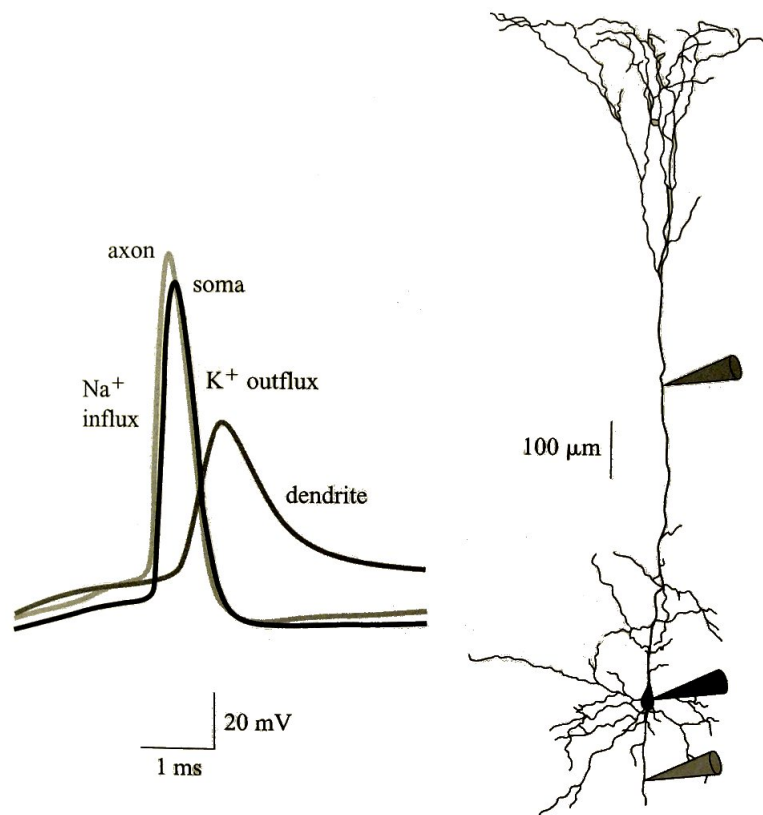
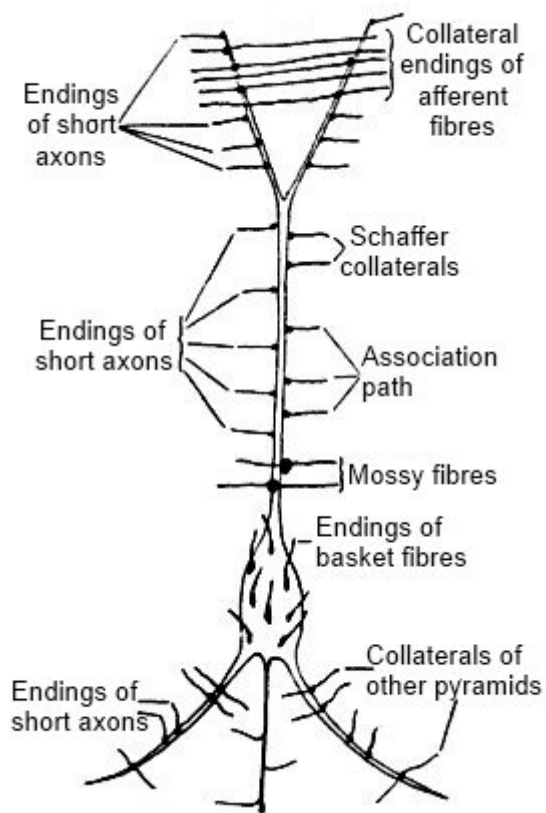
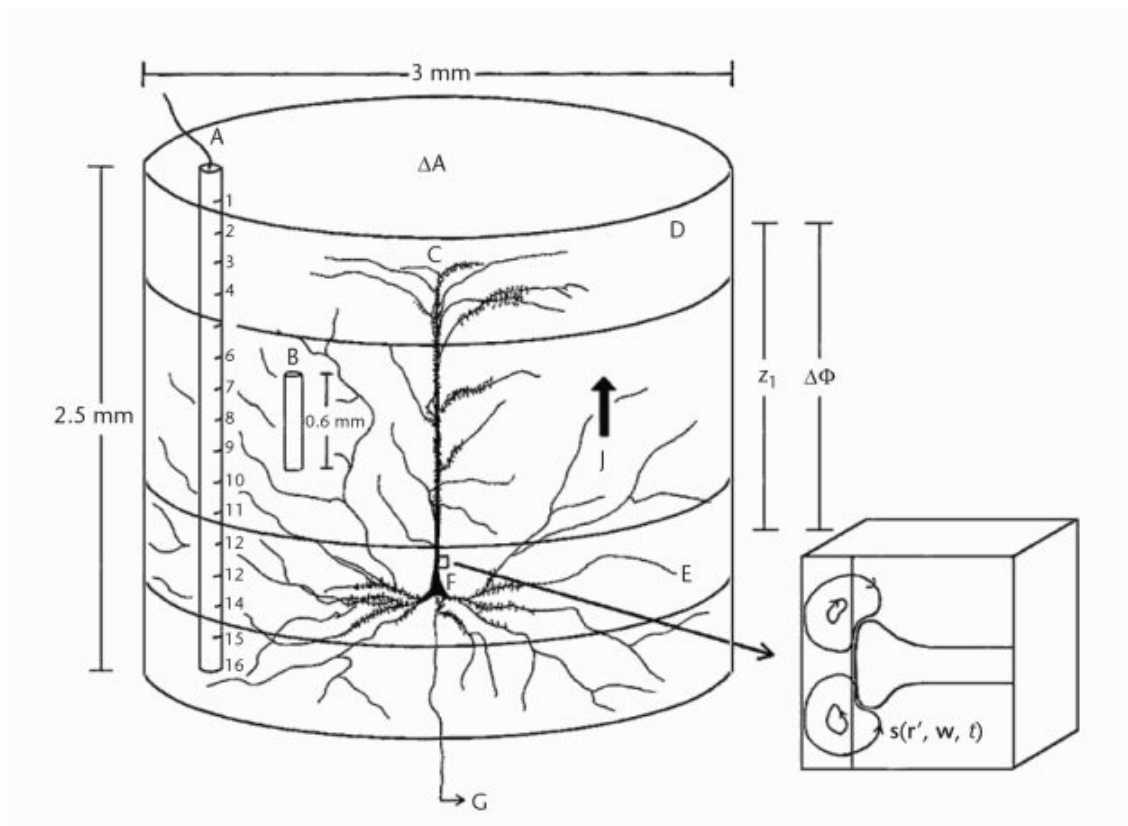


Figure 3.33: Action potential in a pyramidal neuron [12].



**Figure 3.34:** Distribution of the axon terminals in the pyramidal cell of hippocampus [71].





**Figure 3.35:** Axon branches in the pyramidal neuron [72].

## 3.2 Electrical Activity of Brain - Measurement Methods

---

**Table 3.1:** Non-invasive brain imaging methods [73].

Method	Physical Principle
Computerised tomography (CT)	Absorption of X-rays
Positron emission tomography (PET)	Emission/detection of positrons
Magnetic resonance imaging (MRI)	Nuclear magnetic resonance (NMR)
Optical imaging	Light absorption, scattering, fluorescence
Electroencephalography (EEG)	Electrical potentials
Magnetoencephalography (MEG)	Magnetic fields
Electrical impedance tomography (EIT)	Changes in electrical impedance
Functional transcranial Doppler sonography (fTCD)	Doppler effect in ultrasound

## 3.2 Electrical Activity of Brain - Measurement Methods

The human brain is always electrically active, which means – it works all the time, also while asleep [4, 48]. It is possible to divide four main techniques of measuring electrical activity of brain – electroencephalography (EEG), magnetoencephalography (MEG), event-related potentials (ERP) and the last one – single-cell recording [4]. It is also worth to mention other non-invasive methods used for purposes of brain imaging, and these were presented in the Table 3.1 [73].

### 3.2.1 Electroencephalography

The way in which the information is being transmitted in the Nervous System is related to the electrical activity of the brain. This activity enables the neurons to receive or send the information to the environment and as a result - produce movement. The EEG recording was discovered in the early 1930's by Hans Berger,

### 3.2 Electrical Activity of Brain - Measurement Methods

---

who was the first one to discover the possibility of recording the brain waves activity from the electrodes placed on scalp [4, 12, 73]. Hans Berger has obtained his first electroencephalogram measuring activity of his son's brain [12, 15]. This recording was presented in Figure 3.36 [74].



**Figure 3.36:** First EEG signal recorded by Hans Berger in 1929 [74].

The electroencephalogram (EEG) enables to get to know the activity of the cortex in the human brain. The first EEG has its roots in Richard's Caton creation. This English physiologist built in 1875 a device, which was highly sensitive to voltage. The whole process was thoroughly described later by the above mentioned Hans Berger [13]. The electroencephalogram is recorded from the electrodes placed on the scalp, where the electronic amplifier is able to detect the electrical activity of the brain[15]. The signal is being gathered from multiple electrodes placed on the scalp [48, 75].

The voltage registered by the electroencephalograph is very low and mostly consists of the currents flowing during the synaptic excitation of the dendrites being part of numerous pyramidal neurons. The pyramidal neurons are located in the cerebral cortex [13, 48]. As the EEG signal is very low, the recording device has to be very sensitive [76]. The EEG signal consists of signals coming from summed electrical activity of neurons with a slight contribution of glial cells participation [73]. It is important to mention presence of neural oscillations. These are rhythmic or repetitive neural activity in the CNS. Neural tissue is able to generate oscillatory activity in multiple ways. In individual neurons the oscillations may appear either as oscillations in membrane potential or as rhythmic patterns of action potentials. Synchronised activity of large numbers of neurons may result in rise to macroscopic oscillators – these can be observed in EEG signal. An example of macroscopic neural oscillation is alpha activity. Oscillators display repeated variations in the level of some output, which results in sine wave of position versus time. Oscillations of the electrical activity recorded by EEG

## 3.2 Electrical Activity of Brain - Measurement Methods

---

and MEG may reflect possible activities of synchronously oscillating neurons – particularly cortical pyramidal neurons. Oscillations at standard EEG/MEG frequencies such as delta (0.5 - 3.5 Hz), theta (3.5 - 7 Hz), alpha (8 - 13 Hz), beta (15 - 25 Hz), and gamma (30 - 70 Hz), arise spontaneously in simulations of networks of relaxation oscillator neurons [77].

EEG voltage is very low and the signal comes from the cerebral cortex, which is covered with several layers of non-neural tissues – such as skin, skull – it has to overcome it, which may influence its quality. This is reason for the role of a lot of neurons in generating the signal strong enough to be caught by the EEG electrodes [13]. If the electrodes were implanted directly to the brain, the interference coming from the brain would be removed, unfortunately due to the invasive character of this process – it is not used in the research [15]. Figure 3.37 shows the scheme of recording the EEG signals. Part a) of this illustration shows two electrodes placed on the scalp, whereas part b) presented microcurrent coming from synaptic and action potentials in cerebral cortex. Part c) shows a sample epoch of alpha-waves with its power spectrum [72].

Figure 3.38 shows the process of large EEG signals generation. There is a multiple amount of pyramidal neurones, where the EEG electrode is placed. It is important that the pyramidal neurons receive synchronised synaptic inputs as it makes the amplitude of the electroencephalographic signal larger and easier to analyse. Usually in the case of a subject being in good, healthy condition, there is a large amount of pyramidal neurons, which are able to receive synchronised synaptic inputs. It is also important to mention that the amplitude of bio-signals, such as EEG, depends on synchronisation of the neurons generating this signal [13, 78].

The EEG plots voltage against time, where the voltage is responsible for the amplitude determination. A very strong effect on the quality of the signal has 'layers' through which the signal has to go, and these are the following: leptomeninges, cerebrospinal fluid, dura mater, bone, galea and scalp. As a result – the amplitudes of the scalp are reduced and amount to the values between 10 and 100  $\mu\text{V}$  (adult subjects) [73, 79]. Properly functioning cortex has a very large population of neurons working simultaneously in synchronisation [80].

### 3.2 Electrical Activity of Brain - Measurement Methods

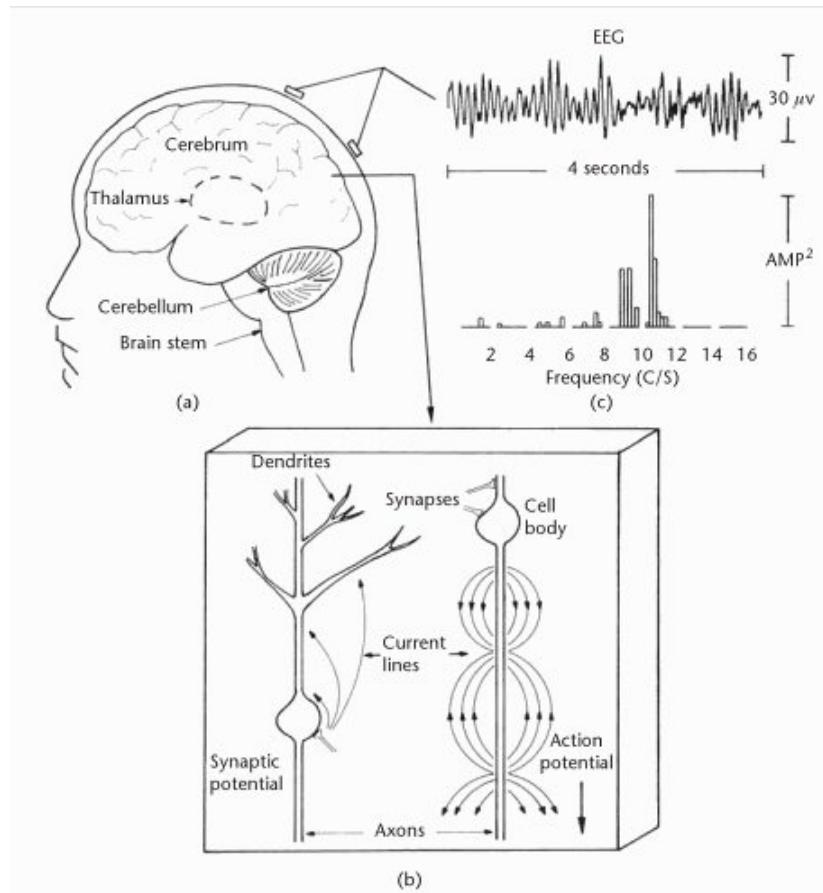
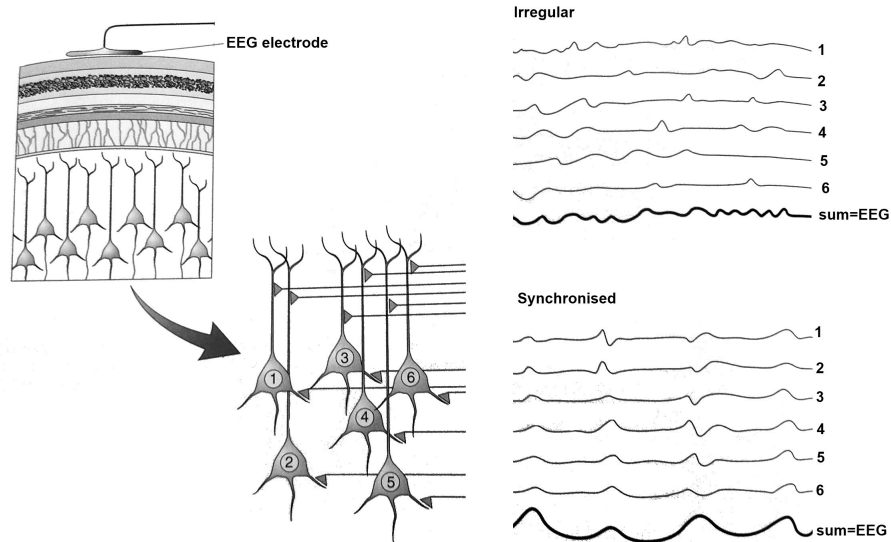


Figure 3.37: Scheme of EEG-signal recording [72].

## 3.2 Electrical Activity of Brain - Measurement Methods



**Figure 3.38:** EEG signals generation [13].

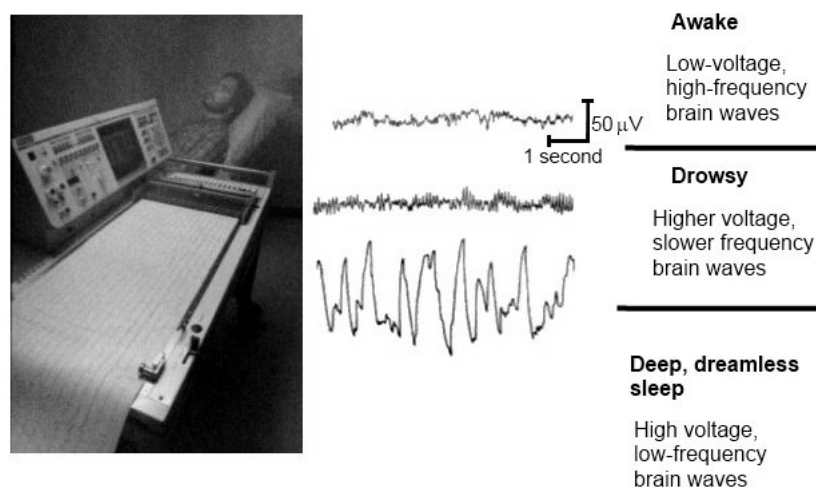
Figure 3.39 shows the process of the electroencephalograph recording with the sample patterns of activity, which changes while the tested subject changes his state from waking to sleeping. The EEG device records the signal – a result of electrical activity of brain – from the electrodes placed on scalp [15, 48]. Electrical ink pen writes on rapidly moving paper in this case (Fig. 3.39). This process provides both voltage and time measures [15].

The EEG technology may also be used to confirm death or brain-death [47, 80]. It can also be applied (similar to MEG) to estimate the mental state of a tested subject [80].

Polygraphs work on the basis of assumption that the true answer causes little or no change in the level of sympathetic excitation in the body. When a subject is lying – unavoidable rise in the level of anxiety can be observed. These changes can be measured in inter alia palmar conductance, blood pressure, respiration rate and muscle tension [80].

The next part of this work will describe the most important rhythms of the EEG. It is crucial, as the intensities of the EEG recorded from the scalp may vary from 0 to (max)  $100 \mu\text{V}$  and their frequencies may range from once to over fifty times per second [11].

## 3.2 Electrical Activity of Brain - Measurement Methods



**Figure 3.39:** Electroencephalograph recording electrical activity of brain [15].

### 3.2.1.1 Description of the Main EEG Rhythms

The brain activity of a living person is never calm or silent and is able to reflect different states of awareness, what is shown in Figure 3.40 [4]. EEG rhythms are frequently related to the particular states of behaviour of the person, who generates them. They may vary while we are active (and the level of our activeness can also differentiate the amplitude of the EEG signal) or not. They have also different form, while we are asleep (and vary depending on the sleeping phase) [13].

A brainwave can be described as a transient difference in electrical potential between any two points on the scalp or between electrode placed on the scalp and electrode placed in the different location on head – such as on ear lobe or nose [82].

When an examined subject has opened its eyes and is awake, alert and attentive – the signal registered from the frontal and cerebral regions is fast and low-voltage (beta-waves). Slower brainwaves describe sleepy or drowsy states, where the quicker the rhythms is – the more alert the individual is, however this not always apply [48].

In the Figure 3.41 main EEG rhythms in a form of time function have been illustrated [81].

## 3.2 Electrical Activity of Brain - Measurement Methods

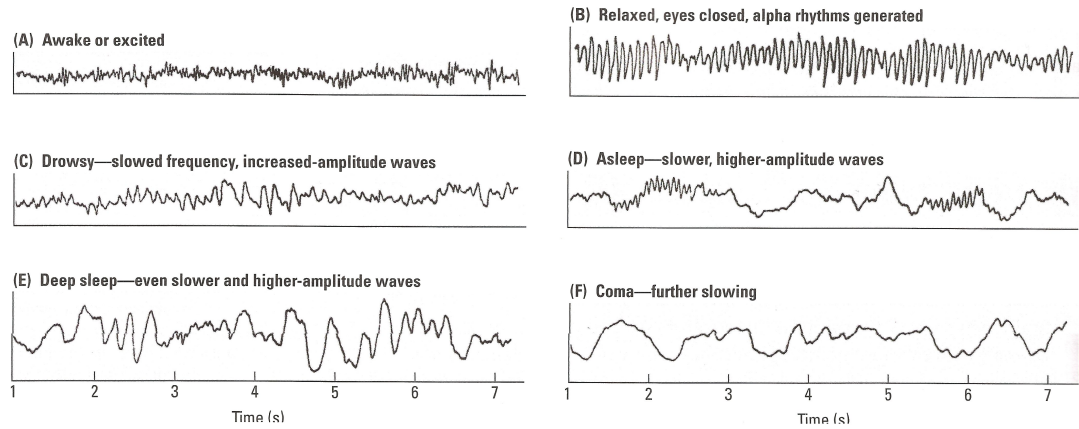


Figure 3.40: Sample EEG characteristics [4].

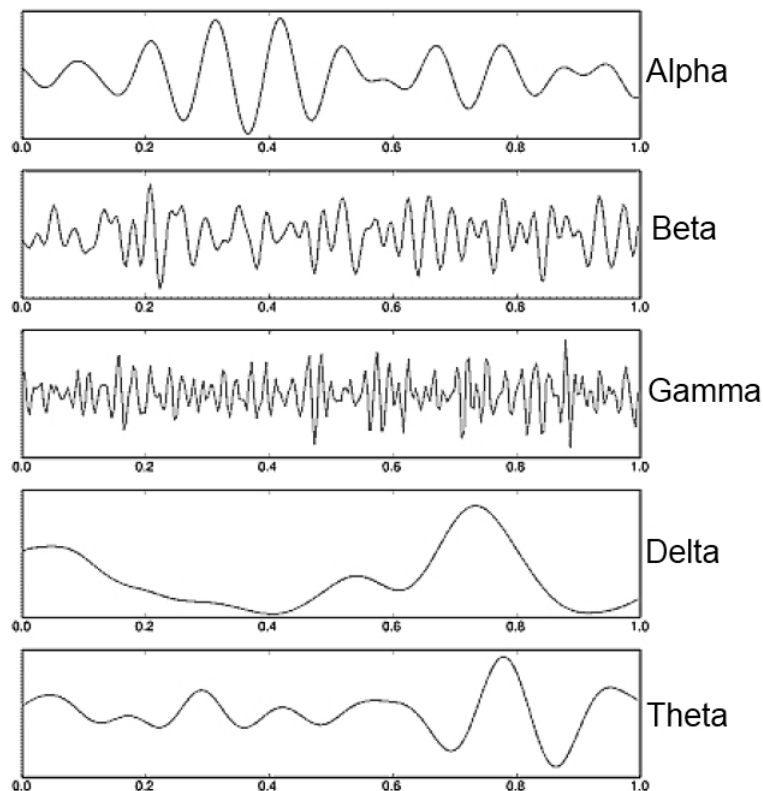


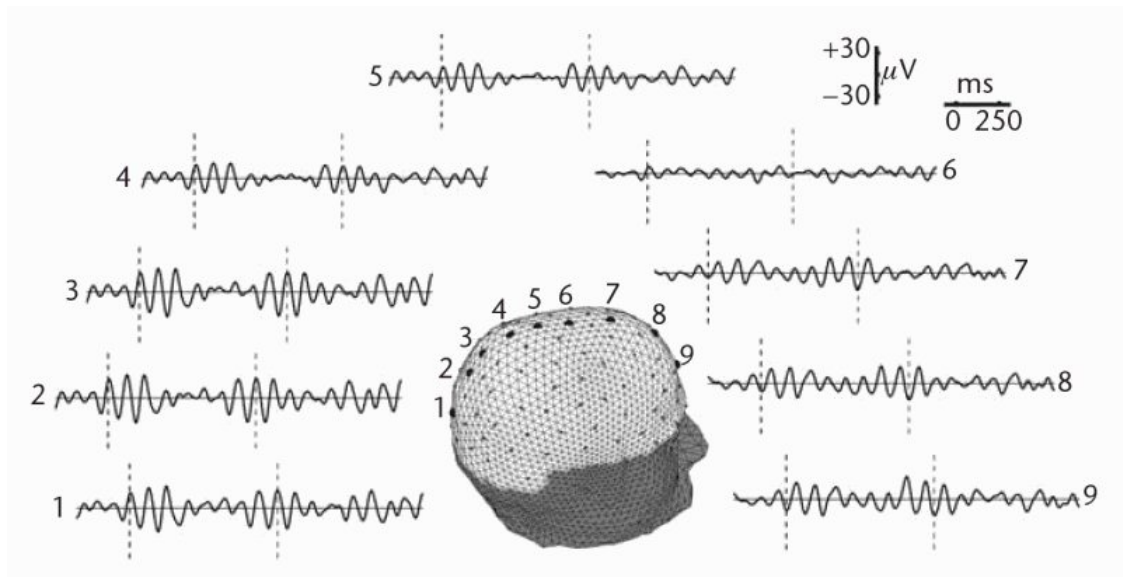
Figure 3.41: Main EEG rhythms as a time function [81].



### 3.2 Electrical Activity of Brain - Measurement Methods

The categorisation of the rhythms depends on their frequency, named after letters in Greek alphabet [13]. The first rhythm observed by Berger were Alpha-waves (called Alpha, because they were first observed). These waves have large amplitude of 10 cycles per second what corresponds to  $\sim 10$  Hz. The faster waves, with smaller amplitude – were the Beta-waves – observed shortly after [12].

Alpha rhythms are very regular, with a frequency of approximately 11 cycles per second, however it is possible to differentiate both – slow and fast  $\alpha$ -waves [4]. They are about 8-13 Hz and are linked with quiet waking state [13]. The alpha-waves are linked with 'relaxed' state [48, 79] or when the eyes are closed. The alpha-waves amplitude may vary depending on tested subject [76, 79]. This is a result of beta-waves domination as a result of undertaking an activity [76]. Figure 3.42 illustrates the recording of the alpha waves registered from the nine electrodes places along the mid-line of the scalp, when the subject was in a resting state with closed eyes [72].



**Figure 3.42:** Alpha-rhythms potential waveforms recorded recorded along the mid-line [72].

The alpha rhythms have usually rounded or sinusoidal wave forms, although there is also a part of human population with sharp-shaped alpha-waves, where the negative component of the rhythm is sharp and the positive – rounded. This

### 3.2 Electrical Activity of Brain - Measurement Methods

---

may result in mistaking these waves from the mu-rhythms [79].  $\mu$ -waves are sometimes categorised as a separate waves, where some of the sources treat them as a variant of the  $\alpha$ -waves.

Fast, with a very high frequency – greater than 14 Hz are beta rhythms [13]. They dominate when the brain of an individual is occupied with sensory stimulation or mental activities [48]. The rhythms stand for frequency band over 13 Hz per second although its amplitude rarely exceeds 30  $\mu$ V [79], usually it is between 2 and 20  $\mu$ V [76]. It can also appear after the use of barbiturates. It can be recorded from the front-central area [79]. The label 'EXCITED' in Figure 3.45 shows the amplitude of the beta-rhythms [76].

Theta rhythms – with the frequency of only 4-7 Hz – occur in some sleep states [13, 82]. Theta waves are often called 'drowsy waves' [48]. This rhythm has been firstly introduced by the two researchers – Walter & Dovey in 1944. The term results by its assumed thalamic origin [79]. The amplitude of theta waves is relatively high – 20 to 100  $\mu$ V. It occurs more often in the recording of children brain activity and as a result is irrelevant to my study. It occurs in opposite, strong states of pleasure or displeasure [76].

Very slow, with a low frequency – less than 4 Hz are the Delta Rhythms, they are present in the states of very deep sleep [13, 48, 82]. These waves are very slow – as mentioned above – with the frequency of 0.5 to 3.5 cycles per second, although they have a very large amplitude in range of 20 up to 200  $\mu$ V. Normally they appear only in state of sleep. Sample delta activity is presented in the inter alia Fig. 3.45 – in its bottom part – state of sleep [76]. Sometimes they may also appear during continuous attention tasks.

The rhythms with the highest frequency are the gamma waves – 30-80 Hz [13, 82]. They were firstly reported in 1981 by Galambos, Makeig and Talmachoff. They occur as a result of visual or sound stimuli such as clicks or flashes of light. Its resting frequency is 40 Hz. Very characteristic for these waves is the change of amplitude level – from 5  $\mu$ V in the prestimulus state to 10  $\mu$ V after the stimulation [76].

It is also possible to notice Lambda waves, which occur over the occipital region of the head during visual stimulation [79]. They were discovered by Gastaut in 1951 and Evans in 1952. They can be recorded from electrodes placed on the

## 3.2 Electrical Activity of Brain - Measurement Methods

---

area of visual cortex. They have a triangular shape and amplitude between 20 and 50  $\mu\text{V}$ . They appear as a visual response and last between 150 and 200 ms [76].

It is crucial in this work to describe the mu-waves, due to their special features and use in my PhD-project. In 1950 two researchers Altschuler and Ramachandran conducted experiments involving non-invasive EEG scans. The group of volunteers had to perform simple actions such as – opening and closing their hand. This activity showed in in motor cortex waves called 'mu-waves'. Their research showed that a motor action causes appearance of the mu-waves [120]. The mu-waves may have the same frequency range as the mentioned above alpha-waves, but they have completely different topography and reactivity. As it was mentioned above – sometimes the alpha waves strongly remind the mu-waves, as for some part of the population they tend to have sharp-sized negative components, where the positive components stay rounded [76, 79]. Some of the sources state that  $\mu$ -waves do not exist and cannot be classified as a separate form of brain-waves, but are only a variant of  $\alpha$ -waves.

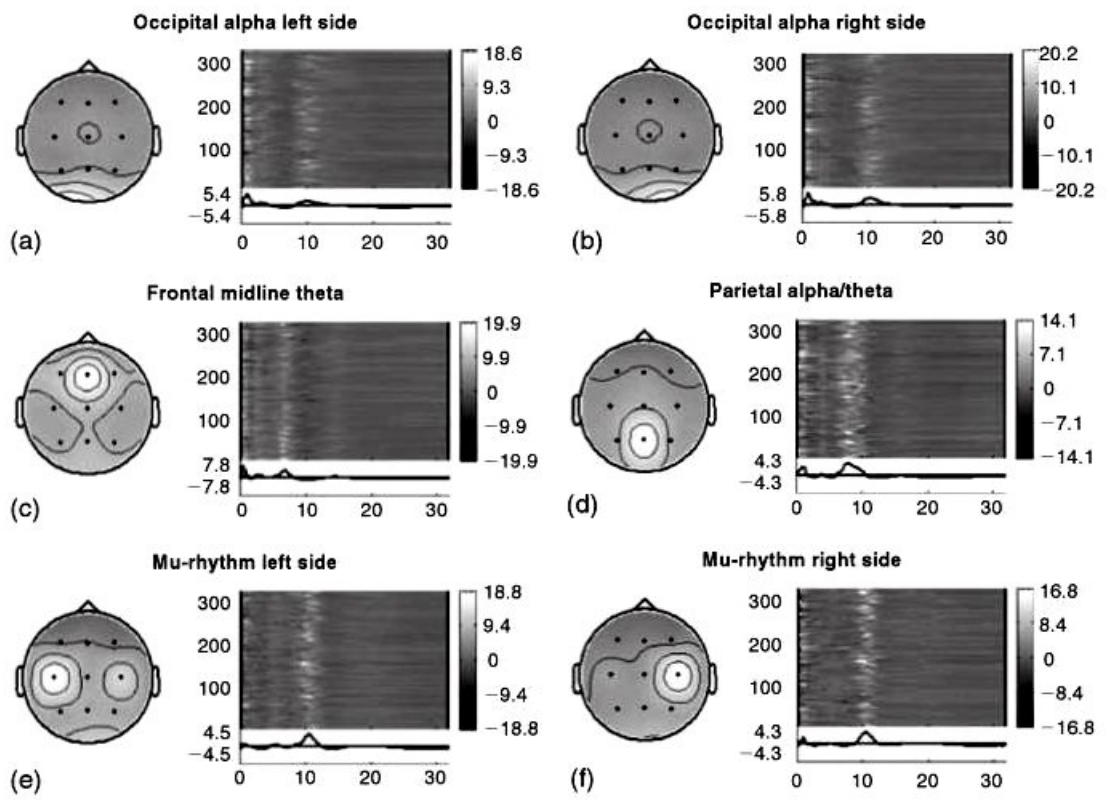
An action such as opening or closing eyes – despite being a motor activity – does not diminish the intensity of the mu-waves. They are always represented by movements of hands, arms and legs. They also appear by thinking of those activities or by even seeing someone doing them [80].

An example of normal (generated by a healthy subject) EEG is presented in the Figure 3.44. The tested subject is calm, quiet and awake, the first part shows the alpha rhythms. In the middle of the recording the subject opened his eyes, what resulted in occurring of the blink artifacts [13].

Figure 3.43 presents the Independent Component Analysis (ICA) on the amplitude spectra of the measured EEG signal. The ICA is based on analysing various signal components, which correspond to the particular brain-waves [69]. ICA and its possible implementation for BCI purposes will be in more detail described in Chapter – 'Signal Processing – Overview'(4), Section – 'Signal Processing Methodology'(4.1), Subsection – 'Independent Component Analysis'(4.1.6).

It is impossible to guess during the analysis of the electroencephalographic signals the thoughts of the tested person, but it is possible to notice the level of

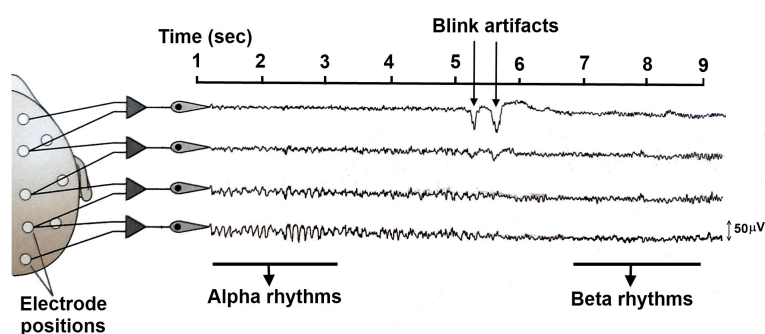
## 3.2 Electrical Activity of Brain - Measurement Methods



**Figure 3.43:** Sample analysis of the brain activity based on ICA (Independent Component Analysis) [69].

## 3.2 Electrical Activity of Brain - Measurement Methods

this person's waking [13, 76]. It is also possible to notice the excitement of the subject.



**Figure 3.44:** Sample EEG – alpha- and beta- rhythms [13].

Figure 3.45 shows sample EEG signals recording in various states of the subject's excitement level and its sleep [76].

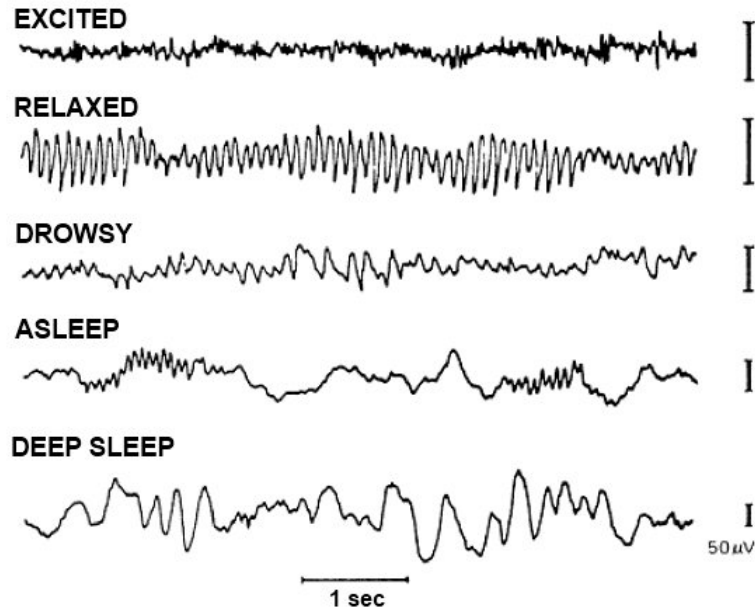
EEG patterns are very complex and hard to process – it is possible to assume that each pattern is a combination of other patterns. Table 3.2 shows a short summary of the main EEG brain-waves [80]. The brain-waves pattern is related to particular behavioural states. These states may be referred as either synchronised or desynchronised. Brain-waves are synchronised when high-amplitude oscillations with slow frequency imply. In case lower amplitude with faster rhythms appears – it is called desynchronisation [83].

To sum it all up – the rhythms with high-frequency and low amplitude are conjoined with both alertness and waking or dreaming stages of sleep, where the signals with the low frequency, but high amplitude show us the non-dreaming sleep states or coma (as an example of a pathological state) [13, 48]. Presented in Figure 3.46 are the frequency bands in the EEG spectrum. The frequencies are not strictly estimated, but their classification was proved through the over 80-years long research [69].

### 3.2.1.2 Functional States of the Human Brain

It is important to mention the two main types of the brain conduct – the state of sleep or awake. The state of sleep consists of several phases, that occur

### 3.2 Electrical Activity of Brain - Measurement Methods

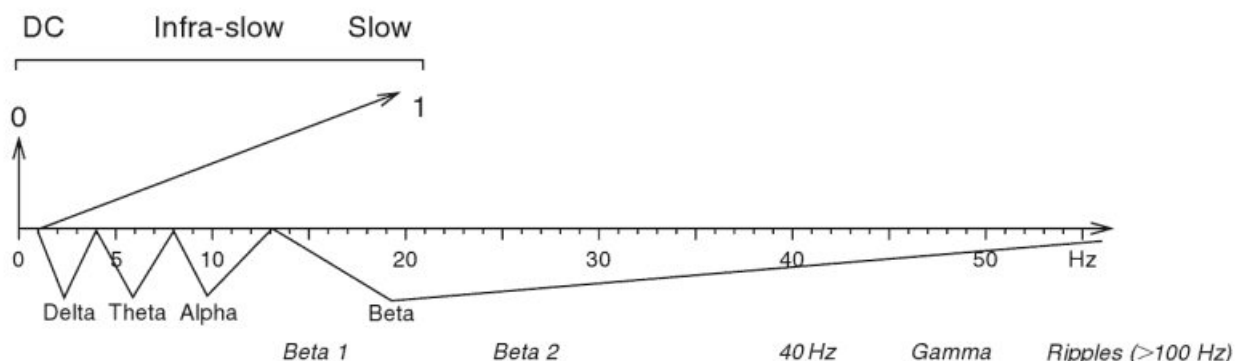


**Figure 3.45:** EEG signal recorded in various state of subject: excited, relaxed and asleep [76].

**Table 3.2:** Characteristics of the EEG brain waves [80].

Name	Frequency – Herz	Amplitude	Synchronicity	Mental State
Alpha	8-12	High	Synchronised	Relaxed wakefulness; tranquility; nonarousal; meditative
Beta	15-40	Low	Desynchronised	Mental activity of normal wakefulness; wakefulness; aroused, metabolically active; strong mental engagement
Gamma	40-90		Synchronised	Sensory integration; memory consolidation; meditation
Theta	4-7	Very high	Desynchronised	Dreaming state; creativity while awake
Delta	1.5-4	High	Desynchronised	Stage of dreamless sleep

## 3.2 Electrical Activity of Brain - Measurement Methods



**Figure 3.46:** EEG frequency bands [69].

alternately during the night. The phases can be divided into two groups – the REM sleep and the non-REM sleep. The REM sleep phase is when a body (or brain) enters the phase of rapid eye-movement sleep. This phase can look in the EEG rhythms more awake than a typical sleep state. In this phase we experience dreams. The second group – is the non-REM sleep. Our brain does not generate dreams [13].

Table 3.3 presents the functional states of the human brain. It shows, that the non-REM sleep is a phase of the most rest. During this phase the muscle tension of the body is reduced, the body feels relaxed, there is also little or no movement. The relaxed state of the brain in the non-REM sleep does not mean, that there is no rest for the body. The large amplitude of the slow EEG signal shows high synchronisation of the cortex neurons [4, 13].

Figure 3.47 shows the stages of sleep. Stage 1 non-REM sleep is a phase, where the EEG alpha waves become less regular and wane and the eyes produce small rolling movements in this phase. This is the lightest, most sensitive stage of sleep. The next stage is Stage 2, which is slightly deeper and lasts 5-15 minutes. Characteristic for this phase is occurring of the sleep spindle. The sleep Spindle is an 8-14 Hz EEG oscillation. We can also observe in the Stage 2 – a high amplitude sharp wave called K complex. In the Stage 3 we can observe slow delta rhythms with a large amplitude. There is usually neither eye nor body movement. The last stage is the Stage 4. This is the deepest phase of sleep. In this phase are present large EEG waves of less than 2 Hz. This stage lasts between 20 and 40

## 3.2 Electrical Activity of Brain - Measurement Methods

---

**Table 3.3:** Three Functional States of the Brain [13].

Behaviour	Awake	Non-REM sleep	REM sleep
EEG	Low voltage, fast	High voltage, slow	Low voltage, fast
Sensation	Vivid, externally generated	Dull or absent	Vivid, internally generated
Thought	Logical, progressive	Logical, repetitive	Vivid, illogical, bizarre
Movement	Continuous, voluntary	Occasional, involuntary	Muscle paralysis; movement commanded by the brain but not carried out
Rapid eye movement	Often	Rare	Often

minutes during the first cycle of sleep [13]. The lengths of the particular phases of sleep depend on the duration of the sleep and on its depth. The factors such as age, sex or epilepsy may also affect it [79]. To sum it all up – there are two sorts of sleep – REM and non-REM sleep. We can estimate that around 75% of our sleep is non-REM, when REM only – 25% [12, 13].

After the Stage 4 phase occurring during the first cycle, the the brain shifts to the Stage 2 for 10 to 15 minutes, which is followed by short REM sleep phase [13, 48].

The stages of the brain are not relevant to my project, but it was important to mention them, as it is crucial to see the differences in the characteristics of particular brain-waves, which provide the information not only about the state of the subject, who generated the signal, but also enable to notice the type of the rhythm.

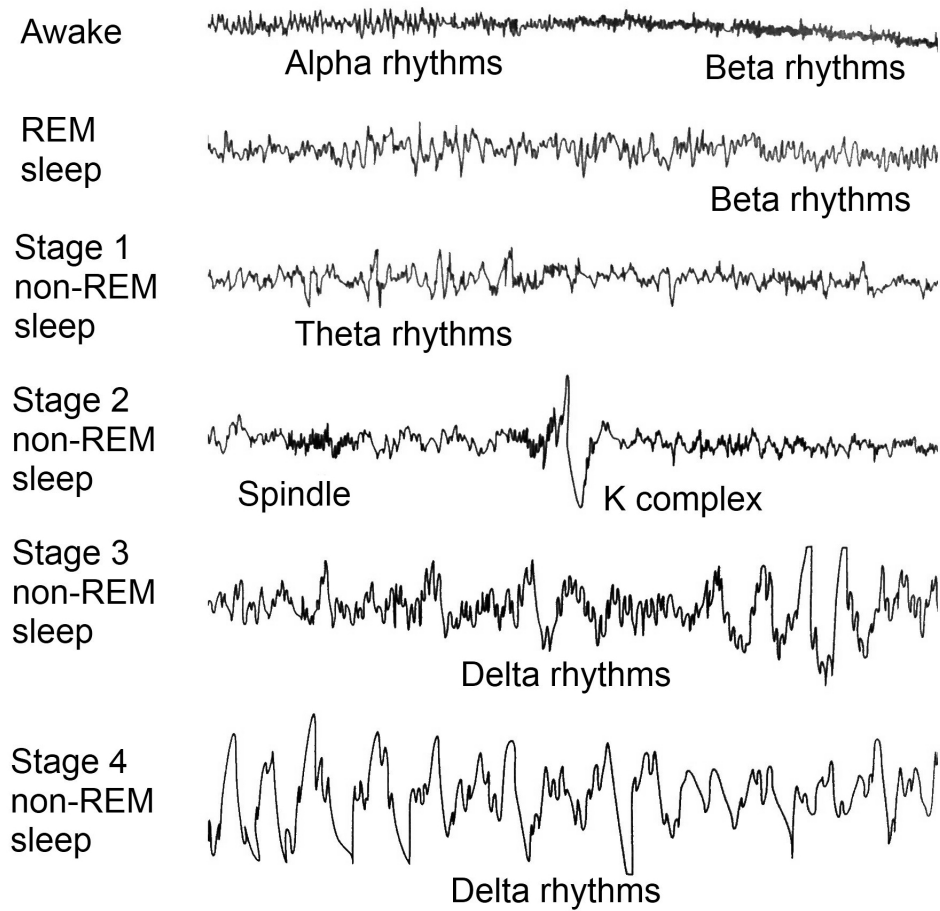
### 3.2.1.3 The Electrode Placement Systems

The process of EEG signal recording is uncomplicated and non-invasive. The electrodes are placed on the scalp in the positions according to the most popular – 10-20 system and labeled according to their position on scalp. Electrodes labeled with 'O' are over the occipital area on the head. Labels 'P', 'F' and 'T' stand



### 3.2 Electrical Activity of Brain - Measurement Methods

---



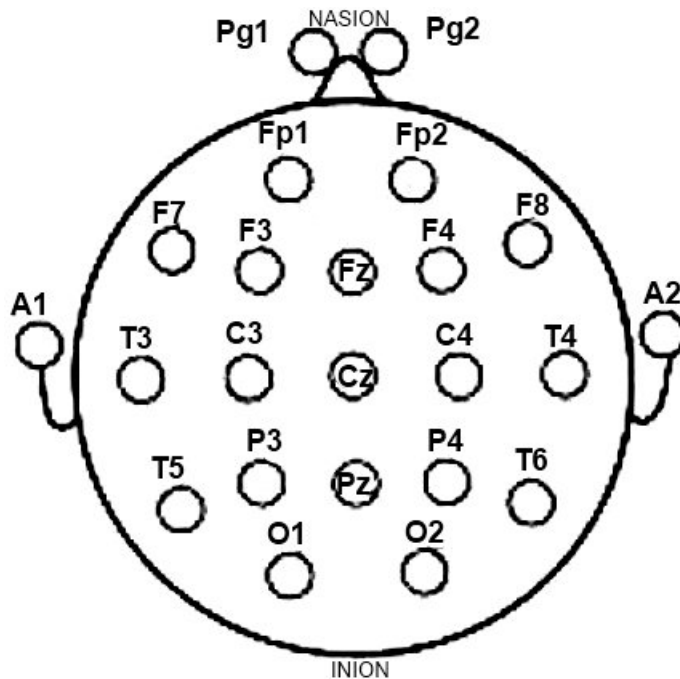
**Figure 3.47:** Sample EEG signal recorded during sleep [13].

### 3.2 Electrical Activity of Brain - Measurement Methods

for the parietal, frontal and temporal areas. 'C' is for the central location of the electrode. Next to the labels are indices, such as "z" – eg.  $O_z$ , where "z" means the distance between the nasion and inion. Nasion means bridge of nose, where inion is a bone at the back of the head over the occipital area. The odd numbers in indices refer to the left brain hemisphere and the even numbers – right. The 10% of the measurement is the distance in centimeter toward the nasion [76, 82].

As the activity of brain-neurons includes also the electric fields present also at the surface of the head, so the appropriate placement of the electrodes play a very important role [75].

Standard array of EEG electrodes consists of 21 electrodes located according to the above mentioned 10-20 system [11, 82]. Figures 3.48 and 3.49 show the appropriate placements of the electrodes according to the 10-20 system, where Fig. 3.48 illustrates the standard, basic system, and Fig. 3.49 shows an expanded version 10-20 electrode placement [11]. The electrodes are mostly placed on scalp, but it is possible to notice some of them placed on the nostrils or under eyes in order to register other signals, crucial for some conducted experiments.



**Figure 3.48:** Standard international 10-20 system [11].

### 3.2 Electrical Activity of Brain - Measurement Methods

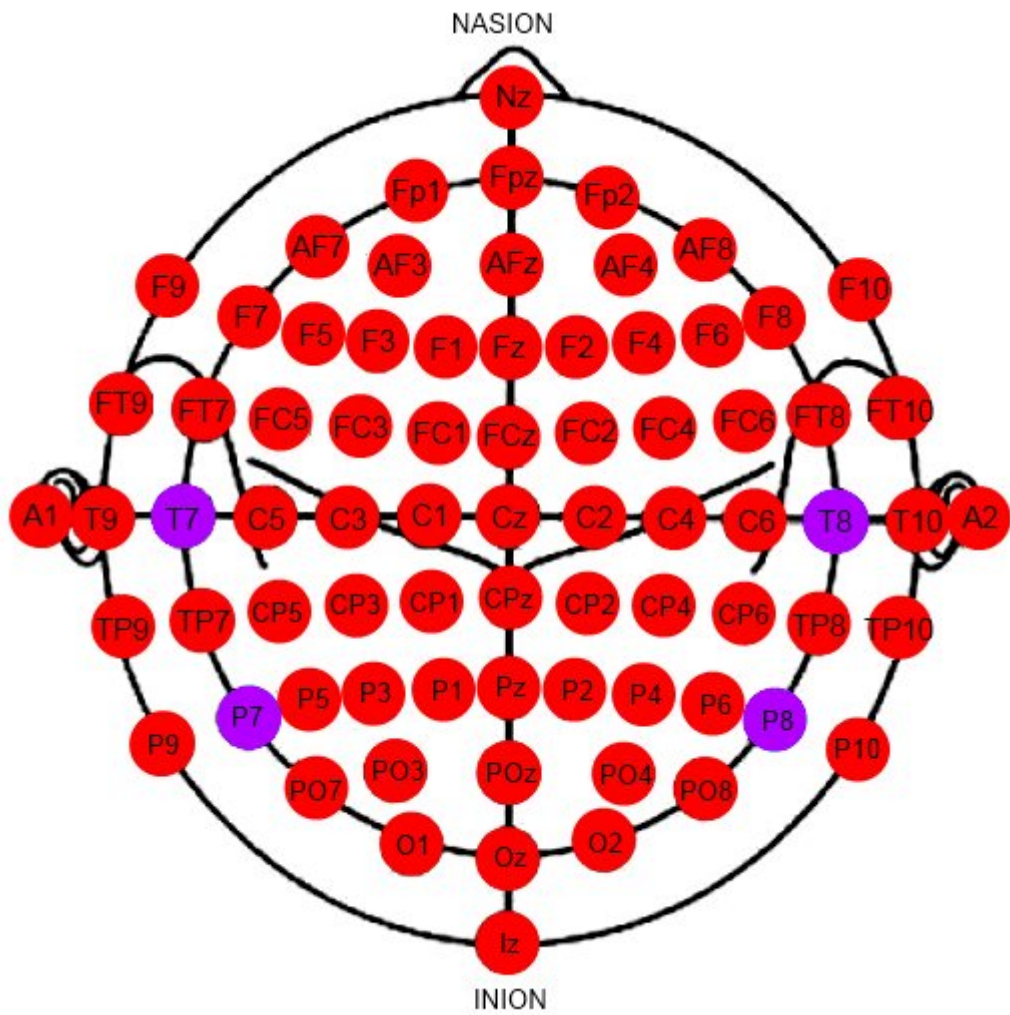
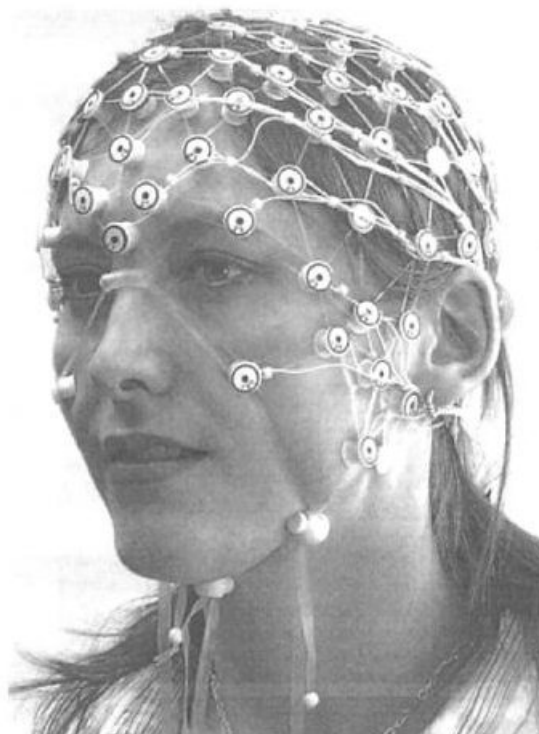


Figure 3.49: Expanded 10-20 system – known as 10-10 system [11, 84].

## 3.2 Electrical Activity of Brain - Measurement Methods

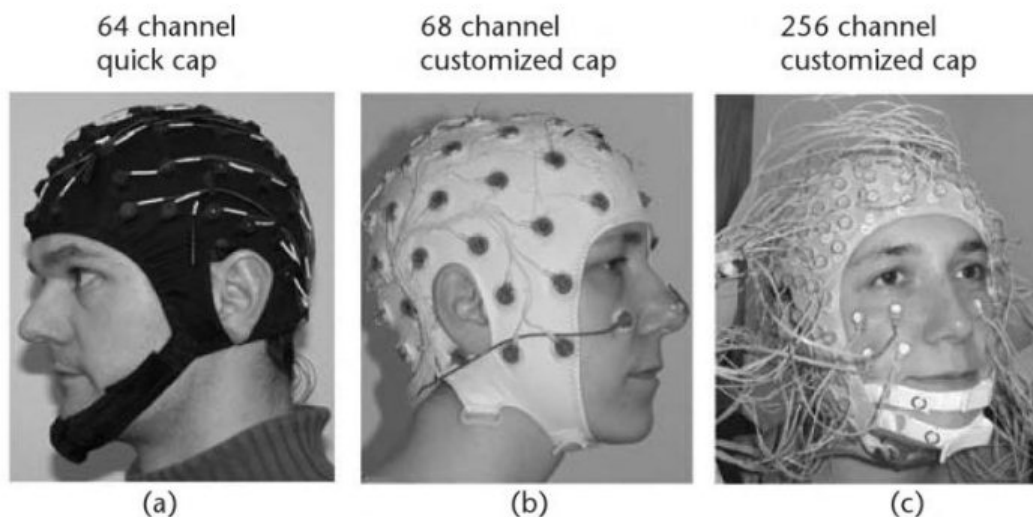
---

Figure 3.50 shows a participant with a Sensor Net of 128 electrodes measuring electroencephalographic signal the scalp. The subject has also additional electrodes placed on her cheeks and near the eyes. These electrodes measure respectively muscle and eye movements [76].



**Figure 3.50:** Participant with a Sensor Net of 128 EEG electrodes and with some additional placed on cheeks and near the eyes [76].

Except the 10-20 electrodes placement system, there is also a system called 10-10, which is more popular when it comes to the use of multi-channel caps, as presented in Fig. 3.51. Figure 3.51 shows various montages of the electrodes. Part a) of this illustration presents the commercially available 64-channel cap, based on the above mentioned 10-10 system, the part b) shows a cap with 68 electrodes, where the part c) presents a cap with as much as 256 channels. The 10-10 system was created for multi-channel caps, as the 10-20 system is limited to only 21 electrodes, although the 10-10 system has also its limits – as it can only have up to 74 electrodes. This resulted in developing the 10-5 system – with the limit of 345 electrodes locations [72].



**Figure 3.51:** Electrodes-caps and montages [72].

### 3.2.1.4 Artifacts in the EEG Signals

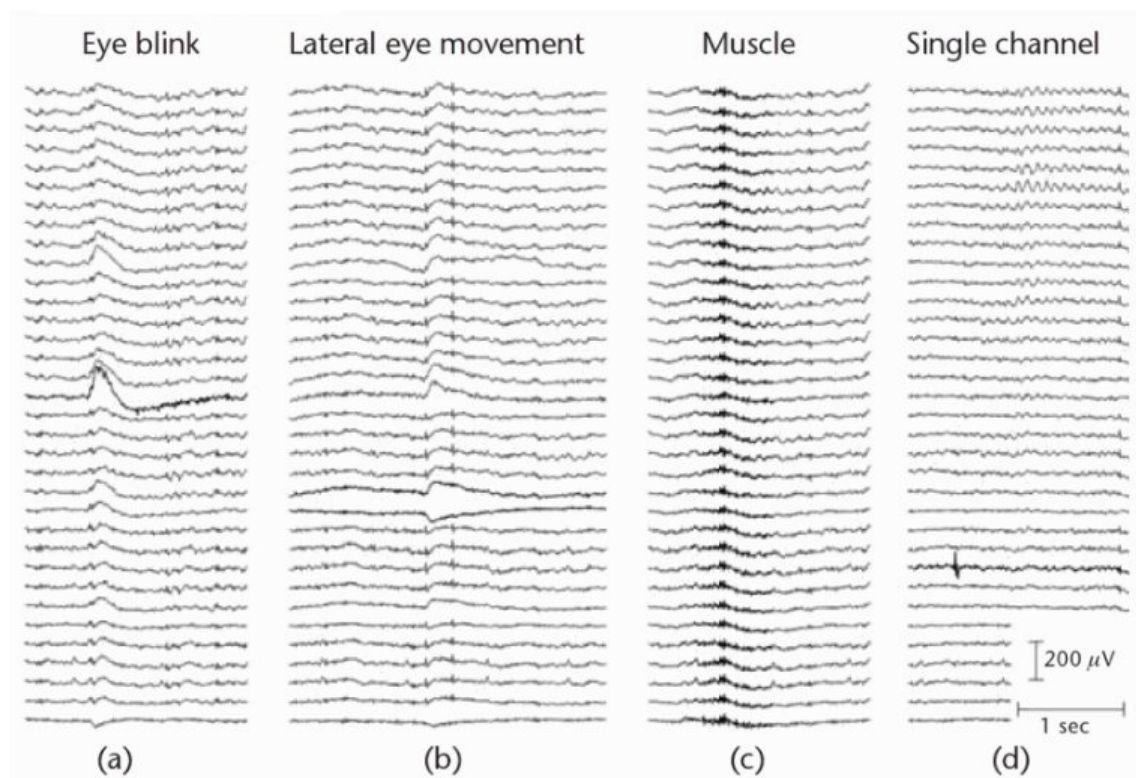
It is important to mention artifacts, which appear in the measured EEG signal. They occur during both voluntary and involuntary actions of the subject and always affect the signal quality. The presence of artifacts in the EEG signal is one of the main factors making them very hard to analyse and interpret. All artifacts have large impact on the information given by the signals and it is one of my main aims (but it is not only my concern as it affects everyone processing the EEG signals).

The artifacts may occur, when the subject moves or tenses jaw, blinks or closes/opens eyes. There are also other unwanted signals such as heart activity or response of skin potential – which can also be considered as artifacts [76, 85, 86]. These artifacts may be considered as biological factors. When the subject moves his eyes – the artifact is caused by Electrooculogram (EOG), the heartbeat artifacts are caused by – Electrocardiogram (ECG). Even the slightest muscle movement (Electromyogram – EMG) or breathing (Respiratory PNG) can also affect the signal with biological factors [85]. The artifacts may also appear as a side effect of an external stimulus, such as noise or any sound coming from the background [72].

### 3.2 Electrical Activity of Brain - Measurement Methods

It is crucial, while recording EEG signal, to attach the electrodes in a careful way, so there is a good contact with skin and high impedance. It has always been a problem with subjects with longer hair. But even if the electrodes have been placed carefully and they contact the scalp – various artifacts still can be seen in the EEG recording [76, 86]. The artifacts mainly affect the frontal electrodes, inter alia – 'F3' and 'F4' [85].

Figure 3.48 presented the main types (but not all) of artifacts that may occur in the analysed EEG signal. Mostly the artifacts have their source not in the external environment, but in the subject's body. Among these are inter alia: the artifacts caused by the eye blink or movement or any face- or body-muscle movement or only tension [72].



**Figure 3.52:** Sample of typical EEG artifacts [72].

The influence on the signal quality has also amplifier, as the low amplifier (especially when it comes to the analysis of signal with a very low frequency – below  $1 \mu\text{V}$ ) may cause that the noise level of the signal will be above the level

## 3.2 Electrical Activity of Brain - Measurement Methods

---

of this signal, what will result in a lower SNR (Signal to Noise Ratio) [72, 85]. It is important to improve SNR by improving the quality of the signal itself. Small SNR shows that the brain patterns are very hard to detect in the whole signal, where large SNR – makes the signal classification for the BCI purposes easier [6]. Despite implementing by many researches the steps in order to avoid the artifacts appearance and conducting the experiment in an isolated, laboratory environment, there is always a small number of artifacts that should be removed from the signals with the use of various filtration or other signal processing methods [72, 85].

### 3.2.2 Event-Related Potentials

Event-Related Potentials (ERP) are brief changes that occur in an EEG signal as a response to a sensory stimulus [4, 72]. They are not easy to detect, as they are mixed in numerous electrical signals in the brain, what makes their detection complicated, especially while reading the raw EEG record. In Figure 3.53 was shown ERP detected, while a person hears a sound [4]. Larger ERPs can be observed in the area of frontal lobes, when a motor activity had taken place. ERPs relating visual actions can be observed in the occipital area [76].

EEG may also be applied for detecting changes in the tested subject's arousal. In 1995 Shirley Hill conducted a research, where she presented repeatedly a low-pitched sound. The subjects had to respond to this stimulus. Sometimes she presented a high-pitched tone. This stimulus was unusual for the subjects, so she recorded their response. The response to the unusual tone would look in the EEG similar to the awake-state. Figure 3.54 presents a fragment of the measured signal with the response to the sound stimulus [15].

A typical ERP pattern consists of number of both negative (N) and positive (P) waves, that occur after the stimulus. N and P potentials are numbered in relation to their occurring time – e.g.  $N_1$  occurred 100 milliseconds after the stimulus. It is known, that ERP to external, sound stimulus such as spoken work, may contain patterns that enable differentiation of similar sounding work-pairs – such as 'cat' and 'rat'[4].

### 3.2 Electrical Activity of Brain - Measurement Methods

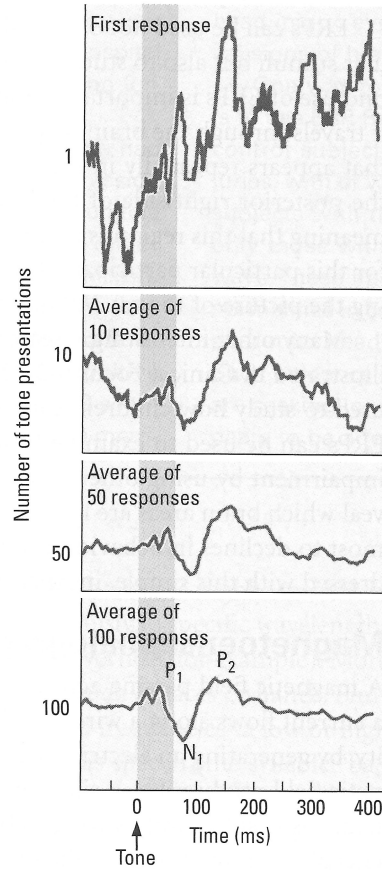


Figure 3.53: Presence of ERPs while hearing a sound [4].

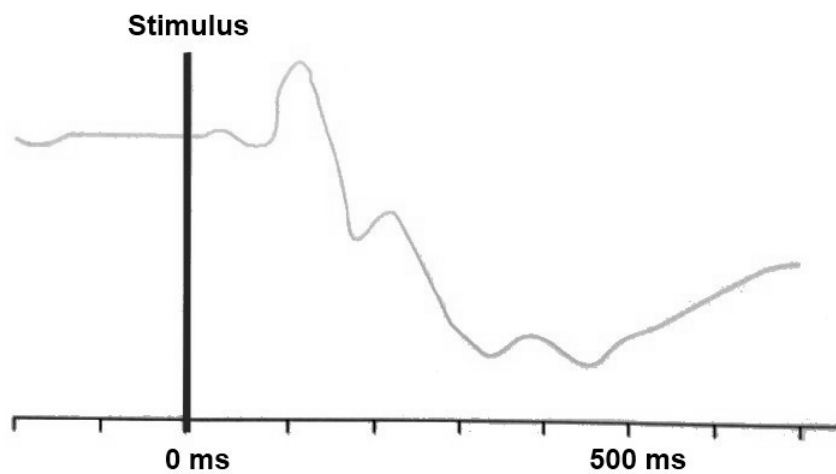


Figure 3.54: Evoked Potential as a result of hearing a tone [15].



## 3.2 Electrical Activity of Brain - Measurement Methods

---

Particular brain areas respond only to certain kinds of stimuli, what can be used in creating brain maps (Fig. 3.55) and this is also beneficial for the research. Another advantage of this research method is low cost and non-invasive character of experiments [4, 14, 72].

As it was mentioned above – ERPs respond to the various stimuli or sensory (e.g. cognitive) events and they consist of deflections and peaks. These peaks and deflections can be described by morphology, latency, topography or experimental manipulation, which are the ERP components. The ERP components are characterised with a relatively small amplitude – 1 to 20  $\mu\text{V}$ . They are also very sensitive and prone to various artifacts. An EEG signal consists of the sum of ongoing activity of the brain with a stimulus-related response independent from that activity. Figure 3.56 shows an additive ERP model [72].

The implementation of the ERP (combined with the EEG) can be found in various brain-computer interfaces [69]. Some of the already existing solutions, based on the ERP-technique were presented in Chapter – 'Literature Review'(2).

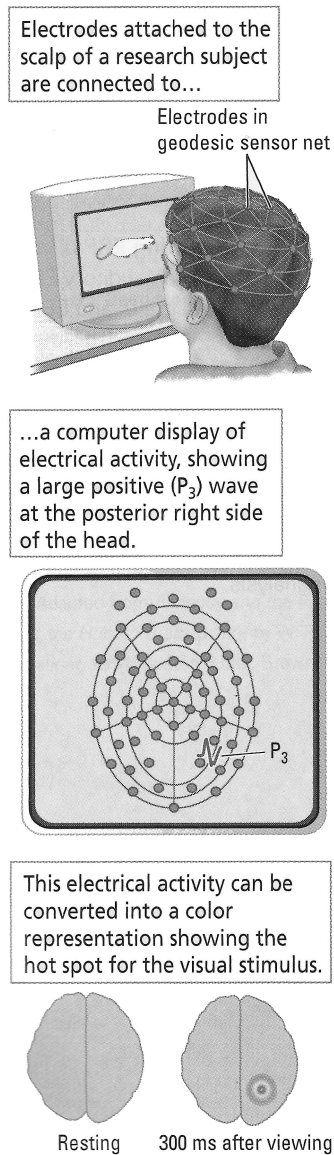
### 3.2.3 Magnetoencephalography Versus Electroencephalography

Magnetoencephalography is based on magnetic field passing across a wire, which induces electrical current there. Magnetic field produced by a single neuron is relatively small, but a group of neurons can provide field strong enough to be recorder on the scalp – the result of this is magnetoencephalogram (MEG), a counterpart of EEG and ERP [4, 13, 69]. MEG also enables recording rhythms from the cerebral cortex of the brain [13, 69, 87].

Figure 3.57 shows a model of magnetoencephalograph with 150 sensitive magnetic detectors [13].

The electroencephalography bases on recording electrical activity of brain, and electricity needs a conductor. In magnetoencephalography, according to the Maxwell's equations – no conductor is needed. No electrodes in MEG need to be attached to the scalp and the magnetic field generated by the brain can easily emerge through the skull and scalp with no distortion – what is one of the advantages of the MEG over the EEG [12, 87].

## 3.2 Electrical Activity of Brain - Measurement Methods



**Figure 3.55:** Brain activity imaging – basic scheme [4].

### 3.2 Electrical Activity of Brain - Measurement Methods

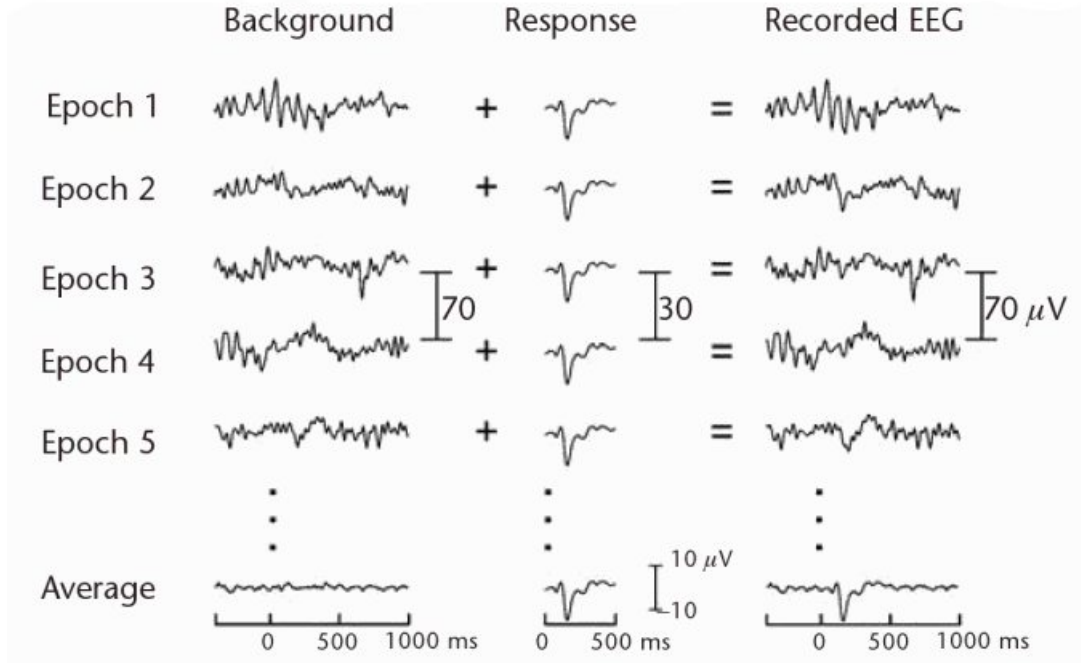


Figure 3.56: Additive ERP model [72].

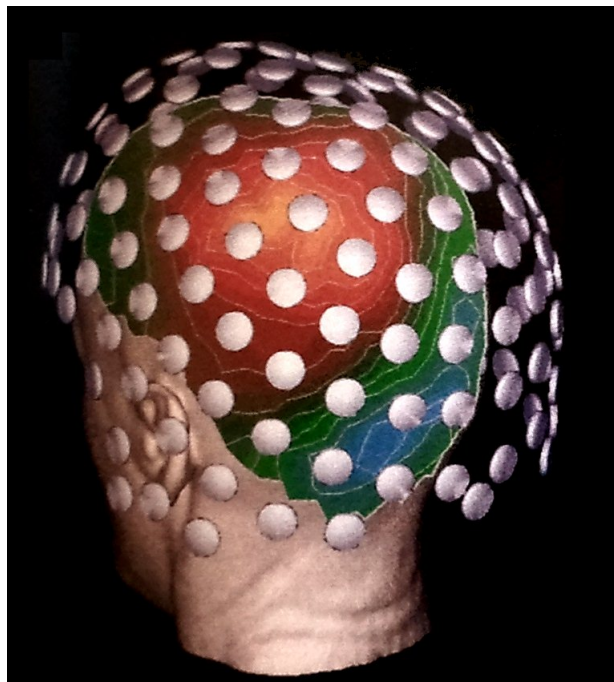
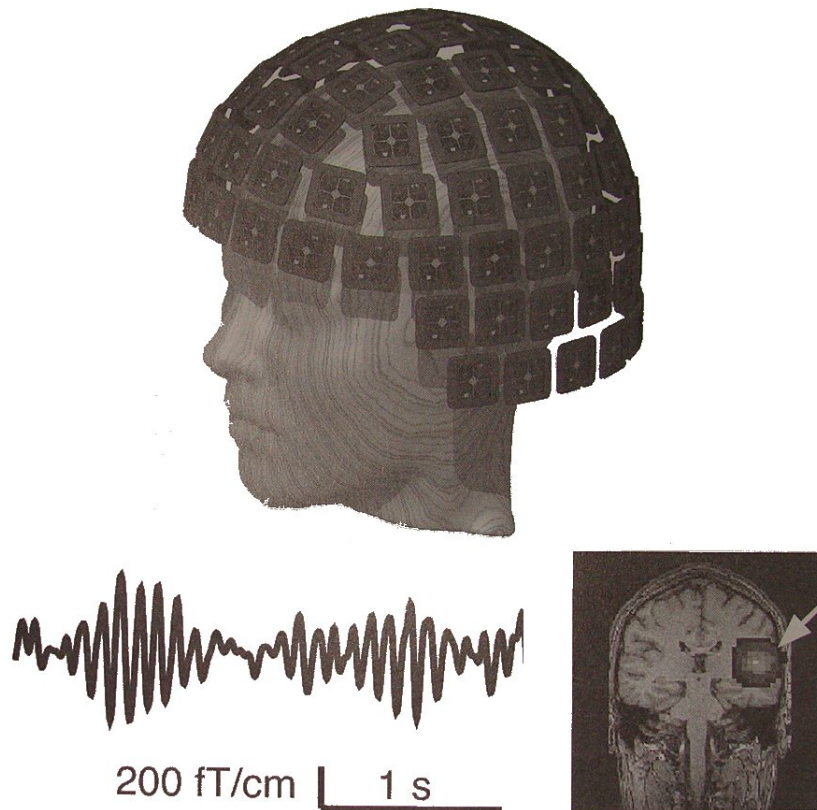


Figure 3.57: Magnetic detectors in MEG [13].

## 3.2 Electrical Activity of Brain - Measurement Methods

---

Presented in Figure 3.58 is a sample MEG, able to record brain responses outside the skull [12].



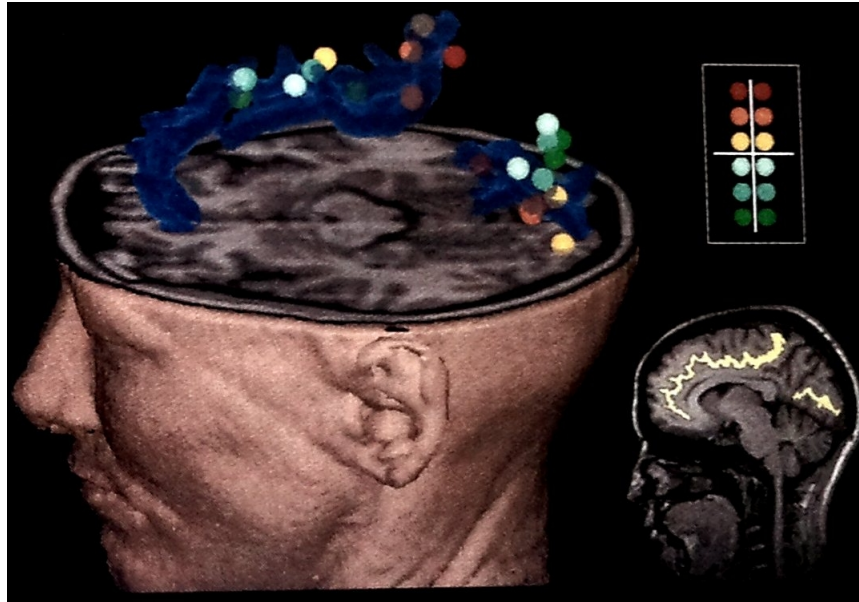
**Figure 3.58:** Sample magnetic detectors in MEG [12].

The advantages of the MEG include the fact that the measurements can provide both description of the electrical activity of neurons and the localisation of the cell generating the field. MEG can have also a better resolution than ERP and enables more precise identification of the signal source, than recorded using EEG or ERP technologies. One of the little disadvantages is the cost of the MEG [4].

Many researchers use the technology of MEG in order to estimate the location of sources of the neural activity of the brain. It also helps to create brain-maps with this sort of activity, was presented in the Figure 3.59 [13]. It is also believed that the magnetic flux recorded by the MEG is generated by the synchronised post-synaptic potentials (PSP) of pyramidal neurons [87].

## 3.2 Electrical Activity of Brain - Measurement Methods

---



**Figure 3.59:** Sample map of neural activity [13].

To the biggest disadvantages belong the requirements for the research conduct. The magnetic signals compared to the 'magnetic noise' that occur in the signal can be compared to the 'sound of the ant's footsteps during the rock concert' – impossible to notice. The measurement conduct requires an expensive screened room together with expensive device, with very sensitive magnetic detectors. These detectors have to be cooled with the helium to the temperature of -269 Celsius [12, 13].

The analysis of the measured MEG requires some complex steps in order to remove the artifacts and reduce the noise, what makes it similar to analysis of the measured EEG [87]. As the MEG signal is not the subject of this research – it was only mentioned in order to present other methods of recording brain activity.

# 4

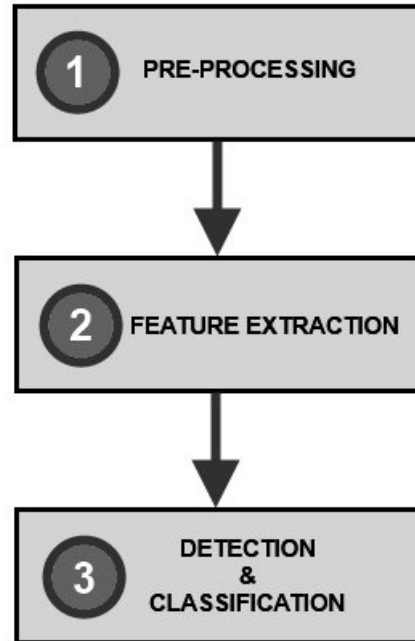
## Signal Processing - Overview

In order to obtain desired patterns from EEG signals it is necessary to process them. As the EEG signals have a very complex nature, the analysis is not easy and no perfect solution for extracting desirable features has not yet been found. This chapter presents in short various signal processing methods applied for EEG analysis and Brain-Computer Interface implementation purposes.

### 4.1 Signal Processing Methodology

As the EEG patterns have a very complex nature – their analysis is very hard. For the purposes of the raw data analysis mathematical tools such as Fourier Transform are being used [80]. It is also important to note the need for an amplifier while recording the signal according to the level of the SNR, as the measured signal is very weak. The Signal to Noise Ratio can also be poor and therefore the signal can be masked by the noise coming from external environment [72]. There are three stages of signal processing for the BCI implementation purposes – preprocessing, feature extraction and detection with classification, what was illustrated in Figure 4.1. Pre-processing means the process of simplified subsequent processing operation that would prevent from losing relevant data. The main aim of this phase is to improve Signal to Noise Ratio – SNR [6].

Processing of the EEG signals is mainly based on the filtering of these signals. The perfect filtering method has not yet been found, as ideally filter with perfectly flat characteristic does not exist. The filtering methods of the EEG signals will



**Figure 4.1:** Basic scheme of signal processing and classification [6].

be described in detail in the further part of this work. Filter and transforms application is also a part of stage one – pre-processing. It is performed in order to eliminate or reduce unwanted signal components, what can also improve the SNR. The next stage is to extract desired features using extraction algorithms in order to proceed with the stage three - detection and classification [6, 88, 89].

In order to proceed with the signal processing – it is important to define the concept of signal and to classify various sorts of them [90, 91]. Figure 4.2 presents the very basic classification of signals [90].

Bio-signals (including EEG signal) appear to be random (stochastic) signals, where it is impossible to predict the signal value in any time instant, only statistical measures may be used to determine their features (such as: mean, distribution). The stochastic signals can be divided into two groups: stationary and non-stationary, where the stationary signals can also be divided into ergodic and non-ergodic signals [90, 91, 92]. Signal is ergodic, when the time average is equal to the space average of a stationary signal.

Sample stochastic signal has been presented in Fig. 4.3 [90]. This Figure (Fig.

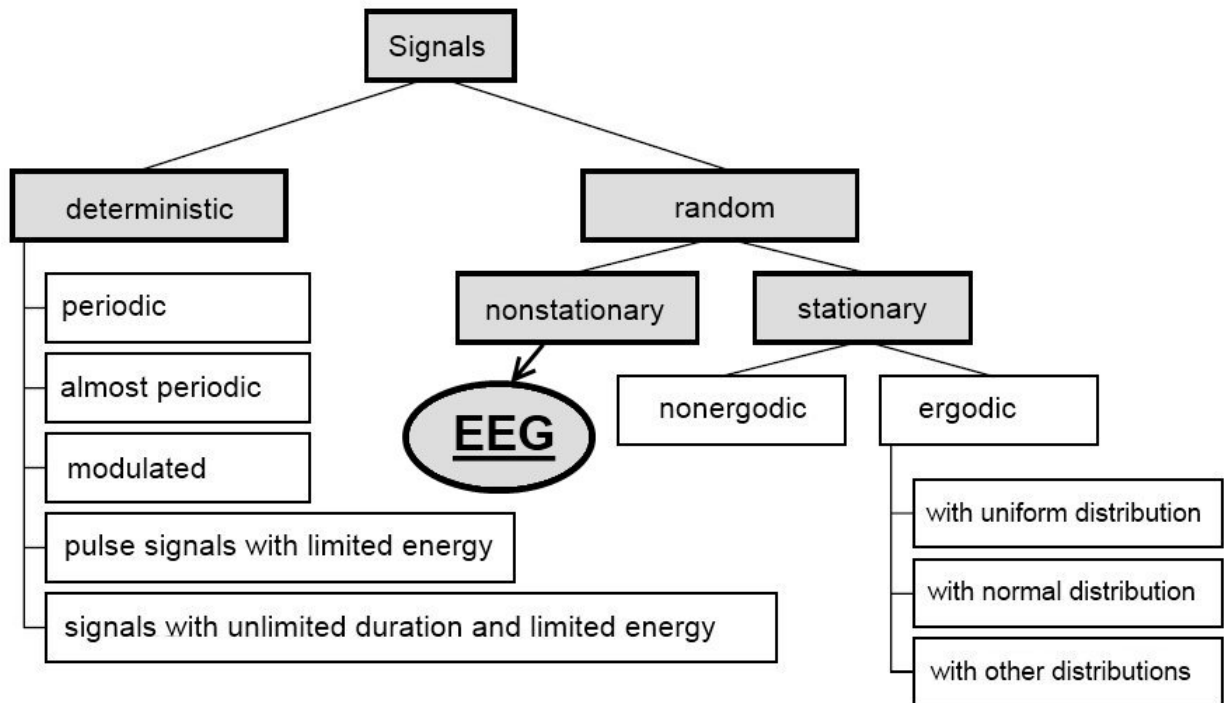
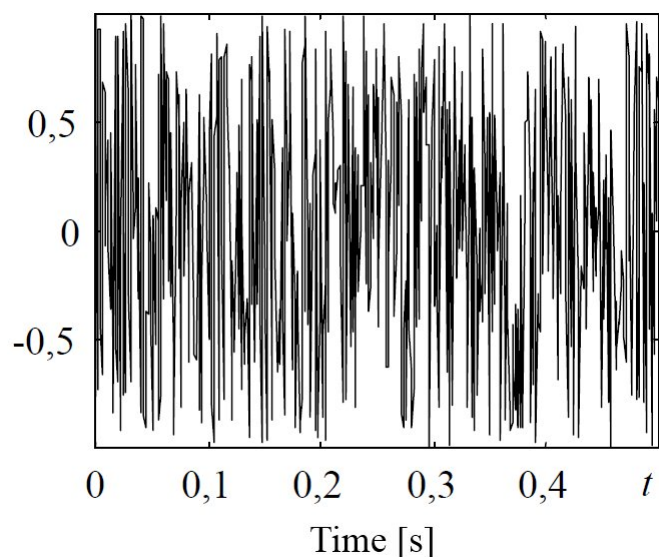


Figure 4.2: Basic signal classification [90].





**Figure 4.3:** Sample random (stochastic) signal [90].

4.3) shows that the pattern signal is well disguised.

In order to remove artifacts (or at least to decrease their influence on the signal) the following methods can also be used: 'simple amplitude threshold', 'min-max thresholds', 'gradient criterion', 'low activity', 'spectral distribution', 'standard deviation', 'joint probability'. In the implementation of the method based on using the 'simple amplitude threshold' relies on defining positive and negative amplitude levels which are above or below the levels, where the data would be automatically assumed as an artifact. In the analysis based on 'min-max thresholds' – the amplitude difference is set to the maximally allowed level in relation to the previously specified time length. This method may seem to be similar to the method based on the amplitude criterion, the difference is that it can be used for DC-coupled recordings as it is independent from the absolute threshold values. The next one is the method based on the 'gradient criterion', where the artifact criterion is being defined according to the changes of the voltage. 'Low activity' method of artifacts removal is based on defining the minimum difference between the highest and the lowest values in a previously set length of time. It enables the detection of the channel saturation or hardware channel failures. The 'spectral distribution' – is based on the spectral composition, which enables

definition of the artifact time stretches [72].

### 4.1.1 Filtering

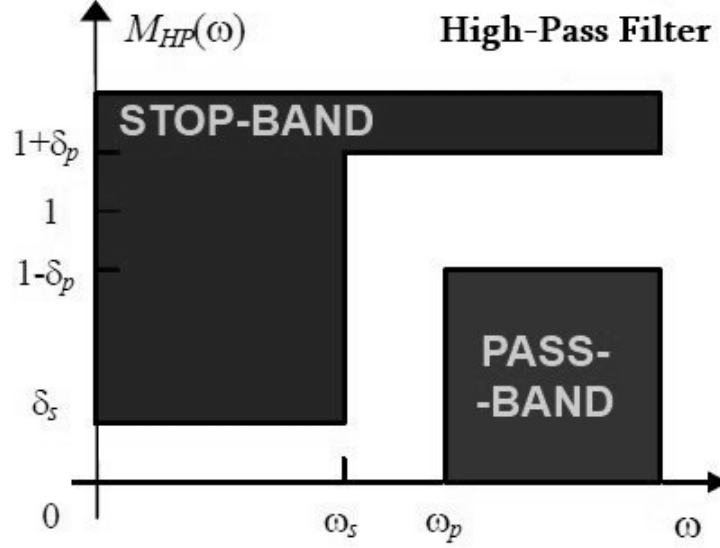
Implementation of filters and transforms is a part of the first stage, in three stages process, in signal processing – pre-processing. The role of filtering is to eliminate or reduce unwanted signal components and as a result – improve SNR [6].

Filters can be divided into four main types – high-pass-, low-pass-, band-pass- and band-stop-(also known as notch-filters) filters. It is possible to use all of them for not only the EEG-signal processing purposes, but also for analysing any other bio-signal [72, 90].

While implementing a high-pass filter only, it is important to choose the appropriate high pass edge frequency and order according to the values of required measures [72]. The filter is characterised with the high-cut in the frequency band [69, 92, 93]. Equation 4.1 presents the high-pass filter calculation according to the estimated values, which the modulus characteristic  $M(\omega)= |H(j\omega)|$  may assume for any pulsation  $\omega$ , which equals  $2\pi f$ . The ripple factor has been marked as  $\delta$ . Figure 4.4 illustrates sample modulus characteristic of the high-pass filter [90].

$$\begin{cases} 0 \leq |H_{HP}(j\omega)| \leq \delta_{stop} & \text{for } |\omega| \leq \omega_{stop} \\ 0 \leq |H_{HP}(j\omega)| \leq 1 + \delta_{pass} & \text{for } \omega_{stop} < |\omega| < \omega_{pass} \\ 1 - \delta_{pass} \leq |H_{HP}(j\omega)| \leq 1 + \delta_{pass} & \text{for } \omega_{pass} \leq |\omega| \end{cases} \quad (4.1)$$

The analysis with the use of low-pass filters is similar to the one with implementation of the high-pass filtering, but we have to set up the low-pass edge in order to exclude unwanted lower values [72]. Low-pass filter is characterised with the low-cut in the frequency band [69]. Equation 4.2 shows how to calculate the estimated values, which the modulus characteristic  $M(\omega)= |H(j\omega)|$  may assume for any pulsation  $\omega = 2\pi f$  and  $\delta$  as a ripping factor. Figure 4.5 shows sample modulus characteristics of the low-pass filter [90, 92, 93].



**Figure 4.4:** Approximate modulus characteristic of a sample high-pass filter [90].

$$\begin{cases} 1 - \delta_{pass} \leq |H_{LP}(j\omega)| \leq 1 + \delta_{pass} & \text{for } |\omega| \leq \omega_{pass} \\ 0 \leq |H_{LP}(j\omega)| \leq 1 + \delta_{pass} & \text{for } \omega_{pass} < |\omega| < \omega_{stop} \\ 0 \leq |H_{LP}(j\omega)| \leq \delta_{stop} & \text{for } \omega_{stop} \leq |\omega| \end{cases} \quad (4.2)$$

Band-pass filtering combines the features of the both – low-pass- and high-pass-filters, but has some disadvantages. The approximate modulus of the band-pass filter is presented in Fig. 4.6, where Equation 4.3 shows the calculation of the estimated values for any pulsation  $\omega$  for the modulus characteristic  $M(\omega) = |H(j\omega)|$  [90].

$$\begin{cases} 1 - \delta_{pass} \leq |H_{BP}(j\omega)| \leq 1 + \delta_{pass} & \text{for } \omega_{pass1} \leq |\omega| \leq \omega_{pass2} \\ 0 \leq |H_{BP}(j\omega)| \leq \delta_{stop} & \text{for } |\omega| \leq \omega_{stop1} \vee \omega_{stop2} \leq |\omega| \\ 0 \leq |H_{BP}(j\omega)| \leq 1 + \delta_{pass} & \text{for } \omega_{stop1} < |\omega| < \omega_{pass1} \vee \omega_{pass2} < |\omega| < \omega_{stop2} \end{cases} \quad (4.3)$$

The notch-filters are very steep filters designed in order to filter out a very narrow frequency band [72]. This filter is very sharp and reduces the certain signal frequency. It may be applied for filtering out the artifacts coming from the

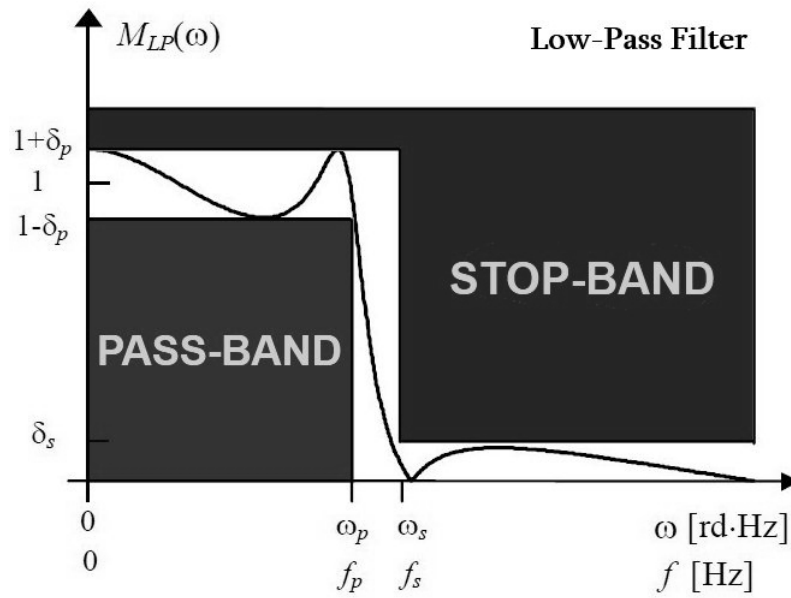


Figure 4.5: Modulus characteristic for a sample digital low-pass filter [90].

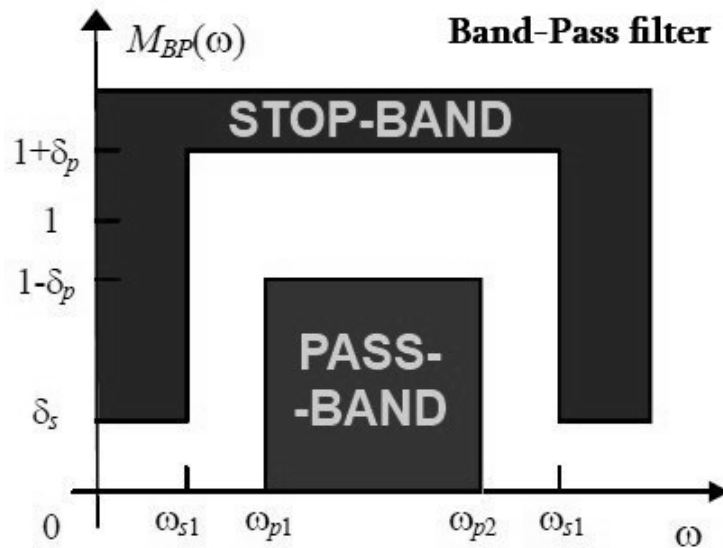
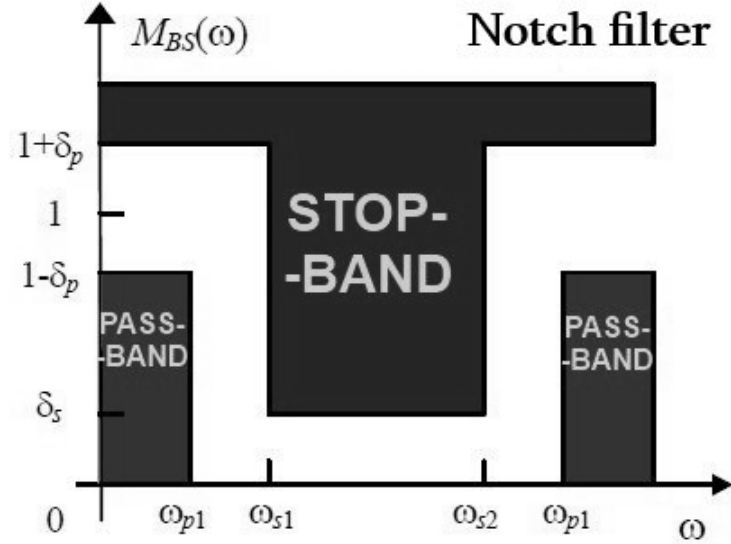


Figure 4.6: Approximate modulus characteristic of a sample band-pass filter [90].



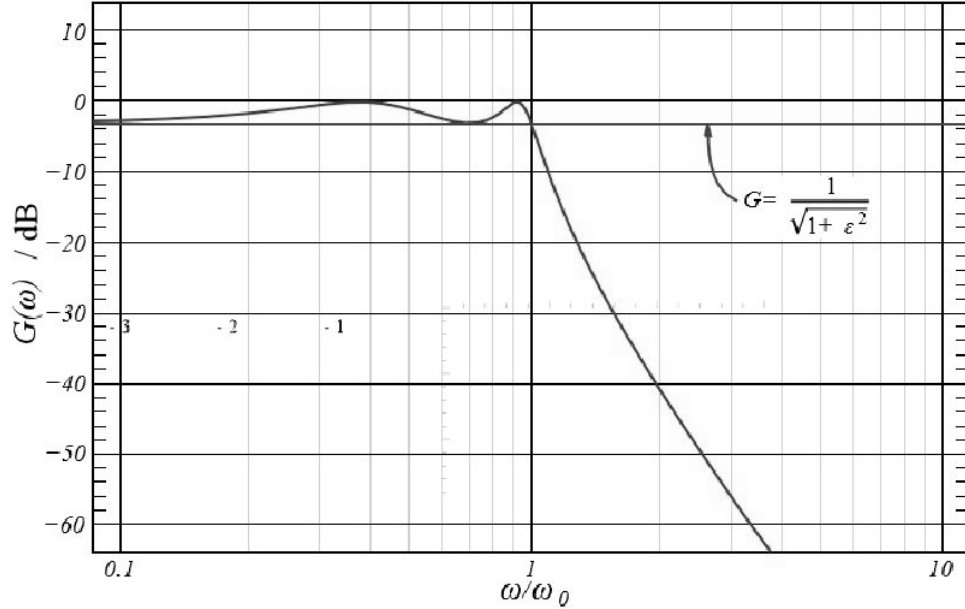
**Figure 4.7:** Approximate modulus characteristic of a sample (notch) band-stop filter [90].

electrical system in the room, where the research is taking place [69]. Equation of a typical notch-filter is shown below 4.4, where the sample modulus characteristic of this filter is illustrated with Figure 4.7 [90].

$$\left\{ \begin{array}{ll} 1 - \delta_{pass} \leq |H_{BS}(j\omega)| \leq 1 + \delta_{pass} & \text{for } |\omega| \leq \omega_{pass1} \vee \omega_{pass2} \leq |\omega| \\ 0 \leq |H_{BS}(j\omega)| \leq \delta_{stop} & \text{for } \omega_{stop1} \leq |\omega| \leq \omega_{stop2} \\ 0 \leq |H_{BS}(j\omega)| \leq 1 + \delta_{pass} & \text{for } \omega_{pass1} < |\omega| < \omega_{stop1} \vee \omega_{stop2} < |\omega| < \omega_{pass2} \end{array} \right. \quad (4.4)$$

For the purposes of the use of each of the four filters mentioned above – low-pass (LP), high-pass (HP), band-pass (BP) or notch (BS) it is possible to use one of four kinds of approximation – required by the modulus characteristic. On the choice of approximation depends the presence or lack of ripple in the filtering band. These are the following types of approximation: Butterworth, Chebyshev (Type I and II), Elliptic and Bessel. The Butterworth approximation has almost perfectly flat characteristic [90].

Chebyshev I filters (Fig. 4.8) are also frequently applied for EEG-signals processing [94].



**Figure 4.8:** Chebyshev I filter [94].

Figure 4.9 illustrated a an example of a sample raw (top) and filtered (bottom) EEG signal in the time-domain [5].

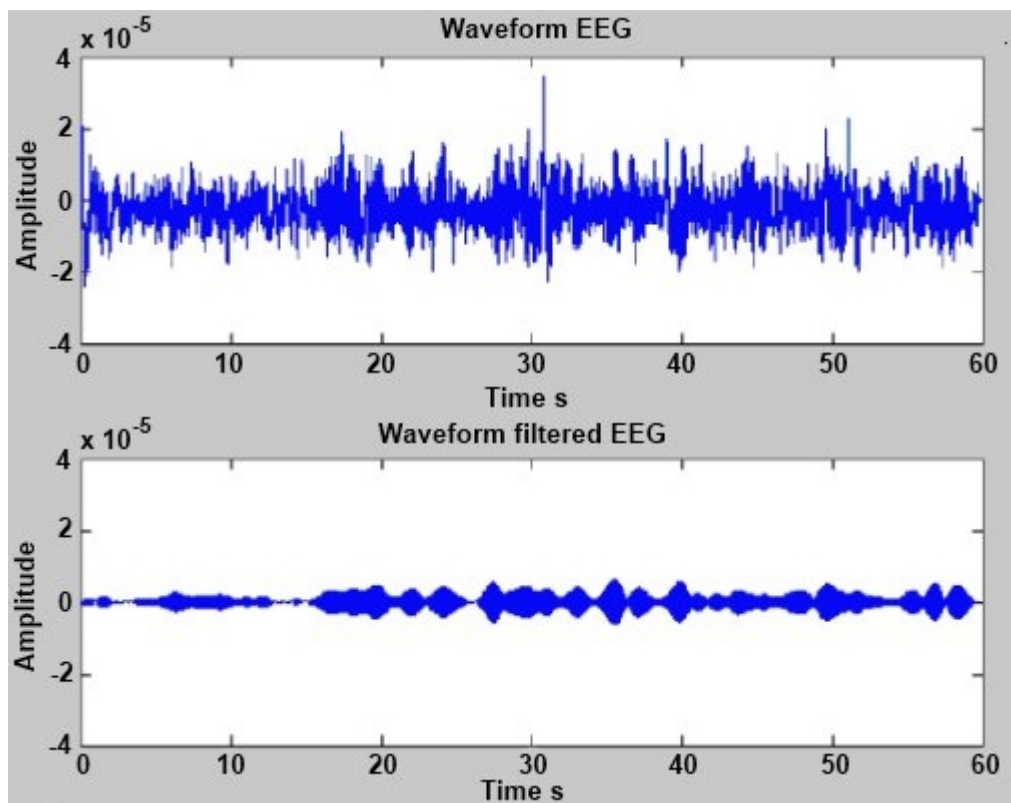
Figure 4.10 presented a an example of a basic scheme of Butterworth filter for each brain rhythm frequency [95].

Digital filtering has similar frequency requirements as the analogy one. It is necessary to specify the modulus characteristics of filter  $H(e^{j\Omega})$ , where the normalised pulsation  $\Omega$  is equal to  $2\pi f/f_{pr}$ , where  $f$  – frequency and  $f_{pr}$  – frequency sampling, and is concluded in the range  $[-\pi, \pi]$ . Same as in the case with the analogue filters – we can differentiate four main types of digital filters – low-pass (LP), high-pass (HP), band-pass (BP) or band-stop (notch – BS) [90, 92, 93].

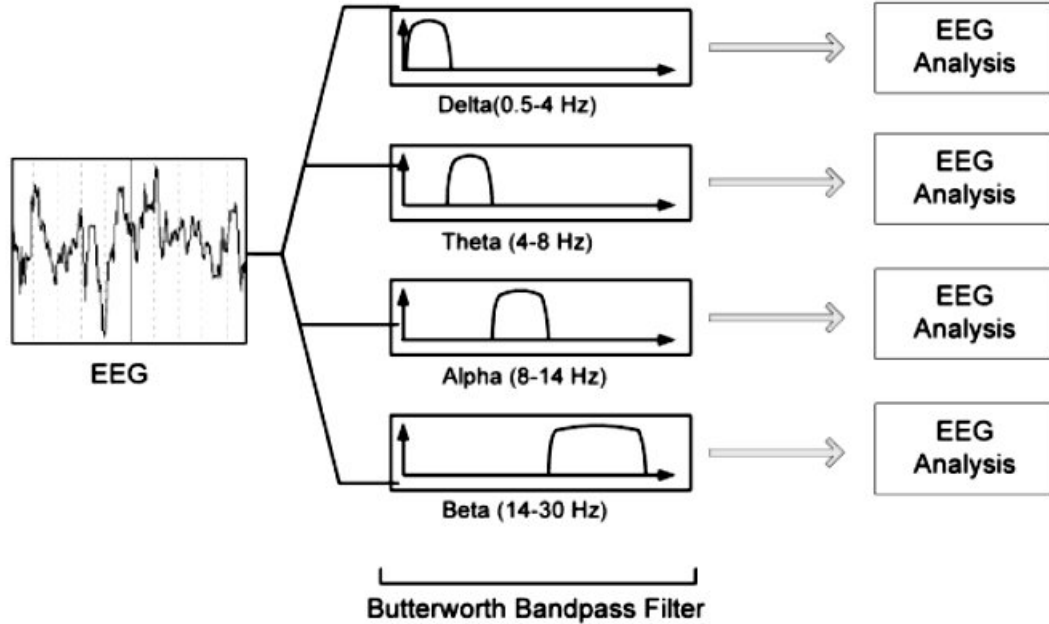
$$|H_{LP}(e^{j\Omega})| = \begin{cases} 1 \pm \delta_{pass} & \text{for } |\Omega| \leq \Omega_{pass} \\ 0 + \delta_{stop} & \text{for } |\Omega| \geq \Omega_{stop} \end{cases} \quad (4.5)$$

$$|H_{HP}(e^{j\Omega})| = \begin{cases} 0 + \delta_{stop} & \text{for } |\Omega| \leq \Omega_{stop} \\ 0 \pm \delta_{pass} & \text{for } |\Omega| \geq \Omega_{pass} \end{cases} \quad (4.6)$$

$$|H_{BP}(e^{j\Omega})| = \begin{cases} 1 \pm \delta_{pass} & \text{for } \Omega_{pass1} \leq |\Omega| \leq \Omega_{pass2} \\ 0 + \delta_{stop} & \text{for } |\Omega| \leq \Omega_{stop1} \vee |\Omega| \geq \Omega_{stop2} \end{cases} \quad (4.7)$$



**Figure 4.9:** Sample EEG signal filtered in the time-domain [5].



**Figure 4.10:** Simplified Butterworth filter design for particular frequency band [95].

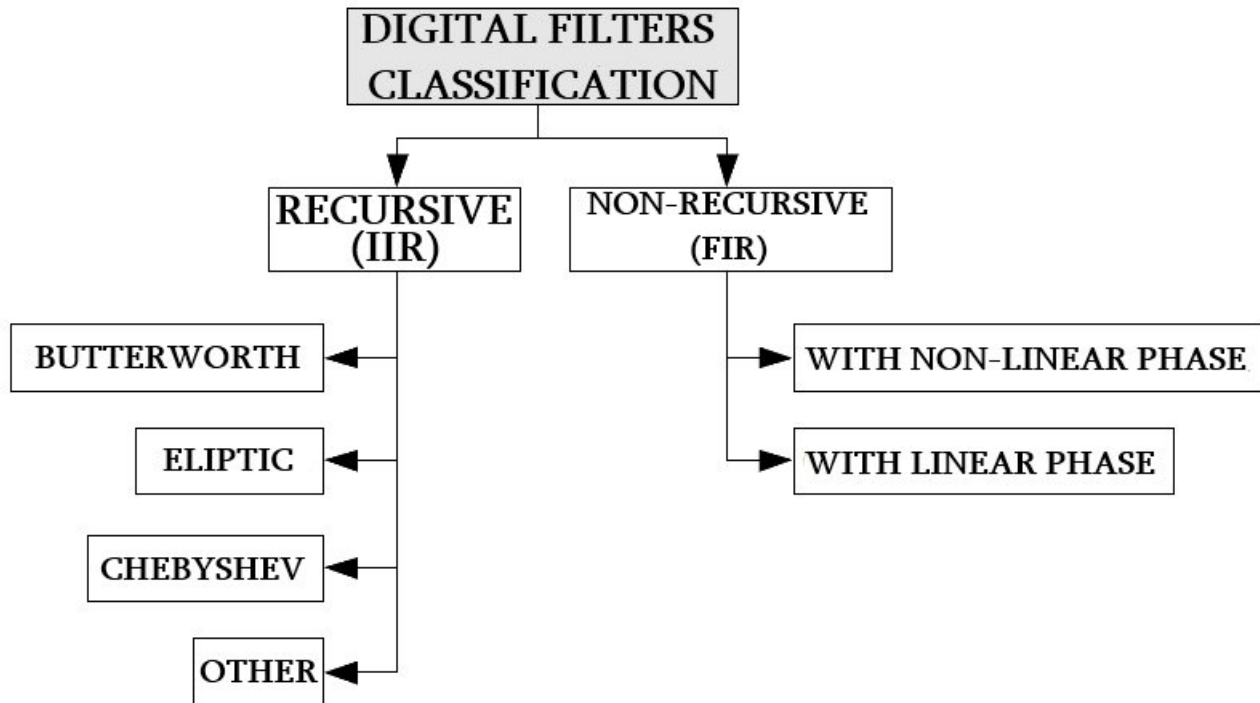
$$|H_{BS}(e^{j\Omega})| = \begin{cases} 0 + \delta_{stop} & \text{for } \Omega_{stop1} \leq |\Omega| \leq \Omega_{stop2} \\ 1 \pm \delta_{pass} & \text{for } |\Omega| \leq \Omega_{pass1} \vee |\Omega| \geq \Omega_{pass2} \end{cases} \quad (4.8)$$

Equation 4.5 is for estimating values in low-pass digital filtering, where Equations 4.6, 4.7, 4.8 are respectively for: high-pass-, band-pass- and notch-filters. For all filters, all band-pass characteristic should comply the condition stated in the Equation 4.9, where the modulus characteristic  $M(\Omega) = |H(e^{j\Omega})|$  for any pulsation  $\Omega$  should be contained in the range  $[-\pi, \pi]$  for any type of filter [90, 92].

$$0 \leq |H(e^{j\Omega})| \leq 1 + \delta_{pass} \quad (4.9)$$

Figure 4.11 presented simplified classification of digital filters. The filters can be divided into the two main groups – recursive and non-recursive. The recursive filters characterise with Infinite Impulse Response (IIR), where the non-recursive filters have Finite Impulse Response (FIR). The most popular approximations for IIR are Butterworth-, Chebyshev- and elliptic-filters. The non-recursive filters





**Figure 4.11:** Digital filters classification [90].

can be divided into those with linear and those with non-linear phase [90, 96].

#### 4.1.2 Other Filters Applied in EEG Signal Processing – Spatial Filtration

One of the most efficient and recently popular filtering method applied for EEG signal processing is the implementation of various spatial filters – such as Laplacian filters. The Laplacian filters are usually applied in order to analyse signals concentrated on a single neuronal cluster and are particularly useful for the study of cortical dynamics. The Laplacian filtering is conducted by computing analytical interpolation Laplacian function. A disadvantage of this filtering method is that only high-pass EEG signals can be filtered and therefore middle frequency range is not emphasised [97]. Spatial filtering has not been applied for this study purposes.

### 4.1.3 Wavelet Systems

Wavelet Transforms are usually applied in order to convert complex signals from time to frequency domain. In opposite to widely applied Fourier Transforms they enable signal analysis in both – time and frequency domains [85]. Wavelet Transforms may also be applied to differentiate time-frequency representation. In EEG signal processing Wavelet Transforms combined with Independent Component Analysis (ICA), Principal Component Analysis (PCA) and with implementation of various neural networks may bring accurate and efficient results [98]. Although use of all these statistical features extraction methods is efficient, it is inapplicable for the method chosen for this study, as it requires too high computing power and therefore cannot be implemented on embedded platforms. Initial tests carried out for this research purposes involved implementation of Morlet Wavelet Transform. The results were not satisfactory due to the latency appearance in processed signal. Application of Wavelet Transform also requires high computing, what makes it unsuitable for implementation on embedded platforms. It is possible to differentiate various Wavelet types, such as Daubechies Wavelet function [99].

### 4.1.4 Transforms

As the EEG signals have non-stationary character, the most common analysis of them is based on the Fast Fourier Transform (FFT) [90, 100]. The most popular transform used for signal processing is the Fourier Transform, although it is possible to differentiate other transforms, which are going to be shortly presented in the further part of this work. The main aim of the Fourier transform (FT) is to transform the function from time-domain to the frequency domain, what enables another dimension of events analysis, and simplifies this task in case of complex or difficult signals – where the analysis in the time-domain would be extremely difficult or impossible [101, 102].

The Fourier Transform is a limiting case of the Fourier Series in case the period approaches infinity (Equation 4.10) or in terms of frequency (Equation 4.11) [103].



Figure 4.12: FFT computation sample scheme [89].

$$F(\omega) = \int_{-\infty}^{\infty} f(t)e^{-i\omega t} dt \quad (4.10)$$

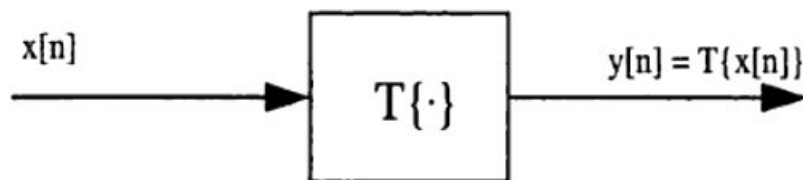
$$F(f) = \int_{-\infty}^{\infty} f(t)e^{-i2\pi ft} dt \quad (4.11)$$

One of the transformed used for the BCI purposes is the Discrete Harley transform (DHT) [91, 94]. DHT belongs to the wide family of Fourier transforms. This transform is discrete, periodic data what makes it similar to the discrete Fourier transform (DFT). DHT was originally proposed for fast transform of real inputs into real outputs without intrinsic involvement of numbers, what made it a fast solution, by Bracewell in 1983. Fast Harley transform (FHT) in opposite to the Fourier transform produces real output from the real input. It is also able to provide the same phase and amplitude information. It is also twice as fast as the FFT [94].

As it was mentioned above, the most popular transform used for the EEG signal processing is the FFT – Fast Fourier Transform, which is a faster version of the Fourier transform or discrete Fourier transform [89, 101].

Figure 4.12 shows sample computation of the Fast Fourier Transform (FFT) in order to receive the magnitude spectrum [89].

To the family of discrete-time transforms belong the following transforms: Discrete Fourier Transform (DFT), Fast Fourier Transform (FFT), Discrete Cosine Transform, Discrete Hartley Transform, Discrete Hilbert Transform, Discrete Fractional Hilbert Transform, Discrete-Time Wavelet Transform, Discrete Walsh Transform and Discrete Hadamard Transform. These transforms are important to mention, as they are a very important and powerful tool in digital signal processing, as they provide representation based on frequency for various discrete-time



**Figure 4.13:** Sample discrete-time system [91].

signals and systems. Fig. 4.13 shows a sample discrete-time system, which transform an input discrete time sequence  $x[n]$  into an output discrete-time sequence  $y[n]$  according to the Equation 4.12 [91].

$$y[n] = T \{x[n]\} \quad (4.12)$$

#### 4.1.5 Time-Frequency Signal Processing

The time-frequency analysis of signals has a broad application for not only bio-signals such as EEG, but other signals as well. This kind of analysis can be used for non-stationary, non-Gaussian signals – such as electroencephalographic signals. The time-frequency analysis is based on cutting the signal into slice segments, which are later processed with the use of Fourier analysis. As the EEG signals do not have a periodic character, the segments into which the signal has been cut, will be interpreted as discontinuity or abruptness [5]. One of the methods in order to avoid such artifacts is to apply windowing instead of slicing the signal into the segments which do not have periodic characteristic. Some of the windows used for the purpose of processing the EEG signals are: Hamming, Hanning, Kaiser and Barlett [5, 90].

Time-Frequency analysis has been applied to this study. It is a non-linear, quadratic transformation, frequently used for non-stationary signals processing. Time-Frequency method uses both time and frequency joint functions. Fourier transform together with linear model have been used for analysis and pattern-recognition of EEG signals [99, 104].

### 4.1.6 Independent Component Analysis

Independent Component Analysis (ICA) is used for original signals separation. It may be used in case only limited information in the original signal is available. ICA is a signal processing technique, which estimated statistically independent source signals from their linear combinations. It is not only applied in EEG signal processing, but also other signals such as – speech, voice, music, etc. The criterion for ICA implementation involves minimisation of the mutual information presented in form of high order cumulants function. ICA enables signals separation into distinct components, what – particularly EEG signal processing – enables easier features extraction [36, 85, 98].

In EEG signal recordings it is possible to observe high-frequency cortical potentials, which may be confounded with scalp muscle activities. Independent Component Analysis enables to decompose signal and as a result – to remove these artifacts [105]. ICA may also be treated as an efficient Blind Source Separation (BSS) technique. It enables revealing hidden factors of signals in order to extract individual signals from mixtures. ICA technique relies on assumption that different physical processes generate unrelated signals [106].

The newest version of EEGLab provides Independent Component Analysis option [107], which may be used for the post-doctoral, further research purposes.

### 4.1.7 Principal Component Analysis

Principal Component Analysis (PCA) is a sophisticated technique using mathematical principles in order to transfer possibly correlated variables into principal components. It is also one of Brain Source Separation (BSS) methods [108]. PCA is an efficient method for removing ocular artifacts from the EEG signals, however these artifacts are uncorrelated with the EEG signals. PCA is also unable to separate eye-movement artifacts or these occurring by EMG or ECG activity [85].

PCA is often compared to the ICA technique. The main difference between the both methods is that raw PCA components have orthogonal activation and scalp distributions, where ICA finds temporally independent components with non-orthogonal scalp distributions citescn.

# 5

## Pilot Study Using Customised Equipment for BCI System

In this chapter details of initial studies carried out on implementation of the bio-patterns recognition method were presented. The very first stage in this research relied on using customised, self-made EEG equipment. It also included analysis of the EEG signals obtained from various open source data bases in order to practice processing of these bio-signals. In this section also the whole process of building the customised device and attempts for using it for the research purposes.

### 5.1 Rationale for a Study – Using Customised Equipment

As it was mentioned in chapter 'Signal Processing – Overview'(4) – analysis of the EEG signals is a very complex problem. This is caused by the specific characteristic of this bio-signal. The idea of this research project, which involved both analysis and implementation of various bio-signals, appeared at first in 2006. This was caused by the activity in the Students' Research Group 'nano' – established by author of this dissertation. Growing interest in bio-signals and its possible application in the process of controlling external devices was mainly caused by the need and desire to help physically handicapped people in their daily tasks. This would involve improvement of their motor activity, which led to enable to

## 5.1 Rationale for a Study – Using Customised Equipment

---

restore at least partial control ability in case it was lost as a result of an accident or injury.

The main reason for attempts to design and build customised equipment was a high prices and low accessibility of a professional EEG device. It was also caused by the need of building equipment that would fully meet the needs and expectations of the study. In sections – 'Research Methodology – Using Customised Equipment'(5.3) and 'Implementation – Using Customised Equipment'(5.4) the whole research methodology and the customised equipment used at this stage were in detail presented.

The beginning of the whole research process involved speech signal processing. Voice recognition, despite the fact that it appeared to be irrelevant to the study, was a valuable practice in bio-signals processing. Speech is the easiest bio-signal for analysis purposes and a 'start signal' used for initial tests. Relevance to the current research was that these signals were used to test and master the pattern recognition algorithm. The work on voice recognition resulted in Master's project. That project was based on a small application written in MATLAB and was based on the control of a toy – a car with the simple implementation of the voice recognition. That work consisted of two parts - the theoretical part, which described the process of speech generation (including presentation of the whole voice system) and the second part - practical one – consisted of design and implementation of electronic control system.

Doctoral project – as result of further education – also involved analysis of bio-signals. After obtaining experience and practice in bio-signal processing (voice recognition) – the research theme concerned signals generated through electrical activity of the brain. At the very early stage of the research there were plans to design and build electroencephalograph. The device has been built and initially tested, what was presented in section – 'Implementation – Using Customised Equipment'(5.4). Section – 'Data Acquisition – Using Customised Equipment'(5.5) also presented as well some initial tests conducted on data obtained from open source data-bases as the analysis of signals obtained from the built EEG. The results have been presented in section – 'Results Evaluation – Using Customised Equipment'(5.6) and discussed in – 'Discussion – Using Customised Equipment'(5.7).

## 5.2 Objectives and Expected Results – Using Customised Equipment

Below is in short specified the main objectives related to the first stage of the research:

- Review literature in the area of Human-Computer Interfaces and bio-signals processing.
- Gain experience in bio-signals processing using speech signal for a start.
- Review literature in electroencephalography and implementation of EEG signals for the BCI purposes.
- Conduct initial tests on EEG signals obtained from open source data bases.
- Review various signal processing techniques such as application of Morlet Wavelet.
- Design customised EEG with two active electrodes.
- Construct the electroencephalograph.
- Run tests using the built equipment.
- Verify the results.

## 5.3 Research Methodology Applied – Using Customised Equipment

In order to meet the above specified objectives – 'Objectives and Expected Results – Using Customised Equipment'(5.2) it was necessary to thoroughly review the literature in the area of study on Human-Computer Interfaces. This was motivated by the potential implementation of various bio-signals for the control purposes. The literature review objective was achieved in two steps – initially



## 5.4 Implementation – Using Customised Equipment

---

the main focus was purely put on the BCI interfaces as the potential source of bio-signals. After conducting some initial tests with speech and EEG signals the better potential of the latter was discovered. From this moment the whole effort was directed toward using the EEG signals for the control purposes.

In the context of potential implementation various kinds of signal analysis methods were taken into account including Morlet Wavelets. The use of Morlet Wavelets and the obtained results were presented in section – 'Results Evaluation – Using Customised Equipment'(5.6).

The natural consequence of the literature review and investigation of the existing tools and methods led to approach to the design and construct of a customised equipment with two active electrodes. Due to time and resource constraints the customised electroencephalograph turned out to be of no satisfactory quality. The whole process of design and building the customised equipment was described in detail in section – 'Implementation – Using Customised Equipment'(5.4)

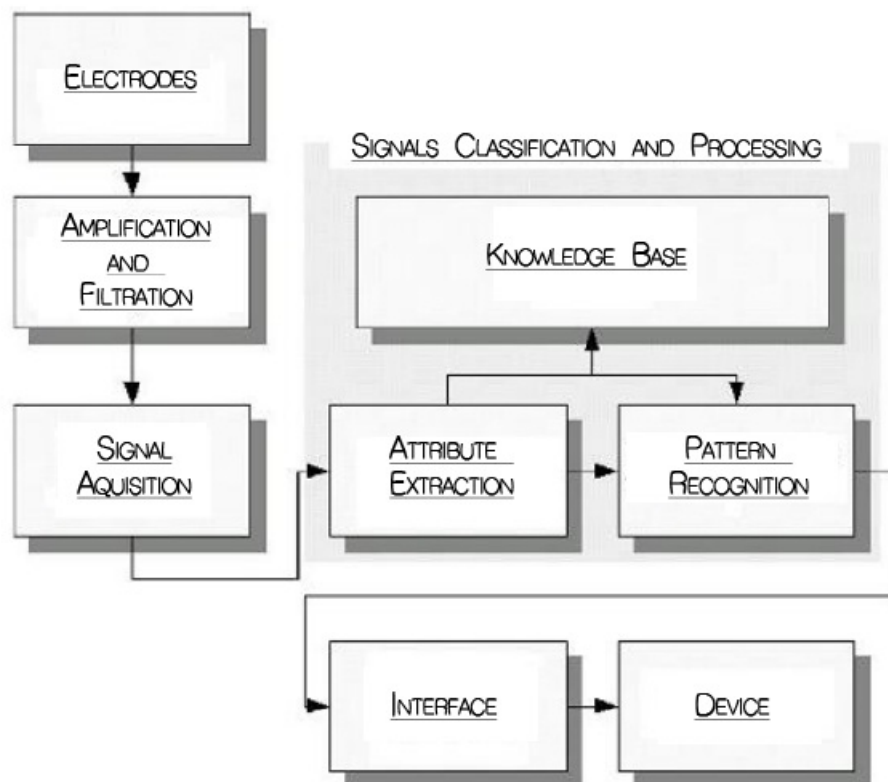
Conducted initial tests proved that the quality of the final design was not satisfactory and thus the accuracy was low. The gained signals were of very poor quality and unsuitable for the further research purposes. The implementation of the Morlet Wavelets proved that this method is not suitable for Brain-Computer Interfaces due to the latency appearance, where fast (if not immediate) response is required. The full verification of the results was presented in section – 'Results Evaluation – Using Customised Equipment'(5.6).

## 5.4 Implementation – Using Customised Equipment

The main objective of the this stage was the design and construction work of the customised electroencephalograph. The device contained two active electrodes. Potential implementation of the active electrodes was very significant for the research purposes and will be explained further in this chapter. This stage also implied analysis of EEG samples gained from the following open source databases – BCI2000 Project, Schwartz Center for Computational Neuroscience (for

## 5.4 Implementation – Using Customised Equipment

basic analysis), and for more complex analysis – signals used for BCI Competition [18, 107, 109]. The initial tests with the EEG sample were carried out in MATLAB and presented in section – 'Data Acquisition – Using Customised Equipment'(5.5).



**Figure 5.1:** Schema of data flow in the system.

## 5.4 Implementation – Using Customised Equipment

---

In Figure 5.1 data flow in the proposed system was presented. The idea of the data flow in the design and constructed system was that the two active electrodes (placed according to the '10-20 System' in C3 and C4 positions – shown in Fig. 5.2) recorded signal from the scalp. The signal had to be amplified and filtered with the implementation of customised application. The potential attributes of the signals would be extracted according to the data stored in a knowledge base. The acquired data compared to the signal stored in the data base would allow pattern recognition. Based on the result of the pattern recognition – the data would be sent to the interface and the control of an external device would be possible.

The construction of the customised equipment was carried out with the low-budget, homemade method. It was based on the scheme presented in the Figure 5.3. The novelty of the proposed project (in 2007) was that the device was wireless and easily portable due to its small dimensions compared to the electroencephalograms available on the market that time.

The analogue part of this dual-channel device (presented in Fig. 5.3) consisted of two active electrodes. The computing was based on micro-controller ATTINY2313. The used Bluetooth was BTM-112. The implementation of the wireless - Bluetooth-based technology had no influence on the device's work.

Figure 5.4 illustrates the electric circuit in the active electrode used in the project. The scheme was drawn in PSPICE (interface of the newest in year 2012 – 9.1 version – Fig. 5.5) application (student edition, current for 2007) and transformed into a scheme, which could be put onto a copper plate. The whole process of the whole copper-plate etching was described in detail in the further part of this sub-section.

## 5.4 Implementation – Using Customised Equipment

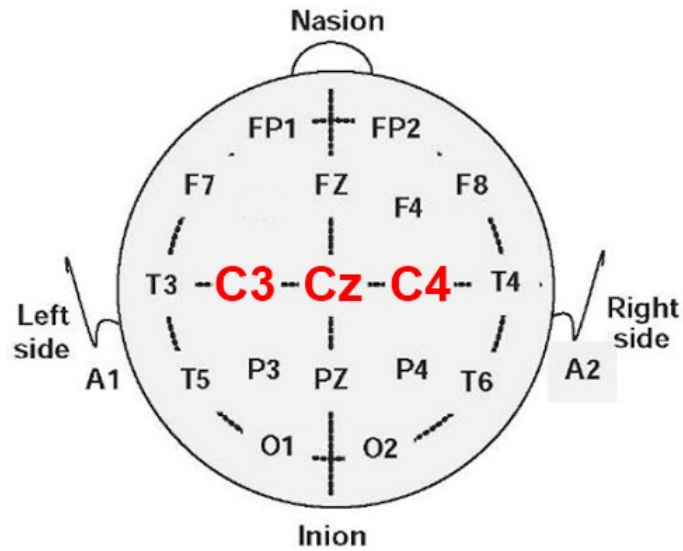


Figure 5.2: C3 and C4 - electrodes placement.

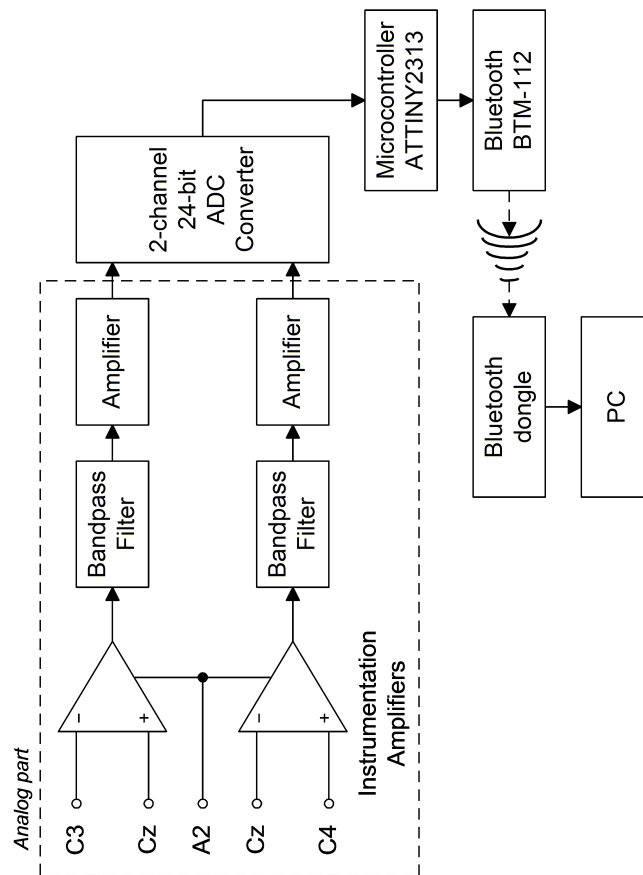
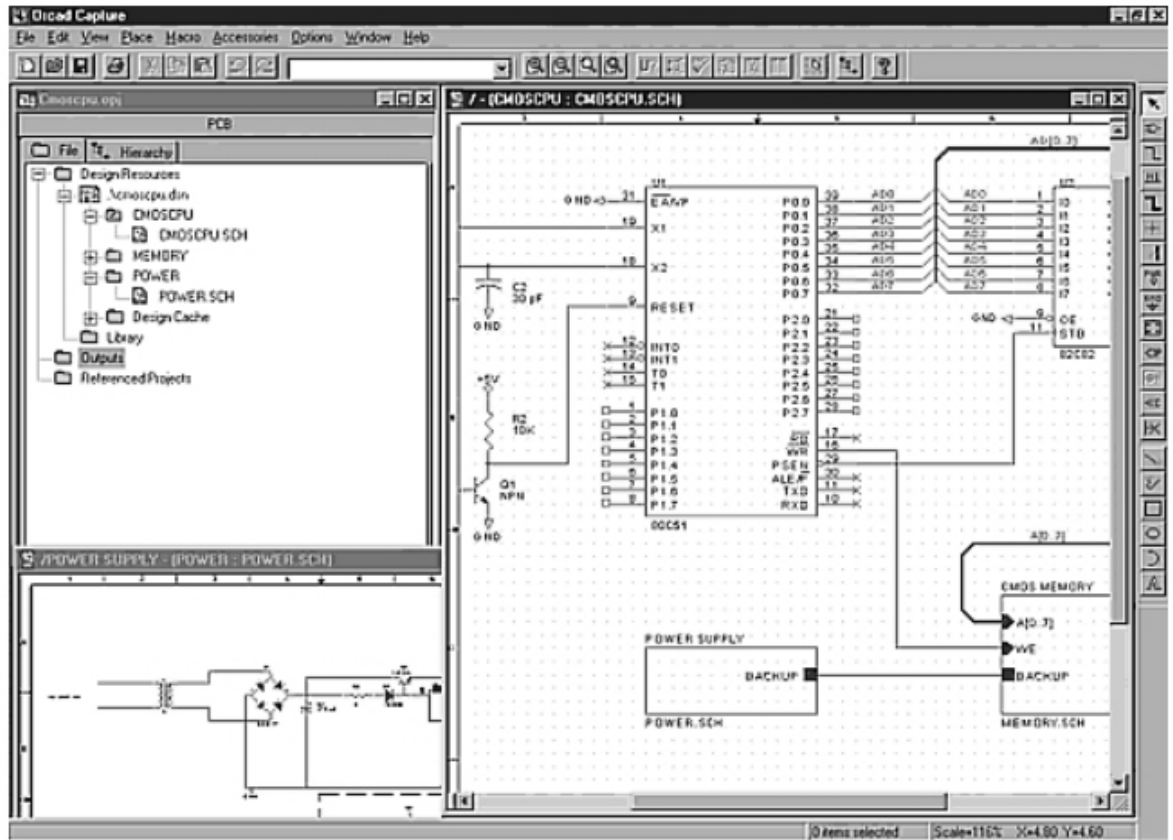


Figure 5.3: Customised equipment – basic scheme.



## 5.4 Implementation – Using Customised Equipment



**Figure 5.5:** PSPICE – interface [110].

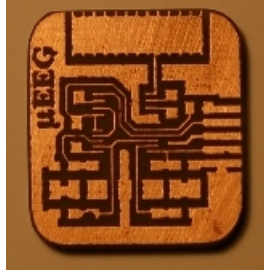
Figure 5.6 presented an unfinished active electrode copper plate. The plate has already been etched. All the tracts are clearly visible. The whole process of homemade copper plates etching is simple, but requires a lot of patience and accuracy.

The copper plate shown in Figure 5.6 was homemade. In order to carry out the etching the following components must be provided:

- copper plate,
- shiny, thick paper,
- solder,
- iron trichloride,

## 5.4 Implementation – Using Customised Equipment

---



**Figure 5.6:** Active electrode – etched copper plate.

- rosin,
- soldering,
- sandpaper – granulations 800-1300,
- iron,
- denaturant,
- dish washing liquid,
- laser printer,
- cotton cloth.

Copper plate has to be polished with a sandpaper in order to produce a smooth surface. When the surface is smooth enough it is necessary to wash out all contaminations with a dish washing liquid. The plate should not be touched. Later the copper plate should be wiped with a denaturant and left to dry out.

In the meantime the scheme of the circuit should be printed on a shiny thick paper with a laser printer. The quality of the print-out is very important. The printed-out scheme should be placed on the surface of the copper plate – the printed side should touch the copper-side. The plate with the paper on it should be covered with a clear cotton cloth and ironed. The ironing process should be repeated a few times. When the paper layer sticks to the copper plate – iron trichloride solution should be prepared.

Proportions for the solution are as follows – 300ml of boiling hot water on 50g of iron trichloride. The copper plate should be put to the solution for the

## 5.4 Implementation – Using Customised Equipment

---

etching process. The whole process may take between 45 minutes and 1.5 hour – depending on the size or thickness of the copper plate. Mixing and moving a bowl with the plate and the solution inside may accelerate the whole process.

When the copper plate is ready and the etched tracks are clearly visible – the plate should be lavishly cleaned with a warm water. This will stop the etching process. The plate should be ready for the further use and may look like like the one presented in the Figure 5.6. In case too much has been etched and the tracks are broken it can easily be repaired with soldering. Rosin will be used in case too much soldering was applied or for solder clearing purposes.

After all tracks are clearly visible (unbroken) – appropriate sub-assemblies can be soldered. In Figure 5.7 the control module with one electrode (in production phase) was presented.

Presented in Figure 5.8 was a simple mounting system. It was made with a soft, flexible wire in order to enable its fitting to various head shapes.

As it was mentioned above – the EEG device (Fig. 5.9) consisted of two active electrodes (Fig 5.10 and a control module (Fig. 5.11). One of the novelties was the implementation of combs that replaced a traditional (used that time – before 2007) electrodes – both active and passive. The combs improved skin contact and placing the device on subject’s head. It was important in case subject had long hairs. In numerous cases the long hair increased the appearance of external artifacts in recorded signal and decreased the recording quality. Figure 5.9 illustrates the customised device placed on long-haired female head.

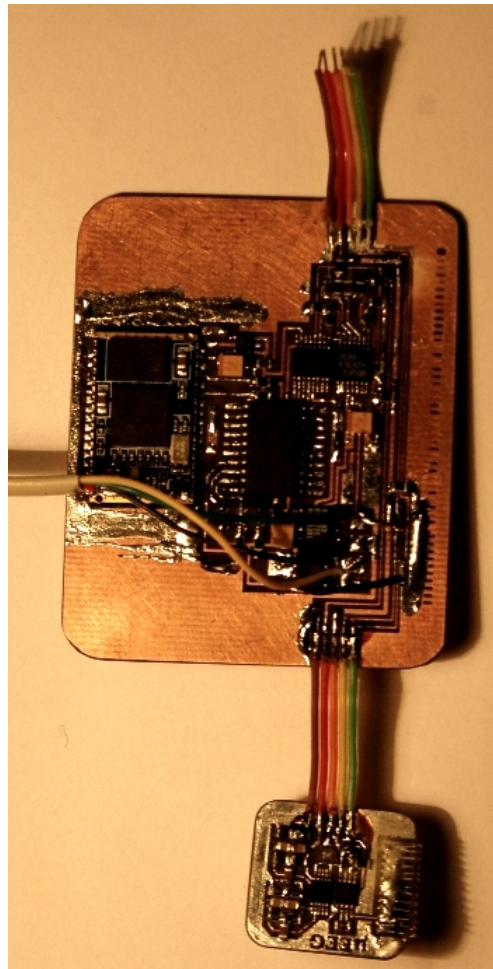
Each active electrode had an amplifier and a band-pass filter, that filtered out the frequency out of the desired range. The desired range for the study was between 8 and 12 Hz, what corresponds with the  $\alpha$ -waves range or (according to some sources and assumption established for this research purposes) –  $\mu$ -wave, which has similar parameters.

The analogue data recorder from the active electrode was converted to the digital form with a 24-bit ADC converter. In Figure 5.11 the control module of the device was presented. Its computing power was based on micro-controller ATTINY2313. It also had LDO – Linear Regulator. LDOs are usually implemented in systems that require a low-noise power source instead of a switching



## 5.4 Implementation – Using Customised Equipment

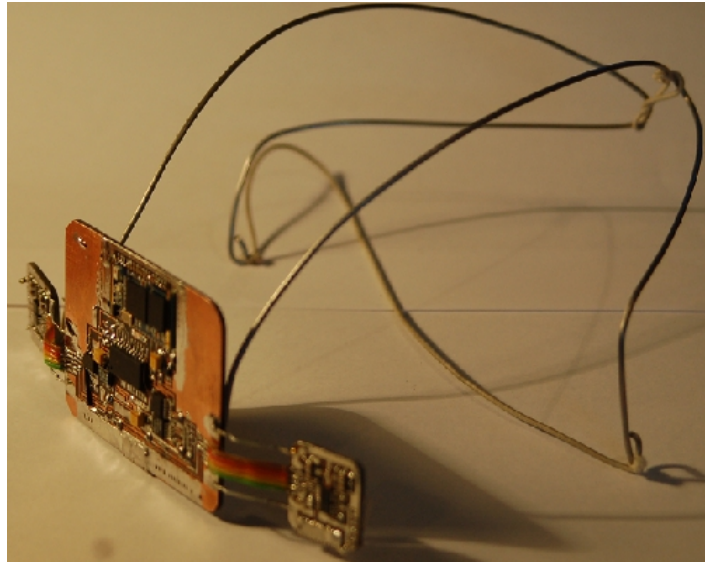
---



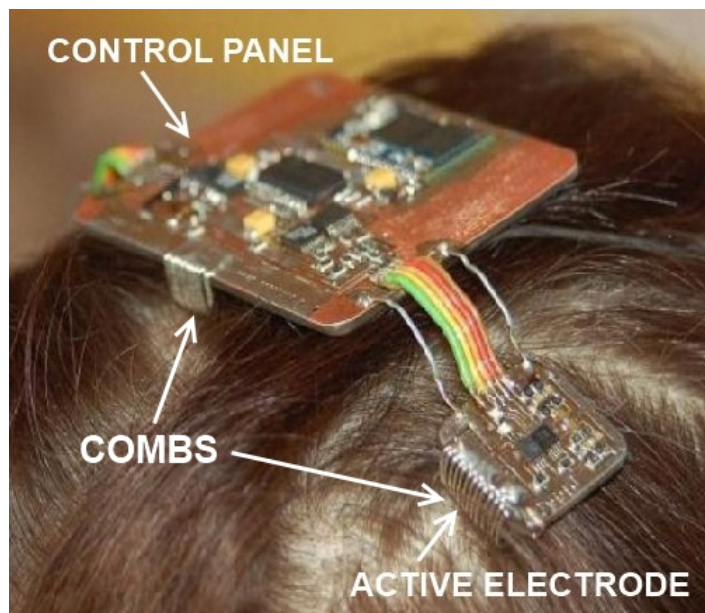
**Figure 5.7:** Customised, portable EEG – one electrode and the control module – in production phase.

## 5.4 Implementation – Using Customised Equipment

---



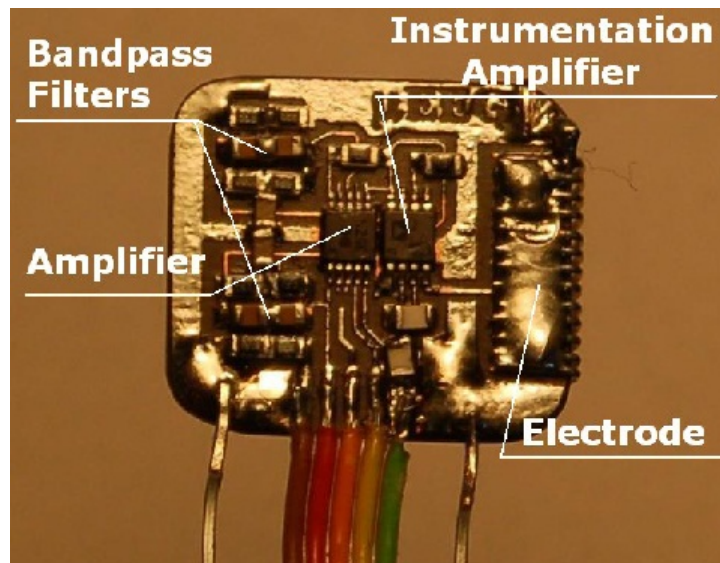
**Figure 5.8:** Customised EEG – mounting system.



**Figure 5.9:** The device placed on a female head.

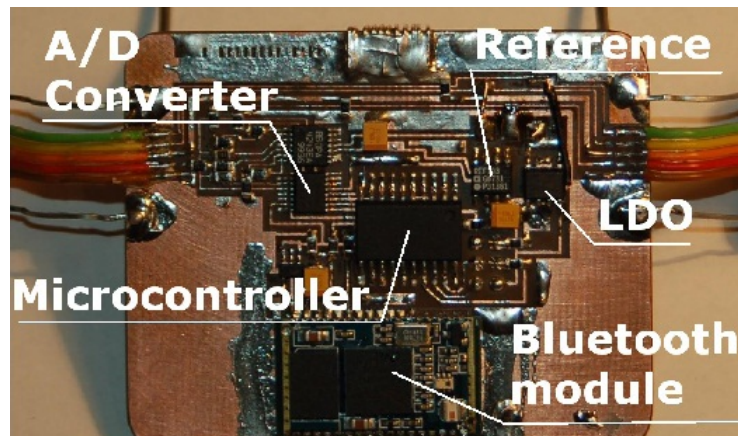
## 5.4 Implementation – Using Customised Equipment

---



**Figure 5.10:** Active electrode.

regulator that might affect the system's work. They are also a very good solution for portable and wireless applications. The data was to be transferred via Bluetooth, in that case – BTM-112.



**Figure 5.11:** Control module.

## 5.5 Data Acquisition – Using Customised Equipment

As mentioned above (in section – 'Research Methodology – Using Customised Equipment'(5.3)) initial tests, which were carried out, proved that the quality of the final design was not satisfactory and thus the accuracy was very low. The gained signals were of very poor quality and unsuitable for the further research purposes.

The very initial phase in data processing compromised work with EEGLAB toolbox for MATLAB. Interface of this free application was presented in Fig. 5.12. In 2007 the capabilities of the toolbox were very limited as it was difficult to analyse the data recorded from either the customised EEG or any other equipment, which was not listed as supported by the software. The toolbox was also excellent for analysis of their sample EEG data in order to start working with that source of data.

Figure 5.13 illustrates sample window with plot-components of EEG signal. This may be used for ICA analysis, which has not been implemented in this study, but is considered as a part for the further – post-doctoral research.

The EEG data processed during initial tests of the stage 1 phase of the study came from one of an open-source databases and was recorded during an experiment, of which basic scheme was illustrated in Figure 5.14. Subject was a left-handed, healthy male and the experiment relied on visual stimulation of the participant. The stimulus counted upon displaying two squares (on the left and right side – as illustrated in Fig. 5.14). Each square was marked with a different colour, left – red and right – blue. The subject had to press a button while appropriate square was displayed. The data was recorded from the two electrodes places on C3 and C4 positions.

## 5.5 Data Acquisition – Using Customised Equipment

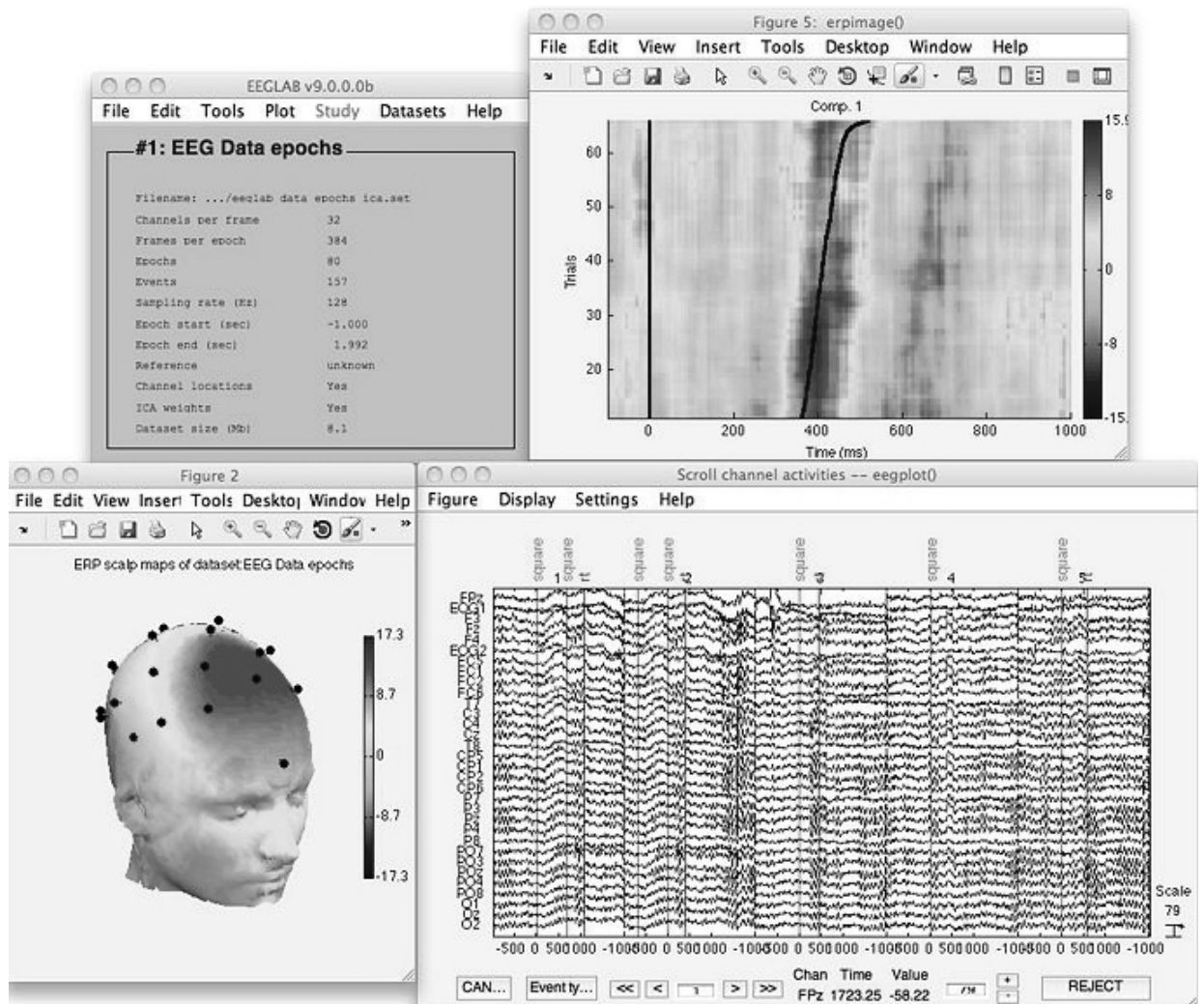


Figure 5.12: EEGLAB – interface [107].

## 5.5 Data Acquisition – Using Customised Equipment

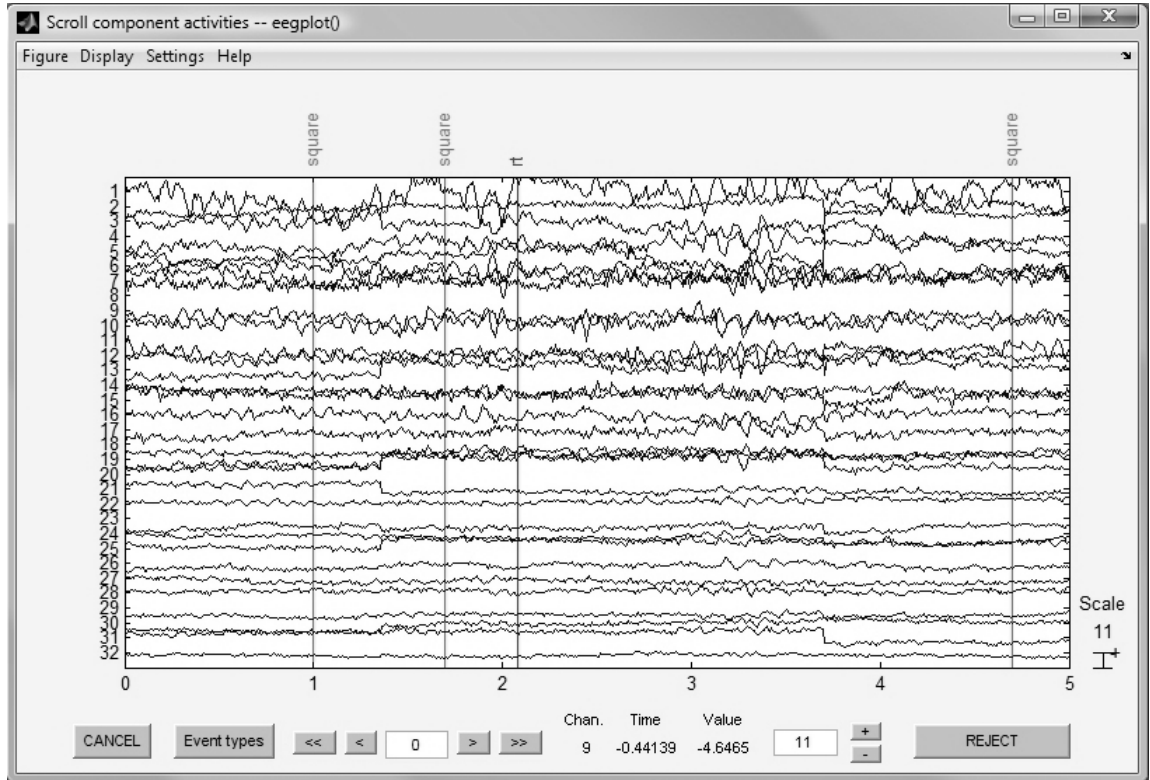


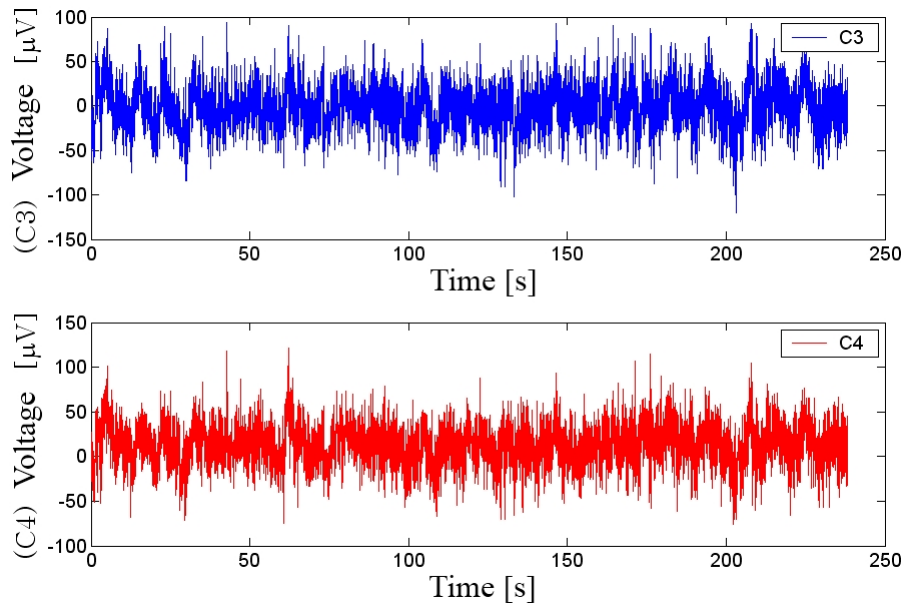
Figure 5.13: Scroll plot-components – sample window [107].



Figure 5.14: Experiment – basic scheme.

## 5.6 Results Evaluation – Using Customised Equipment

Signals gained during experiment described in the section – 'Data Acquisition – Using Customised Equipment'(5.5) were analysed with the implementation of traditional statistical methods and the application of the Morlet Wavelet. Figure 5.15 shows sample time progress in signal, registered from C3- (top) and C4- (bottom) electrodes.

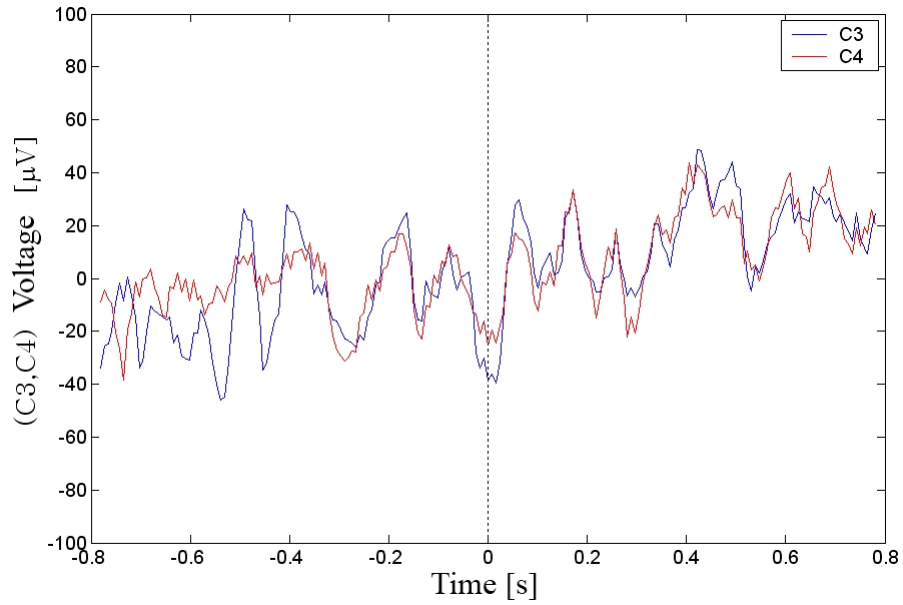


**Figure 5.15:** Sample time progress of EEG signals – C3 and C4 electrodes.

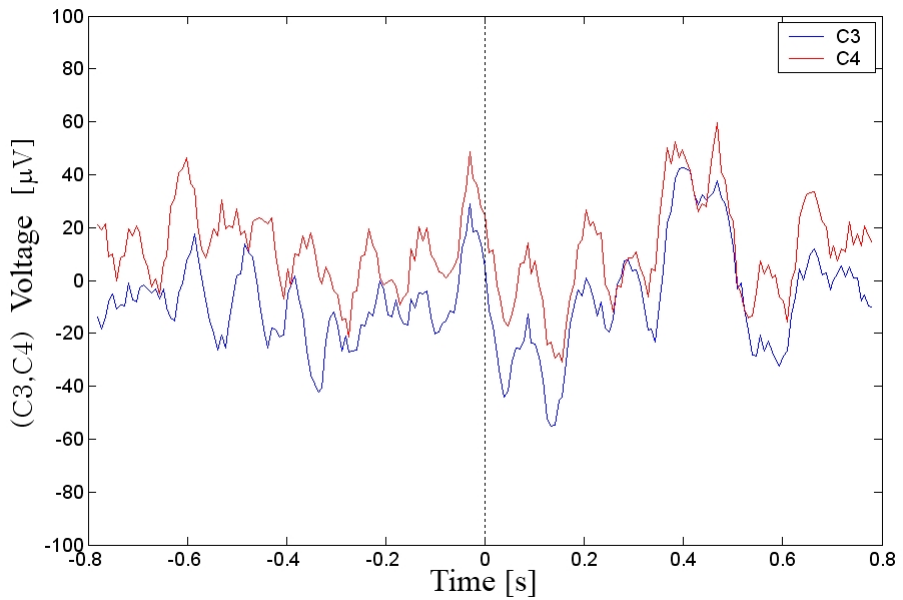
Figure 5.16 illustrates time progress of the analysed signal recorded during reaction to the stimulus 1, where a red square on the left side was displayed. Signal was registered from both electrodes – C3 (blue) and C4 (red).

However Figure 5.17 presents the time progress of the signal recorded during reaction to the stimulus 2, where a blue square appeared on the right side. Signal was also registered from the following electrodes – C3 (blue) and C4 (red).

## 5.6 Results Evaluation – Using Customised Equipment



**Figure 5.16:** Sample time progress of EEG signals – C3 and C4 electrodes – stimulus 1.

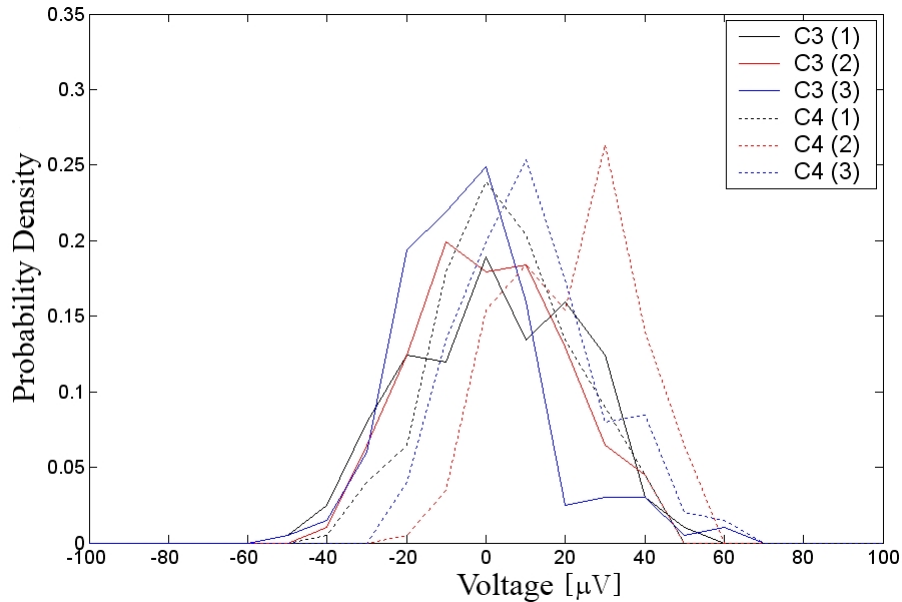


**Figure 5.17:** Sample time progress of EEG signals – C3 and C4 electrodes – stimulus 2.



## 5.6 Results Evaluation – Using Customised Equipment

Probability density function as a reaction to the stimulus 1 was presented in Figure 5.17, where the reaction to the stimulus 2 was illustrated in Figure 5.19.



**Figure 5.18:** Probability density function – stimulus 1.

The numbers in brackets in the key mean moments – 1, 2 and 3. Signals generated from the C3 electrode were plotted with a solid curve, where these from the C4 electrode – with a dotted one.

Figure 5.20 illustrates Cross-Covariance Function between signals gained from the C3 and C4 electrodes as a reaction to both stimuli. Cross-Covariance – or Cross-Correlation – is used in signal processing for similarity measuring purposes. It enables to find some unknown, interesting features in a signal through comparing it to the know one. It is commonly applied in pattern-recognition.

In the Figure 5.21 same correlation as in the Fig. 5.20 was presented, but in a normalised form.

Figure 5.22 presents spectral density of signal gained from C3 and C4 electrodes as result to the first stimulus – red square displayed on the left side, where Figure 5.23 illustrates the spectral density as a response to the second stimulus – blue square displayed on the right side.

In Figure 5.24 spectral density for the signal registered from the electrode C3

## 5.6 Results Evaluation – Using Customised Equipment

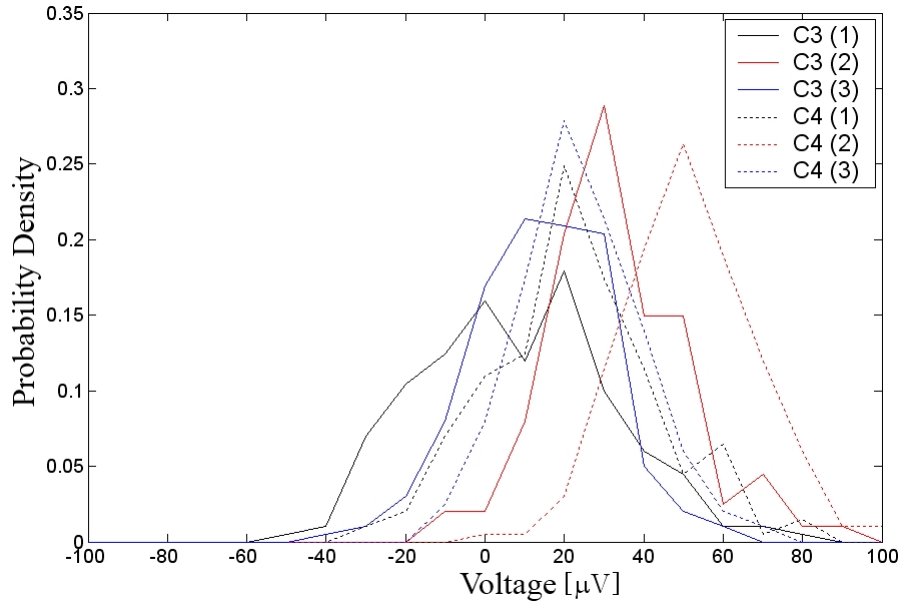


Figure 5.19: Probability density function – stimulus 2.

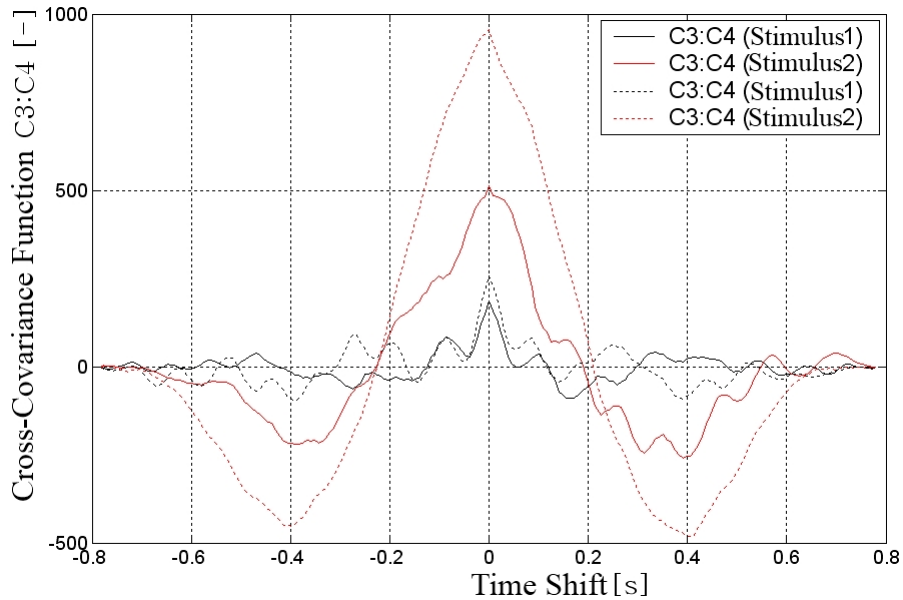
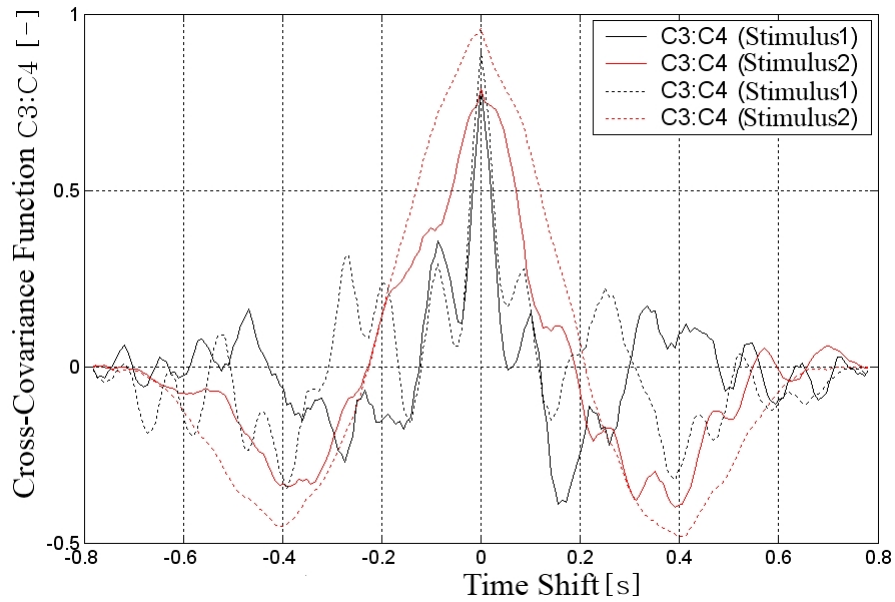
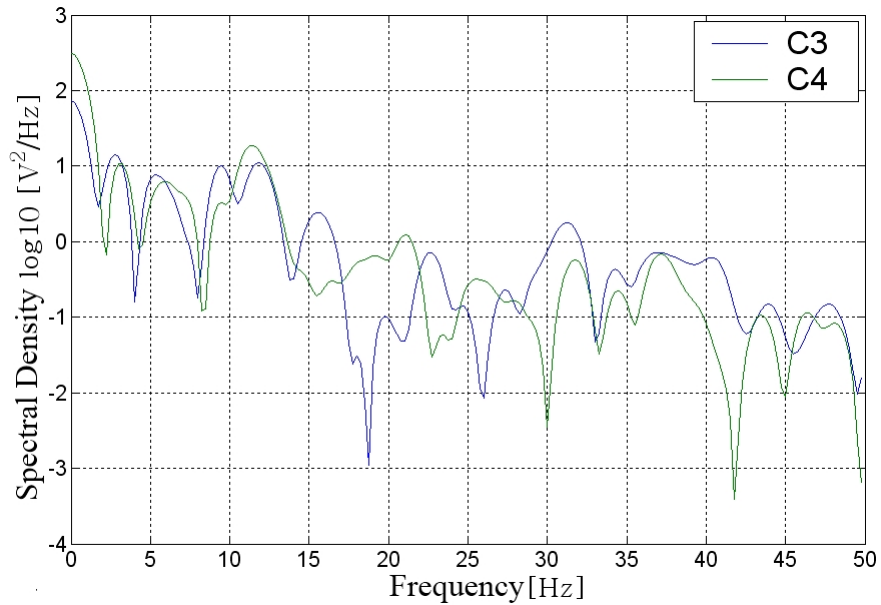


Figure 5.20: Cross-Covariance Function – C3 and C4 electrodes – both stimuli.

## 5.6 Results Evaluation – Using Customised Equipment



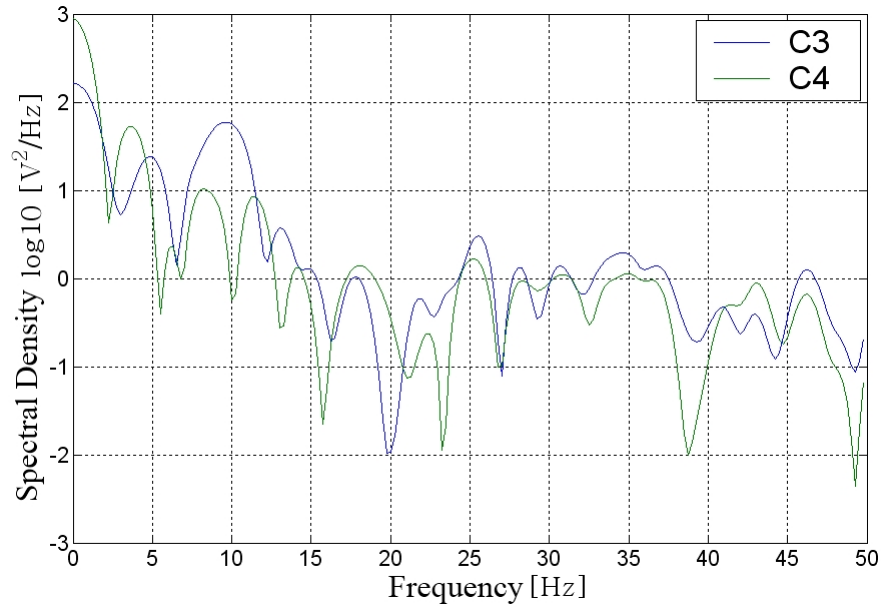
**Figure 5.21:** Cross-Covariance Function – C3 and C4 electrodes – both stimuli – normalised form.



**Figure 5.22:** Spectral Density – C3 and C4 electrodes – stimulus 1.

## 5.6 Results Evaluation – Using Customised Equipment

---



**Figure 5.23:** Spectral Density – C3 and C4 electrodes – stimulus 2.

as a reaction to both stimuli was presented and in the Figure 5.25 analogically the reaction to the two stimuli, but signal was recorded from the electrode C4.

Spectral density is used for statistical signal processing and may be successfully implemented for the bio-signal analysis purposes. It is a real positive real function of a frequency variable associated with a stationary stochastic process, or a deterministic function of time and measures the frequency content of a stochastic process and in order to help to identify periodicities.

## 5.6 Results Evaluation – Using Customised Equipment

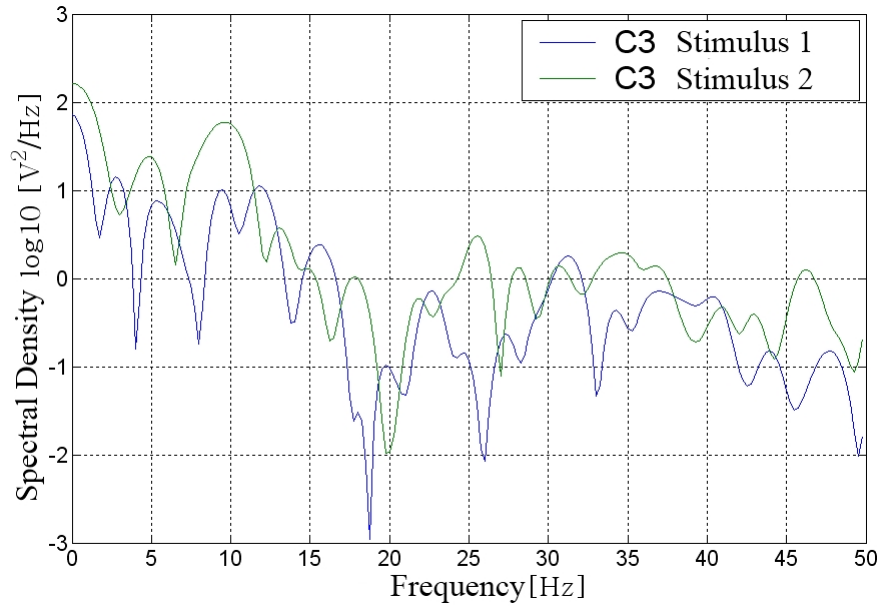


Figure 5.24: Spectral Density – C3 – both stimuli.

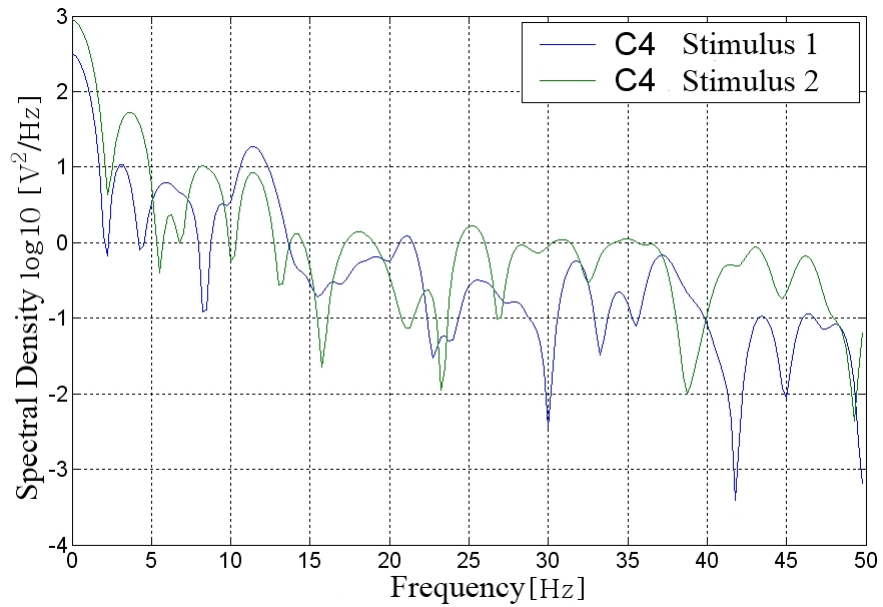
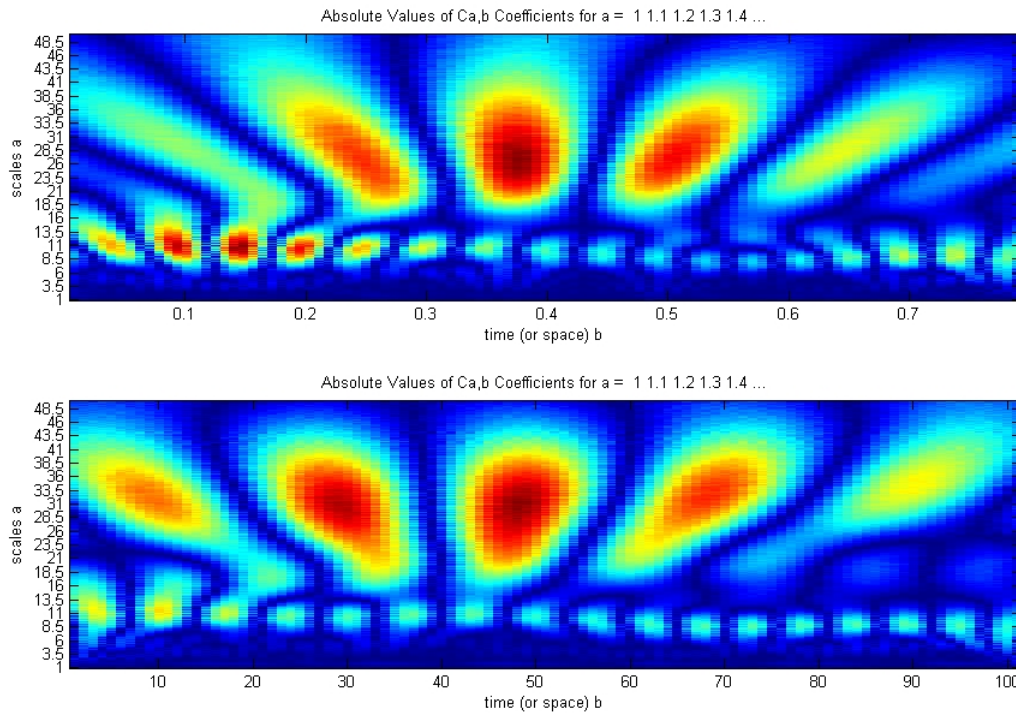


Figure 5.25: Spectral Density – C4 – both stimuli.

## 5.6 Results Evaluation – Using Customised Equipment

At that stage one of the research ideas was to use Wavelet Transform for the EEG signal processing. It was decided to use Morlet Wavelet for the spectral analysis purposes. In the Figure 5.26 – response to stimulus in electrodes C3 (top) and C4 (bottom) was presented. The response to the stimulus 1 is immediate, no latency was observed. In Figure 5.27 spectral analysis (also with the implementation of the Morlet Wavelet) was presented. Reaction to the stimulus 2 appears with latency, what has an impact on the method's efficiency.

The analysed frequency was between 8 and 12 Hz.



**Figure 5.26:** Wavelet Transform – Morlet – C3 and C4 – stimulus 1.

The possible application of Wavelet Transforms for the bio-signals processing or BCI purposes was in detail described in chapter – 'Signal Processing – Overview'(4), in subsection – 'Wavelet Systems'(4.1.3).

## 5.7 Discussion – Using Customised Equipment

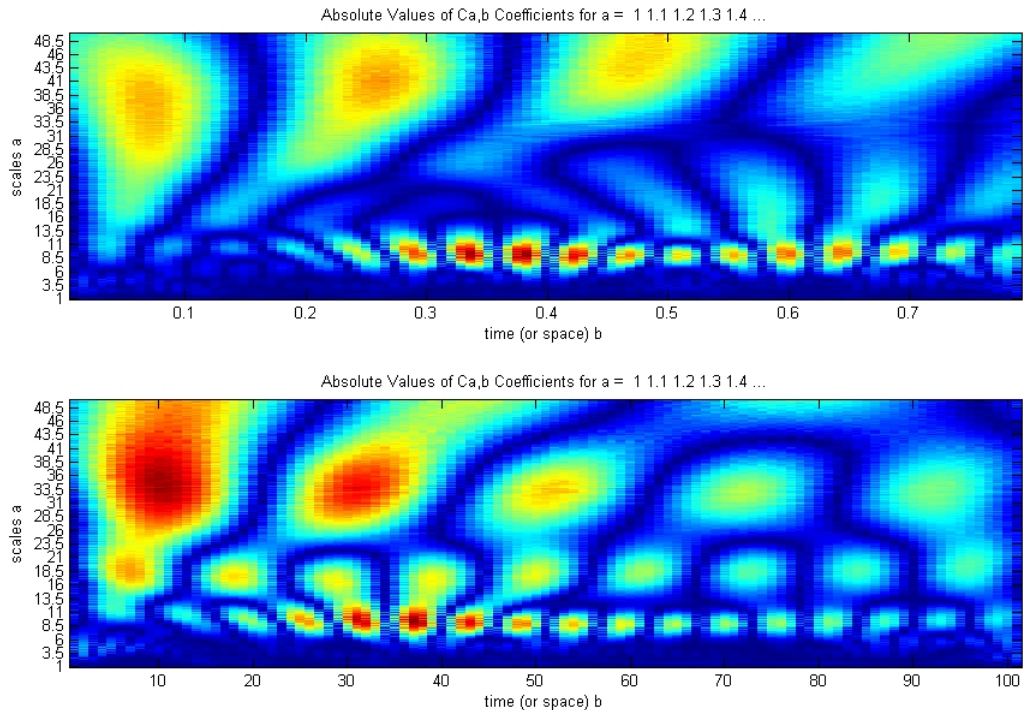


Figure 5.27: Wavelet Transform – Morlet – C3 and C4 – stimulus 2.

## 5.7 Discussion – Using Customised Equipment

The main goal of this study (Pilot Study Using Customised Equipment for BCI System) was to build customised EEG equipment. The device would consist of two channels placed on C3 and C4 positions. Final research (in Stage 3) has proven later that the channel location should be different. Tests conducted on the customised device proved that the quality of the final design was not satisfactory and thus the accuracy was very low. The gained signals were of very poor quality, which made the further analysis impossible.

It was also (wrongly) estimated that the information in time progress of signals gained from the electrodes C3 and C4 were able to contain the information about pictures (visual stimulus) observed by subject, what might have been used for the BCI design purposes. The implementation of the Morlet Wavelets proved that this method was not suitable for Brain-Computer Interfaces due to the latency appearance. In BCI systems very fast response is absolutely required.

The phase of the study, however not successfully completed, provided numer-

## 5.7 Discussion – Using Customised Equipment

---

ous crucial information regarding construction of customised equipment, electronic and bio-signals. The knowledge may be used for the further research purposes. It also proved that traditional statistical method were not suitable for the implementation of the embedded systems.



## 6

# Use of Clinical EEG Equipment for BCI System

In this chapter details of implementation of a professional medical electroencephalograph for the research purposes were presented. Due to the problems, which occurred while testing the customised equipment – described in detail in the previous chapter, it was decided to use professional medical equipment for data gaining purposes. This section will provide information on experiments and studies carried out with the use of two different electroencephalographs and the results obtained from that stage of the research.

### 6.1 Rationale for a Study – Using Clinical EEG Equipment

The decision about using appropriate, professional medical equipment arose as a result of problems occurring in the previous stage of the study. Initial tests conducted on the customised EEG proved its very low accuracy and as a result – signals of very poor quality. This resulted in impossible correct interpretation of the results and efficient data processing. Also the signal processing methodology – application of Wavelet Transform and traditional statistical methods – proved to be inefficient due to the latency occurrence and too high computing power

## 6.2 Objectives and Expected Results – Using Clinical EEG Equipment

---

requirements. There were two different medical electroencephalographs used for the study purposes.

Initial stage of the study has proven that both customised equipment and signal processing method did not give satisfactory results. This had led to the decision of conducting further part of the research with the use of professional medical equipment. For study purposes two different EEGs were applied – KT88-16 and Neurofax. The KT88-1016 belonged to the the institution, where the first stage of this research was carried out – the Opole University of Technology, Poland. Neurofax was facilitated by the Silesian University of Technology in Gliwice, also Poland – thanks to attentions of Professor Bernard Baron and Doctor Michal Lewandowski – from the Silesian University of Technology.

The attempts for finding efficient filtering method in order to extract desirable signal features were also presented in this section. This stage also contained description regarding finding an appropriate equipment not only for signal recording purposes, but also in order to obtain as much data as possible. The aim of this phase was also to carry on studies on building inexpensive, efficient, easy to use and portable Brain-Computer Interface, based on analysis of EEG signals recorded during imaginary movement. Range of analysed signal was still between 8 and 12 Hz – and that range corresponds with the frequency band of  $\mu$ -waves.

## 6.2 Objectives and Expected Results – Using Clinical EEG Equipment

Below is in short specified the main objectives related to the second stage of the research:

- Update literature review in area of studies on Brain-Computer Interfaces and EEG signals processing techniques.
- Improve knowledge about EEG signal processing techniques.
- Conduct research about various medical EEG devices.

- Collect data from various medical electroencephalographs.
- Find efficient pattern-extraction method.
- Carry out spectral analysis on recorded data.
- Analyse and discuss the results about using professional medical equipment for BCI purposes.

## 6.3 Research Methodology – Using Clinical EEG Equipment

The above specified objective – literature review in area of bio-signals processing (particularly EEG) and Brain-Computer Interfaces had to be updated. As this area of study is on constantly growing interest, the progress in this research field has remarkably increased. Statistical signal processing techniques have been replaced by more sophisticated methods. It resulted in increased efficiency in proposed Brain-Computer Interfaces. This was in detail described in chapter – ‘Literature Review’(2).

Problems with the customised device and its low accuracy have led to the decision of using professional equipment for data collecting purposes. Two different electroencephalographs have been used – KT88-16 and Neurofax. KT88-1016 produced by a Chinese Company – Contec Medical Systems, consisted of 16 passive electrodes. Neurofax is more advanced (and expensive) device with 32 channels.

Collecting data from various equipments enabled to test filtering methods on signals registered with inter alia different frequencies. It also made conducted research more challenging and interesting. The efficient pattern-recognition has not been found at this stage, but it gave more experience and knowledge on EEG signals processing. It is also important that according to International Federation of Clinical Neurophysiology – sampling frequency should be at least 200 Hz and a product of either 50 or 64 [111, 112].

Spectral analysis has been carried out and the results have been presented in the further part of this chapter.

## 6.3 Research Methodology – Using Clinical EEG Equipment

---

Conducted research has proven that the signals were recorded with higher accuracy, although it made the medical equipment unsuitable for the research purposes. Medical devices recorded raw signals, with no pre-processing, thus the EEG source was noisy with presence of various external and internal artifacts. The signals were recorded (still with a wrong approach) from the electrodes placed on C3 and C3 positions.

The data collected during the experiments with the implementation of medical EEGs was unsuitable for the study purposes. The devices also did not meet the requirement of portability.

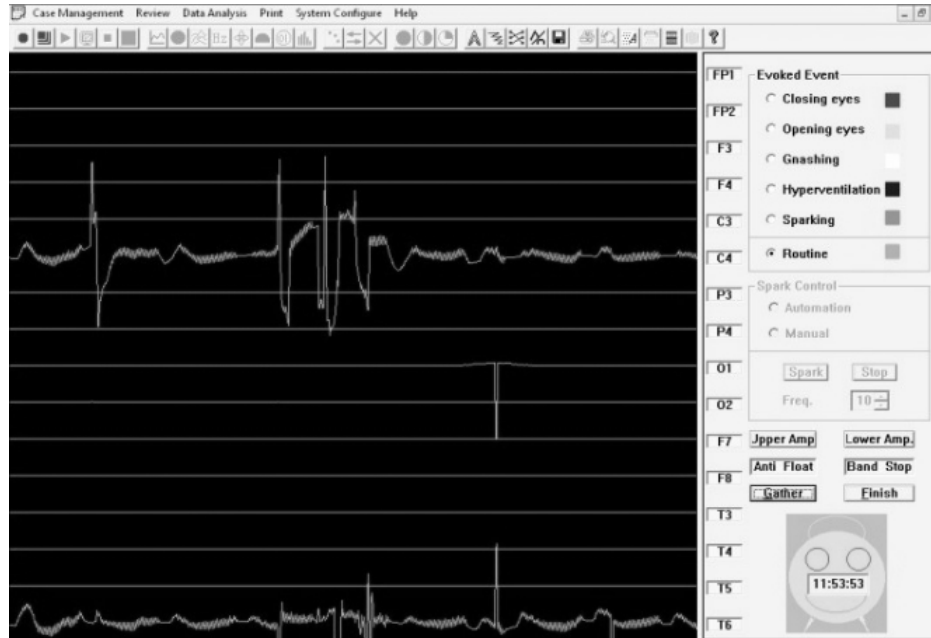
### 6.3.1 Implementation – Using Clinical EEG Equipment

The first part of experiments conducted for this research purposes were carried out KT88-1016 EEG – inexpensive 16-channel electroencephalograph. Despite the very low price – \$750 (the price paid in 2009, now it is between \$800 and \$1200) – the device was designed for clinical use purposes [113, 114]. In Figure 6.1 was presented the device, where Figure 6.2 illustrates software interface during sample signal recording.



**Figure 6.1:** KT88-1016 – device [113].

### 6.3 Research Methodology – Using Clinical EEG Equipment



**Figure 6.2:** KT88-1016 – software interface [114].

Software provided with KT88-1016 has very limited functionality and it affects its possible application for Brain-Computer Interface purposes. The recorded data is being saved in '.eeg' format. There was a trouble with this file format as it seemed not be supported by MATLAB. Below is a code for a very basic '.eeg' to '.edf' converter. Despite its simplicity – it worked.

```
clear all;
load ola.EEG; %sample file '*.eeg'
fid = fopen('0000001.EEG','r');
c=fread(fid,1);
```

Data was recorded with the sampling frequency – 100 Hz, which is very low according to the recommendations of International Federation of Clinical Neurophysiology, which advises the record at minimum 200 Hz frequency [111, 112]. Second device used for EEG data collection was Neurofax – professional and expensive medical device, able to record signals with the sampling frequency of 250 Hz. The exact model of the Neurofax is unknown. Electroencephalograph was presented in Figure 6.3 [115].



**Figure 6.3:** Neurofax – device [115].

Neurofax saves files in '.edf' format. The file format is not compatible with MATLAB, but could easily be converted in EEGLAB into '.mat' file. The ability of easy and quick conversion of '.edf' files into '.mat' format has made the work with both devices easier and enabled to use the data collected from as well KT88-1016 as Neurofax. In both cases – only two electrodes – C3 and C4 – were implemented.

## 6.4 Data Acquisition – Using Clinical EEG Equipment

During the experiments carried out with the application of the above, only two channels were used – C3 and C4. This was enough for the research purposes and enabled to record the signal from both cerebral hemispheres. Overall six series of experiments were conducted. Two participants took part in the study – female, aged 29, right-handed hereinafter called 'Subject A', and – male, aged 22 also right-handed hereinafter called 'Subject B'. In Figure 6.4 'Subject A' was presented, where Figure 6.5 shows 'Subject B'.

As it was mentioned above, the whole experiment consisted of two parts – depending on location and equipment used. The first series was conducted with the participation of the 'Subject B' and application of KT88-1016 at the Opole

## 6.4 Data Acquisition – Using Clinical EEG Equipment

---



**Figure 6.4:** 'Subject A' during experiment.

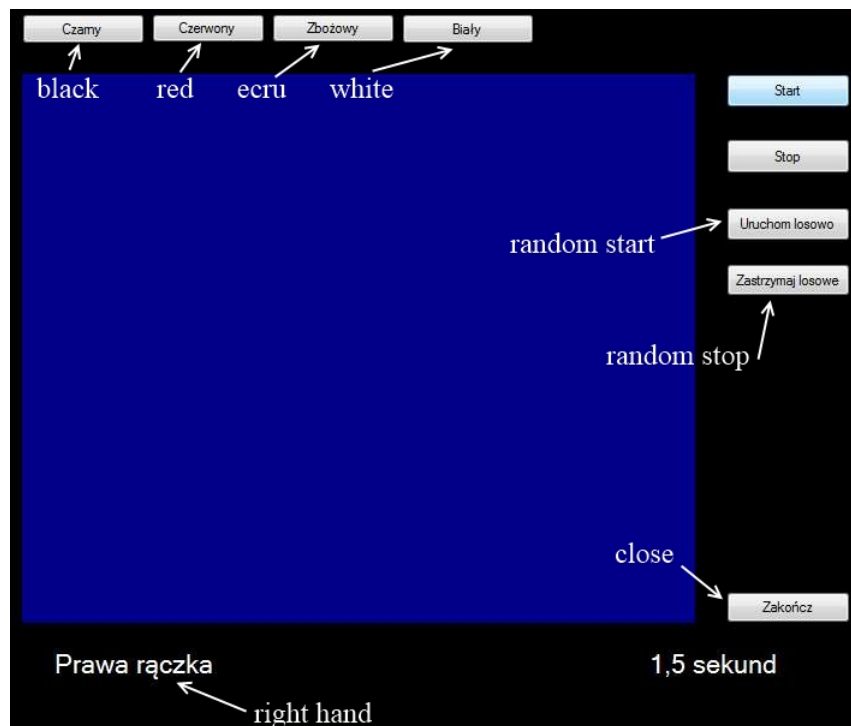


**Figure 6.5:** 'Subject B' during experiment.

## 6.4 Data Acquisition – Using Clinical EEG Equipment

University of Technology. The second part took place at the Silesian University of Technology in Gliwice, with the participation of 'Subject A'. The data was collected with the Neurofax equipment.

In the Figure 6.6 screen-shot of window used for visual stimulation of both subjects has been presented.



**Figure 6.6:** Visual stimulus – screen-shot.

The experiments relied on moving the right or left hand after the appropriate square was displayed the screen of computer – blue (right hand) or red (left hand). This experiment was similar to the one described in previous chapter – squares appeared randomly or regularly (in every 10 seconds).

Double basic filtering was used for the study purposes and the desired frequency was again the range of  $\mu$ -waves – 8-12 Hz. The filter was designed with the use of FDA tool in MATLAB (GUI presented in Fig. 6.7). FDA tool is an easy and quick tool for design and implementation of various simple filters. It is ideal for conduction initial tests in order to check the efficiency of particular filters.



## 6.4 Data Acquisition – Using Clinical EEG Equipment

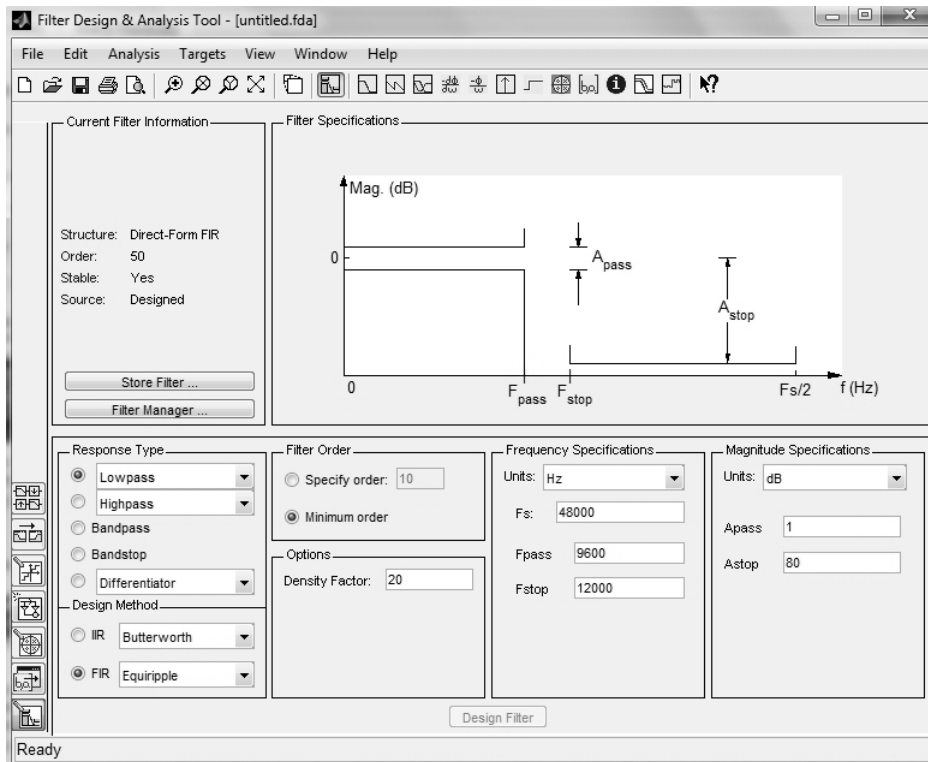
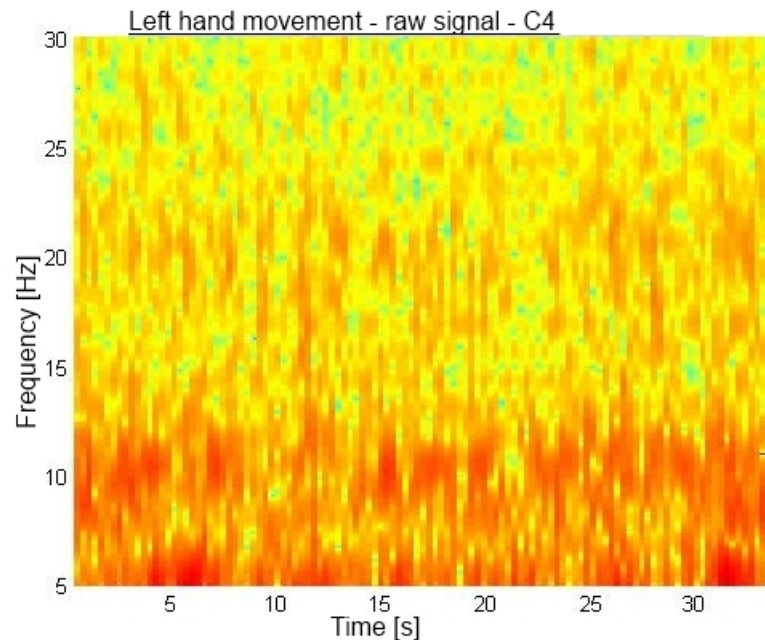


Figure 6.7: FDA tool – user interface.

## 6.5 Results Evaluation – Using Clinical EEG Equipment

The signals presented below were gathered from the Neurofax device. Sampling frequency was 250 Hz, which was high. Spectrograms of both – raw and filtered signals – were also presented in this section.

In Figure 6.8 a spectrogram of a raw (completely unprocessed) signal, recorded with the sampling frequency – 250 Hz, was presented. The signal was gathered from the C4 electrode during – imaginary left-hand movement.



**Figure 6.8:** Raw signal recorded from C4 electrode – left hand movement.

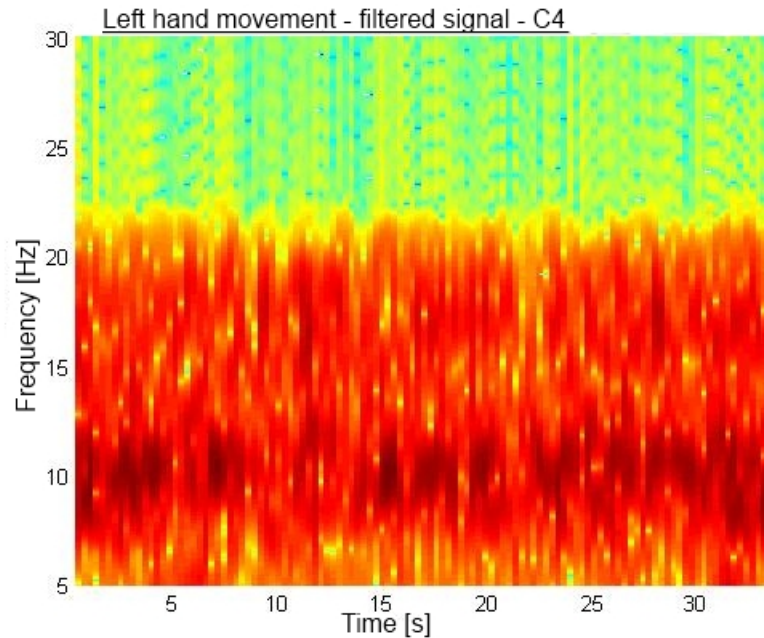
Figure 6.9 illustrated the filtered signal from Fig. 6.9.

Signals presented in this subsection were filtered with a simple band-pass filter generated with the FDA tool. The code of the filter was presented below:

```

Fs = 250;
Fstop1 = 8;           % First Stopband Frequency
Fpass1 = 10;         % First Passband Frequency
Fpass2 = 10;         % Second Passband Frequency
    
```

## 6.5 Results Evaluation – Using Clinical EEG Equipment



**Figure 6.9:** Filtered signal recorded from C4 electrode – left hand movement.

```
Fstop2 = 12;           % Second Stopband Frequency
Dstop1 = 0.001;       % First Stopband Attenuation
Dpass  = 0.057501127785; % Passband Ripple
Dstop2 = 0.0001;     % Second Stopband Attenuation
dens    = 20;         % Density Factor
[N, Fo, Ao, W] = firpmord([Fstop1 Fpass1 Fpass2 Fstop2]/(Fs/2), [0 1 ...
                          0], [Dstop1 Dpass Dstop2]);
b = firpm(N, Fo, Ao, W, {dens});
Hd = dfilt.dffir(b);
```

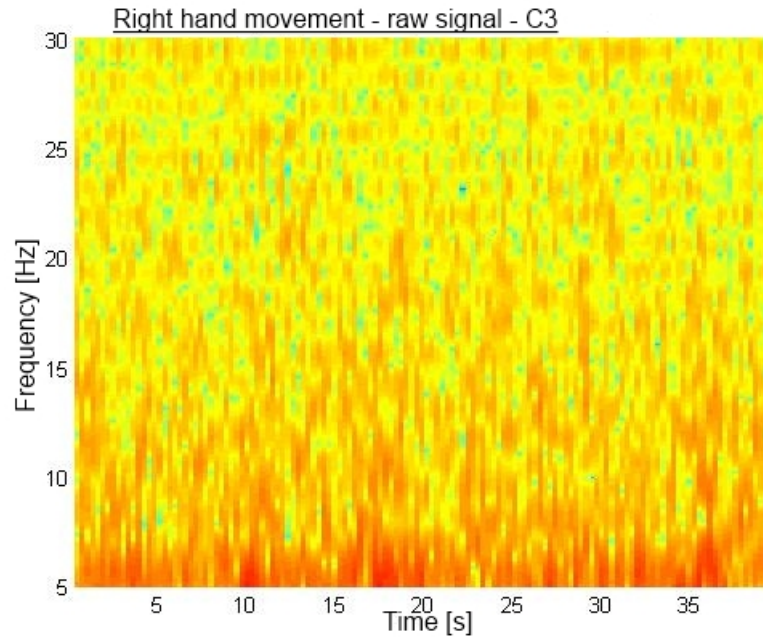
Double filtration was used in order to reduce the latency in signal processing.

Figures 6.10 and 6.11 – show analogically the signal (raw – Fig. 6.10 and filtered – Fig. 6.11) generated during imaginary right hand movement, recorded from the electrode placed on C3 position.

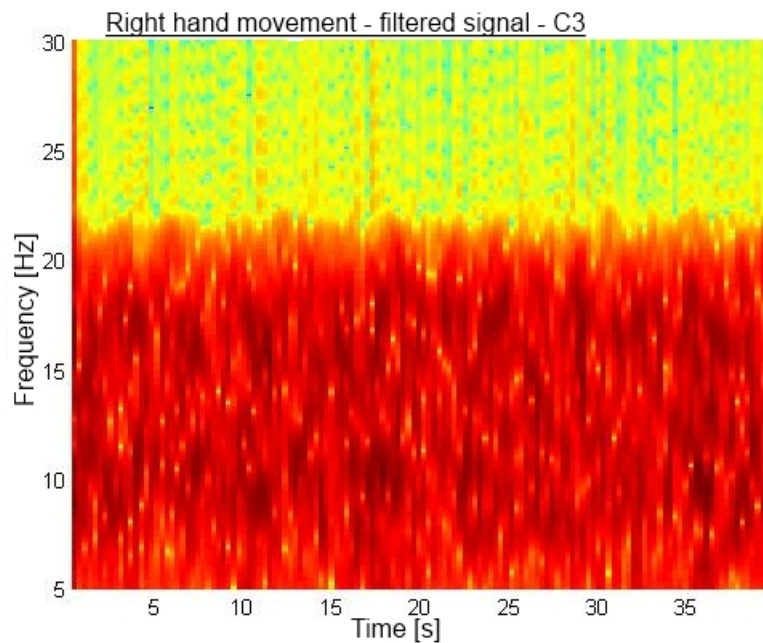
The gathered signals were noised and over-hyped. At that stage of the research it was very hard to find any patterns.

## 6.5 Results Evaluation – Using Clinical EEG Equipment

---



**Figure 6.10:** Raw signal recorded from C3 electrode – right hand movement.



**Figure 6.11:** Raw signal recorded from C3 electrode – right hand movement.

### 6.6 Discussion – Using Clinical EEG Equipment

The device used in previous stage of this study was inappropriate due to its very low accuracy, which resulted in poor quality signals. Using professional, medical equipment was supposed to enable good quality recording of EEG signals. Unfortunately – despite using band-pass filtering – the obtained signals were over-hyped and very noisy.

The reason for this was that medical equipment is very sensitive and was able to register external artifacts. It is usually used in quiet, muffled rooms, what makes it impossible to apply in similar to real-life conditions. The device is not portable, which also makes it impossible for the Brain-Computer Interface implementation.

Carried out research not only provided more information about EEG data analysis, but also proved that sound stimuli implementation is unsuitable for research purposes. It also proved that double filtering used in off-line analysis can be an efficient solution due to decreased latency.

KT88-1016 used in this stage, although designed for clinical use, had in 2008-2009 very limited software functionality. However it is possible to use it, with updated software (Fig. 6.12) for the further, post-doctoral research purposes.

## 6.6 Discussion – Using Clinical EEG Equipment

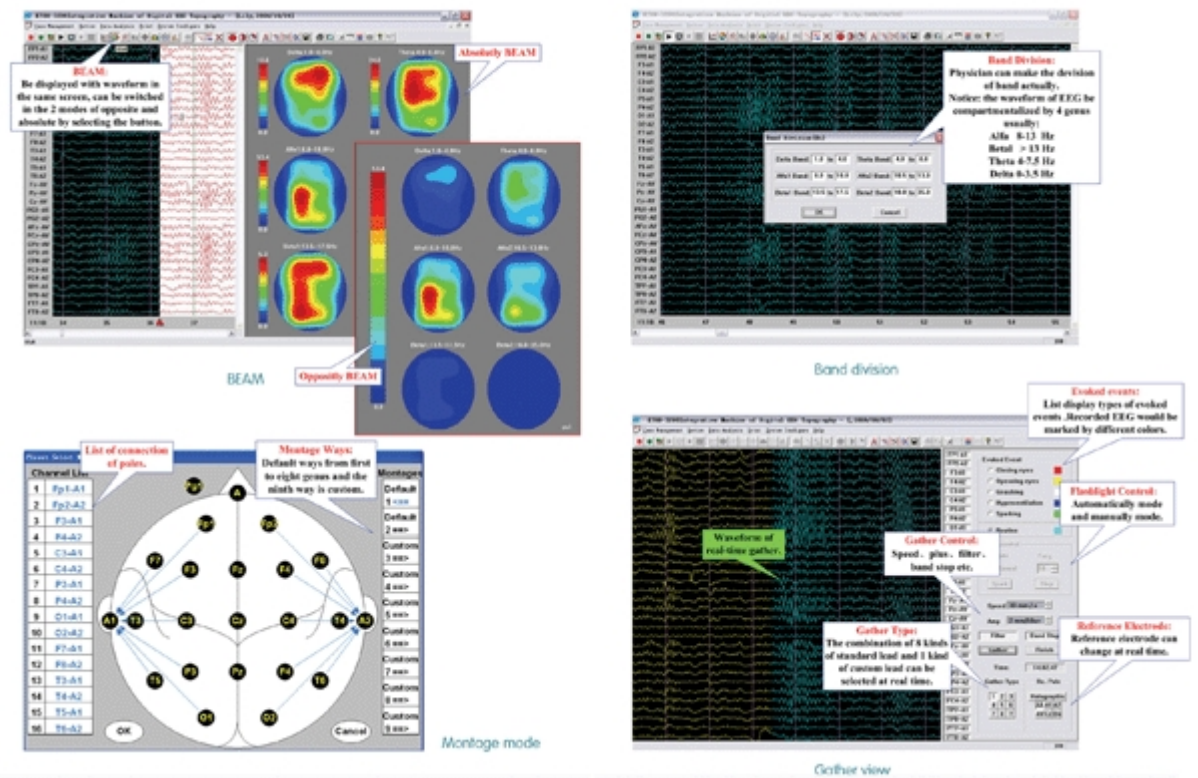


Figure 6.12: Improved KT88-1016 software interface [113].

# 7

## Use of Emotiv Headset for BCI System

In this chapter details of the final stage of this project was in depth presented. This part of the thesis contains detailed description of the efficient pattern-recognition algorithm (crucial for embedded systems) implemented within the demonstrator applications. In this – final stage – implementation of an inexpensive Emotiv EPOC headset with the application of embedded system platform was presented together with the novelty of used approach.

### 7.1 Rationale for a Study – Using Emotiv Headset

Motivation for using Emotiv EPOC headset was both – its price and availability on an open market. It was also important that it was designed for gaming purposes and therefore to use in real-life, noisy conditions.

The Emotiv EPOC headset is very easily available and inexpensive alternative to the traditional electroencephalograph. Electrodes are placed according to the 10-20 systems. The choice of the used electrodes for the research purposes was caused by the location of the brain activity during imaginary movement [78, 116, 117].

## 7.2 Objectives and Expected Results – Using Emotiv Headset

- Update literature review in area of possible Emotiv EPOC headset implementation.
- Improve knowledge about EEG signal processing techniques.
- Conduct experiments using Emotiv EPOC headset.
- Collect EEG data from Emotiv EPOC headset.
- Implement obtained EEG data for control purposes.
- Analyse and discuss the results about using Emotiv EPOC headset for BCI purposes.

## 7.3 Research Methodology – Using Emotiv Headset

Thorough literature review done on possible Emotiv EPOC headset implementation has been presented in Chapter – 'Literature Review'(2), Section – 'The Newest Trends in Brain-Computer Interfaces'(2.3) in Subsection – 'Emotiv-based Brain-Computer Interfaces'(2.3.1). The knowledge about using various signal processing techniques has been constantly improved. Collected data was analysed and the results were presented in the further part of this section.

Collected data was implemented for control purposes with the application of embedded platform, which simulated external environment. Results have been as well presented as discussed.

## 7.4 Implementation – Using Emotiv Headset

For the research purposes Emotiv EPOC headset, which consisted of 16 electrodes, but only 14 placed on scale was used in this study. The sampling rate of the device is 128 [Hz] and the bandwidth is between 0.2 and 45 [Hz] [31, 33].



Emotiv headset can also be successfully used for user emotions recognition, enabling a possible wider use as opposed to a traditional clinical EEG-equipment [30]. The device has three types of controls – EEG, EMG and Gyroscope. The device has fewer scalp contacts than a typical, expensive, professional device. It also has potentially less accuracy than a typical EEG [29, 32].

In Figure 7.1 the Emotiv EPOC headset was presented [31].



**Figure 7.1:** Emotiv EPOC headset [31].

Emotiv EPOC provides wireless USB connector and has relatively good battery life – up to 12 hours work [121]. The signals recorded with Emotiv EPOC headset are quite noisy [34].

### 7.4.1 Decision-making Process Based on Signal Processing

Equation (7.1) shows the mathematical interpretation of the chosen solution. The closeness of a tested bio-signal to its reference pattern (or model) is assessed by an accuracy measure related to the minimisation criterion,

$$\epsilon = \frac{(1 - \alpha)}{N} \sum_{k=0}^{N-1} [\tilde{s}_i(kT_s) - \tilde{p}_i(kT_s)]^2 + \frac{\alpha}{M} \sum_{l=0}^{M-1} \left[ \left| \tilde{S}_j(lf_s) \right| - \left| \tilde{P}_j(lf_s) \right| \right]^2 \quad (7.1)$$

## 7.4 Implementation – Using Emotiv Headset

---

where  $t = kT_s$  is the discrete time ( $k = 0, 1, \dots, N - 1$ ),  $\tilde{s}_i(kT_s)$  and  $\tilde{p}_i(kT_s)$ ,  $i = 1, \dots, r$ , are the discrete time representations of the  $i$ th signal and its pattern (or model), respectively, sampled at the frequency  $F_s = \frac{1}{T_s}$ , where  $T_s$  is the sampling interval,  $|\tilde{S}_j(lf_s)|$  and  $|\tilde{P}_j(lf_s)|$  are the single-sided amplitude spectra of  $\tilde{s}_i(kT_s)$  and  $\tilde{p}_i(kT_s)$ , respectively, with  $f_s$  being the frequency step-related to (but not necessarily equal) to  $F_s$ .

In Equations (7.1)  $\tilde{s}_i$  and  $\tilde{p}_i$  are normalised values for respectively signal  $s_i$  and pattern  $p_i$  calculated as:

$$\begin{cases} \tilde{s}_i = \frac{s_i}{q}; \\ \tilde{p}_i = \frac{p_i}{q}; \end{cases}$$

where  $q = \max(s_i, p_i)$ . Similarly,

$$\begin{cases} \tilde{S}_j = \frac{S_j}{w}; \\ \tilde{P}_j = \frac{P_j}{w}; \end{cases}$$

where  $w = \max(S_j, P_j)$ . Normalisation guaranties that  $(\tilde{s}_i, \tilde{p}_i, \tilde{S}_j, \tilde{P}_j) \in [0, 1]$  and thus the  $\epsilon$  values always belong to  $[0, 1]$ .

There are two components of Equation (7.1) to analyse. The  $\alpha$ -weighted difference between the pattern and the signal is set up for both domains - the time domain and the frequency domain. In case the signal is very noisy, then – as a result – its time-domain representation may not be very useful for the research purposes. In this case the  $\alpha$  coefficient should be set to the value '1' or very close to '1', so that only the frequency domain component would be taken into account.

Typically – as the 'best' solution – the value of the  $\alpha$  coefficient should be set to 0.5, which means that both components are equally important. The novelty of the diagnostic (or pattern recognition) approach adopted here is an application of a threshold imposed on  $\epsilon$  which was obtained from Equation (7.1), enabling to make decisions on the quality of pattern recognition.

A diagnosis is based on the decision-making process, which is binary:

$$d = \begin{cases} 0 & \text{if } \epsilon \leq \text{threshold} \\ 1 & \text{if } \epsilon > \text{threshold} \end{cases} \quad (7.2)$$

with the decision  $d = 0$  meaning a good agreement of the signal and its pattern. Of course, various values of the threshold will be tested. Possible use of a ternary decision process, with a decision uncertainty zone included, has not been found in our experiments to essentially affect the quality of the diagnostics of bio-signals.

It is finally worth mentioning that the adopted tools for signal processing could possibly be more advanced. However, more sophisticated methods mentioned in Chapter – ‘Signal Processing – Overview’(4) might lead to prohibitive computational burdens, in particular in the embedded system environment selected owing to the low-cost implementation prerequisite.

### 7.4.2 Implemented Applications

The main aim of the client-server application is the visualisation and simulation of an external environment, such as wheel-chair or toy. The scheme of the application was shown in Figure 7.2. This application had to do these three tasks: visualisation, simulation and control.

The server application was responsible for reading the data from the Emotiv EPOC headset. The application was written in C# and enabled communication with the client application.

The client application was written in the C++. It was implemented on the board TS-7260 with an embedded system. The TS-7260 enables the simulation of an external environment. The TS-7260 is compact Single Board Computer (SBC) with CPU – Cirrus EP9302 ARM9. The processor is ARM920T with the frequency of 200 Hz. The board has also UNIX/Linux – Debian operating system boot from an SD card [118]. Figure 7.3 presents TS-7260 board.

As it was mentioned above and shown in Figure 7.2 – the board was connected with the server via TCP/IP. The server application was written in C# and was on PC computer. The client application was connected with MATLAB. The pattern recognition process took place in MATLAB application, which enabled

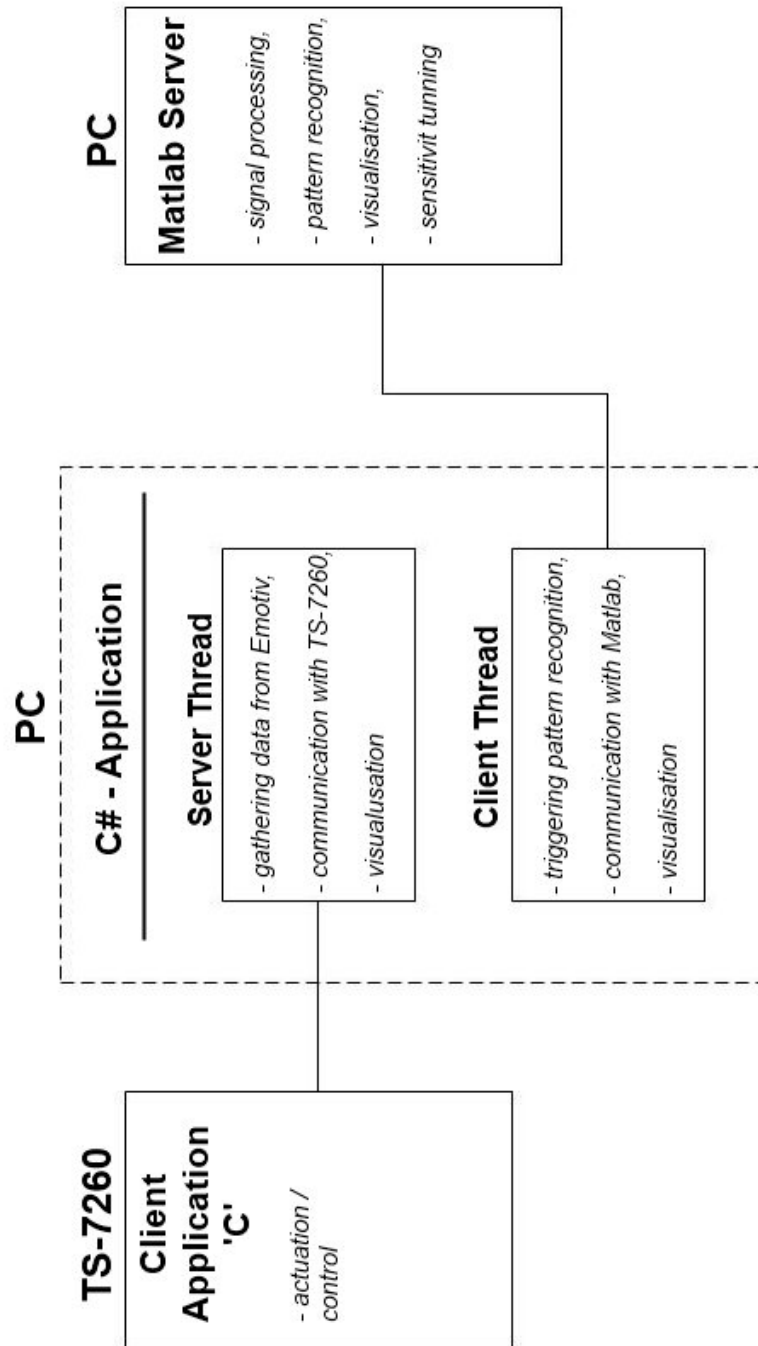
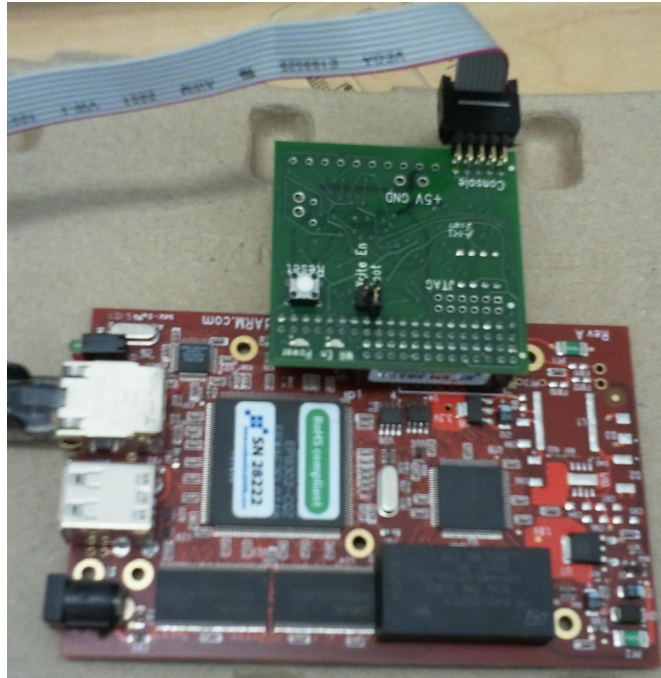


Figure 7.2: Block Scheme of Client-Server Application.

## 7.4 Implementation – Using Emotiv Headset

---



**Figure 7.3:** TS-7260 board.

the whole bio-signal processing, pattern recognition, filtration and the sensitivity tuning. It is possible to demonstrate the connection between PC and TS-7260 and between PC and MATLAB. In order to enable this, three applications (attached in Appendix C) had to be developed. The main application, written in C# – enabled connection with the TS-7260 board by pressing the 'Server' button and with MATLAB – by pressing the button 'Client'.

The second application was written in MATLAB only. It was also a server-type application in form of MATLAB script with JAVA functions that served sockets. This application also did the whole filtration and pattern recognition processes. After recognition of the pattern, it sent the information to the PC using C# application.

The last application, developed for this research purposes, was the embedded application. The embedded application was a client-type application on the TS-7260 board. It received message/information from the PC C#-application and according to the result – called appropriate procedures. In Figure 7.4 a screenshot illustrating the work of all implemented applications and the communication

## **7.4 Implementation – Using Emotiv Headset**

---

of all the elements was presented.

## 7.4 Implementation – Using Emotiv Headset

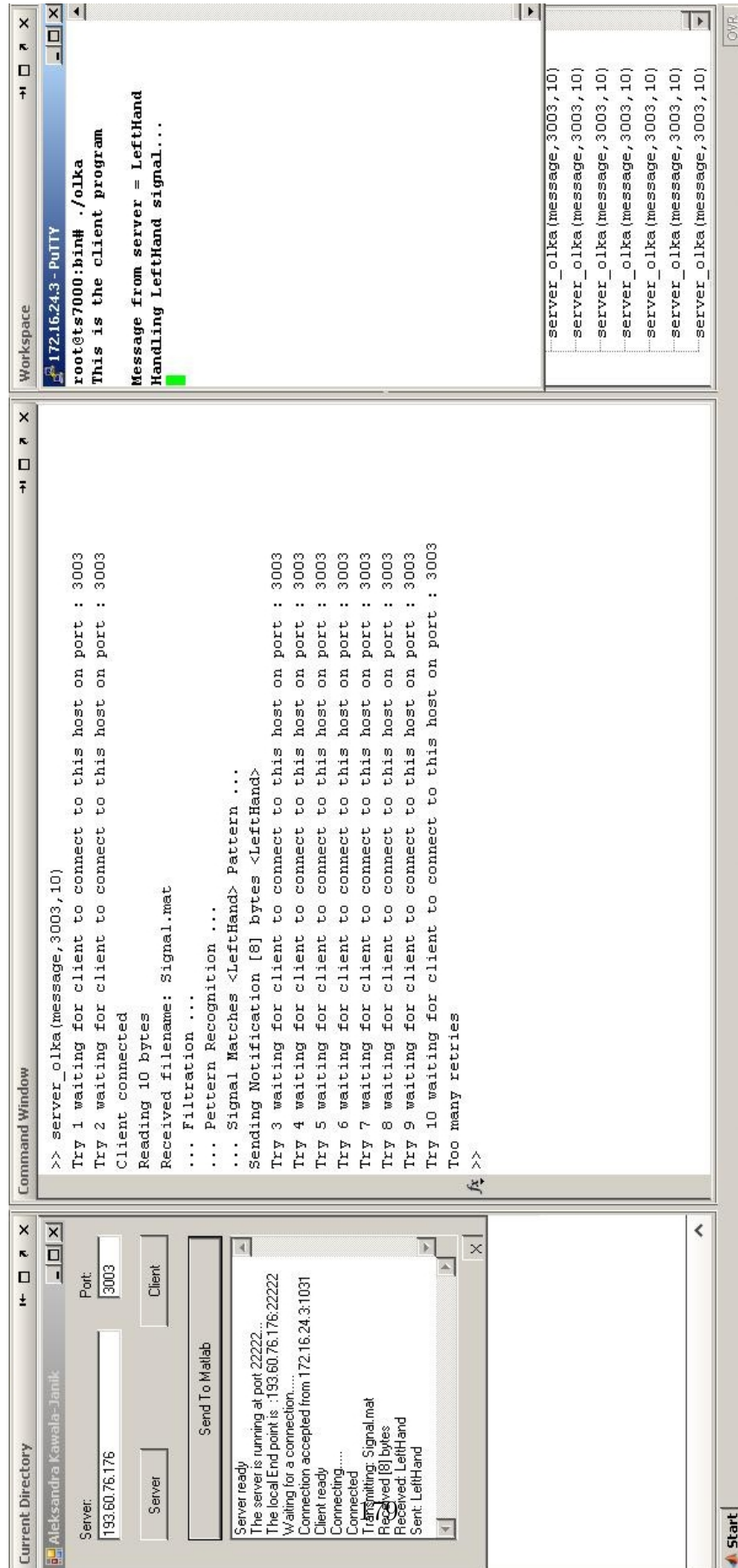


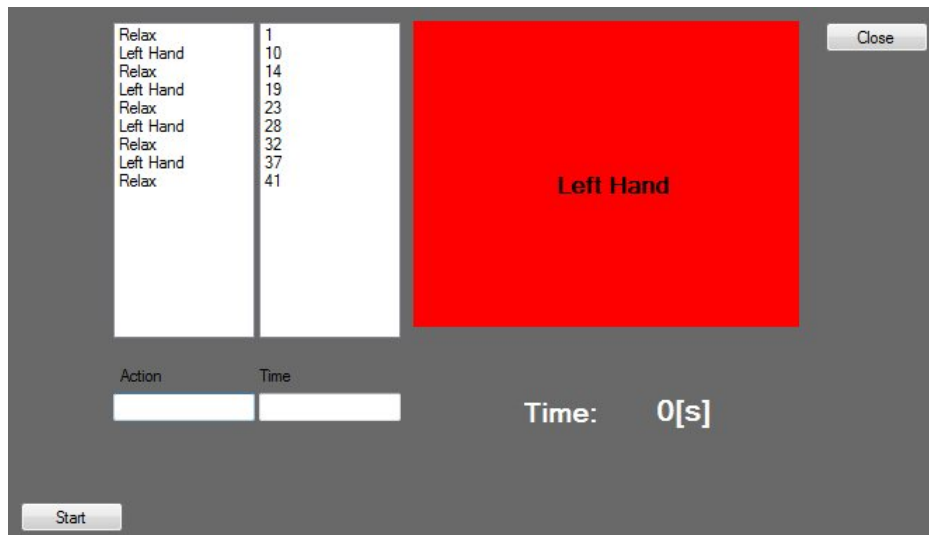
Figure 7.4: Screen-shot of working applications.

The code of application based on Equation 7.1 was relegated to Appendix C – (C.1).

## 7.5 Data Acquisition – Using Emotiv Headset

It is often planned for the experiments to use only one stimulus in the laboratory environment. This may be a kind of abstraction, as a 'simple' stimulus does not exist. Various stimuli may call various memories and brain reactions – an example is a wedding ring, which can both recall memories of wedding and sorrows of funeral, or divorce [12]. Therefore it was very hard to find a stimulus, which would bring the same or at least similar reaction of the brain.

For the research and experiments purposes – simple visual stimulating application was used. In Figures 7.5 – 7.7 screen shots of this stimulus application were presented. The participants of the research had to follow the instructions, which appeared on screen. Task 1 (Fig. 7.5) involved imaginary left hand movement, where Task 2 (Fig. 7.6) – imaginary right hand movement. Task 3 (Fig. 7.7) involved relaxing.

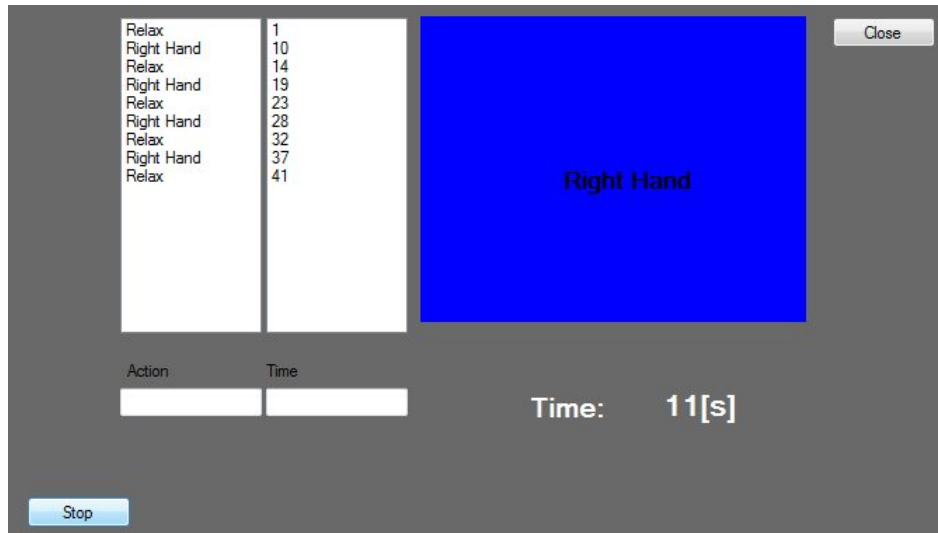


**Figure 7.5:** Task 1 – imaginary left hand movement.

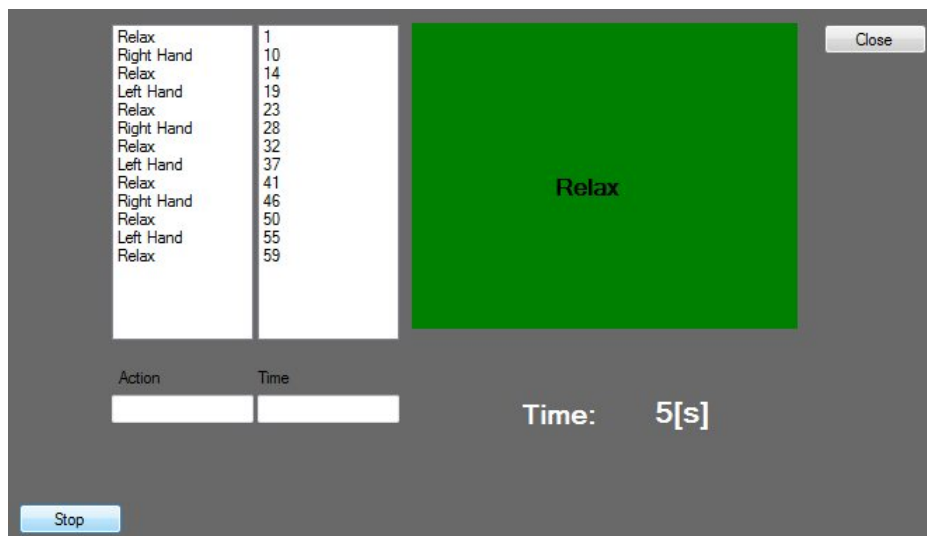
The subjects had to imagine appropriate hand movement, according to the message appearing on screen. In Figure 7.8 anonymous subject during the carried



## 7.5 Data Acquisition – Using Emotiv Headset



**Figure 7.6:** Task 2 – imaginary right hand movement.



**Figure 7.7:** Task 3 - relax.

## 7.6 Results Evaluation – Using Emotiv Headset

---

out experiment was presented.



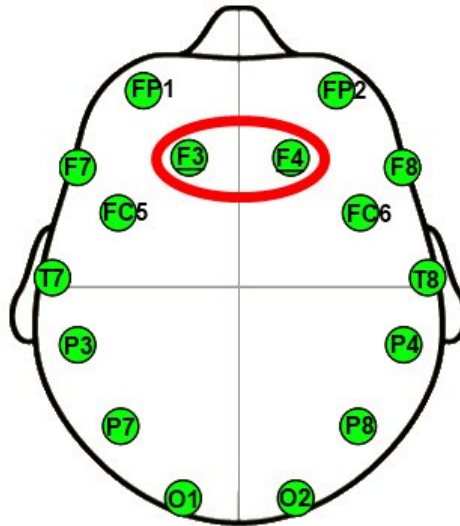
**Figure 7.8:** Subject with Emotiv EPOC headset during experiment.

The data was recorded from electrodes – F3 and F4, as presented in Figure 7.9. Imaginary right-hand movements were recorded from the F3-electrode, were F4-electrode provided signal occurring during imaginary left-hand movements.

## 7.6 Results Evaluation – Using Emotiv Headset

The steps that took place during running the signal-processing application is presented below. The first step required scaling the two compared signals in the time-domain. The next step presented single-amplitude spectra of the two signals. Then the signals were scaled in the frequency-domain. The summation criterion was applied and depending on results – the signals either matched or not. Presented below are the steps of signal processing application written in MATLAB.

```
<----- 01 ----->
<----- Scaling in time domain ----->
<----->
```



**Figure 7.9:** Electrodes used for the research purpose.

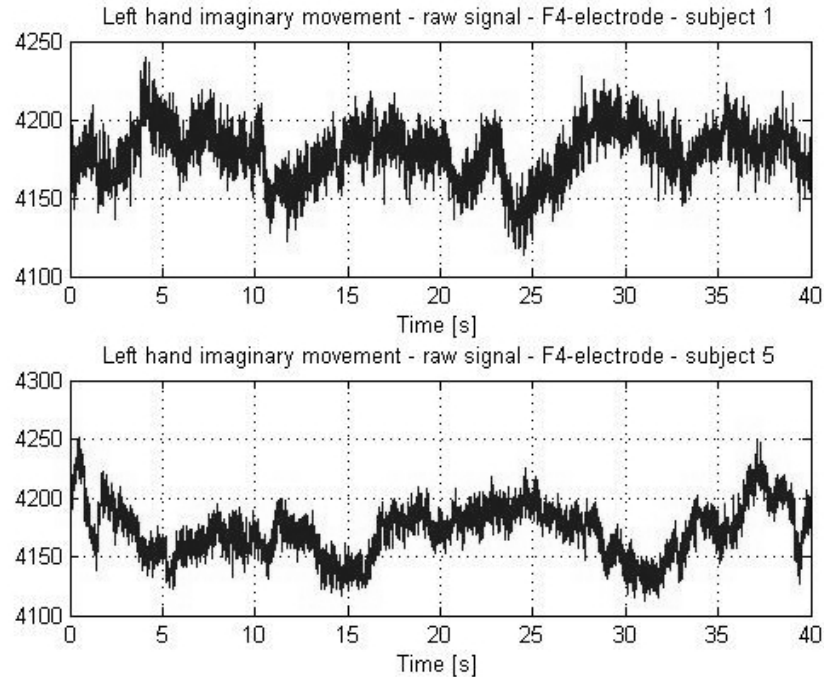
```

<----- 02 ----->
<----- Plot single-sided amplitude spectrum ----->
<----->
<----- 03 ----->
<----- Scaling in frequency domain ----->
<----->
<----- 04 ----->
<----- Applying summation criterion ----->
<----->
<----- 05 ----->
<----- Comparison result ----->
<----->
...the signals match...
res =
    1
    
```

In Figure 7.10 two different signals registered during imaginary left-hand movement have been presented. The signals were recorded from the 'F4'-electrode in a quiet, laboratory environment. Signals obtained from Subject 1 and Subject 5 were compared. This first example shows that the signals matched, despite be-

## 7.6 Results Evaluation – Using Emotiv Headset

ing recorded from different subjects, they were registered during the same task. No filtering was done, the compared signals were raw and unprocessed.



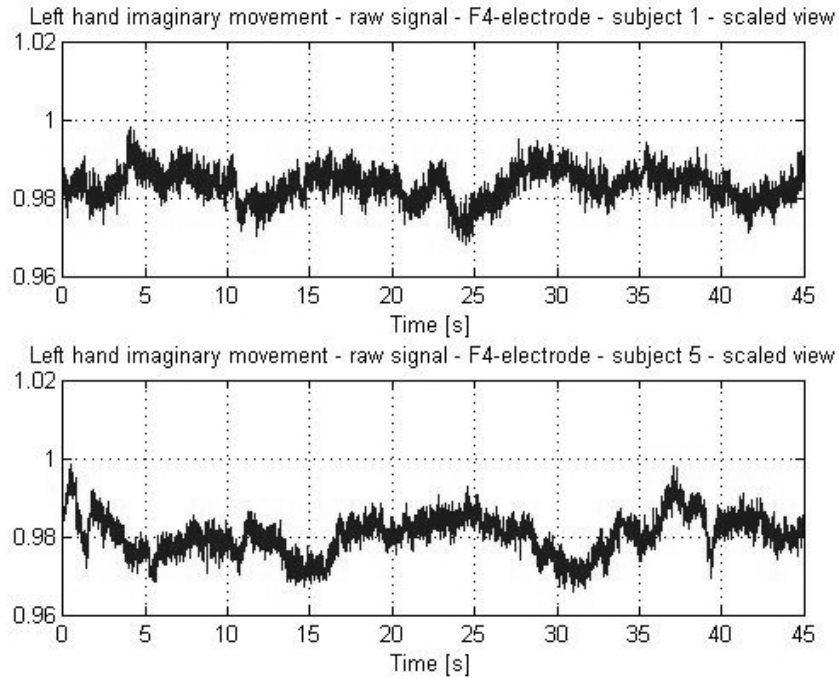
**Figure 7.10:** Imaginary left-hand movement – 'F4'-electrode – quiet environment – raw signals.

Figure 7.11 presents the same signals in a scaled view. This means, that the values were multiplied by ratio, so the values of the signals were presented in a normalised – [0-1] form.

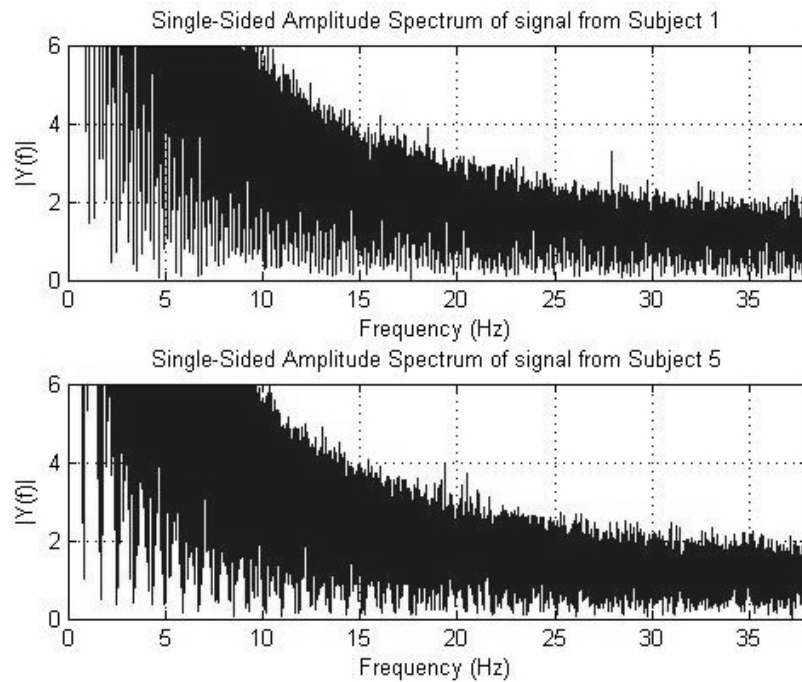
It is possible to notice 'peaks' present in signal, what may be considered as potential artifacts. However the proposed method contains features of mean-square method. This means that this method has attributes of averaging the values and as a result – the eventual 'peaks' occurring in signals will be eliminated.

Figure 7.12 illustrates fragments of single-sided amplitude spectra of the above mentioned signals. The signals were not identical, but still matched. Figure 7.13 presents the single-sided amplitude spectra in a scaled, based on frequency-domain view. The view was scaled for the desired frequency range – 8-12 [Hz]. Figures presenting single-sided amplitude spectra do not provide any relevant information regarding the chosen method.

## 7.6 Results Evaluation – Using Emotiv Headset

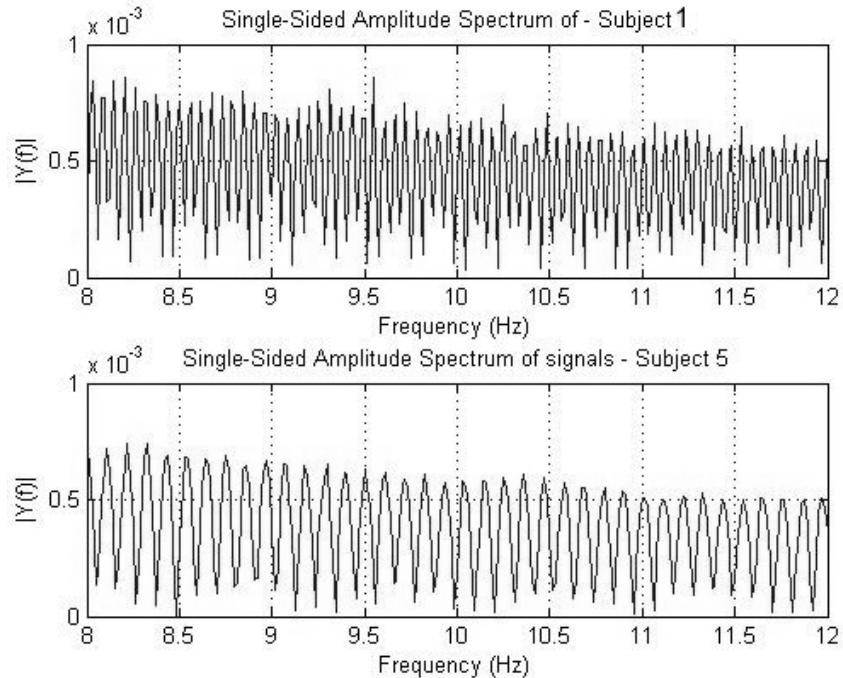


**Figure 7.11:** Imaginary left-hand movement – 'F4'-electrode – quiet environment – raw signals – scaled view.



**Figure 7.12:** Single-sided amplitude spectra of the signals.

## 7.6 Results Evaluation – Using Emotiv Headset

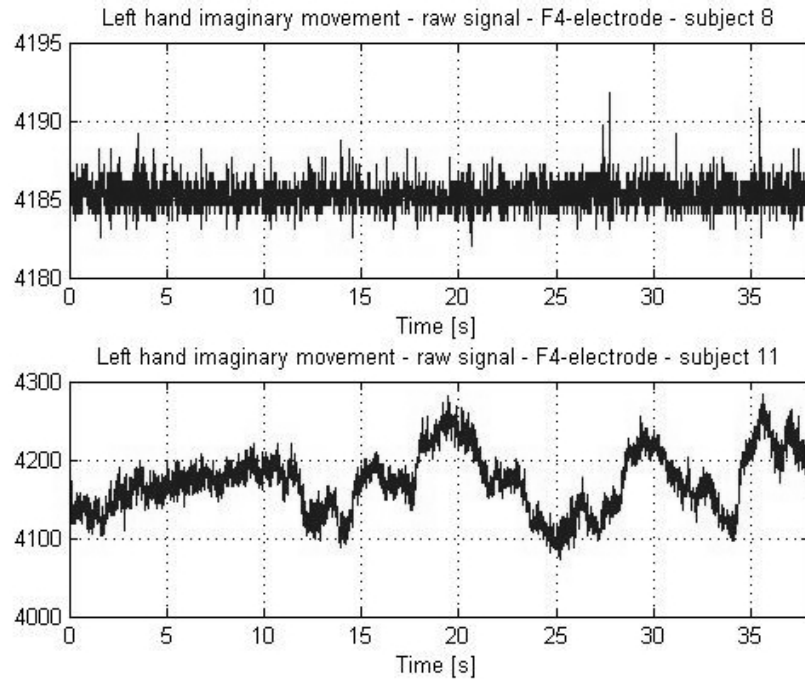


**Figure 7.13:** Single-sided amplitude spectra of the signals – scaled view.

Comparing signals recorded from Subject 8 and Subject 11 (Fig. 7.14 and Fig. 7.15), during left-hand movement in noisy environment showed that the signals do not match for the 'minimisation criterion'  $\leq 3$  (despite being registered during the same task). In this case – also no filtering was done, the compared signals were raw and unprocessed. In Figure 7.14 signals obtained from Subject 8 and Subject 11 in the time-domain are presented, where Fig. 7.15 presents these signals in a normalised, scaled view, which shows the difference between the signals. The  $\epsilon$  value was 0.34117.

Signals generated during imaginary right-hand movements were recorded from electrodes placed on F3 position. In Figure 7.16 two different signals have been compared. The signals were recorded from the 'F3'-electrode, also in quiet environment. Signals obtained from Subject 2 and Subject 6 were compared. No filtering was done, the compared signals were raw and unprocessed. The signals matched. Figure 7.17 illustrates scaled view of the two compared signals.

In the further part of this work, analysis of signals recorded in noisy environment was presented. The compared signals were raw (unfiltered). Figures



**Figure 7.14:** Imaginary left-hand movement – ‘F4’-electrode – noisy environment – raw signals.

7.18 and 7.19 presented signals gathered from Subject 3 and Subject 7. Signals were recorded in noisy environment during imaginary-right hand movement. The signals matched.

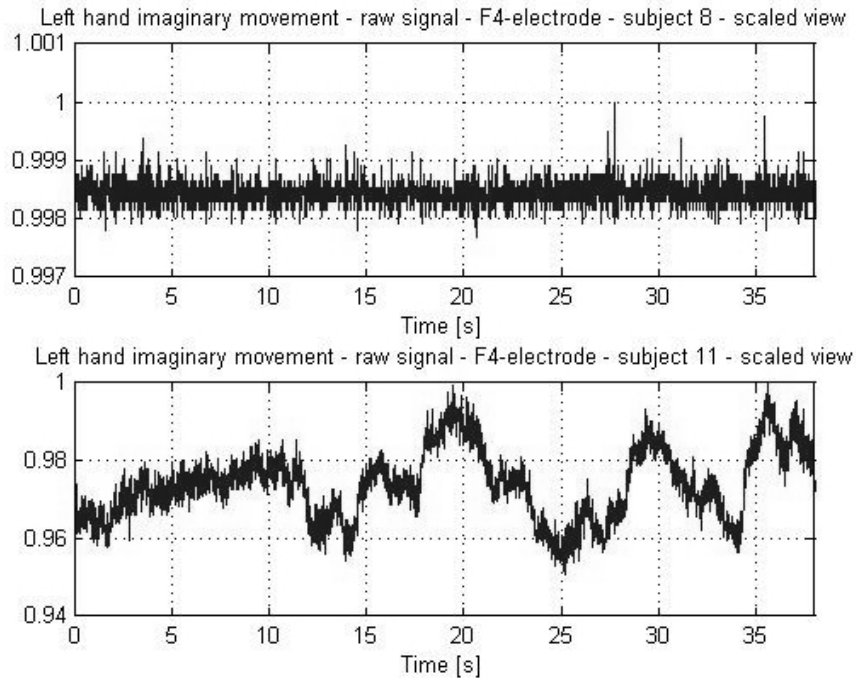
### 7.6.1 Filtering for the Research Purposes

In Figures 7.20 (Subject 1) and 7.21 (Subject 5) spectrograms of raw signals recorded from the electrode placed on F4 position on scalp, in quiet environment, were presented. The signals were caused by the imaginary left hand movements.

Figures 7.22 (Subject 8) and 7.23 (Subject 11) illustrate spectrograms of raw signals recorded from the electrode placed on F4 position on scalp. The signals were gained in this case in noisy environment, while subject imagined left-hand movements.

In Figures 7.24 (Subject 2) and 7.25 (Subject 6) spectrograms of raw signals recorded from the electrode placed on F3 position on scalp, in quiet environment, were presented. The signals were caused by the imaginary right hand movements.

## 7.6 Results Evaluation – Using Emotiv Headset



**Figure 7.15:** Imaginary left-hand movement – 'F4'-electrode – noisy environment – raw signals – scaled view.

Figures 7.26 (Subject 3) and 7.27 (Subject 7) illustrated spectrograms of raw signals recorded from the electrode placed on F3 position on scalp. The signals were gained in this case in noisy, similar to real-life conditions environment. The subject had to imagine right-hand movements.

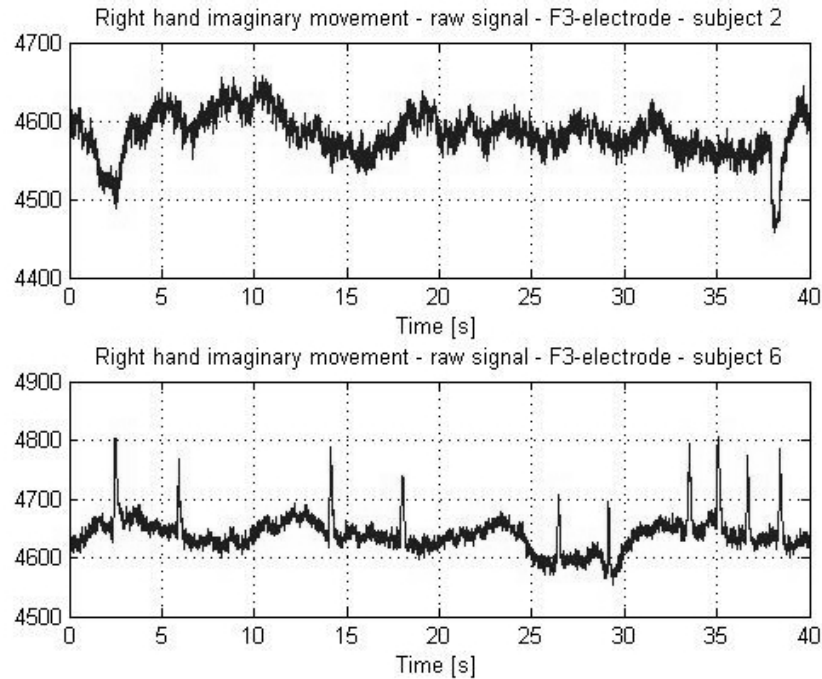
In Figure 7.28 Chebyshev Type I filter is shown. In Figure 7.29 – Chebyshev Type II filter was illustrated.

```
Fs = 128; % Sampling Frequency
N      = 12; % Order
Fpass1 = 8; % First Passband Frequency
Fpass2 = 12; % Second Passband Frequency
Apass  = 1; % Passband Ripple (dB)
h = fdesign.bandpass('N,Fp1,Fp2,Ap', N, Fpass1, Fpass2, Apass, Fs);
Hd = design(h, 'cheby1');
```

```
Fs = 128; % Sampling Frequency
```



## 7.6 Results Evaluation – Using Emotiv Headset



**Figure 7.16:** Imaginary right-hand movement – 'F3'-electrode – quiet environment – raw signals.

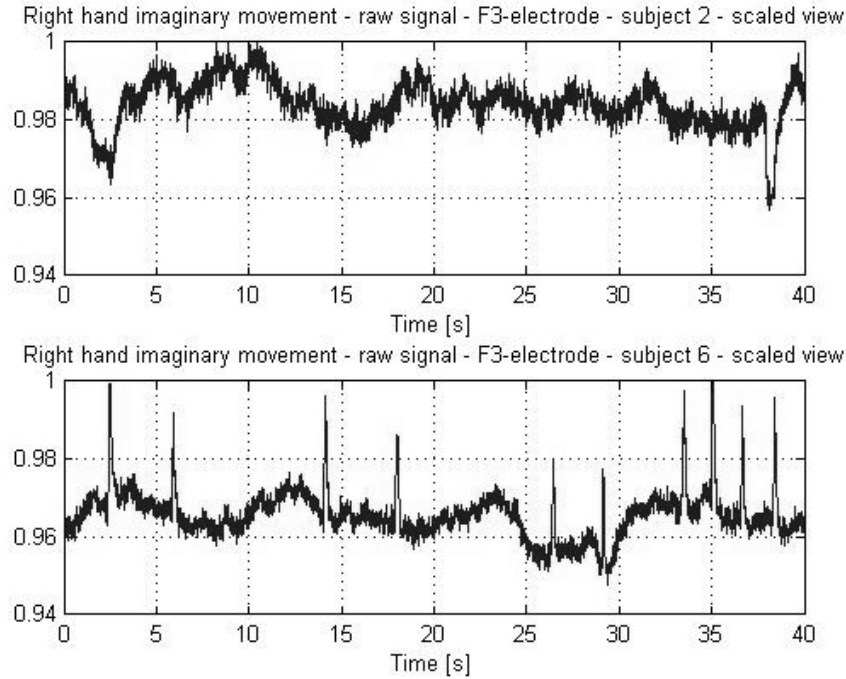
```
N      = 12; % Order
Fstop1 = 8; % First Stopband Frequency
Fstop2 = 12; % Second Stopband Frequency
Astop  = 80; % Stopband Attenuation (dB)
h      = fdesign.bandpass('N,Fst1,Fst2,Ast', N, Fstop1, Fstop2, Astop, Fs);
Hd     = design(h, 'cheby2');
```

Both types – I and II of the Chebyshev filters trade off flatness in the pass band for a steeper decline into the stop band. Designed filters have a recurring wavelike ripple of attenuation in the passband of usually 0.05db to 3db.

The advantage is that a much steeper portion of the attenuation curve near the cut-off frequency may be obtained, however waveforms are distorted by group delay errors more severely than in case the Butterworth filter is applied. The higher the ripple the worse the distortion.

In analysis of signals as sensitive and complex as EEG Butterworth filters are at most popular and therefore (after some initial tests) have been applied for this

## 7.6 Results Evaluation – Using Emotiv Headset



**Figure 7.17:** Imaginary right-hand movement – 'F3'-electrode – quiet environment – raw signals – scaled view.

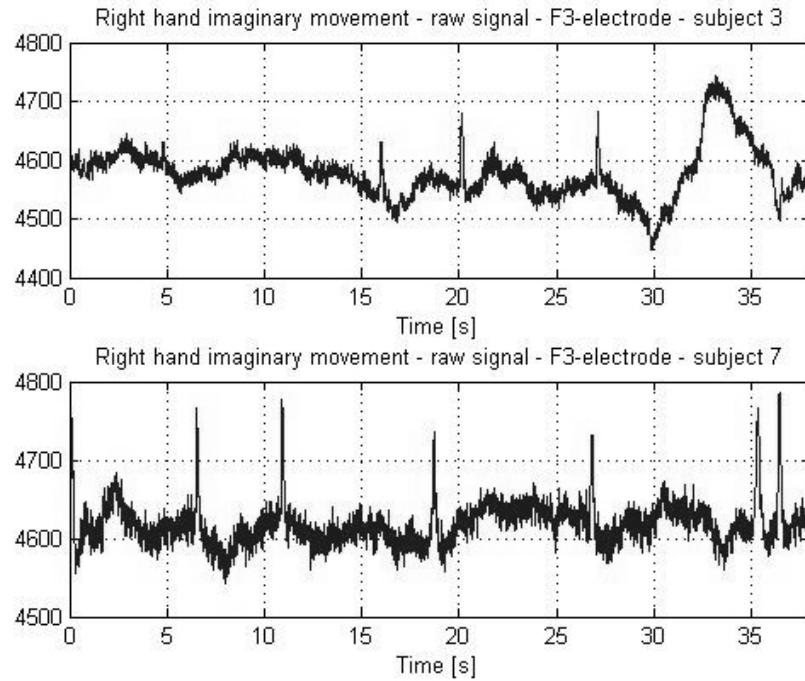
study purposes.

The Butterworth Filter is the maximally flat amplitude filter. It provides a near 0 attenuation until near the cut-off frequency and then descends into attenuation smoothly. The transition becomes sharper with higher orders. It has moderate group delay so it has some overshoot on sharp rising waveforms, however it may this gets worse with the application of higher order filters.

Figures 7.30 – 7.37 illustrate spectrograms of signals filtered with the designed Butterworth filter. Figures 7.30 (Subject 1) and 7.31 (Subject 5) present spectrograms of the filtered signals recorded from the electrode placed on F4 position. The signals were gained in this case in quiet environment. The subject had to imagine left-hand movements.

In Figures 7.32 (Subject 8) and 7.33 (Subject 11) spectrograms of the filtered signals recorded from the electrode placed on F4 position were presented. The signals were gained in this case in noisy, similar to real-life conditions environment. The subject had also to imagine left-hand movements.

## 7.6 Results Evaluation – Using Emotiv Headset

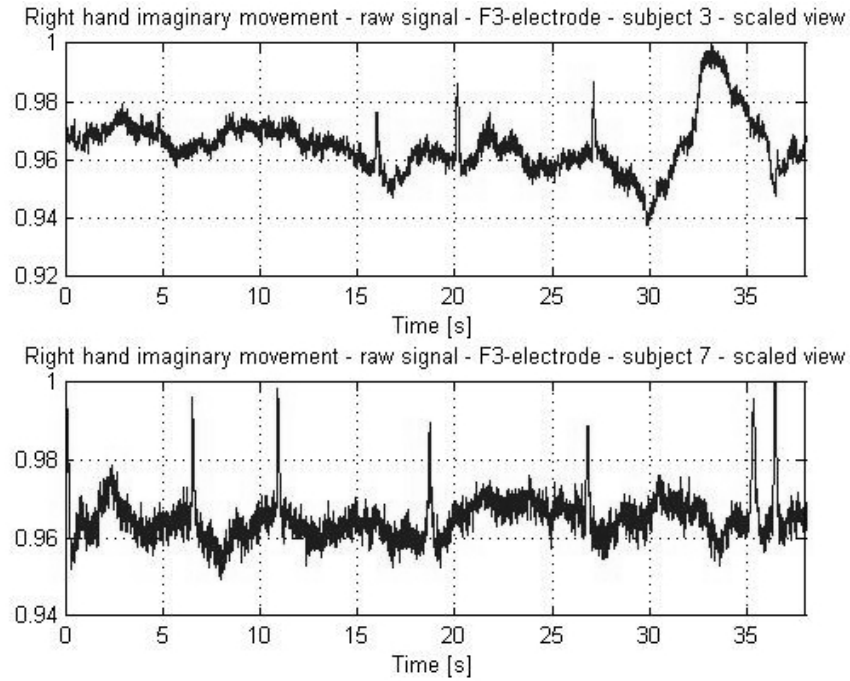


**Figure 7.18:** Imaginary right-hand movement – 'F3'-electrode – noisy environment – raw signals.

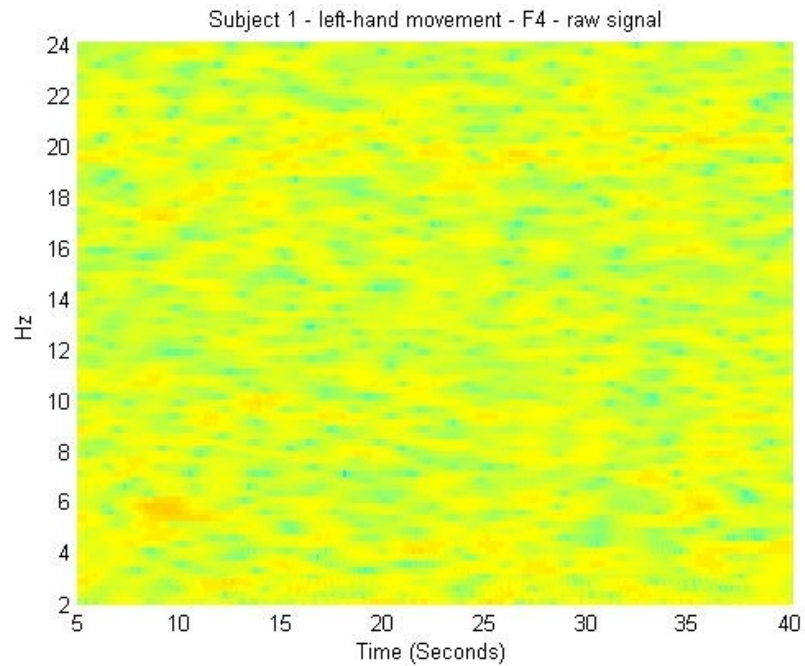
In Figures 7.34 (Subject 2) and 7.35 (Subject 6) spectrograms of the filtered signals recorded from the electrode placed on F3 during right-hand movements were presented. The signals were registered in quiet, isolated environment. The subject had to imagine right-hand movements.

In Figures 7.36 (Subject 3) and 7.37 (Subject 7) were illustrated spectrograms of the filtered signals recorded from the electrode placed on F3 position. The signals were recorded in this case in noisy, similar to real-life conditions environment, while the subject imagined right hand movements.

## 7.6 Results Evaluation – Using Emotiv Headset



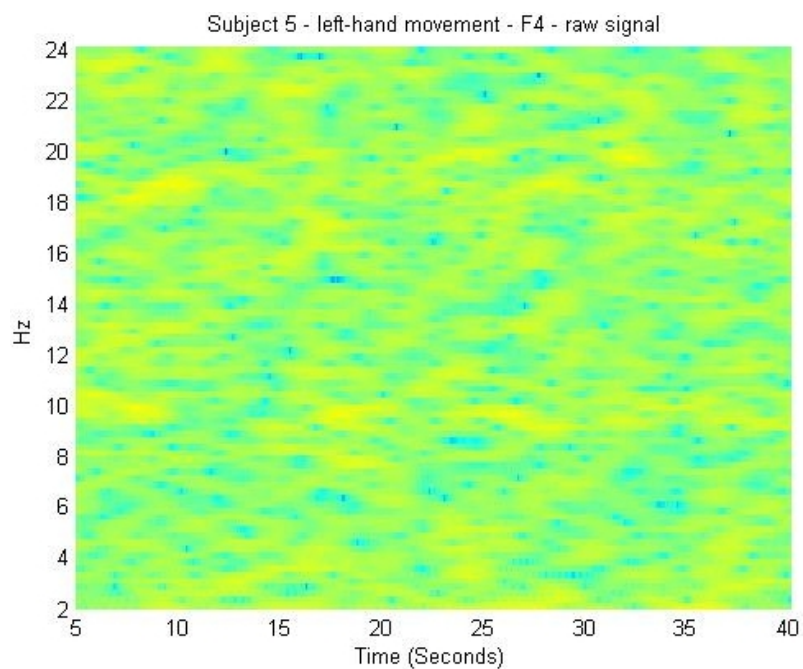
**Figure 7.19:** Imaginary right-hand movement – 'F3'-electrode – noisy environment – raw signals – scaled view.



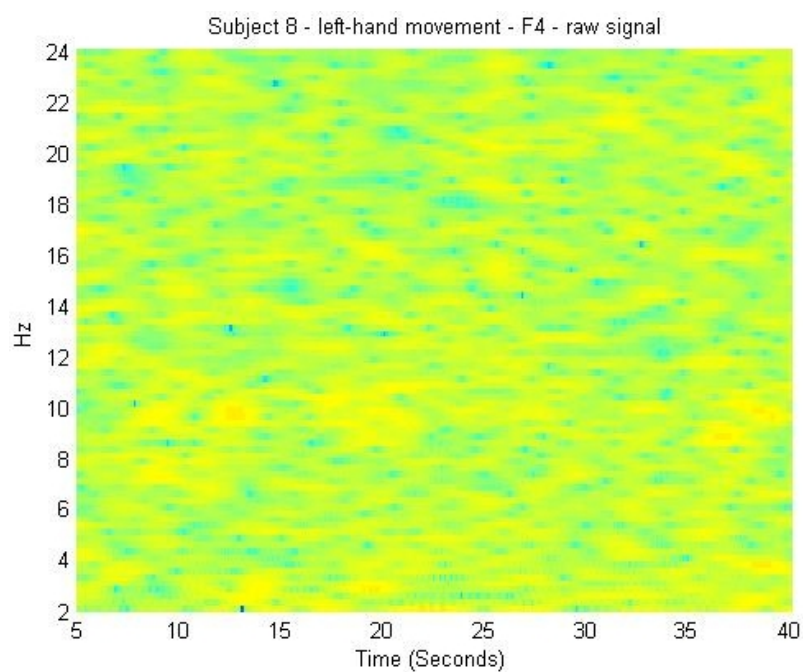
**Figure 7.20:** Spectrogram of a raw signal – left-hand movement – Subject 1 – F4 – quiet environment.

## 7.6 Results Evaluation – Using Emotiv Headset

---



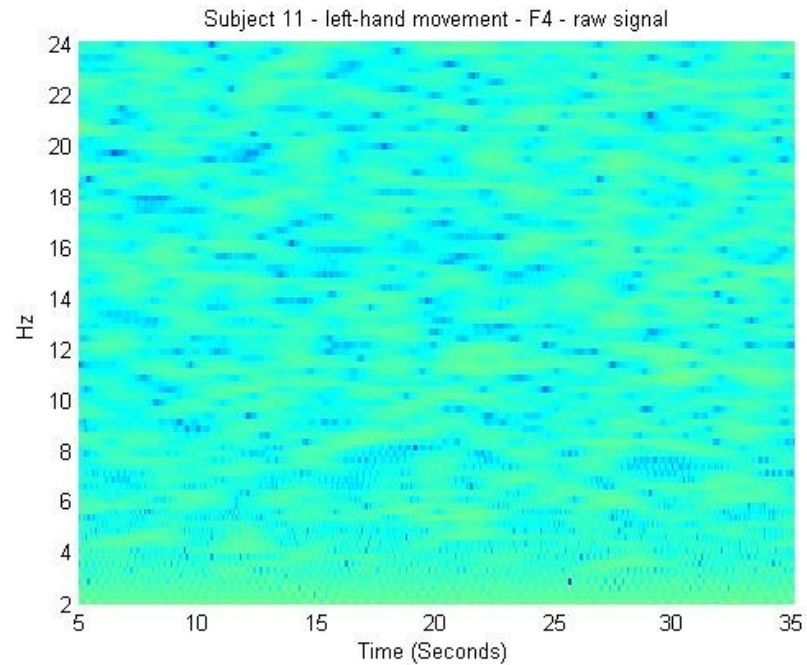
**Figure 7.21:** Spectrogram of a raw signal – left-hand movement – Subject 5 – F4 – quiet environment.



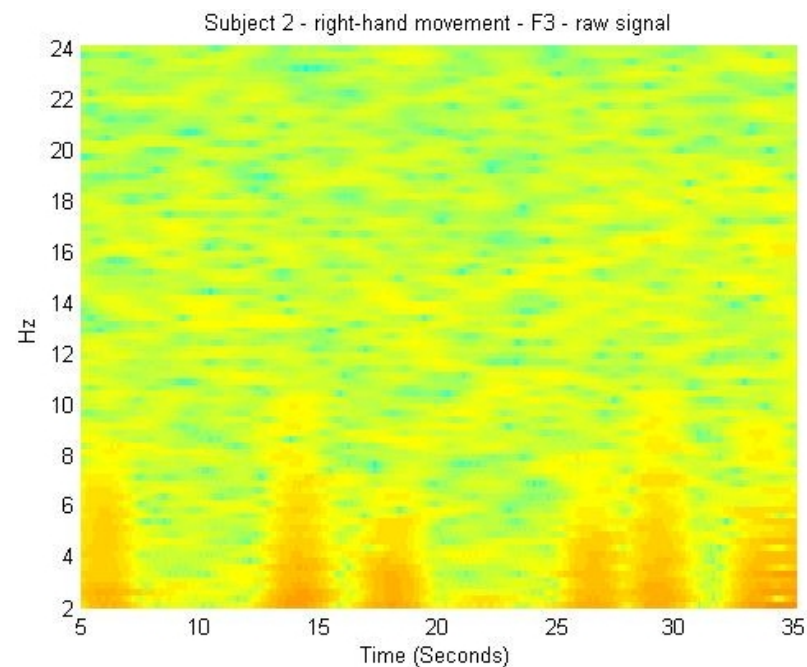
**Figure 7.22:** Spectrogram of a raw signal – left-hand movement – Subject 8 – F4 – noisy environment.

## 7.6 Results Evaluation – Using Emotiv Headset

---



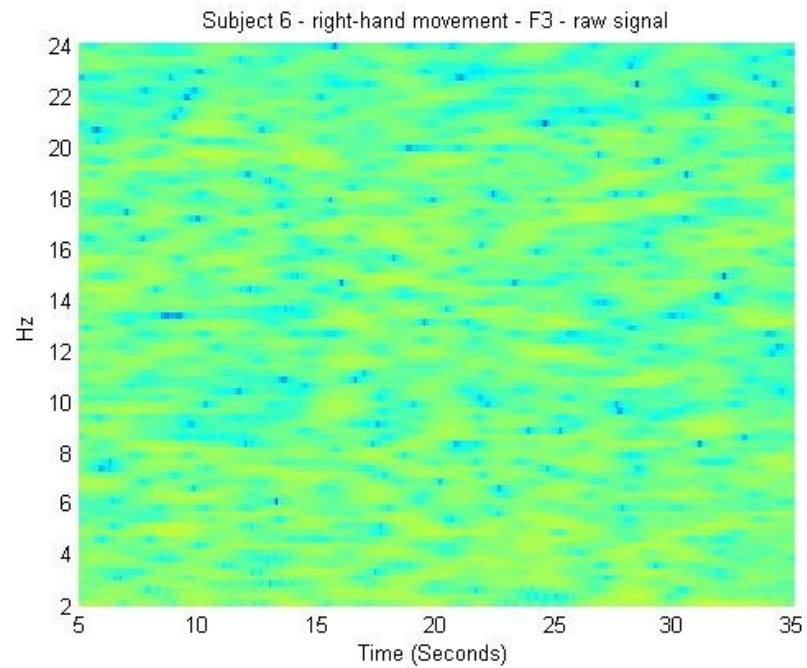
**Figure 7.23:** Spectrogram of a raw signal – left-hand movement – Subject 11 – F4 – noisy environment.



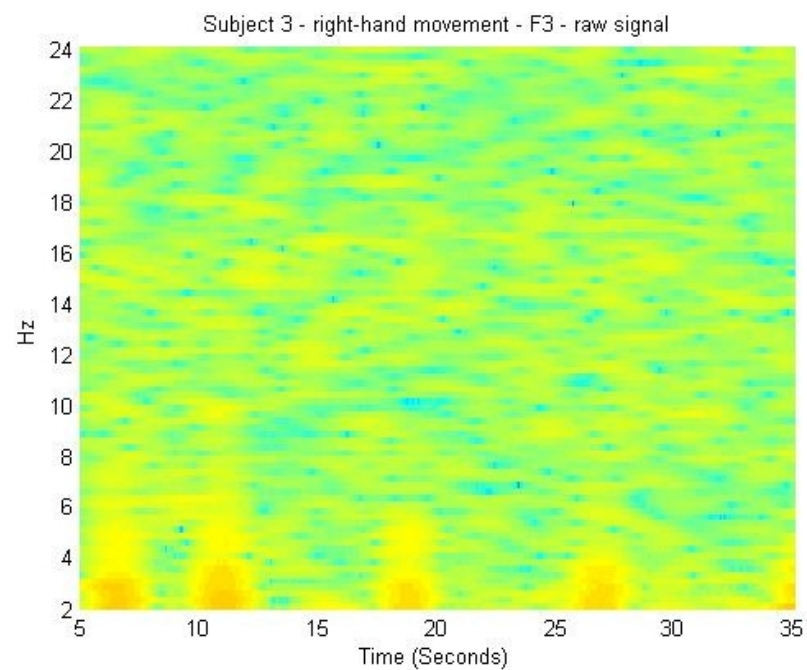
**Figure 7.24:** Spectrogram of a raw signal – right-hand movement – Subject 2 – F3 – quiet environment.

## 7.6 Results Evaluation – Using Emotiv Headset

---

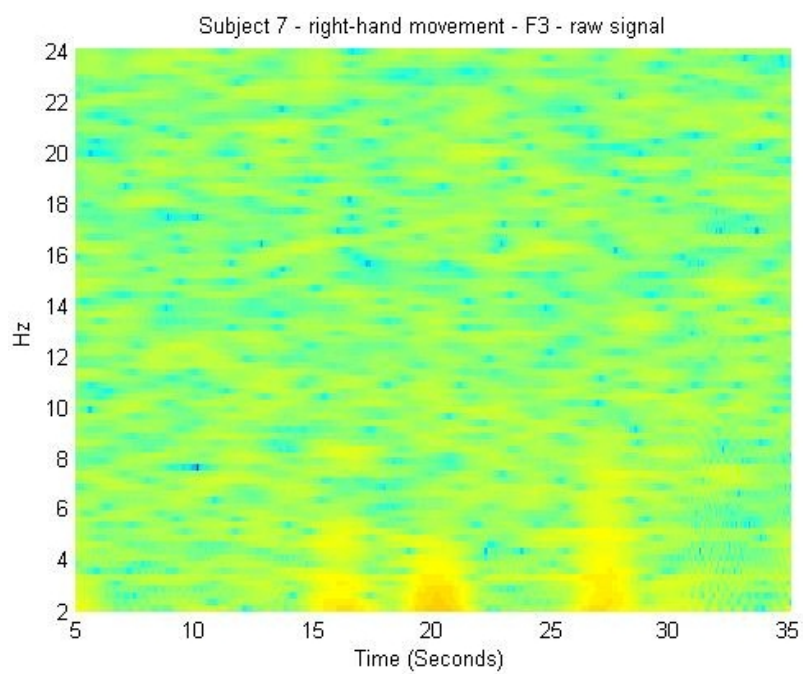


**Figure 7.25:** Spectrogram of a raw signal – right-hand movement – Subject 6 – F3 – quiet environment.

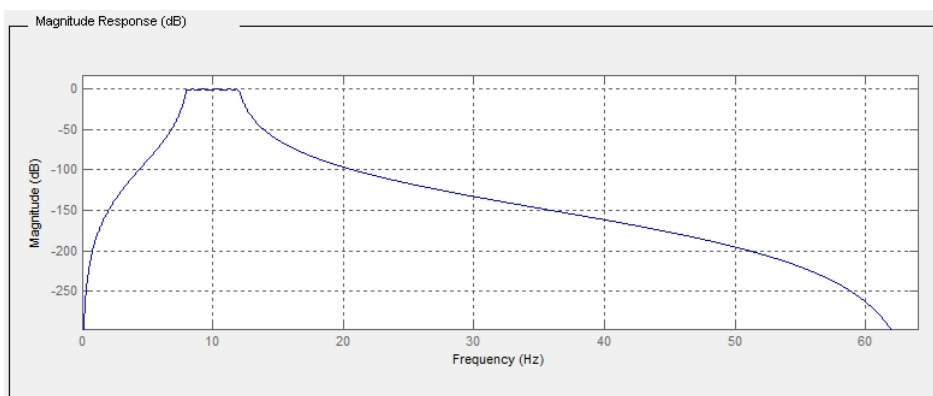


**Figure 7.26:** Spectrogram of a raw signal – right-hand movement – Subject 3 – F3 – noisy environment.

## 7.6 Results Evaluation – Using Emotiv Headset



**Figure 7.27:** Spectrogram of a raw signal – right-hand movement – Subject 7 – F3 – noisy environment.



**Figure 7.28:** Chebyshev Type I – designed filter.



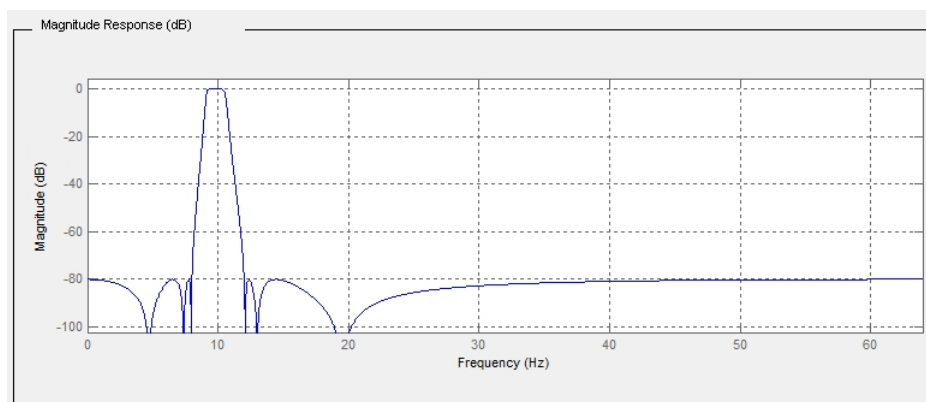


Figure 7.29: Chebyshev Type II – designed filter.

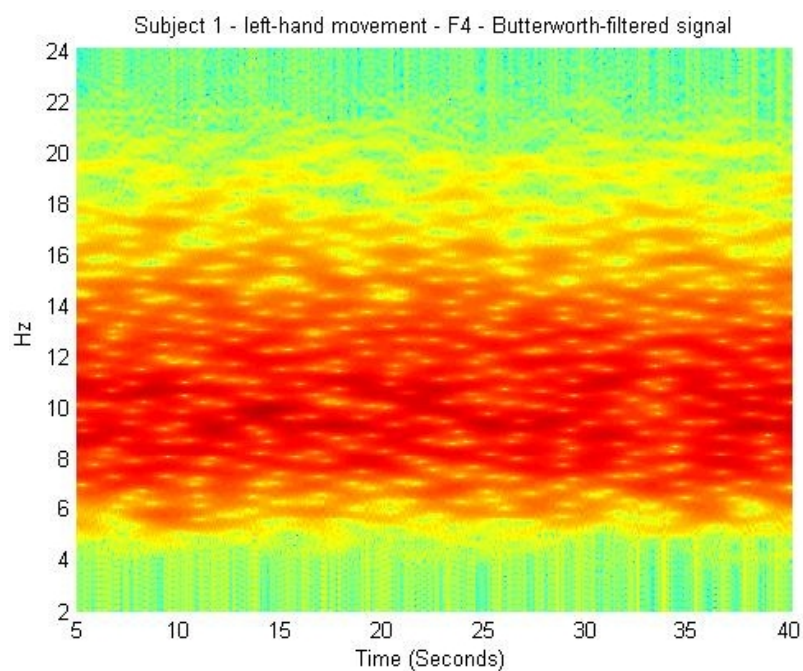
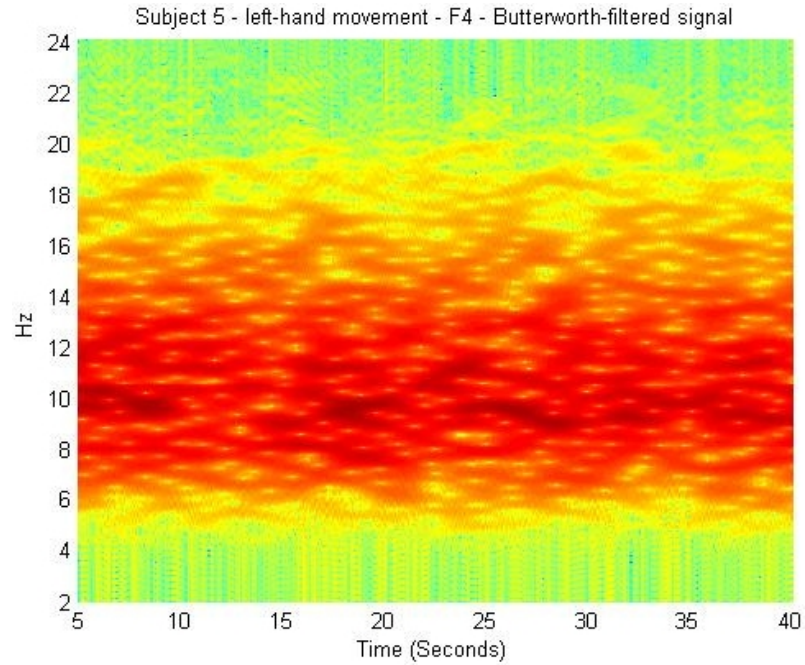
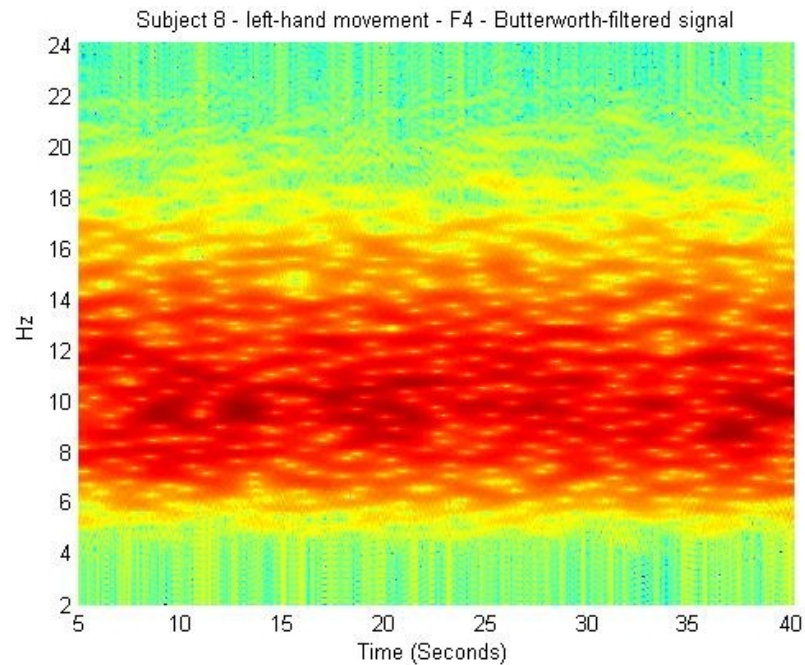


Figure 7.30: Spectrogram of a Butterworth-filtered signal – left-hand movement – Subject 1 – F4 – quiet environment.

## 7.6 Results Evaluation – Using Emotiv Headset

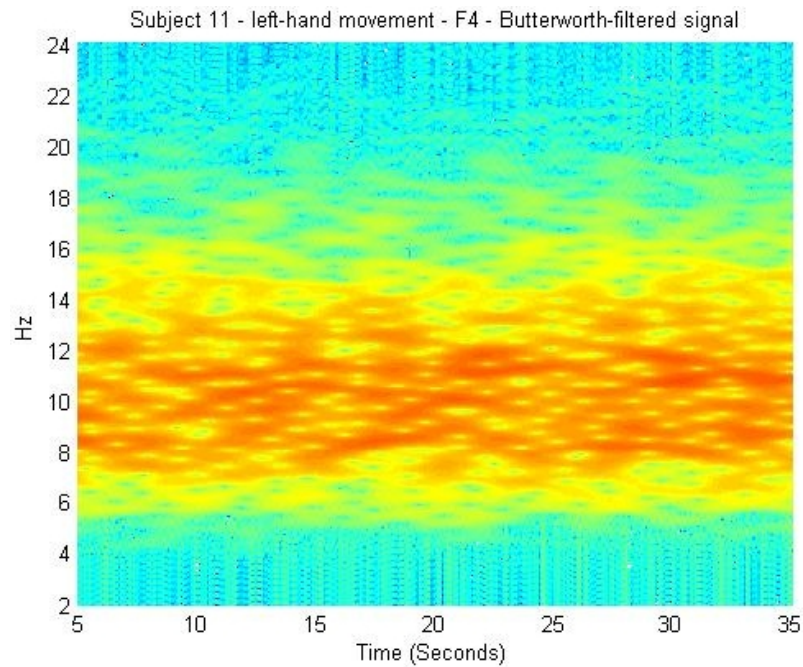


**Figure 7.31:** Spectrogram of a Butterworth-filtered signal – left-hand movement – Subject 5 – F4 – quiet environment.

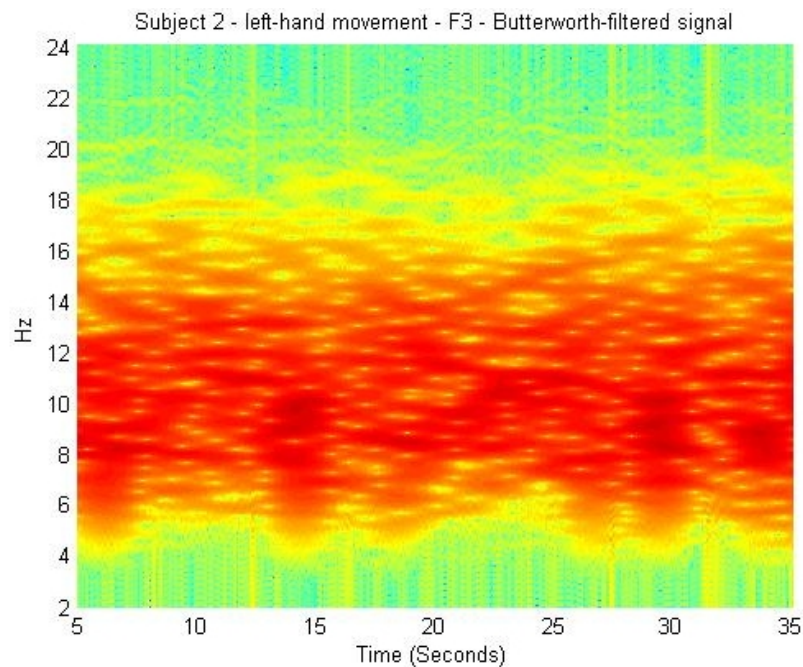


**Figure 7.32:** Spectrogram of a Butterworth-filtered signal – left-hand movement – Subject 8 – F4 – noisy environment.

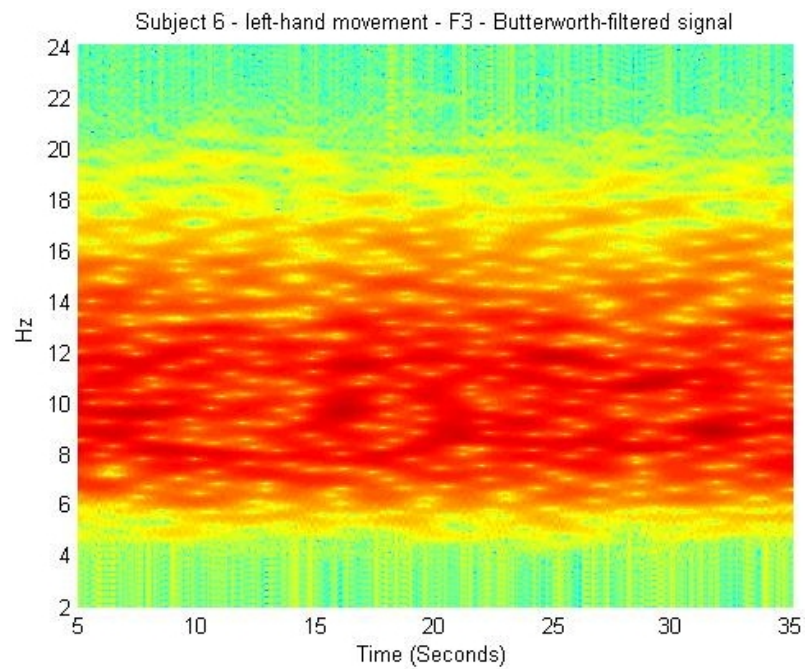
## 7.6 Results Evaluation – Using Emotiv Headset



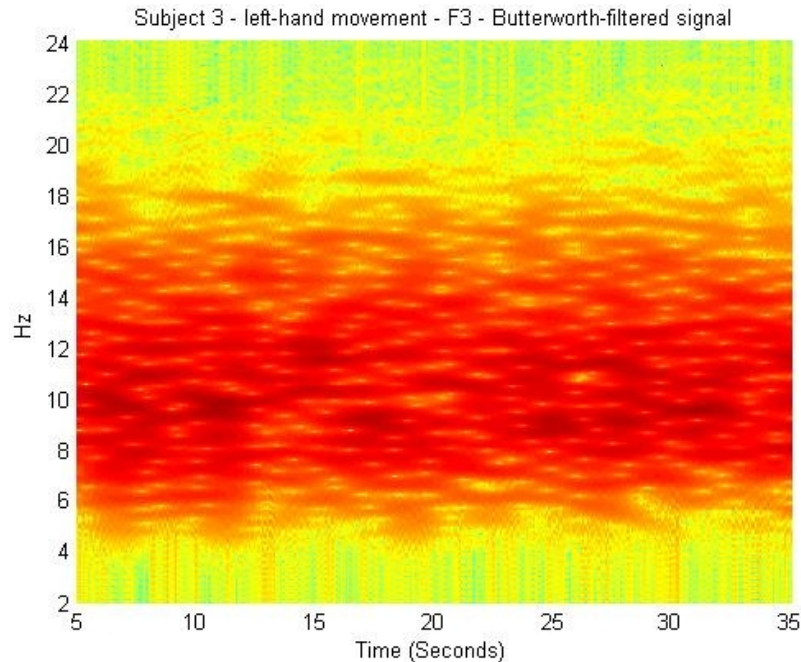
**Figure 7.33:** Spectrogram of a Butterworth-filtered signal – left-hand movement – Subject 11 – F4 – noisy environment.



**Figure 7.34:** Spectrogram of a Butterworth-filtered signal – right-hand movement – Subject 2 – F3 – quiet environment.



**Figure 7.35:** Spectrogram of a Butterworth-filtered signal – right-hand movement – Subject 6 – F3 – quiet environment.



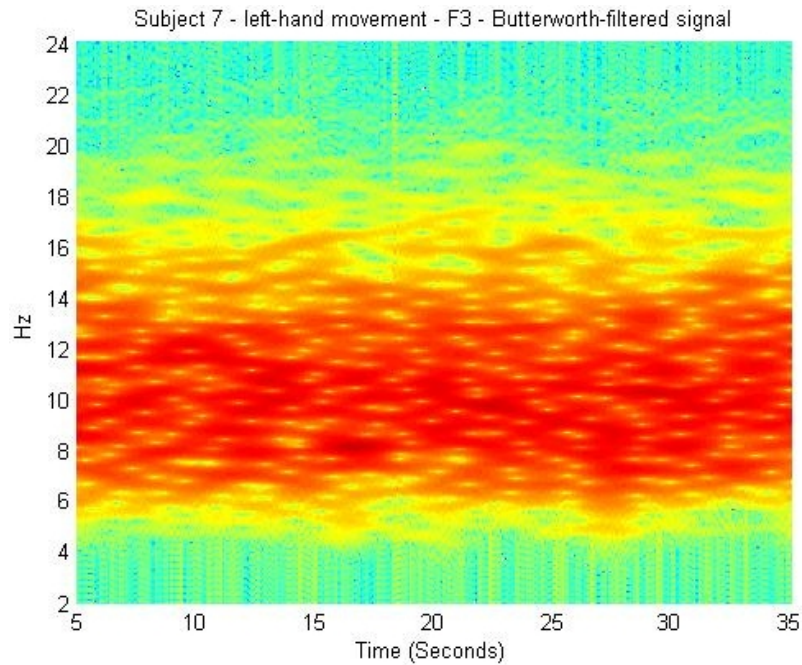
**Figure 7.36:** Spectrogram of a Butterworth-filtered signal – right-hand movement – Subject 3 – F3 – noisy environment.

Filtered signals have also been compared using the invented method. In Figure 7.38 signals from Subject 1 and Subject 2 were analysed. The signals were filtered with the implementation of Butterworth filter. The analysis showed that the signals did not match for the 'minimisation criterion'  $\leq 1$  (despite being registered during the same task). The signals were recorded in quiet environment, from the F4 electrode, during left-hand movement. The  $\epsilon$  value was 0.11889. The application of filtration proved that the signals did not match, although the same signals compared without any signal processing (filtration) matched.

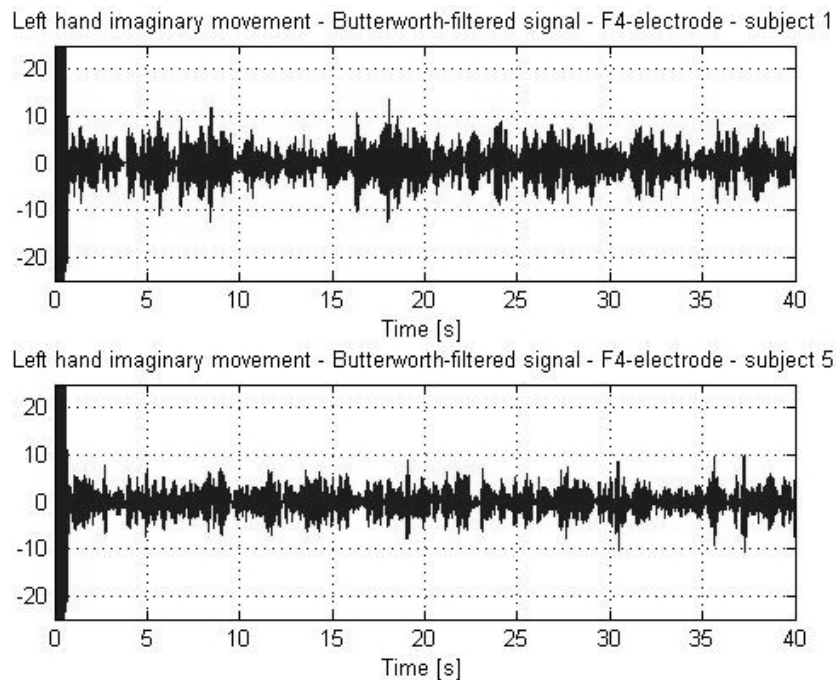
In Figure 7.39 signals from Subject 8 and Subject 11 were analysed. The signals were also filtered with the implementation of Butterworth filter. The analysis showed that the signals matched, although they seemed to look very different. The signals were recorded in noisy environment, from the F4 electrode, during left-hand movement. In this case – filtering has improved the result, as the same raw signals did not match.

In Figure 7.40 signals from Subject 2 and Subject 6 were compared. The signals were filtered with the Butterworth filter. The analysis showed that the

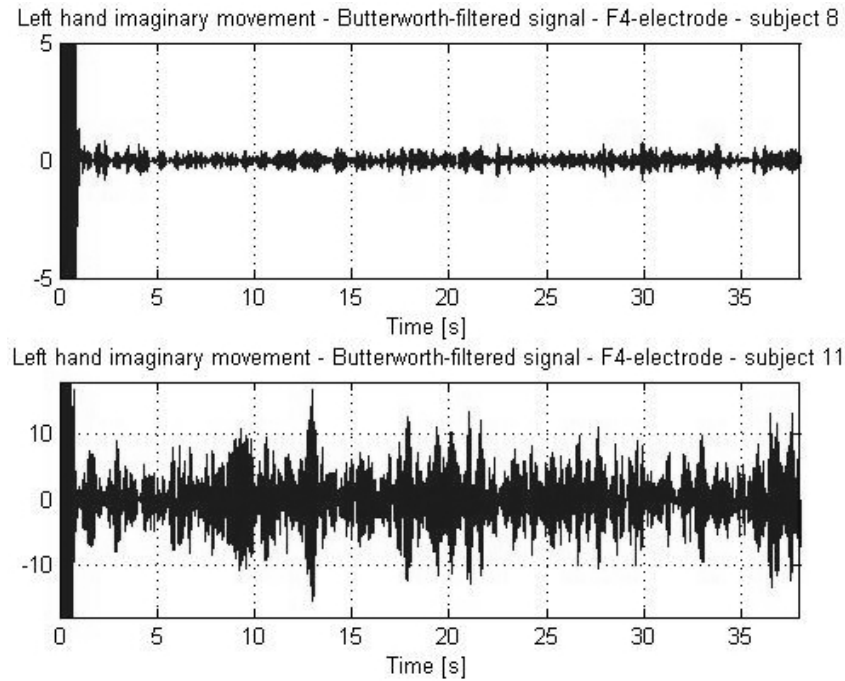
## 7.6 Results Evaluation – Using Emotiv Headset



**Figure 7.37:** Spectrogram of a Butterworth-filtered signal – right-hand movement – Subject 7 – F3 – noisy environment.



**Figure 7.38:** Imaginary left-hand movement – 'F4'-electrode – quiet environment – Butterworth-filtered signals.



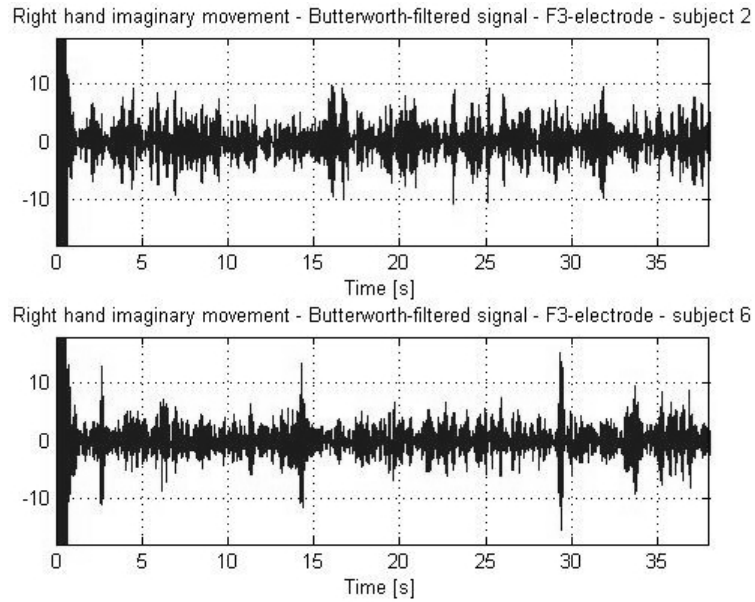
**Figure 7.39:** Imaginary left-hand movement – ‘F4’-electrode – noisy environment – Butterworth-filtered signals.

signals matched. The signals were recorded in quiet environment, from the F3 electrode, during imaginary right-hand movement.

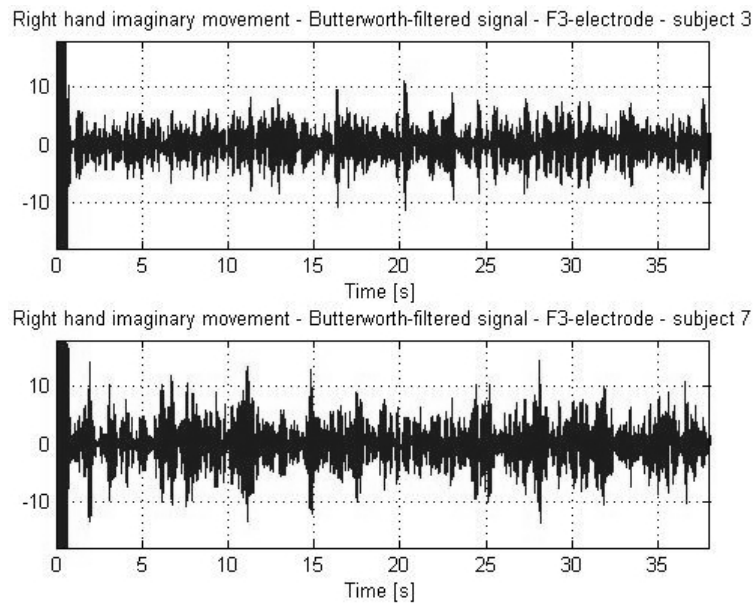
In Figure 7.41 signals from Subject 3 and Subject 7 were matched. The signals were filtered with the implementation of Butterworth filter. The analysis showed that the signals did not match for the ‘minimisation criterion’  $\leq 1$  (despite being registered during the same task). The signals were recorded in quiet environment, from the F4 electrode, during left-hand movement. The  $\epsilon$  value was 0.11426. The application of filtration proved that the signals did not match, although the same signals compared without any signal processing (filtration) matched.

## 7.7 Discussion – Using Emotiv Headset

All the numeric procedures in this stage were conducted in MATLAB. This stage of research presented communication between PC and TS-7260 board and between PC and MATLAB, what resulted in building a system, which may be-



**Figure 7.40:** Imaginary right-hand movement – 'F3'-electrode – quiet environment – Butterworth-filtered signals.



**Figure 7.41:** Imaginary right-hand movement – 'F3'-electrode – noisy environment – Butterworth-filtered signals.



## 7.7 Discussion – Using Emotiv Headset

---

come in the future fully working – BCI. The analysed signals EEG signals did not contain the full information and the applied filtering did not improve the results significantly. It was very surprising that for analysis of two different signals – the better results were achieved in noisy environment. Adopted tools for signal processing could be more sophisticated, although it might led to prohibitive computational burdens, in particular in the embedded system environment selected owing to the low-cost implementation prerequisite. Also the implementation of Emotiv EPOC headset had some disadvantages, as the device was not used for clinical applications and therefore the accuracy of the registered signal was not very high.

All results of the conducted experiments were presented in the form of tables and moved to the Appendix – (D).

# 8

## Conclusions and Further Work

In this chapter contributions of the carried out research together with plans for the further, post-doc work, were presented in more detail. Contribution of the research consist of discussion regarding prospective implementation of the developed method and potential construction of working customised equipment.

### 8.1 Contribution of Research

This project has raised some challenges and interesting questions about efficient using inexpensive EEG amplifiers such as Emotiv EPOC headset. The implementation of basic mathematical operations for the signal processing purposes presented a novel approach in the BCI studies area, where very complex, sophisticated signal processing methods are usually applied. The study consisted of three stages. The very first stage – preliminary study – relied on building a customised EEG equipment. The device consisted of two channels placed on C3 and C4 positions. The results resulting from the study conducted with the implementation of the customised equipment have led to the latter use of professional, clinical equipment.

It was also (wrongly) estimated that the information in time-progress of signals gained from the electrodes C3 and C4 were able to contain the information about pictures (visual stimulus) observed by the subject, what might have been used for the BCI design purposes. The implementation of the Morlet Wavelets proved that this method was not suitable for Brain-Computer Interfaces due to

the latency appearance. In BCI systems very fast response is absolutely required. The first stage, although not successfully completed, provided numerous crucial information regarding construction of customised equipment, electronic and bio-signals. The knowledge may be used for further research purposes. It also proved that traditional statistical methods were not suitable for the implementation of the embedded systems.

It has proven later that the channel location should be different. Tests conducted on the customised device proved that the quality of the final design was not satisfactory and thus the accuracy was very low. The gained signals were of very poor quality, which made the further analysis impossible.

The device used in the pilot study was inappropriate due to its very low accuracy, which resulted in poor quality signals. Using professional, medical equipment supposed to enable recording of good quality EEG signals. Unfortunately – despite using band-pass filtering – the obtained signals were over-hyped and very noisy. The reason for this was that medical equipment is very sensitive and was able to register external artifacts. It was usually used in quiet, muffled rooms, which made it impossible to apply in similar to real-life conditions. The device was also not portable, which also made it impossible for the Brain-Computer Interface implementation. Carried out research not only provided more information about EEG data analysis, but also proved that sound stimuli implementation is unsuitable for research purposes. It also proved that double filtering used in off-line analysis could be an efficient solution due to decreased latency.

The final stage of the study provided some satisfactory results. All the numeric procedures were conducted in MATLAB. This stage of research presented communication between PC and TS-7260 board and between PC and MATLAB, what resulted in building a system, which may become in the future fully working – BCI. The analysed signals EEG signals did not contain the full information and the applied filtering did not improve the results significantly. It was very surprising that for analysis of two different signals – the better results were achieved in a noisy environment. Adopted tools for signal processing could be more sophisticated, although it might lead to prohibitive computational burdens, in particular in the embedded system environment selected owing to the low-cost implementation prerequisite. Also the implementation of Emotiv EPOC headset had some

disadvantages, as the device was not used for clinical applications and therefore the accuracy of the registered signal was not very high.

The device also pre-processed the signals, so the obtained data was not really raw. Filtering the signals instead of improving the proposed method's efficiency – decreased it. This may be a result of removing some of the key information from the bio-signals.

Carried out literature study did not provide any information of using similar to proposed signal processing method.

## 8.2 Further Work

Future work carried out on this study should involve improving the accuracy of the obtained results. It would also be advisable to develop a standalone application (AE) that would not need PC, but would enable to connect the Emotiv EPOC headset with the TS-7260 with no need of MATLAB-based signal processing. Because of the implementation of the method based on basic mathematical operations – potential application of the signal processing onto the embedded platform would be possible, as the method does not require high computing or calculating power.

The further plan would be to implement the solution in order to enable efficient (and safe) control of a wheelchair.

Further, post-doctoral plans also involve building large database with EEG signals, which would be obtained from various devices and as a result – would enable developing better pattern-recognition method. As the use of Emotiv EPOC did not prove the headset to be a fully-satisfactory device for recording brain activity, further work on improving the customised electroencephalograph have been made.

There is also a high interest in implementing Raspberry PI platform for the research purposes. Unfortunately the system was not available during the study.

In Fig. 8.1 embedded platform Raspberry PI was presented. Fig. 8.2 shows a scheme of a newer, improved – B version. The device was developed by tam from the Cambridge University [122].



Figure 8.1: Raspberry PI [122].

## RASPBERRY PI MODEL B

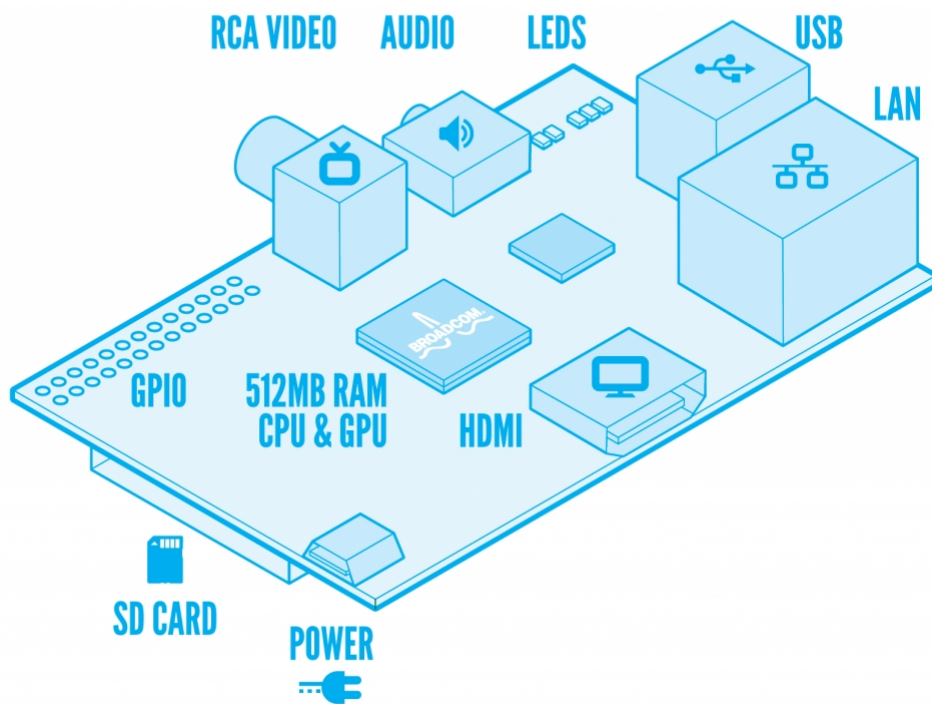
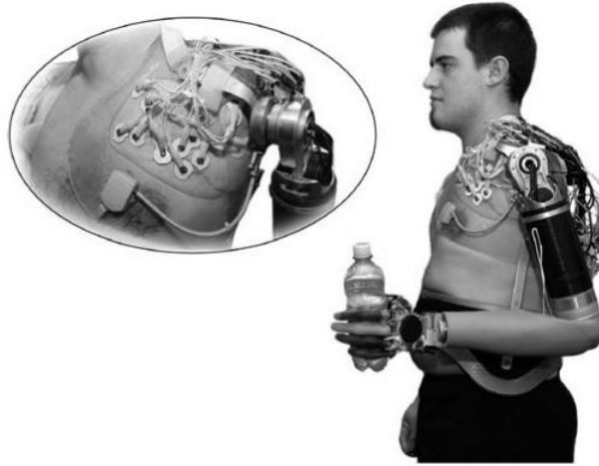


Figure 8.2: Raspberry PI – B – scheme [122].



**Figure 8.3:** Prosthetics with the implementation of TMR [6].

Possible implementation of Model B, which has 512Mb RAM, 2 USB port and an Ethernet port is considered. The small device runs at at least 700 MHz and there is an opportunity to over-clock the CPU. The device has computing capability of a typical PC computer, despite its very small dimensions [122].

There are also plans to advance the work in the way, that various (not only EEG) bio-signals could be used in order to extend the possible application of the proposed solution. Bio-signals such as voice, eye-movements or EMG would be implemented. The result may be used in order to improve prosthetics – such the one presented in Figure 8.3 ([6]).

The main aim of this work was and still is the idea of improvement quality of life of handicapped-users.

# References

- [1] Carroll J. M. (Ed.), *HCI Models, Theories and Frameworks: Toward a Multidisciplinary Science*. Morgan Kaufman, 2003.
- [2] Lazar J., Feng J. H., Hochheiser H., *Research Methods in Human-Computer Interaction*. John Wiley & Sons, 2010.
- [3] Wolpaw J. R., Wolpaw Winter E., *Brain-Computer Interfaces. Principles and Practice*. Oxford University Press Inc., 2012.
- [4] Kolb B., Whishaw I. Q., *An Introduction to Brain and Behavior*. Third Edition (International Edition), Worth Publishers, 2011.
- [5] Moghavvemi M., Tattaran A., Moshrefpour-Esfahani M. H., *EEG Artifact Signals Tracking and Filtering in Real Time for Command Control Application*. Editors: Noor Azuan A. O., Wan Abu Bakar W. A., Ahmad Khairi A. W., Hua-Nong T., IFMBE Proceedings, 5th Kuala Lumpur International Conference on Biomedical Engineering 2011, Volume 35, BIOMED 2011 – 20-23 June 2011, Kuala Lumpur, Malaysia, International Federation for Medical and Biological Engineering, Springer, 2011.
- [6] Graimann B., Allison B., Pfurtscheller G., *Brain-Computer Interfaces. Revolutionizing Human-Computer Interaction*. Springer Verlag, 2010.
- [7] Berger T. W., Chapin J. K., Gerhardt G. A., McFarland D. J., Principe J. C., Soussou W. V, Taylor D. M., Tresco P. A., *Brain-Computer Interfaces. An International Assessment of Research and Development Trends*. Springer, WTEC, 2008.

## REFERENCES

---

- [8] Tan D. S., Nijholt A., *Brain-Computer Interfaces. Applying our Minds to Human-Computer Interaction*. Springer-Verlag London Limited, 2010.
- [9] Schomer D. L., Lopes da Silva F. H., *Niedermeyer's Electroencephalography: Basic Principles, Clinical Applications, and Related Fields*. Lippincott Williams & Wilkins, 2010.
- [10] Dornhege G., Millan J. del R., Hinterberger T., McFarland D. J., Mueller K.-R., *Toward Brain-Computer Interfacing*. Massachusetts Institute of Technology, 2007.
- [11] He B., *Neural Engineering. Bioelectric Engineering – Volume Three*. Kluwer Academic Publishers, 2005.
- [12] Buzsaki G., *Rhythms of the Brain*. Oxford University Press, 2006.
- [13] Bear M. F., Connors B. W., Paradiso M. A., *Neuroscience. Exploring the brain*. Third Edition, Lippincott Williams & Wilkins, 2007.
- [14] Katz B.F, *Neuroengineering the Future*. Infinity Science Press LLC, 2008.
- [15] Garrett B., *Brain & Behavior. An Introduction to Biological Psychology*. Second Edition, Sage Publications Inc., 2009.
- [16] Hippe Z. S., Kulikowski J. L., Mroczek T., *Human-Computer Systems Interaction: Backgrounds and Applications 2. Part 1.* Springer-Verlag, Berlin Heidelberg, 2012.
- [17] McCullagh P. J., Ware M. P., Lightbody G., *Brain Computer Interfaces for Inclusion*. AH '10 Proceedings of the 1st Augmented Human International Conference, ACM New York, USA, 2010.
- [18] <http://www.bci2000.org>
- [19] Marchetti M., Piccione F., Silvoni S., Gamberini L., Priftis K., *Spatial Attention Orienting to Improve the Efficacy of a Brain-Computer Interface for Communication*. CHIItaly Proceedings of the 9th ACM SIGCHI, International Conference on Computer-Human Interaction: Facing Complexity, ACM, 2011.



## REFERENCES

---

- [20] Ashkan Y., Jong-Seok L., Touradj E., *Implicit Emotional Tagging of Multimedia Using EEG Signals and Brain Computer Interface*. WSM '09 Proceedings of the 1st SIGMM workshop on Social Media, ACM, 2009.
- [21] Aloise F., Schettini F., Arico P., Bianchi L., Riccio A., Mecella M., Babiloni F., Mattia D., Cincotti F., *Advanced Brain Computer Interface for Communication and Control*. AVI '10 Proceedings of the International Conference on Advanced Visual Interfaces, ACM, 2010.
- [22] <http://www.qualilife.com/>
- [23] Yuksel B. F., Donnerer M., Tompkin J., Steet A., *A Novel Brain-Computer Interface Using a Multi-Touch Surface*. CHI '10 Proceedings of the SIGCHI Conference on Human Factors in Computing Systems, ACM, 2010.
- [24] <http://www.gtec.at/>
- [25] Aloise F., Schettini F., Arico P., Bianchi L., Riccio A., Mecella M., Babiloni F., Mattia D., Cincotti F., *Advanced Brain Computer Interface for Communication and Control*. AVI '10 Proceedings of the International Conference on Advanced Visual Interfaces, ACM, 2010.
- [26] Lotte F. *Brain-Computer Interfaces for 3D Games: Hype or Hope?*. FDG '11 Proceedings of the 6th International Conference on Foundations of Digital Games, ACM, 2011.
- [27] Schmalstieg D., Bornik A., Mueller-Putz G., Pfurtscheller G., *Gaze-directed Ubiquitous Interaction Using a Brain-Computer Interface*. AH '10 Proceedings of the 1st Augmented Human International Conference, ACM, 2010.
- [28] Toyama J., Ando J., Kitazaki M., *Event-related De-synchronization and Synchronization (ERD/ERS) of EEG for Controlling a Brain-Computer-Interface Driving Simulator*. VRST '09 Proceedings of the 16th ACM Symposium on Virtual Reality Software and Technology, ACM, 2009.

## REFERENCES

---

- [29] Poor G. M., Leventhal L. M., Bowling S. K., Ringenberg J., Jaffee S. D., *Thought Cubes: Exploring the Use of an Inexpensive Brain-Computer Interface on a Mental Rotation Task*. ASSETS '11 The Proceedings of the 13th International ACM SIGACCESS Conference on Computers and Accessibility, ACM, 2011.
- [30] Bernays R., Mone J., Yau P., Murcia M., Gonzales-Sanchez J., Chavez-Echeagaray M. E., Christopherson R., Atkinson R., *Lost in the Dark: Emotion Adaption*. UIST Adjunct Proceedings '12 Adjunct Proceedings of the 25th Annual ACM Symposium on User Interface Software and Technology, ACM, 2012.
- [31] <http://www.emotiv.com/>
- [32] Vi C., Subramanian S., *Detecting Error-related Negativity for Interaction Design*. CHI '12 Proceedings of the SIGCHI Conference on Human Factors in Computing Systems, ACM, 2012.
- [33] [http://emotiv.wikia.com/wiki/Emotiv\\_EPOC](http://emotiv.wikia.com/wiki/Emotiv_EPOC)
- [34] Campbell A. T., Choudhury T., Hu S., Lu H., Mukerjee M. K., Rabbi M., Raizada R. D. S., *NeuroPhone: Brain-Mobile Phone Interface Using a Wireless EEG Headset*. MobiHeld '10: Proceedings of the second ACM SIGCOMM workshop on Networking, Systems, and Applications on Mobile Handhelds, August 2010, USA.
- [35] Gibert G., Pruzinec M., Schultz T., Stevens C., *Enhancement of Human Computer Interaction with Facial Electromyographic Sensors*. OZCHI '09 Proceedings of the 21st Annual Conference of the Australian Computer-Human Interaction Special Interest Group: Design: Open 24/7, ACM, 2009.
- [36] Naik G. R., Kumar D. K., Singh V. P., Palaniswmi M., *Hand Gestures for HCI using ICA of EMG*. VisHCI '06 Proceedings of the HCSNet Workshop on Use of Vision in Human-Computer Interaction - Volume 56, ACM, 2006.

- 
- [37] Li Y., Chen X., Tian J., Zhang X., Wang K., Yang J., *Automatic Recognition of Sign Language Subwords Based on Portable Accelerometer and EMG Sensors*. ICMI-MLMI '10 International Conference on Multimodal Interfaces and the Workshop on Machine Learning for Multimodal Interaction – Article No. 17, ACM, 2010.
- [38] Bulling A., Roggen D., Troester G., *It's in your Eyes: Towards Context-Awareness and Mobile HCI Using Wearable EOG Goggles*. UbiComp '08 Proceedings of the 10th International Conference on Ubiquitous Computing, ACM, 2008.
- [39] Xu S., Jiang H., Lau F. C. M., *User-Oriented Document Summarization through Vision-based Eye-Tracking*. IUI '09 Proceedings of the 14th International Conference on Intelligent User Interfaces, ACM, 2009.
- [40] Lagercrantz H., *The Newborn Brain. Neuroscience and Clinical Applications*. Second Edition, Cambridge University Press, 2010.
- [41] Ellis H., *Clinical Anatomy. Applied anatomy for students and junior doctors*. Blackwell Publishing, 2006.
- [42] The Society for Neuroscience, *Brain Facts. A primer on the brain and nervous system*. 2008 Third Edition.
- [43] Evans-Martin F.F., *(The Human Body How it works) The nervous system*. Infobase Publishing, 2010.
- [44] Waugh A., Grant A., *Anatomy and Physiology in Health and Illness*. Ross and Wilson, Ninth Edition, Churchill Livingstone, 2001.
- [45] Janiszewski L., Barbacka-Surowiak G., Surowiak J., *Neurofizjologia porównawcza*. Wydawnictwo Naukowe PWN, Warszawa, 1993.
- [46] Kosinski R. A., *Sztuczne sieci neuronowe. Dynamika nieliniowa i chaos*. Wydawnictwa Naukowo-Techniczne, Warszawa, 2004.
- [47] Tortora G.J., Nielsen M.T., *Principles of Human Anatomy*. 11th Edition, John Wiley & Sons, Incorporation, 2009.

## REFERENCES

---

- [48] Patton K. T., Thibodeau G. A., *Anatomy & Physiology*. Seventh Edition, Mosby Elsevier 2010.
- [49] Erber J., *Einfuehrung in die Neurobiologie (Student's script)*. Institut fuer Oekologie, Technische Universitaet Berlin, 2005.
- [50] Zmarzly D., *Pomiary elektrycznych wielkosci medycznych*. Skrypt Nr 268, Politechnika Opolska, Opole, 2005.
- [51] <http://www.new-technology-online.com/what-is-bioelectricity/>
- [52] [http://www.mind.ilstu.edu/curriculum/neurons\\_intro/neurons\\_intro.php/](http://www.mind.ilstu.edu/curriculum/neurons_intro/neurons_intro.php/)
- [53] <http://www.rnpedia.com/home/notes/medical-surgical-nursing-notes/nervous-system>
- [54] Diamond M. C., Scheibel A. B., Elson L. M., *The Human Brain Coloring Book*. HarperCollins Publishers Inc., New York, 2011.
- [55] Snell R. S., *Clinical Anatomy for Medical Students*. Fifth Edition, Lippincot Williams and Wilkins, 2001.
- [56] Nicholls J. G., Martin R. A., Wallace B. G., Fuchs P.A., *From Neuron to Brain*. Fourth Edition, Sinauer Associates Inc., Sunderland Massachusetts, USA, 2001.
- [57] Levitan I.B., Kaczmarek L.K., *The Neuron: Cell and Molecular Biology*. Oxford University Press, 2002.
- [58] von Neumann J., *The Computer and the Brain*. Yale University Press, New Haven and London, 2000.
- [59] Michailoff G.A., Briar Ch., *Crash Course: Nervous System*. Elsevier Mosby, 2005.
- [60] Snedden R., *Understanding the Brain and the Nervous System*. The Rosen Publishing Group Inc., 2010.

## REFERENCES

---

- [61] Nieuwenhuys R., Voogd J., van Huijzen Ch., *The human nervous system*. Springer Verlag, Berlin-Heidelberg 2008.
- [62] Noback Ch. R., Strominger N. L., Demarest R. J., Ruggiero D. A., *The Human Nervous System. Structure and Function*. Humana Press Inc., 2005.
- [63] O'Shea M., *The Brain. A very short introduction*. Oxford University Press, 2005.
- [64] <http://www.cod.edu/people/faculty/chenpe/>
- [65] <http://www.csuchico.edu/>
- [66] Saab C. Y., *The Spinal Cord*. Infobase Publishing, 2006.
- [67] Gutman S. A., *Quick Reference. Neuroscience for Rehabilitation Professionals: The Essential Neurologic Principles Underlying Rehabilitation Practice*. Second Edition, Slack Incorporated, 2008.
- [68] Clarke E., O'Malley C.D., *The Human Brain and Spinal Cord: A Historical Study Illustrated by Writings from Antiquity to the Twentieth Century*. Second Edition, Revised and Enlarged, Norman Publishing, 1996.
- [69] Kropotov J.D., *Quantitative EEG Event-Related Potentials and Neurotherapy*. First Edition, Elsevier Inc., 2009.
- [70] [http://www.mind.ilstu.edu/curriculum/neurons\\_intro/neurons\\_intro.php](http://www.mind.ilstu.edu/curriculum/neurons_intro/neurons_intro.php)
- [71] Brown A.G., *Nerve Cells and Nervous Systems. An Introduction to Neuroscience*. Second Edition, Springer-Verlag London Limited, 2001.
- [72] Tong S., Thakor N. V., *Quantitative EEG Analysis Methods and Clinical Applications*. Artech House, 2009.
- [73] Mulert C., Lemieux L., *EEG-fMRI: Physiological Basis, Technique and Applications*. Springer Verlag, 2010.
- [74] Berger H., *Über das Elektroenzephalogramm des Menschen*. Archiv Psychiatrischer Nervenkrankheiten, 1929.

## REFERENCES

---

- [75] Ullsperger M., Debener S., *Simultaneous EEG and FMRI. Recording, Analysis and Application*. Oxford University Press, 2010.
- [76] Andreassi J.L., *Psychophysiology. Human Behaviour & Physiological Response*. Fifth Edition, Lawrence Erlbaum Associates Inc., 2007.
- [77] Ward L. M., *Synchronous Neural Oscillations and Cognitive Processes*. Trends in Cognitive Sciences, Volume 7, Issue 12, Elsevier Ltd., 2003.
- [78] Kandel E. R., Schwartz J. H., Jessell T. M., *Principles of Neural Science*. Third Edition, Prentice-Hall International Inc., 1991.
- [79] Niedermeyer E., Lopes da Silva F., *Electroencephalography. Basic Principles, Clinical Applications and Related Fields*. Fifth Edition, Lippincott Williams & Wilkins 2005.
- [80] Sadock B.J., Kaplan H.I., Sadock V.A., *A Handbook for Yogasana Teachers: The Incorporation of Neuroscience, Physiology, and Anatomy into the Practice*. Wheatmark Inc., 2009.
- [81] Postawski K., *Cure Insomnia Quick* <http://www.cureinsomniaquick.com/Brainwaves-and-Brainwave-Entrainment.html>
- [82] Sadock B.J., Kaplan H.I., Sadock V.A., *Kaplan & Sadock's Synopsis of Psychiatry: Behavioral Sciences/Clinical Psychiatry*. Tenth Edition, Lippincott Williams & Wilkins, 2007.
- [83] Steriade M., Gloor P., Llinas R. R., Lopes da Silva F. H., Mesulam M.-M., *Basic Mechanisms of Cerebral Rhythmic Activities*. Electroencephalography and Clinical Neurophysiology, Report of IFCN Committee on Basic Mechanisms, Elsevier Scientific Publishers Ireland Ltd., 1990.
- [84] Stern J.M., Engel (Jr.) J., *Atlas of EEG patterns*. First Edition, Lippincott Williams & Wilkins, 2004.
- [85] Geetha G., Geethalakshmi S. N., *Scrutinizing different techniques for artifact removal from EEG signals*. International Journal of Engineering Science and Technology (IJEST), Vol 3. No. 2, 2011.

## REFERENCES

---

- [86] Geetha G., Geethalakshmi S. N., *EEG De-noising using SURE Thresholding based on Wavelet Transforms*. International Journal of Computer Applications, Vol 24. No. 6, 2011.
- [87] Rong F., *Memory-related cognitive modulation of human auditory cortex: Magnetoencephalography-based validation of a computational model*. <http://drum.lib.umd.edu/bitstream/1903/8064/1/umi-umd-5225.pdf> Department of Kinesiology, School of Public Health, University of Maryland, 2008.
- [88] Parks T.W., Burrus C.S., *Digital Filter Design*. John Wiley & Sons, New York, 1987.
- [89] Bagchi S., Mitra S. K., *The Nonuniform Discrete Fourier Transform and its Applications in Signal Processing*. Kluwer Academic Publishers, 1999.
- [90] Zielinski T.P. , *Cyfrowe Przetwarzanie Sygnałów. Od Teorii do Zastosowań*. Wydawnictwo Komunikacji i Łączności (WKL), Warszawa, 2005.
- [91] Miao G. J. Clements M. A., *Digital Signal Processing and Statistical Classification*. Artech House Inc., 2002.
- [92] Taylor F. J., *Digital Filters. Principles and Applications with MATLAB*. IEEE Press, John Wiley & Sons Inc., 2012.
- [93] Ingle V. K., Proakis J. G., *Essentials of Digital Signal Processing Using MATLAB*. International Edition, Third Edition, Cengage Learning, 2012.
- [94] Baby Deepa V., Thangaraj P., *A study on classification of EEG Data using the Filters*. International Journal of Advanced Computer Science and Applications (IJACSA), Vol. 2, No. 4, 2011.
- [95] Art Chaovalitwongse W., Suharitdamrong W., Pardalos P. M., *Time-Frequency Analysis of Brain Neurodynamics*. Editors: Gao D. Y., Sherali H. D., Advances in Applied Mathematics and Global Optimization. In honor of Gilbert Strang, Advances in Mechanics and Mathematics, Vol. 17, Springer Science, 2009.

- 
- [96] Antoniou A., *Digital Signal Processing*. McGraw-Hill, Canada, 2006.
- [97] Song L., Epps J., *Classifying EEG for Brain-Computer Interface: Learning Optimal Filters for Dynamical System Features*. Journal Computational Intelligence and Neuroscience – Brain-Computer Interfaces: Towards Practical Implementations and Potential Applications Archive, 2007.
- [98] Mahajan K., Vargantwar M. R., Rajput S. M., *Classification of EEG using PCA, ICA and Neural Network*. International Journal of Engineering and Advanced Technology (IJEAT), Vol. 1, Issue 1, 2011
- [99] Zhang X., Yin L., *Wavelet Time-frequency Analysis of Electroencephalogram (EEG) Processing*. (IJACSA) International Journal of Advanced Computer Science and Applications, Vol. 1, No. 5, November 2010.
- [100] Li C. S., Wang H., *Wavelet transform for on-off switching BCI device*. IIFMBE Proceedings, Springer-Verlag Berlin Heidelberg, 2008.
- [101] Khan A., A., *Digital signal processing fundamentals*. Da Vinci Engineering Press, 2005.
- [102] Teolis A., *Computational Signal Processing with Wavelets*. Birkaeuser Boston, 1998.
- [103] Kaiser A. H., *Digital Signal processing using the Fast Fourier Transform (FFT)*. Scholarly Paper, 1st Edition, GRIN Verlag 1997.
- [104] Orłowski P., *Zastosowanie notacji operatorowej i uproszczonych metod czestotliwosciowych do niestacjonarnych ukladow dyskretnych w zagadnieniach analizy systemow i sterowanie. (Eng.: Application of Operator Notation and Simplified Frequency Methods to Non-Stationary Discrete Systems in Issues Related to System Analysis and Control)*. Zachodniopomorski Uniwersytet Technologiczny w Szczecinie, Szczecin 2011.
- [105] Onton J., Makeing S., *High-frequency Broadband Modulations of Electroencephalographic Spectra*. Front Hum Neurosci. 2009; 3: 61, PMC2806183, 2009.



## REFERENCES

---

- [106] Naik G. R., Kumar D. K., *An Overview of Independent Component Analysis and Its Applications*. Informatica: An International Journal of Computing and Informatics, No. 35, 2011.
- [107] <http://www.sccn.ucsd.edu>
- [108] Richardson M., *Prinicipal Component Analysis*. 'Special Topic', University of Oxford, 2009.
- [109] <http://www.bbci.de>
- [110] <http://www.electronics-lab.com/downloads/schematic/013/index.html>
- [111] Nuwera M. R., Comib G., Emersonc R., Fuglsang-Frederiksend A., Guerite J. M., Hinrichsf H., Ikedag A., Luccash F., Rappelsburgeri P., *IFCN Standards for Digital Recording of Clinical EEG*. Electroencephalography and Clinical Neurophysiology Vol. 106, Elsevier Science Ireland Ltd., 1998.
- [112] <http://www.ifcn.info/showcontent.aspx?MenuID=1133>
- [113] <http://www.contecmed.com>
- [114] <http://engineering.wordpress.com>
- [115] <http://www.nihonkohden.de/index.php?id=215&L=1>
- [116] Enoka R. M., *Neuromechanics of Human Movement*. Fourth Edition, Human Kinetics, 2008.
- [117] Latash M., *Neurophysiological Basis of Movement*. Human Kinetics, 1998.
- [118] <http://www.embeddedarm.com/products/board-detail.php?product=TS-7260>
- [119] Howell W.H., Fulton I. F., *Physiology and Biophysics. The Brain and Neural Function*. W. B. Saunders Company, 1979.
- [120] Dyson F., *The Best American Science and Nature Writing*. Houghton Mifflin Harcourt Publishing Company, 2010.

## REFERENCES

---

- [121] Seigneur J.-M., *The Emotional Economy for the Augmented Human*. AH '11 Proceedings of the 2nd Augmented Human International Conference, ACM, 2011.
- [122] <http://www.raspberrypi.org/>

# Appendix A

## Participant Information

In this part of Appendix is attached the information, which was given to the participant of the experiments.

## **Research Information for Participants**

### *EFFICIENCY EVALUATION OF EXTERNAL ENVIRONMENTS CONTROL USING BIO-SIGNALS*

My name is Aleksandra KAWALA-JANIK and I am working towards my PhD at the Computing and Mathematical Sciences School at the University of Greenwich.

I have moved to Greenwich from Ph.D. studies at another institution, the Opole University of Technology, Poland, in which during the three year's research conducted I gained knowledge related to bio-signals analysis and recognition. Based on this work, I have gathered relevant test data for the analysis purpose.

#### **A FEW WORDS ABOUT THE RESEARCH**

The main question posed by the research is whether it is possible to use various bio patterns (such as brain waves signals, speech signals, etc.) for the purpose of controlling a human's environment. Another question is related to the problem of identification of the most efficient bio signals for some specific applications.

Recently the kind of research undertaken in this project is becoming more and more popular. This is due to the fact that increased processing power of ubiquitous (embedded) systems has reached the level enabling real-time processing of very complex signals, including human's brain waves, speech signal, etc.

In this project, various bio signals / bio patterns will be investigated from the point of view of their usability for the purpose of controlling human's external environment – as an alternative to a mouse or keyboard with personal computers. The most efficient signals will be identified and an example demonstration application will be developed showing the solution found in operation.

#### **PARTICIPATION IN THE RESEARCH**

- Participant can withdraw from the research at any time
- Participation is voluntary
- The character of the research is non-invasive and pain free
- It is based on electroencephalography
- The signal will be a just a file without any information about the participants

- In case of necessity - other data (than signal itself) will be gathered using an anonymous questionnaire, filled in electronically, compressed and password protected (to comply with Data Protection)

The gathered information will be destroyed shortly after the research. No information about the participants will be included in the final dissertation. It will be impossible to identify the participants.

### **DESCRIPTION OF THE RESEARCH**

- The research will take place at the University of Greenwich, Computer and Mathematical Sciences School.
- The research will take no more than 10 minutes.
- The device will be connected to laptop supplied by batteries and unplugged to suppress the risk of electrical shock

The participant will have to imagine moving left or right hand, while the signal will be gathered with the device presented in the Figure 1.



Fig. 1. The device used in the research will be the Emotiv.

Further information about the 'Emotiv' device can be found on the following website:

<http://emotiv.com/>

### **CONTACT DETAILS**

#### **INVESTIGATOR:**

Mrs. Aleksandra Kawala-Janik  
QM440  
e-mail: a.d.kawala-janik@greenwich.ac.uk

#### **SUPERVISOR:**

Dr. Richard Anthony  
QM414  
e-mail: r.j.anthony@greenwich.ac.uk

# Appendix B

## Selected Papers

Below is the list of chosen publications in relation to the dissertation topic:

1. "Zastosowanie pomiarów elektroencefalograficznych EEG w procesie uwierzytelniania biometrycznego użytkowników" Sz. Paszkiel, D. Zmarzły, A. Kawala, M. Szmechta. Miesięcznik naukowo-techniczny Pomiary, Automatyka, Kontrola - PAK. Vol. 53 BIS 92007, Warszawa.
2. "Brain-Computer Interface New Trend in Science" A. Kawala, V. Khoma, D. Zmarzły, Y. Sovyn. Conference Proceedings – 5th International Conference New Electrical and Electronic Technologies and their Industrial Implementation NEET 2007. Zakopane.
3. "Przegląd metod sterowania maszynami przy użyciu sygnałów myślowych" A. Kawala, V. Khoma, D. Zmarzły, Y. Sovyn. Przegląd Elektrotechniczny. ISSN 0033-2097, no. 3/2008. (**ATTACHED**)
4. "Zastosowanie elektroencefalografii oraz prowadzenie symulacji poprawności zachowań w procesie komunikacji Brain Computer Interface" Sz. Paszkiel, D. Zmarzły, A. Kawala. Conference Proceedings – Podstawowe Problemy Metrologii 2008 PPM2008. Sucha Beskidzka.

- 
5. "The influence of artefacts on the control of a computer in the BCI communication" Sz. Paszkiel, D. Zmarzly, A. Kawala. International Conference – IC-SPETO 2008. Ustron.
  6. "Analysis of evoked potentials and their use in brain-computer interfaces" A. Kawala, D. Zmarzly, Sz. Paszkiel. International Conference IC-SPETO 2008. Ustron.
  7. "Active electrode for Brain-Computer Interfaces" A. Kawala, D. Zmarzly, Sz. Paszkiel. International Conference IC-SPETO 2008. Ustron. (**ATTACHED**)
  8. "Zastosowanie fali P300 w nieinwazyjnych interfejsach BCI" A. Kawala. Zeszyt naukowy doktorantw, Srodowiskowe Warsztaty Doktorantw 2008. Jarnoltwek. (**ATTACHED**)
  9. "Time-Frequency Analysis of EEG Signals" A. Kawala. Zeszyt naukowy doktorantw, Srodowiskowe Warsztaty Doktorantw 2009. Glucholazy. (**ATTACHED**)
  10. "Spectral Analysis of EEG Signals" A. Kawala-Janik. III International Interdisciplinary Technical Conference of Young Scientists 2010. Poznan.
  11. "The use of double filtration in analysis of EEG signals" A. Kawala. Zeszyt naukowy doktorantw, Srodowiskowe Warsztaty Doktorantw 2010. Glucholazy.
  12. "Human-Computer Interface based on novel filtering algorithm and the implementation of the Emotiv EPOC headset" A. Kawala-Janik, M. Pelc, R. Anthony, J. Hawthorne, J. Ma International Conference – IC-SPETO 2012 – accepted for the conference. (**ATTACHED**)

## Przegląd metod sterowania maszynami przy użyciu sygnałów myślowych

**Streszczenie:** W artykule przedstawiono charakterystykę inwazyjnych i nieinwazyjnych interfejsów mózg-maszyna oraz ich zastosowanie. Na obecnym etapie badań występuje szereg trudności technicznych, które ograniczają rozwój gotowych aplikacji. Przewiduje się wiele zastosowań tego typu interfejsów, począwszy od pomocy osobom chorym i niepełnosprawnym, użytkowników aplikacji komputerowych aż po sterowanie maszynami, procesami przemysłowymi czy urządzeniami gospodarstwa domowego.

**Abstrakt:** In the paper the characteristics of invasive and non-invasive methods of brain-computer interfaces and their adaptations are presented. This field of science has greatly evolved recently. At the current level of researches there are a number of technical difficulties that limit further development of existing applications. It is foreseen to use those applications to help physically handicapped patients or just to control various kinds of machines. (Invasive and non-invasive methods of brain-computer interfaces).

**Słowa kluczowe:** interfejs człowiek-komputer, sterowanie, BCI inwazyjne, BCI nieinwazyjne, sygnały aktywności mózgu.

**Keywords:** brain-computer interface, brain-machine interface, invasive BCI, non-invasive BCI, brain's activity signals.

### Wprowadzenie

Sterowanie urządzeniami za pomocą myśli jest zagadnieniem interdyscyplinarnym i łączy nauki medyczne, w szczególności neurobiologię z elektroniką i informatyką. Główną przyczyną zainteresowania tą tematyką są potencjalnie duże możliwości wykorzystania w różnych dziedzinach wiedzy. Na obecnym etapie badań do sprzęgania mózgu z komputerem BCI (Brain-Computer Interface) lub BMI (Brain-Machine Interface) wykorzystywane są odpowiednie sygnały pochodzące od aktywności mózgowej. Są to sygnały elektryczne [1, 2, 3, 4], magnetyczne [5], metaboliczne [6, 7, 8] a nawet optyczne [9]. Sygnały te aktywują urządzenia zewnętrzne, takie jak komputery, przełączniki czy protezy [1, 10, 11, 12].

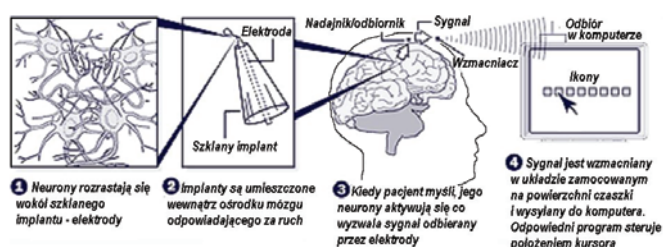
### Przegląd interfejsów BCI

Do sprzęgania mózgu z komputerem wykorzystuje się dwa rodzaje BCI.– inwazyjne oraz nieinwazyjne. Metody inwazyjne wymagają wszczępienia elektrod bezpośrednio do mózgu, co związane jest z koniecznością operacji chirurgicznej i może powodować szereg komplikacji. Metody nieinwazyjne są bezpieczne, ale wymagają bardziej złożonych układów pomiarowych.

### BCI inwazyjne

Inwazyjne BCI polegają na bezpośrednim wszczępieniu elektrod do komórek nerwowych lub umieszczeniu ich pod czaszką, na powierzchni mózgu (elektrokortygrafia) [13]. Jednym z typowych przykładów wykorzystania tego rodzaju interfejsów jest przywracanie utraconych zdolności motorycznych. Zadanie to polega na użyciu sygnałów emitowanych przez mózg do adaptacji urządzeń zewnętrznych, np. protez oraz sterowanie nimi za pomocą myśli. W pracy Schwarza [11] opisano elektrodę wszczepioną do mózgu małpy człekokształtnej, do której podłączono protezę – mechaniczną rękę. Po krótkim treningu zwierzę było w stanie używać protezy do podawania sobie pokarmu. Początkowo będąc świadomą użycia sztucznej kończyny, po pewnym czasie (w skutek treningu) zaczęło ją traktować jako dodatkową, własną kończynę, sterowaną tylko i wyłącznie „siłą woli”.

Implanty wszczepia się również ludziom. W niektórych przypadkach elektrody mogą powodować powstawanie lokalnych stref nieczułości, wokół elektrod, blokujących przepływ impulsów elektrycznych. Schemat blokowy interfejsu wykorzystującego implanty wszczepione w obrębie ośrodka ruchu przedstawiono na rysunku 1.



Rys. 1. Schemat blokowy działania inwazyjnego interfejsu mózg-komputer [14]



Rys. 2. Matthew Nagle – pierwszy pacjent z wszczepionym implantem wykorzystywanym do sterowania urządzeniami [14]

Niedawno zezwolono w USA na pierwszą próbę pomocy takiej osobie. Matthew Nagle (rys. 2) był pierwszym pacjentem, któremu wszczepiono wieloelektrodową matrycę elektrod do mózgu (Cyberkinetics) [14]. Do czubka czaszki podłączono dekodery oraz wyprowadzenia elektrod. Pacjent jest w stanie wykonywać proste czynności, takie jak gaszenie i zapalanie światła oraz zmienianie kanałów w telewizji. Osoba ta posługuje się także specjalną neuroprotezą ramienia. Kiedy mężczyzna myśli „teraz zegnę palce” – sztuczna dłoń wykonuje to polecenie.

Innym kierunkiem badań są próby poprawiania, lub naprawiania uszkodzonej pamięci [15, 16]. W wielu ośrodkach pracuje się nad możliwością zastąpienia układem elektronicznym części mózgu zwanej hipokampem. Człowiek pozbawiony tego fragmentu tkanki nerwowej wszystkie nowe doświadczenia pamięta, co



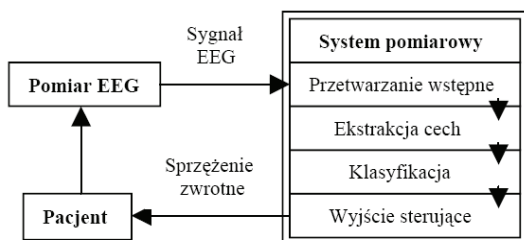
najwyżej przez kilka dni. Wszczepienie elektronicznego hipokampu umożliwia odzyskanie zdolności trwałego zapamiętywania. Funkcjonowanie hipokampu nie jest całkowicie wyjaśnione.

Znanych jest szereg modeli matematycznych, otrzymanych w wyniku identyfikacji. Jako sygnały wejściowe stosuje się najczęściej sygnały stochastyczne o charakterystyce impulsowej. Wykonano również neuronoprotezy oparte na modelu hipokampu. W tym przypadku wykonywano jedynie doświadczenia na zwierzętach [2, 6, 16].

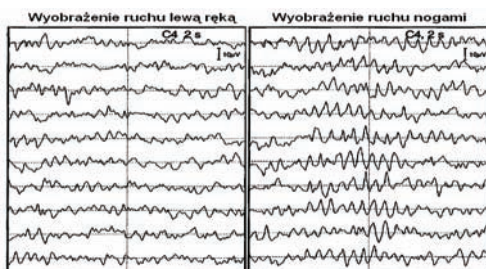
Implant symulujący hipokamp nie musi posiadać wszystkich jego fizjologicznych funkcji. Potrzebna jest jedynie zdolność wiernego kopiowania czynności elektrycznej. Praca mózgu wspomagana medykamentami uzupełnia ograniczenia w funkcjonowaniu sztucznego hipokampu.

### BCI nieinwazyjne

Nieinwazyjne metody sprzęgania mózgu z komputerem mają potencjalnie większe możliwości zastosowania w porównaniu z interfejsami ingerującymi w organizm człowieka. Są to metody również tańsze, choć wymagają bardziej złożonych układów pomiarowych. Nie ma również ograniczeń etycznych, co do stosowania elektrod powierzchniowych. Wyróżnia się cztery techniki nieinwazyjnego BCI: elektroencefalografia (EEG) [1, 2, 3, 4, 7, 18, 19, 20], w której mierzy się projekcję pochodzącą od aktywności dużej ilości neuronów w warstwach zewnętrznych mózgu (głównie z warstwy piramidowej zewnętrznej), magnetoencefalografia (MEG) [5], w której wykorzystuje się składową magnetyczną fali elektromagnetycznej pochodzącej od aktywności mózgu. Do pozostałych metod należą technika rezonansu magnetycznego (fMRI) [6, 7] oraz metoda pozytronowa (PET) [8]. Obecnie najpopularniejszą i dającą najlepsze rezultaty jest technika detekcji i analizy EEG.



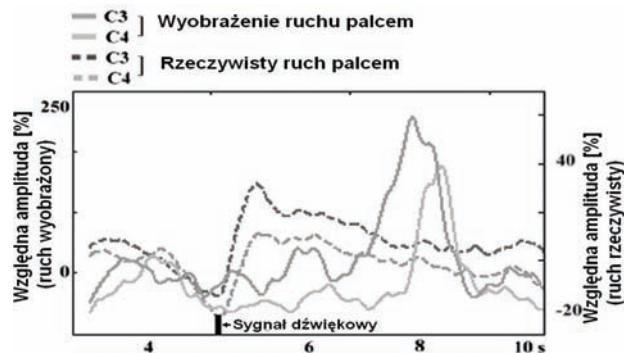
Rys. 3. Schemat blokowy działania nieinwazyjnego BCI przy użyciu sygnału EEG [2]



Rys. 4. Przebiegi czasowe sygnałów zmierzonych z wyprowadzenia C4 podczas wyobrażenia ruchu lewą ręką oraz obiema nogami [10]

Sygnał EEG mierzony jest przy użyciu elektrod rozmieszczonych na powierzchni głowy pacjenta. Przykładowe przebiegi czasowe sygnałów EEG zmierzonych dla wyobrażenia ruchu ręką oraz nogami przedstawiono na rysunku 4 [10]. Dane pomiarowe są

przetwarzane w celu ekstrakcji charakterystycznych cech dystyngtywnych. Przetwarzanie wstępne polega najczęściej na filtracji w dziedzinie częstotliwości w różnych pasmach, odpowiadających fizjologicznym przedziałom występowania fal różnego typu (alfa, beta, theta i in.).



Rys. 5. Przebiegi czasowe sygnału EEG (sygnał odfiltrowany w paśmie beta 20-24 Hz) dla wyobrażenia ruchu prawym palcem wskazującym oraz dla rzeczywistego ruchu tym samym palcem; przebiegi pokazano dla elektrod C3 i C4 [17]

Na rysunku 5 przedstawiono przebiegi czasowe EEG odfiltrowane w paśmie beta znormalizowane względem chwilowej wartości średniej dla wyobrażenia ruchu palcem [17]. Przebiegi porównano z przebiegami sygnału podczas faktycznie wykonanego ruchu.

Do parametryzacji wykorzystuje się albo przekształcenia Fouriera albo przekształcenie falkowe (ciągłe bądź dyskretne) z różnymi typami falek [6, 17, 20]. Zdekomponowany sygnał jest bezpośrednio podawany do klasyfikatora. Do często stosowanych parametrów należą również współczynniki modelu autoregresyjnego sygnału EEG [7, 8, 19]. Do klasyfikacji stosuje się algorytmy parametryczne lub nieparametryczne oraz metody wykorzystujące sztuczne sieci neuronowe [6, 22, 23, 24, 25, 26]. Przykładowy system sterowania robotem wykorzystujący klasyfikator neuronowy przedstawiono na rysunku 6 [6].

Skuteczność działania interfejsów BCI może wahać się w granicach od 60 do 95%. Na skuteczność nie wpływają takie czynniki jak inteligencja, płeć czy wiek. Sądzi się, że duże znaczenie mogą mieć fizjologiczne i anatomiczne różnice w budowie kory mózgowej, ale tego rodzaju badania są trudne do przeprowadzenia [6].



Rys. 6. Sterowanie myślowe robotem w mini-labiryncie [6]

### Podsumowanie

W artykule omówiono możliwości komunikacji człowieka z urządzeniami elektronicznymi za pomocą myśli. Omówiono metody inwazyjne oraz nieinwazyjne. Te ostatnie są w większym stopniu rozwijane ze względu na mniejsze zagrożenie dla potencjalnych użytkowników oraz niższy koszt. Do najczęściej stosowanych sposobów

reprezentacji sygnałów myślowych należy elektroencefalografia. W szczególności wykorzystuje się rytm fal, które odwzorowują wyobrażenia ruchowe. Skuteczność klasyfikacji sygnałów myślowych jest stosunkowo duża (do 95%), ale dla niewielkiej ilości klas rozpoznawanych (od 2 do 5 zadań myślowych). Głównym problemem ograniczającym rozwój BCI jest duża ilość sygnałów zakłócających [27, 28], zarówno pochodzących od źródeł zewnętrznych jak i pochodzących od fizjologicznych czynności człowieka (artefakty ruchowe, oczopląs, EKG itp.).

#### LITERATURA

- [1] Moore M.M., Mason S.G., Birch G.E., Analyzing Trends in Brain Interface Technology: A Method to Compare Studies: *Annals of Biomedical Engineering*, Vol. 34, No. 5, 2006, 859-878
- [2] Mason S.G., Moore M.M., Birch G.E., A General Framework for Characterizing Studies of Brain Interface Technology, *Annals of Biomedical Engineering*, Vol. 33, No. 11, 2005, 1653-1670
- [3] Andersen R.A., Musallam S., Pesaran B., Selecting the signals for a brain-machine interface, *Current Opinion in Neurobiology*, Vol. 14, 2004, 720-726
- [4] Greenfield S.A., Biotechnology, the brain and the future, *Trends in Biotechnology*, Vol. 23 No.1, 2005, 34-41
- [5] Georgopoulos A.P., Langheim F.J., Leuthold C., Merkle A.N., Magneto-encephalographic signals predict movement trajectory in space, *Exp Brain Res*, Vol. 25, 2005, 132-135
- [6] Millán J.R., Renkens F., Mourino J., Gerstner W., Brain-actuated interaction, *Artificial Intelligence* Vol. 159, 2004, 241-259
- [7] Cincotti F., Babiloni F., Mattiocco M., Astol L.S., Marciani M.G., Mattia D., Laboratory of functional neuroelectrical imaging and brain-computer interfacing at Fondazione Santa Lucia, *Cogn Process*, Vol. 6, 2005, 75-83
- [8] Kleber B., Birbaumer N., Direct brain communication: neuroelectric and metabolic approaches at Tübingen, *Cogn Process*, Vol. 6, 2005, s. 65-74
- [9] Koizumi H., Maki A., Yamamoto T., Sato H., Yamamoto Y., Kawaguchi H., Non-invasive brain-function imaging by optical topography, *Trends in Analytical Chemistry*, Vol. 24, No. 2, 2005, 147-157
- [10] Krausz G., Scherer R., Korisek G., Pfurtscheller G., Critical Decision-Speed and Information Transfer in the "Graz Brain-Computer Interface", *Applied Psychophysiology and Biofeedback*, Vol. 28, No. 3, 2003, 233-240
- [11] Schwartz A.B., Taylor D.M., Tillery S.I.H., Extraction algorithms for cortical control of arm prosthetics. *Curr Opin Neurobiol*, Vol. 11, 2001, 701-708
- [12] Schaal S., Schweighofer N., Computational motor control in humans and robots, *Current Opinion in Neurobiology*, Vol. 15, 2005, 675-682
- [13] Lal T.N., Hinterberger T., Widman G., Schroeder M., Hill J., Rosentiel W., Elger C.E., Schoelkopf B., Birbaumer N., Methods Towards Invasive Human Brain Computer Interfaces, *Workshop on Verification, Validation and Testing of Learning Systems, NIPS-2004*, British Columbia, 2004, 1-8
- [14] Martin R., Mind Control, *Wired Magazine*, Vol. 13, No. 3, 2005, 1-5
- [15] Matsumoto G., Tsujinob H., Design of a brain computer using the novel principles of output-driven operation and memory-based architecture, *International Congress Series* 1250, 2003, 529-546
- [16] Arbib M.A., Fellous J.M., Emotions: from brain to robot, *Trends in Cognitive Sciences* Vol. 8 No. 12, 2004, 554-561
- [17] Hung C., Lee P., Wu Y., Chen L., Yeh T., Hsieh J., Recognition of Motor Imagery Electroencephalography Using Independent Component Analysis and Machine Classifiers, *Annals of Biomedical Engineering*, Vol. 33, No. 8, 2005, 1053-1070
- [18] Shenoy P., Rao R.P.N., Dynamic Bayesian Networks for Brain-Computer Interfaces, *Workshop on Verification, Validation and Testing of Learning Systems, NIPS-2004*, British Columbia, 2004, s. 670-677
- [19] Neuper C., Mueller G.R., Kuebler A., Birbaumer N., Pfurtscheller G., Clinical application of an EEG-based brain-computer interface: a case study in a patient with severe motor impairment, *Clinical Neurophysiology*, Vol. 114, 2003, 399-409
- [20] Cremades J.G., Barreto A., Sanchez F., Adjouadi D., Human-computer interfaces with regional lower and upper alpha frequencies as on-line indexes of mental activity, *Computers in Human Behavior*, Vol. 20, 2004, 569-579
- [21] Zmarzły D., *Pomiary elektrycznych wielkości medycznych, Oficyna Wydawnicza Politechniki Opolskiej*, Nr 268, 2005
- [22] Begg R., Kamruzzaman J., A machine learning approach for automated recognition of movement patterns using basic, kinetic and kinematic gait data, *Journal of Biomechanics*, Vol. 38, 2005, 401-408
- [23] Ferdinando A., Mussa-Ivaldi F.A., Miller L.E., Brain-machine interfaces: computational demands and clinical needs meet basic neuroscience, *Trends in Neurosciences* Vol.26 No.6, 2003, 329-335
- [24] Newell K.M., Liu Y.T., Mayer-Kress G., Learning in the brain-computer interface: insights about degrees of freedom and degeneracy from a landscape model of motor learning, *Cogn Process*, Vol. 6, 2005, 37-47
- [25] Perelman Y., Ginosar R., Analog frontend for multichannel neuronal recording system with spike and LFP separation, *Journal of Neuroscience Methods*, Vol. 153, 2006, 21-26
- [26] Zeigler B.P., The brain-machine disanalogy revisited, *BioSystems*, Vol. 64, 2002, 127-140
- [27] Hollenberg B.A., Richards C.D., Richards R., Bahr D.F., Rector D.M., A MEMS fabricated flexible electrode array for recording surface field potentials, *Journal of Neuroscience Methods*, Vol. 153, 2006, 147-153
- [28] Yamasaki H., The future of sensor electronics, *Sensor and Actuators Nr. A56*, 1996, 129-133

#### Authors:

Aleksandra Kawala, dr hab. inż. Dariusz Zmarzły, prof. PO, Politechnika Opolska, Instytut Elektroenergetyki, ul. Prószkowska 76, 46-078, Opole, E-mail: [kawala84@yahoo.de](mailto:kawala84@yahoo.de); E-mail: [dariusz@zmarzly.com](mailto:dariusz@zmarzly.com); prof.dr hab.inż. Volodymyr Khoma, Politechnika Opolska, Instytut Automatyki i Informatyki, ul. K. Sosnkowskiego 31, 45-272 Opole, E-mail: [xoma@wp.pl](mailto:xoma@wp.pl); dr inż. Yaroslav Sovyn, Lviv Polytechnic National University, Institute of Computer Technologies, Automations and Metrology, 28A Bandera str., 79013 Lviv, Ukraine, E-mail: [ysovyn@yandex.ru](mailto:ysovyn@yandex.ru).

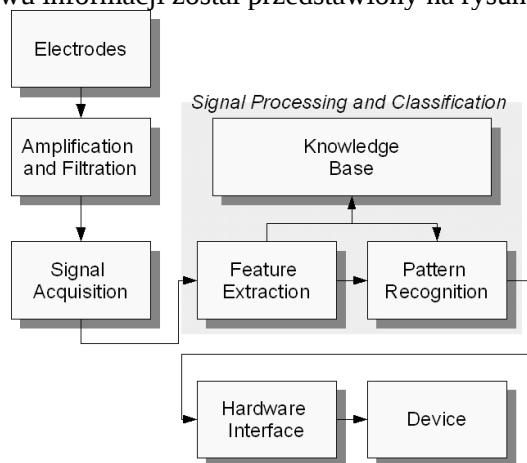
**Aleksandra Dagmara Kawala**

Wydział Elektrotechniki, Automatyki i Informatyki  
Instytut Elektroenergetyki

## ZASTOSOWANIE FALI P300 W NIEINWAZYJNYCH INTERFEJSACH BCI

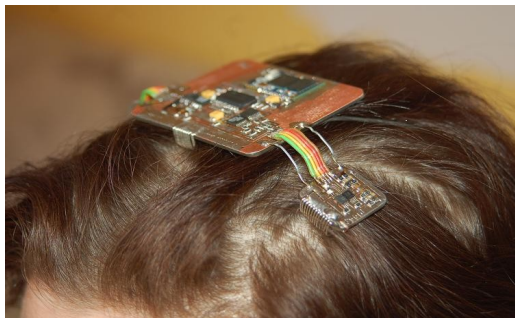
**Abstract:** Paper treats about the idea of direct communication between human and computer or another mechanical device. This communication called BCI is based on analysing brain waves such as event-related potential (ERP) P300 as a control signal in brain-computer interfaces.

BCI, czyli interfejs pomiędzy mózgiem a komputerem, jest systemem komunikacyjnym, działającym w czasie rzeczywistym, umożliwiającym wysyłanie komend do urządzenia zewnętrznego przy pomocy sygnałów myślowych [1,2]. Przykładem zastosowania BCI jest przywracanie funkcji motorycznych osobom sparaliżowanym [1-5]. Autorka artykułu zajmuje się projektem i konstrukcją interfejsu BCI bazującego na elektroencefalografii, który umożliwi sterowanie urządzeniem lub wyświetlanie wybranych elementów na ekranie komputera po przetworzeniu sygnałów pochodzących z elektrycznej aktywności mózgowej. Brain-Computer Interface będący podmiotem pracy naukowej autorki bazuje analizie potencjału wywołanego, skorelowanego z pobudzeniem, fali P300 i wykorzystaniu tej analizy w procesie sterowania urządzeniem mechanicznym. Mechanizm działania opiera się na wyobrażeniu czynności motorycznych i porównaniu wykresów powstałych w wyniku rejestracji faktycznych ruchów. Pomiary zostaną uśrednione, a proces rozpoznawania będzie oparty na algorytmie nieparametrycznym. Schemat blokowy przepływu informacji został przedstawiony na rysunku nr 1.

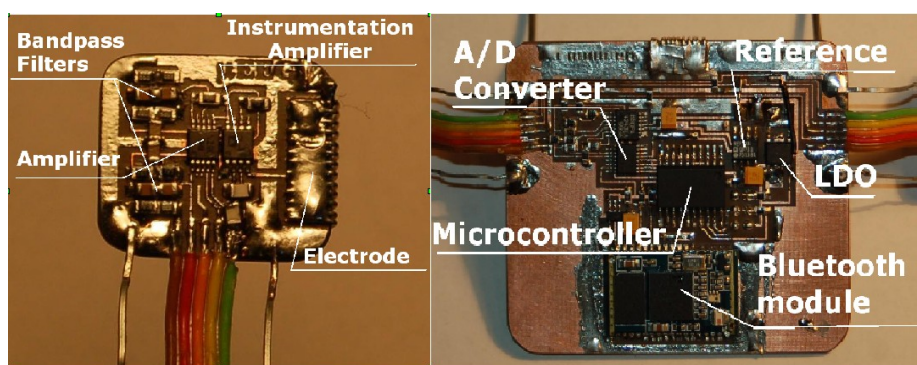


Rys. 1. Diagram przepływu informacji w interfejsie BCI [praca własna].

Autorka zaprojektowała i skonstruowała urządzenie pomiarowe – dwukanałowy elektroencefalograf widoczny na rysunku nr 2. Urządzenie składa się z dwóch elektrod aktywnych i modułu kontrolującego (rys. 3).



Rys. 2. Dwukanałowe EEG na głowie pacjentki [praca własna].



Rys. 3. Elektroda aktywna (lewa strona) i moduł kontrolujący (prawa strona) [praca własna].

## LITERATURA

- [1] Allison, Brendan Z.; Pineda, Jaime A., Effects of SOA and flash pattern manipulations on ERPs, performance, and preference: Implications for a BCI system. *International Journal of Psychophysiology* Volume: 59, Issue: 2, February, 2006, pp. 127-140
- [2] Birbaumer, Niels, Brain-computer-interface research: Coming of age. *Clinical Neurophysiology* Volume: 117, Issue: 3, March, 2006, pp. 479-483
- [3] McFarland, Dennis J.; Wolpaw, Jonathan R., EEG-Based Communication and Control: Speed-Accuracy Relationships. *Applied Psychophysiology and Biofeedback* Volume: 28, Issue: 3, September 2003, pp. 217 - 231
- [4] Krepki, Roman; Blankertz, Benjamin; Curio, Gabriel; Müller, Klaus-Robert, The Berlin Brain-Computer Interface (BBCI) – towards a new communication channel for online control in gaming applications. *Multimedia Tools and Applications* Volume: 33, Issue: 1, April 2007, pp. 73 – 90
- [5] HUNG C., LEE P., WU Y., CHEN L. YEH T., HSIEH J., Recognition of Motor Imagery Electroencephalography Using Independent Component Analysis and Machine Classifiers. *Annals of Biomedical Engineering*, Vol. 33, No. 8, 2005, pp. 1053–1070



ALEKSANDRA KAWAŁA, DARIUSZ ZMARZŁY, SZCZEPAN PASZKIEL  
OPOLE UNIVERSITY OF TECHNOLOGY, POLAND

### Active electrode for Brain – Computer Interfaces

**Key words:** evoked potentials, ERP, brain-computer interface, P300, electroencephalography.

#### Introduction

The following paper treats about the idea of devices' control using brain's signals. The scientists all over the world have always tried to provide a non-muscular channel for transmitting messages to the external device, such as Brain-Computer Interface (BCI), which has currently the common usage in military, science and medicine [1, 2, 10]. The idea of researching the following interface came from medicine, where is the highest necessity to develop a non-muscular interface by the advent of low - cost, popular personal computers for recognition of needs and potentials of people with neuromuscular problems [2].

Currently it is possible to discern two main sorts of Brain-Computer Interface: invasive and non-invasive [3, 4]. The invasive can partly restore the motor functions in paralyzed person. The non-invasive is mainly used as an interface between human (brain) and personal computer [1]. Present BCI determine the intent of the user from various electro physiological signals such slow cortical potential, P300 potentials - subject of authors' researches, mu or beta rhythms [2, 5].

Studies of Brain-Computer Interfaces' systems have involved recording of repeated electroencephalographic (EEG) signal using, in authors' case, active electrodes. This method have many advantages, because it is relatively convenient, inexpensive and harmless, and what is more – there is no need of surgeon intervention, what can cause many dangerous complications [6].

To classify EEG signal it is difficult, because recorded electroencephalographic signals usually change over time due to biological and technical causes. This leads to the necessity of implementation of adaptive learning algorithms. To the biological factors, which may cause artifacts or other problems in analyzing the researched, recorded signal are: electrodes' impedances, noise of amplifier, progression of any disease, subject's attention or just environmental noise. Those factors make it hard to classify different signals [6, 7, 9, 10, 10].

In paper the project of active electrode used in P300 based on EEG BCI was proposed. This may be an alternative for currently existing based on analyze of mu or beta rhythms.

#### Brain – Computer Interfaces

There have been already researched many sorts of Brain – Computer Interfaces including invasive which incorporates implanted electrodes and non-invasive that uses surface electrodes.

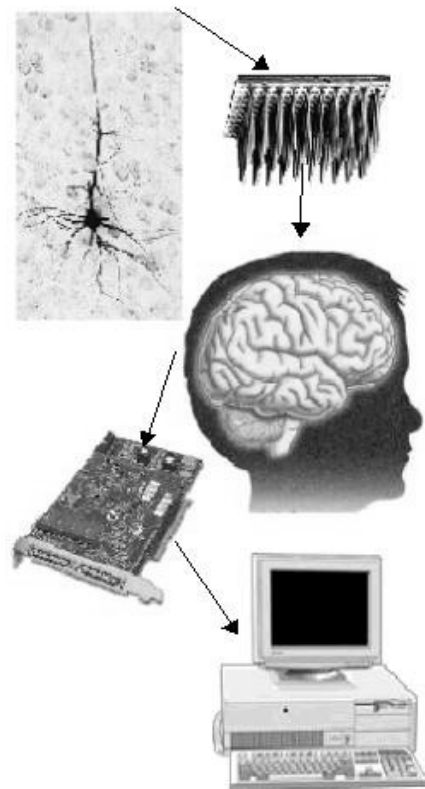


Fig. 1. Design of invasive Brain-Computer Interface [1,8].

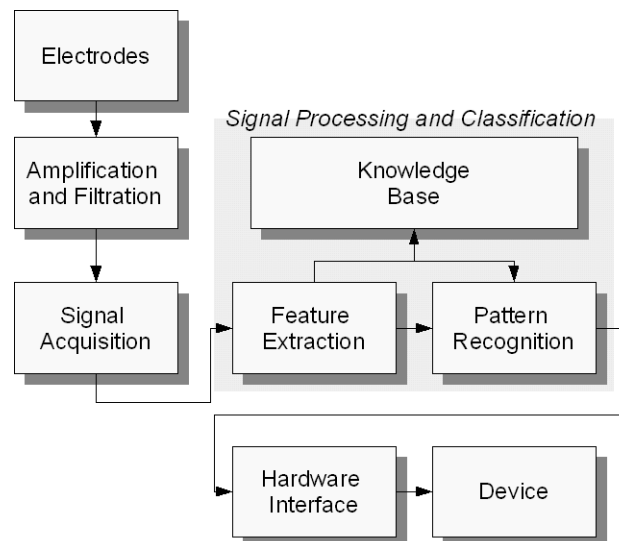


Fig. 2. Information flow diagram in BCI systems [2].

The difference between methods is that there is no necessity for surgeon intervention in non-invasive method and additionally it is cheaper and safer. The problems are in upcoming in signal artifacts. The authors of the following paper research the non-invasive, based on electrencephalographic signal and analyze the P300 wave Brain-Computer Interface.

Figure 1 presents a general design of an invasive BCI. Neurons (especially piramidal neurons in cortical parts of brain) involve implant. While the patient thinks, his neurons generate signal, which is taken by electrode matrix. The voltage signal proportional to neural activity is sent to data aquisition board connected with computer. A proper software is responsible for visualisation and controlling e.g. mechanical devices [1, 8, 10].

The diagram of flow of the information in a system is presented in figure 2. The measurement object (a brain) generates EEG signal which is amplified, filtered and acquired. Then it is transmitted to computer and processed by special software. The representative parameters are extracted from the signal and the charateristic features are remembered in a knowledge base. Furthermore parameters are basis for the classification algorithm. The result of identification is used for controlling of an application or an external device.

### P300

P300 wave is an event related potential, which is possible to observe in scalp-recorded EEG during external stimulus. The P300 wave is an excellent signal for controlling a Brain – Computer Interface [9]. The most succesfull idea for an external simulation is an experiment called „Oddball Paradigm”. This experiment relies on „expecting” something unusuall by researched patient. After about 300 ms it is possible to observe in the EEG over parietal cortex a positive peak. [2].

Proper classification of P300 the identification of character is easier and the controll of external mechanical device possible [2, 9].

The first one who used evoked potentials in Brain – Computer Interfaces was Sutter, who placed four passive electrodes over visual cortex, what leded to communicating as 10 till 12 words per minute.

The speed of communication in Brain – Computer Interfaces was always a big disadvantage. The communication is currently too slow. The world record was made by scientists from Graz and it is 8 signs per second [2].

### P300 EVOKED POTENTIAL

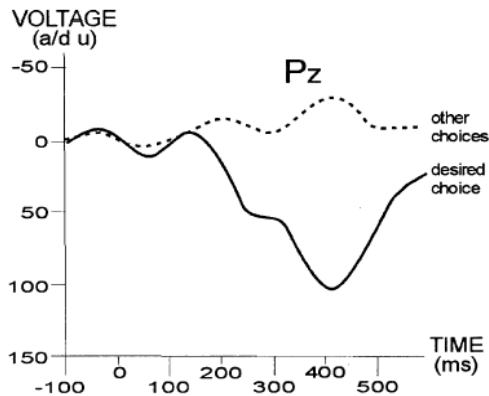


Fig.

3. P300 BCI. A matrix of possible choices is presented on a screen and scalp EEG is recorded over the centroparietal area while these choices flash in succession. Only the choice desired by the user evokes a large P300 potential [2].

The effect of P300's apparition relies on user's intents. Scientists who made online experiments and offline simualtions describe the relationship between the number of trials per selection and BCI accuracy. This leads to proposal that the possible speed of communication is about one word (ca. 5-6 letters) per minute [2].

Minimal trial length is two seconds with only one second for decision. This is a physiological limit used for control [11].

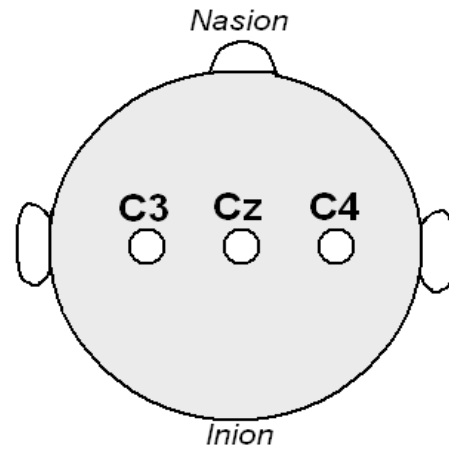


Fig. 4. The configuration „10-20” with marked C3 and C4 points.

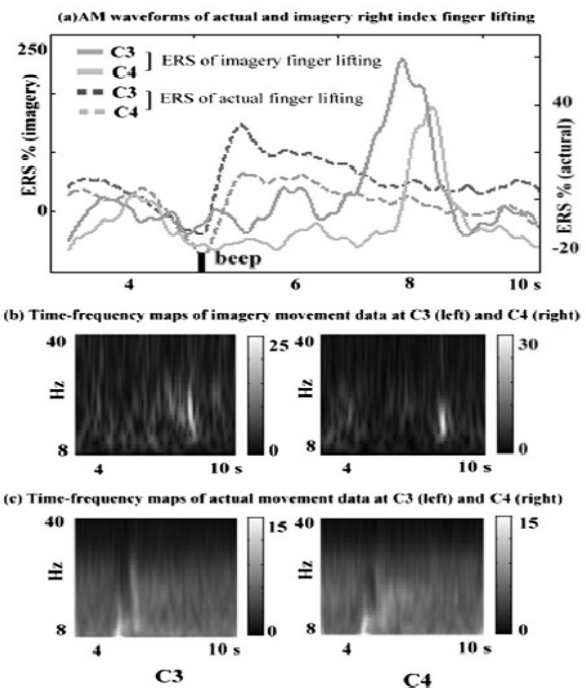
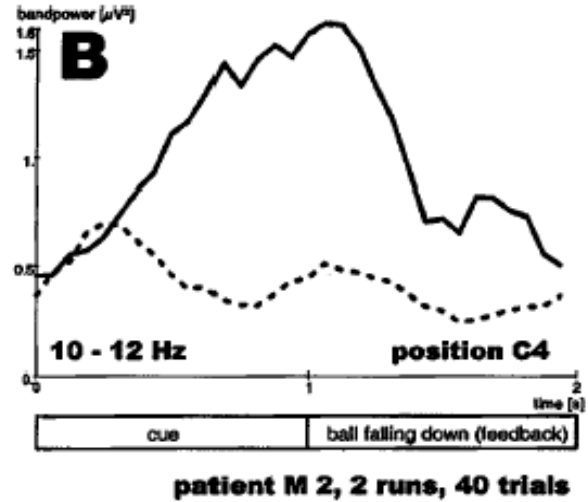
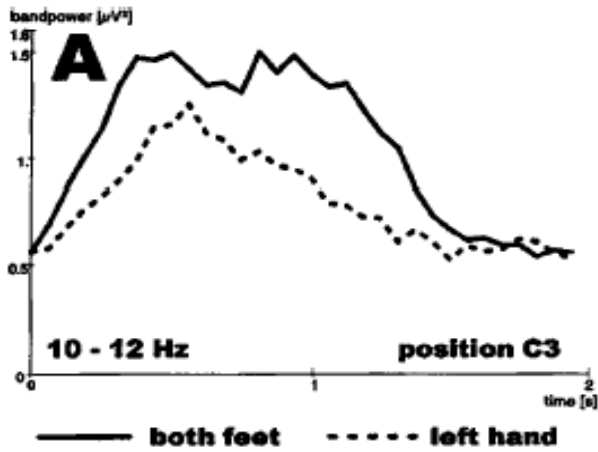


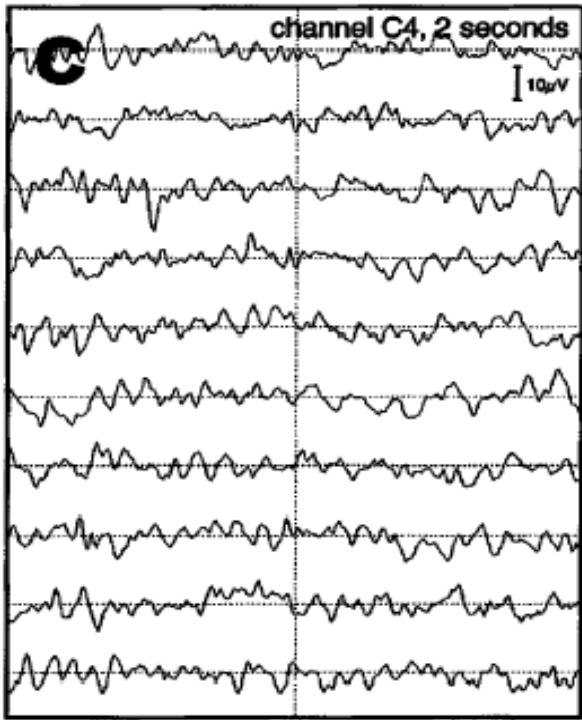
Fig. 5 (a) Imagery and actual finger movements. (b) Time-frequency maps of imagery movement. (c) Time-frequency maps of real movement [12].

It is possible to observe P3a and P3b when the active electrodes are in points C3 and C4 (Fig. 4).

Figure 5 presents grafs of imaginery and real finger lifting. Signal comes from C3 and C4 electrodes. Under the graph are shown time-frequency maps of imaginery and real finger movements. Figures 6 and 7 present, that rebounds for imaginery movements have much longer latency than actual movements [11, 12].



**left hand motor imagery**



**both feet motor imagery**

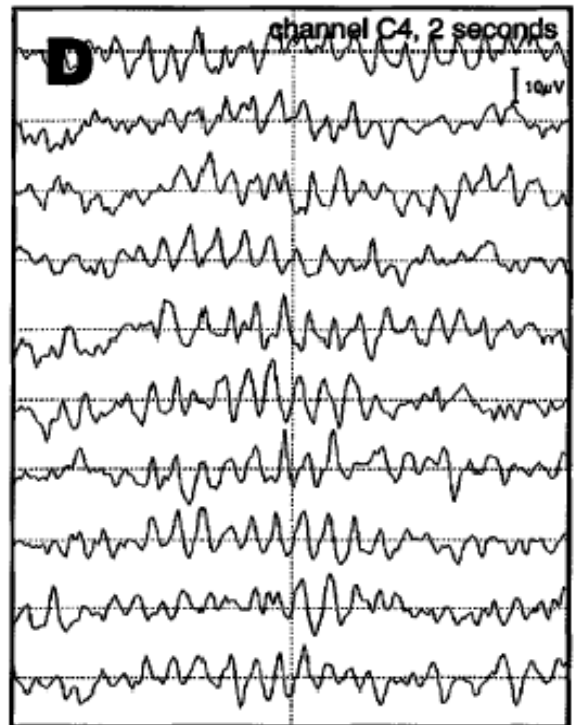


Fig. 6. Example trials recorded from electrode position C4 for a left-hand motor imagery [11].

Fig.7. Active electrodes and control module on patient's head [own work].

**BCI system with active electrodes**

The authors designed and constructed a facility for measuring, acquiring and processing of EEG signal for purpose of Brain Interface Communication. The system consists of two active electrodes and main microcontroller board connected wirelessly with Personal Computer.

The electrodes are in surface configuration and are connected with skin in C3 and C4 locations. Figures 8 and 9 present patient (female) with assembled BCI and a picture of system with holder wire. The 13 silver wires of diameter of 0.5 mm and length of 20 cm was used as an electrode in both cases. It has a form of comb and does not require any electroconductive gels. Besides the comb geometry facilitates measurements for patients with longer hair and reduces artifacts occurred because of their length. Figure 9 presents picture of active electrode.

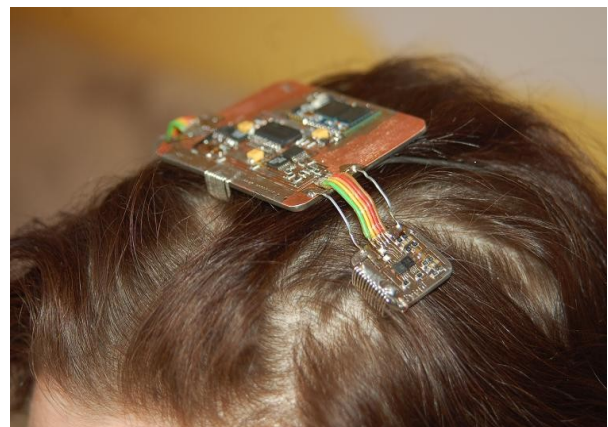


Fig. 8. Picture of BCI system [own work].

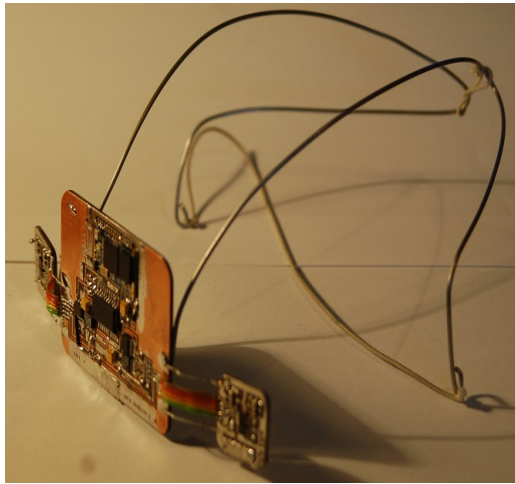


Fig. 9. EEG with comfortable holder [own work].

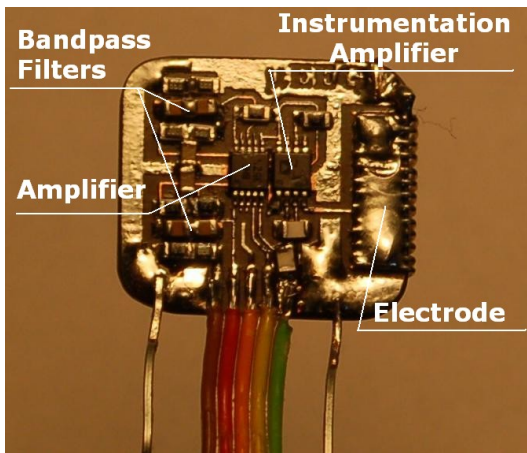


Fig. 10. Picture of active electrode [own work].

This active electrode (Fig. 10.) contains bandpass filters and two amplifiers. Electrode has contact with patient's skin via silver needles. Control module was presented in the figure 11. Schematic of whole system is presented in figure 12.

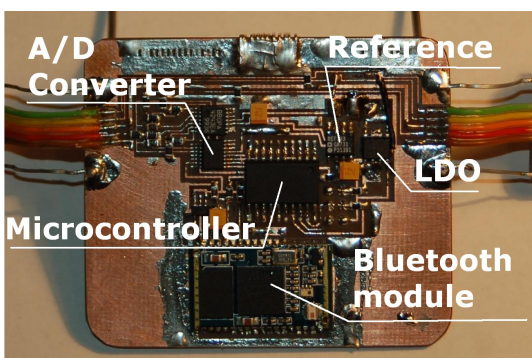


Fig. 11. Picture of control module [own work].

The analog part of the system consists of instrumentation amplifier (AD8221) and filters together followed with amplifiers (OPA2234). Two channel 24-bit ADC (ADS1253) converts signal to digital form which is transferred to microcontroller (ATTINY2313) (Fig. 12). The communication with personal computer goes via Bluetooth interface. Currently are lead researches on reducing an influence of artifacts.

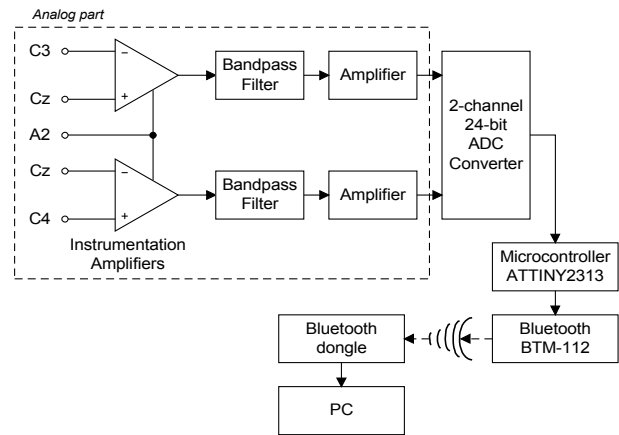


Fig. 12. Schematic of measurement system [own work].

## REFERENCES

1. Kawala A., Khoma V., Zmarzły D., Sovyn Y.: *Przegląd metod sterowania maszynami przy użyciu sygnałów myślowych*. Przegląd Elektrotechniczny nr 3/2008, ISSN 0033-2097, Warszawa 2008.
2. Wolpaw J. R., Birbaumer N., McFarland D. J., Pfurtscheller G., Vaughan T. M.: *Brain-computer interfaces for communication and control*. Clinical Neurophysiology Vol. 113, Issue: 6, June 2002.
3. Schwartz A. B., Taylor D. M., Tillery S. I. H.: *Extraction algorithms for cortical control of arm prosthetics*. Curr Opin Neurobiol, Vol. 11, 2001.
4. Lal T. N., Hinterberger T., Widman G., Schroeder M., Hill J., Rosentiel W., Elger C. E., Schoelkopf B., Birbaumer N.: *Methods Towards Invasive Human Brain Computer Interfaces*. Workshop on Verification, Validation and Testing of Learning Systems, NIPS-2004, British Columbia, 2004.
5. Krepki R., Blankertz B., Curio G., Mueller K.-R.: *The Berlin Brain-Computer Interface (BBCI) – towards a new communication channel for online control in gaming applications*. Multimedia Tools and Applications Vol. 33, Issue 1, April 2007.
6. Sun S., Zhang C.: *Adaptive feature extraction for EEG signal classification*. Medical & Biological Engineering & Computing Vol. 44, Issue 10, October 2006.
7. Vaughan TM (2003) Guest editorial brain-computer interface technology: a review of the second international meeting. IEEE Trans Neural Syst Rehabil 11:94–109.
8. Martini R.: *Mind Control*. Wired Magazine Vol. 13 no. 3, 2005.
9. Brendan A. Z., McFarland D. J., Schalk G., Zheng S. D., Jackson M. M.: *Towards an independent brain-computer interface using steady state visual evoked potentials*. Clinical Neurophysiology Vol. 119, Issue 2, February 2008.
10. Krusienski D. J., Sellers E. W., McFarland D. J., Vaughan T. M., Wolpaw J. R.: *Towards enhanced P300 speller performance*. Journal of Neuroscience Methods Vol. 167, Issue 1, January 2008.
11. Krausz G., Schreer R., Korisek G., Pfurtscheller G.: *Critical Decision-Speed and Information Transfer in the "Graz Brain-Computer Interface"*. Applied Psychophysiology and Biofeedback Vol. 28, No. 3, 2003.



12. Hung C., Lee P., Wu Y., Chen L., Yeh T., Hsieh J.: *Recognition of Motor Imagery Electroencephalography Using Independent Component Analysis and Machine Classifiers*. Annals of Biomedical Engineering, Vol. 33, No. 8, 2005.

#### **SHORT ABSTRACT**

The paper presents shortly the idea of Brain – Computer Interfaces based on EEG and event related potential P3. The idea and project of dual channel EEG with two active electrodes was also presented in article.

Mgr inż. Aleksandra Dagmara Kawala  
Dr hab. inż. Dariusz Zmarzły  
Mgr inż. Szczepan Paszkiel  
Politechnika Opolska  
Wydział Elektrotechniki, Automatyki i Informatyki  
Instytut Elektroenergetyki,  
ul. Prószkowska 76 Bud. 2  
45-758 Opole

E-mail: [kawala84@doktorant.po.opole.pl](mailto:kawala84@doktorant.po.opole.pl)  
[dariusz@zmarzly.com](mailto:dariusz@zmarzly.com)  
[szczepu1@interia.pl](mailto:szczepu1@interia.pl)

**Aleksandra Dagmara Kawala**  
Wydział Elektrotechniki, Automatyki i Informatyki  
Instytut Elektroenergetyki

## TIME-FREQUENCY ANALYSIS OF EEG SIGNALS

**Abstract:** In the following paper time-frequency analysis of electroencephalographic signals, recorded from active electrodes placed on scalp, was presented. The time-frequency analysis represents signal in both the time and frequency domains. It is used in order to extract information from the signal or to separate the analysed signal from noise or other artifacts.

In order to analyze a signal whose component frequencies vary in time, one first obtains a time-frequency distribution of the signal, which represents the signal in both the time and frequency domains simultaneously. The techniques of time-frequency analysis may then be applied to the signal in order to extract information from the signal, to separate the signal from noise or interfering signals, etc [2]. The researched signal comes from a freeware, open data for matlab. The experiment, from which the eeg signal comes, depended on visual stimulation of an examined person by lighting two squares (on the left and right side) in the screen. Each square was marked by a different colour – red [1<sup>st</sup> event] and blue [2<sup>nd</sup> event].

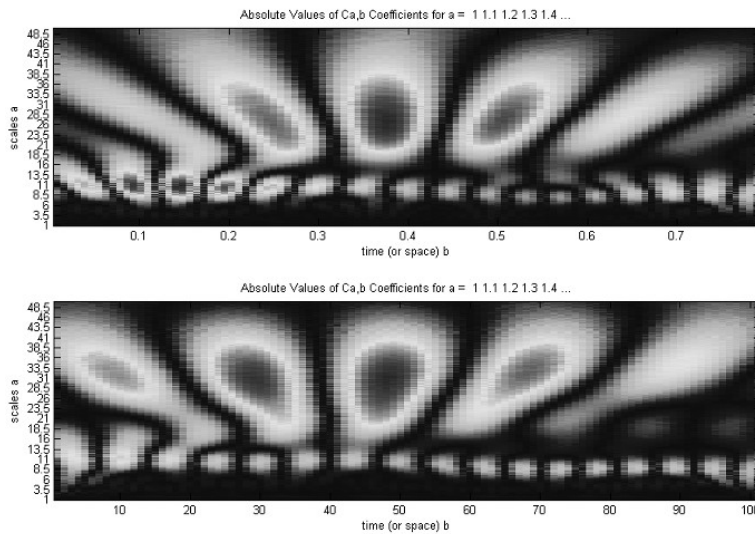


Fig. 1. Time-frequency analysis in C3 and C4 for the 1<sup>st</sup> event [1, praca własna].

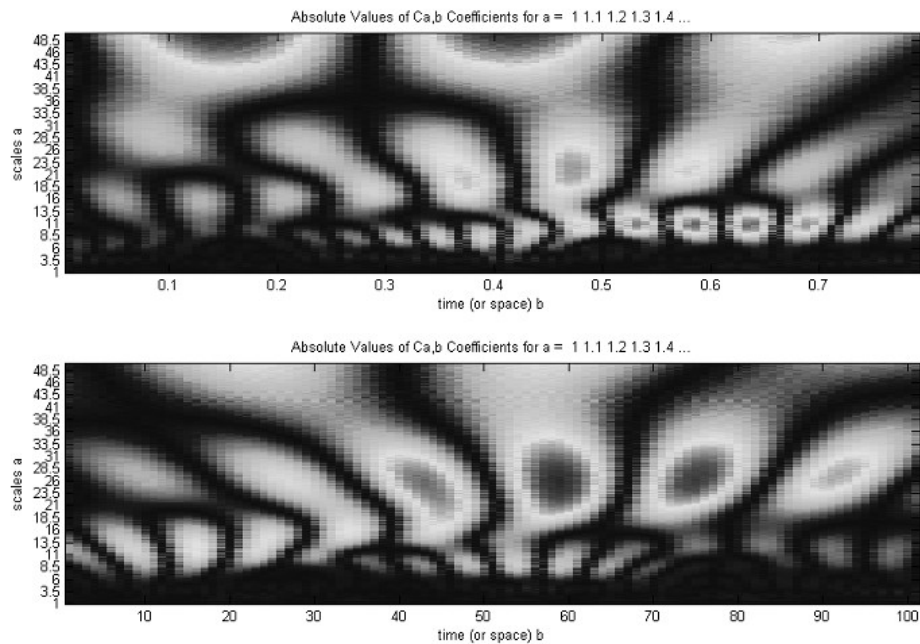


Fig. 2. Time-frequency analysis in C3 and C4 for the 2<sup>nd</sup> event [1, praca własna].

The examined person had to push a button in case of lighting appropriate square. The event repeated 154 times. The signal generated during this research was analysed by author of hereof paper, who was concentrated on analysis in channels C3 and C4 [1, 3]. Fig. 1. and Fig. 2. present EEG signal recorded from channels C3 and C4 in a random moment for the both events. The time-frequency analysis shows, that for the 2<sup>nd</sup> event occurred delay. The delay proves, that it is hard to classify the event. In practise after a few milliseconds it is possible to classify kind of the event. Author would like to improve the methods of signal classification in her scientific work.

## BIBLIOGRAPHY

- [1] <http://sccn.ucsd.edu/>
- [2] Zieliński T. P., Cyfrowe przetwarzanie sygnałów. Od teorii do zastosowań., Warszawa 2007
- [3] Osowski S., Cichocki A., Siwek K., MATLAB w zastosowaniu do obliczeń obwodowych i przetwarzania sygnałów, Warszawa 2006

Projekt współfinansowany ze środków Europejskiego Funduszu Społecznego

**ALEKSANDRA KAWALA-JANIK**

Faculty of Electrical Engineering Automatic Control and Informatics  
Institute of Electric Power Engineering

## **THE USE OF DOUBLE FILTRATION IN ANALYSIS OF EEG SIGNALS**

**Abstract:** In the following paper was presented double filtration of the EEG signals. The researched and analysed signals come from measurements conducted by the author of the hereof paper. The author will also hereby describe shortly one of the led experiments conducted inter alia at the Silesian University of Technology.

The analysis of EEG signals is very difficult due to the complex character of these signals [1]. One of the biggest problem in the analysis is lack of predictability of the consecutive values. Another serious problem is the presence of various kinds artifacts and disturbances [2, 3]. The signals were measured from the scalp in accordance with the 10-20 standard [3]. The electrodes were placed in positions C3 and C4, what was enough for conducting the experiments, and enabled to record the signal from the both cerebral hemispheres. There were conducted six series of experiments. Researched were two objects: a female, aged 29, right-handed – hereinafter called object A, and a male, aged 22 – also right-handed – hereinafter called object B. The figure 1 presents object B during first series of experiment.



*Fig. 1. Object B during measurements.*

The experiments were led as well in Silesian University of Technology as in Opole University of Technology. The experiments consisted in moving right or left hand when on the screen of computer appeared blue (right hand) or red (left hand) square. The square appeared randomly or regularly (in every 10 seconds). In the figure 2 are presented raw and double filtered signals registered in points C3 and C4. In this case is shown – as an example - the signal from experiment with regular appearance of squares. In the fig. 3 is shown power spectral density of the measured and filtered signals. There was designed a filter that filters all frequencies except the frequency of the mu waves [4, 5].

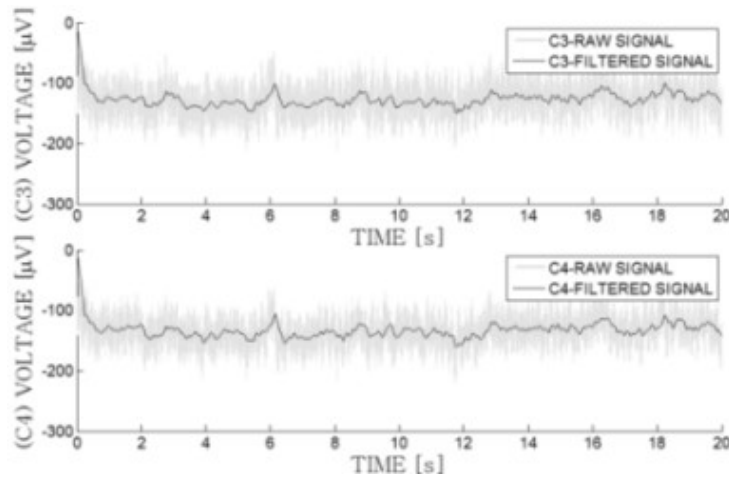


Fig. 2. Raw and double filtered signals recorded in points C3 and C4.

The double filtration used in offline analysis is the best solution due to no latency [4].

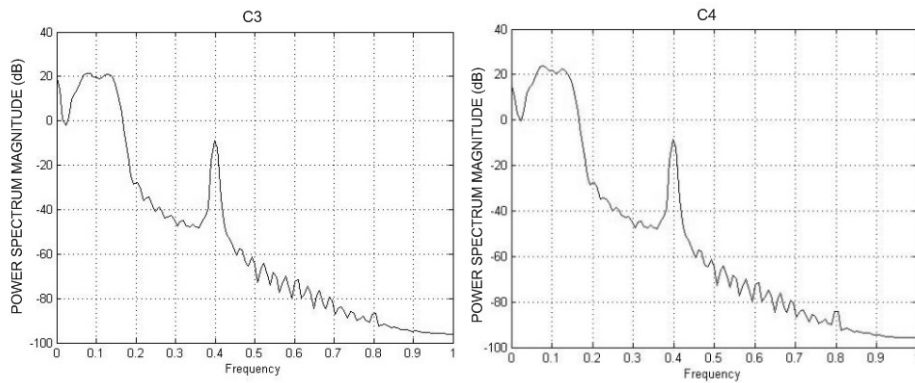


Fig. 3. PSD of measured and filtered signals.

## REFERENCES

- [1] Augustyniak P., Electrodiagnostic signals processing. Kraków 2003 (in Polish)
- [2] Stopczyk M., Medical electrodiagnostic. PZWL. Warszawa 1984 (in Polish)
- [3] Augustyniak P., Grabska-Chrząstowska J., Izworski A., Custom methods of biological signal processing. Ogólnopolskie Seminarium - Perspektywy rozwoju fizyki medycznej w Polsce. Ustroń 1996 (in Polish)
- [4] Lewandowski M., Selected methods of signals' band-pass filtration – PhD dissertation, under supervision of prof. Janusz Walczak. Politechnika Śląska. Gliwice 2009 (in Polish)
- [5] Zieliński T.P., Digital signal processing. From theory to implementation. WKiŁ 2006 (in Polish)



ALEKSANDRA DAGMARA KAWALA-JANIK, MARIUSZ PELC, RICHARD ANTHONY, JAMES  
HAWTHORNE, JIXIN MA

THE UNIVERSITY OF GREENWICH, UNITED KINGDOM

## HUMAN-COMPUTER INTERFACE BASED ON NOVEL FILTERING ALGORITHM AND THE IMPLEMENTATION OF THE EMOTIV EPOC HEADSET

**Key words:** HCI, BCI, signal processing, filtration, bio-signals, matlab

### Introduction

This paper presents in short a novel technique for using EEG signals for control of computer interfaces. Nowadays there is a constantly increasing interest in improving control methods not only for people with minor or major motor disabilities, but also for other -- non-disabled users. The use of EEG signals - what could be described as 'using thoughts' - has become more and more popular within the last few years as a method for communication between brains and computers. Although there is a numerous amount of similar to mine Brain-Computer Interfaces (BCI) I presented the novel, quick method for pattern recognition and its use to control an external device. Described and implemented algorithm is based on the two main analysis components -- analysis in the time-domain and analysis in the frequency-domain. It is also important to notice that only signals with limited information have been processed and that there is no 'full' signal processing.

### 1. CONDUCTED EXPERIMENT

The research has been conducted on five anonymous subjects. I began with the process of learning in order to establish, whether the signals obtained while doing one task are similar for various subjects. The subject had to imagine movement of either left or right hand depending on command appearing on the computer monitor. The electrodes were placed in the positions 'F3' and 'F4', according to the 10-20 system -- shown in the Figure 1 [1, 2]. The experiment was conducted in two environmental conditions -- the first one was in a quiet, close to ideal, environment, the second part was conducted in noisy room. The subjects were distracted by sound, what affected the quality of signal. The authors have taken into consideration the aspect of project usability not only in laboratory, but also in real-life environment. As it was mentioned above -- two electrodes ('F3' and 'F4') were used. This choice was caused by the location of the brain activity during imaginary movement [3, 4, 5]. While moving a limb or contracting a single muscle large influence on brain activity in cortex is being done. The preparation or imagination of the movement can also result in changing sensory-motor rhythms, which are categorised according to the main frequency bands [6]. The equipment used for the research purposes is - Emotiv

EPOC, which consists of 14 electrodes placed on the scalp and CMS/DLR reference-electrodes. The sampling rate is 120 [Hz] and the bandwidth is between 0.2 and 45 [Hz], what includes my desired frequency between 8 and 10 [Hz] [1, 7].

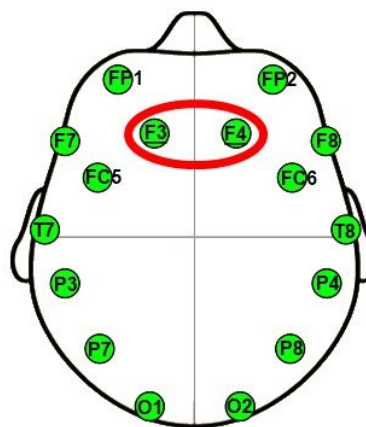


Fig.1. One-wire line [1, 2]

### 2. SIGNAL PROCESSING METHODOLOGY

In the Equation (1) is shown the mathematical interpretation of the chosen solution. There are two components to analyse. The weighted difference between the pattern and the signal has been set up for both domains - the time-domain and the frequency-domain. In case the signal is very noisy, then - as a result - its time-domain representation is not very useful for the research purposes. In this case the 'alpha'-coefficient should be set to the value '1', so that only the frequency-domain components would be taken into account. Typically -- as the best solution -- the value of the 'alpha'-coefficient should be set to 0.5, what means that the both components are equally important. The novelty of this solution is the threshold application with additional options enabling the customisation of the solution, according to the research needs or requirements. The normalised values are either '0' or '1'. It is also important to mention, that there is no 'full'-signal processing, as the analysed signal possesses only limited information. The application used for the research purposes compares the pattern signal with a signal obtained from a subject. The work of the script is based on the set value of the threshold function, the closer to the 0 it is the stricter are the criteria.

The algorithm of the application is also based on the below equation:

$$\varepsilon = \frac{(1 - \alpha)}{N} \sum_{i=1}^N (\tilde{s}_i(t) - \tilde{p}_i(t))^2 + \frac{\alpha}{M} \sum_{j=1}^M (\tilde{S}_i(\omega) - \tilde{P}_j(\omega))^2 \quad (1)$$

In the Figure 2 is presented plot of signals recorded from the electrodes placed on 'F3' and 'F4'. This is signal used as a pattern.

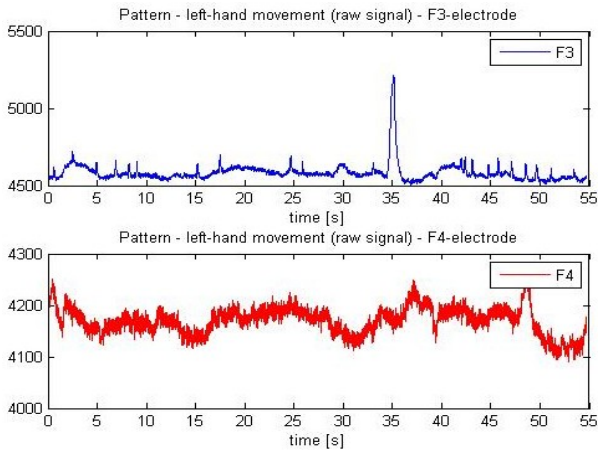


Fig.2. Raw signals - pattern [own work]

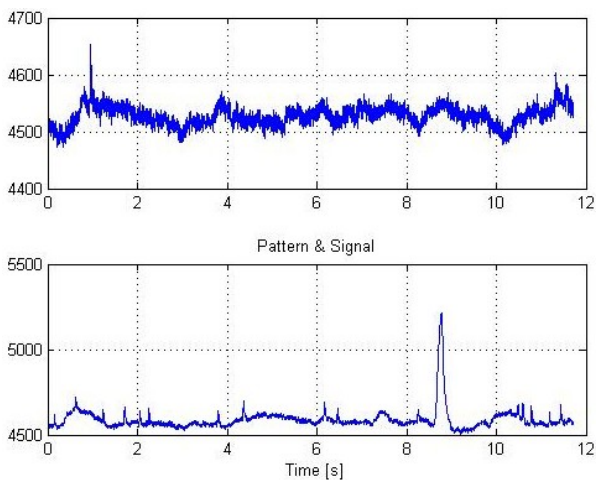


Fig.3. 'F3'-electrode, pattern (above) and subject 1 (below) – raw signal – left hand movement [own work]

```
>> md1_f3=mdl(3,:);
>> [res]=pattern_rec5(pm1_f3,mdl_f3,512,0.5,0.3)
<----- 01 ----->
<----- Scaling in time domain ----->
<----- 02 ----->
<----- Plot single-sided amplitude spectrum ----->
<----- 03 ----->
<----- Scaling in frequency domain ----->
<----- 04 ----->
<----- Applying summation criterion ----->
<----- 05 ----->
<----- Comparison result ----->
...the signals match...
res =
0
```

Fig.4. Pattern recognition process - 'screen-shot' [own work]

In the Figure 3 are shown both pattern and signal obtained from the first subject. The signals were recorded during the same task, both from the electrode placed in the 'F3' position. In the Figure 4 is shown the process of pattern recognition based on the Equation (1) for the signals presented in the Figure 3. The chosen criteria was '0.3'. The signals matched.

## 5. REFERENCES

1. <http://www.emotiv.com>
2. Tong S., Thakor N. V.: *Quantitative EEG Analysis Methods and Clinical Applications*. Artech House, 2009.
3. Kandel E. R., Schwartz J. H., Jessell T. M.: *Principles of Neural Science*. 3<sup>rd</sup> Edition, Prentice-Hall International Inc., 1991.
4. Enoka R. M.: *Neuromechanics of Human Movement*. 4<sup>th</sup> Edition, Human Kinetics, 2008.
5. Latash M.: *Neurophysiological Basis of Movement*. Human Kinetics, 1998.
6. Graimann B., Allison B., Pfurtscheller G.: *Brain-Computer Interfaces. Revolutionizing Human-Computer Interaction*. Springer-Verlag, 2010.
7. [http://emotiv.wikia.com/wiki/Emotiv\\_EPOC](http://emotiv.wikia.com/wiki/Emotiv_EPOC)

## 6. SHORT ABSTRACT

A user interface is a very important part in any aspect of human-computer interface (HCI), so its design has to be as intuitive and all-purpose as possible. User interfaces have recently become very complex, but this increased complexity does not always go in hand with increased functionality. When it comes to using various bio-signals as a means of communication between for example handicapped users and computer systems, the current market solutions are not satisfactory. The authors of this paper have developed a proposal for a novel bio-signal controlled interface, which will be both intuitive and user-friendly for prospective both healthy and physically handicapped users. The interface is based on a new algorithm that uses summary integration as a tool for bio-signal processing. This signal processing method is both faster and more flexible, and enables the use of multiple types of signals. The difference between the proposed system and existing interfaces is, as was mentioned above, its versatility for various bio-signals. In this paper, the authors have shown the possible application of the Emotiv EPOC headset as an inexpensive, easily available tool for HCI. Thorough research has been conducted by the authors of this paper in order to present a better alternative to existing methods.

Aleksandra Kawala-Janik, M.Sc.  
 Mariusz Pelc, Ph.D.  
 Richard Anthony, Ph.D.  
 James Hawthorne, B.Sc. (Hons)  
 Jixin Ma, Ph.D.  
 University of Greenwich – Greenwich Campus  
 School of Computing and Mathematical Sciences  
 Park Row  
 SE10 9LS London  
 United Kingdom

E-mail: a.kawala-janik@greenwich.ac.uk  
 m.pelc@greenwich.ac.uk  
 r.j.anthony@greenwich.ac.uk  
 j.hawthorne@greenwich.ac.uk  
 j.ma@greenwich.ac.uk

# Appendix C

## Applications Codes

### C.1 Script for the Signal Processing Purposes – full code

```
function [res]=pattern_rec5(pattern,Rsignal,Fs,a,treshold)
%For the pattern_rec function:
% IN:
%   pattern - pattern of a signal
%   signal  - the signal registered
%   Fs      - sampling frequency
%   treshold - the match treshold 0..1
% OUT:
%   res     - 0 when match, 1 otherwise
shift = 1;
step = 500;
while (true)

close all
LP=length(pattern);           % Length of pattern
LS=length(Rsignal);
if (LP <= LS)
    L=LP;
else
```



## C.1 Script for the Signal Processing Purposes – full code

---

```
L=LS;
end

signal = Rsignal(shift:LP+shift);

T = 1/Fs;           % Sample time; FS - sampling freq
t = (0:L-1)*T;     % Time vector
% Sum of a 50 Hz sinusoid and a 120 Hz sinusoid

subplot(211)
plot(t(1:L),signal(1:L))
grid
subplot(212)
plot(t(1:L),pattern(1:L))
grid
title('Pattern & Signal')
xlabel('Time [s]')

disp('<----- 01 ----->')
disp('<----- Scaling in time domain ----->')
max_SIG_T=max(abs(signal));
max_PAT_T=max(abs(pattern));
disp('<----->')

figure

ratio_SIG_T = 1.0/max_SIG_T;
ratio_PAT_T = 1.0/max_PAT_T;

subplot(211)
plot(t(1:L),signal(1:L)*ratio_SIG_T)
grid
subplot(212)
plot(t(1:L),pattern(1:L)*ratio_PAT_T)
```

## C.1 Script for the Signal Processing Purposes – full code

---

```
grid
title('Pattern & Signal - Scaled')
xlabel('Time [s]')

NFFT = 2^nextpow2(L); % Next power of 2 from length of y
Y_SIG = fft(signal,NFFT)/L;
f_SIG = Fs/2*linspace(0,1,NFFT/2+1);

Y_PAT = fft(pattern,NFFT)/L;
f_PAT = Fs/2*linspace(0,1,NFFT/2+1);

disp('<----- 02 ----->')
disp('<----- Plot single-sided amplitude spectrum ----->')
disp('<----->')

figure
subplot(211)
plot(f_SIG,2*abs(Y_SIG(1:NFFT/2+1)))
grid
subplot(212)
plot(f_PAT,2*abs(Y_PAT(1:NFFT/2+1)))
grid
title('Single-Sided Amplitude Spectrum of Signal and Pattern')
xlabel('Frequency (Hz)')
ylabel('|Y(f)|')

disp('<----- 03 ----->')
disp('<----- Scaling in frequency domain ----->')
max_SIG_F=max(abs(Y_SIG));
max_PAT_F=max(abs(Y_PAT));
disp('<----->')

figure
```

## C.1 Script for the Signal Processing Purposes – full code

---

```
ratio_SIG_F = 0.5/max_SIG_F;
ratio_PAT_F = 0.5/max_PAT_F;

signal=signal*ratio_SIG_T;
pattern=pattern*ratio_PAT_T;

Y_SIG=Y_SIG*ratio_SIG_F;
Y_PAT=Y_PAT*ratio_PAT_F;

subplot(211)
plot(f_SIG,2*abs(Y_SIG(1:NFFT/2+1)))
grid
subplot(212)
plot(f_PAT,2*abs(Y_PAT(1:NFFT/2+1)))
grid
title('Single-Sided Amplitude Spectrum of Signal and Pattern - Scaled')
xlabel('Frequency (Hz)')
ylabel('|Y(f)|')

f_STEP=abs(f_PAT(1)-f_PAT(2)); % step in frequency domain

disp('<----- 04 ----->')
disp('<----- Applying integral criterion ----->')
disp('<----->')

INT_TIME_ERR=0;
for i=1:L-1
    INT_TIME_ERR=INT_TIME_ERR+0.05*T*((pattern(i)-signal(i))^2+
    (pattern(i+1)-signal(i+1))^2);
end

YL=size(Y_SIG);
YL=YL(1);
INT_FREQ_ERR=0;
```

```
for i=1:YL-1
    INT_FREQ_ERR=INT_FREQ_ERR+0.05*f_STEP*((abs(Y_PAT(i))-
    abs(Y_SIG(i)))^2+(abs(Y_PAT(i+1))-abs(Y_SIG(i+1)))^2);
end

disp('<----- 05 ----->')
disp('<----- Comparison result ----->')
disp('<----->')
epsilon=(a*INT_TIME_ERR+(1-a)*INT_FREQ_ERR)

if (epsilon < treshold)
    disp('...the signals match...')
    res=1;
else
    disp('...the signals do not match...')
    res=0;
end
shift = shift+step;
if (shift+LP > LS)
    break;
end
end
```

## C.2 PC Application – C#

```
using System;
using System.Collections.Generic;
using System.ComponentModel;
using System.Data;
using System.Drawing;
using System.Text;
using System.Windows.Forms;
using System.IO;
```

```
using System.Net;
using System.Net.Sockets;
using System.Threading;
namespace Olka_Server_Application
{
    public partial class Form1 : Form
    {
        private Thread th1, th2;
        delegate void SetTextCallback(string text);
        string txt;
        bool _server_snd;
        bool _client_snd;
        String msg;
        public Form1()
        {
            InitializeComponent();
            th1 = new Thread(new ThreadStart(Client));
            th2 = new Thread(new ThreadStart(Server));
            _server_snd = false;
            _client_snd = false;
        }
        private void Server()
        {
            try
            {
                IPAddress ipAd = IPAddress.Parse(textBox1.Text);
                // use local m/c IP address,
                //and use the same in the client
                // Initializes the Listener
                TcpListener myList = new
                TcpListener(ipAd, Convert.ToInt16(textBox2.Text));
                // Start Listeneting at the specified port
                myList.Start();
                txt = "The server is running at port "
```

```
+ textBox2.Text + "...";
SetText(txt);
txt = "The local End point is  ":"
+ myList.LocalEndpoint;
SetText(txt);
txt = "Waiting for a connection.....";
SetText(txt);
Socket s = myList.AcceptSocket();
SetText("Connection accepted from "
+ s.RemoteEndPoint);
byte[] bb = new byte[100];
ASCIIEncoding asen = new ASCIIEncoding();
while (true)
{
    while (!_server_snd) ;
    bb = asen.GetBytes(Convert.ToString(msg.Length));
    s.Send(bb);
    s.Send(asen.GetBytes(msg));
    SetText("Sent: "+msg);
    _server_snd = false;
    /* clean up */
    s.Close();
    myList.Stop();
}
catch (Exception e)
{
    txt = "Error..... " + e.StackTrace;
    SetText(txt);
}
}
private void SetText(string text)
{
    // InvokeRequired required compares the thread ID of the
    // calling thread to the thread ID of the creating thread.
```

```
// If these threads are different, it returns true.
if (this.listBox1.InvokeRequired)
{
    SetTextCallback d = new SetTextCallback(SetText);
    this.Invoke(d, new object[] { text });
}
else
{
    this.listBox1.Items.Add(text);
}
}
private void Client()
{
    try
    {
        TcpClient tcpclnt = new TcpClient();
        SetText("Connecting.....");
        tcpclnt.Connect(textBox1.Text,
            Convert.ToInt16(textBox2.Text));
        // use the ipaddress as in the server program
        SetText("Connected");
        String str;
        Stream stm = tcpclnt.GetStream();
        ASCIIEncoding asen = new ASCIIEncoding();
        byte[] bb = new byte[100];
        byte[] ba;
        while (true)
        {
            while (!_client_snd) ;
            str = "Signal.mat";
            ba = asen.GetBytes(str);
            SetText("Transmitting: "+str);
            stm.Write(ba, 0, ba.Length);
            int k = stm.Read(bb, 0, 100);
```

```
        SetText("Received ["+k.ToString()+"] bytes");
        txt = "";
        for (int i = 0; i < k; i++)
            txt += Convert.ToChar(bb[i]);
        SetText("Received: "+txt);
        _client_snd = false;
        _server_snd = true;
        msg = txt;
    }
    tcpclnt.Close();
}
catch (Exception e)
{
    txt = "Error..... " + e.StackTrace;
    SetText(txt);
}
}
private void button2_Click(object sender, EventArgs e)
{
    th1.Start();
    SetText("Client ready");
}
private void button1_Click(object sender, EventArgs e)
{
    th2.Start();
    SetText("Server ready");
}
private void button3_Click(object sender, EventArgs e)
{
    th1.Abort();
    th2.Abort();
}
private void button4_Click(object sender, EventArgs e)
{
```



```
        _client_snd = true;
    }
}
}
```

## C.3 Matlab Application

```
% SERVER Write a message over the specified port
%
% Usage - server(message, output_port, number_of_retries)
function server_olka(message, output_port, number_of_retries)

import java.net.ServerSocket
import java.io.*
retry          = 0;
server_socket  = [];
output_socket  = [];
while true
    retry = retry + 1;
    try
        if ((number_of_retries > 0) && (retry > number_of_retries))
            fprintf(1, 'Too many retries\n');
            break;
        end
        fprintf(1, ['Try %d waiting for client to connect to this '...
                    'host on port : %d\n'], retry, output_port);
        % wait for 1 second for client to connect server socket
        server_socket = ServerSocket(output_port);
        server_socket.setSoTimeout(1000);
        output_socket = server_socket.accept;
        fprintf(1, 'Client connected\n');
        output_stream  = output_socket.getOutputStream;
        d_output_stream = DataOutputStream(output_stream);
        input_stream   = output_socket.getInputStream;
```

```

d_input_stream = DataInputStream(input_stream);
while (true)
% output the data over the DataOutputStream
% Convert to stream of bytes
    pause(5);
    bytes_available = input_stream.available;
    fprintf(1, 'Reading %d bytes\n', bytes_available);
    message = zeros(1, bytes_available, 'uint8');
    for i = 1:bytes_available
        message(i) = d_input_stream.readByte;
    end
    message = char(message);
    fprintf(1, 'Received filename: %s\n', message);
    %Call the filtration script here
    disp('... Filtration ...')
    %Call the pattern recognition script here
    disp('... Pattern Recognition ...')
    %Now, if for example the signal matches LeftHand patter,
    %one can notify the embedded system (via PC application)
    disp('... Signal Matches <LeftHand> Pattern ...')
    message = 'LeftHand';
    fprintf(1, 'Sending Notification [%d] bytes <%s>\n',
        length(message),message);
    d_output_stream.write(uint8(message),0,length(message));
    d_output_stream.flush;
% clean up
    server_socket.close;
    output_socket.close;
end
break;
catch
    if ~isempty(server_socket)
        server_socket.close
    end
end

```

```
        if ~isempty(output_socket)
            output_socket.close
        end
        % pause before retrying
        pause(1);
    end
end
end
```

## C.4 Embedded Application – C

```
#include <stdio.h>
#include <stdlib.h>
#include <sys/types.h>
#include <sys/socket.h>
#include <netinet/in.h>
#include <arpa/inet.h>
#include <unistd.h>
void HandleLeftHand()
{
    printf("Handling LeftHand signal...\n");
}
void HandleRightHand()
{
    printf("Handling RightHand signal...\n");
}
void HandleLeftLeg()
{
    printf("Handling LeftLeg signal...\n");
}
void HandleRightLeg()
{
    printf("Handling RightLeg signal...\n");
}
```

```
int main(int argc, char *argv[])
{
    printf("This is the client program\n");
    int sockfd;
    int len;
    struct sockaddr_in address;
    int result;
    char ch[100];
    //Create socket for client.
    sockfd = socket(AF_INET, SOCK_STREAM, 0);
    //Name the socket as agreed with server.
    address.sin_family = AF_INET;
    address.sin_addr.s_addr = inet_addr("172.16.24.3");
    address.sin_port = htons(22222);
    len = sizeof(address);
    //
    result = connect(sockfd, (struct sockaddr *)&address, len);
    if(result == 1)
    {
        perror("Error has occurred");
        exit(0);
    }
    while (1) {
        memset(&ch,0,100*sizeof(char));
        read(sockfd, &ch, sizeof(int));
        len=atoi(ch);
        read(sockfd, &ch, len);
        printf("Message from server = %s\n", ch);
        if (!strcmp(ch,"LeftHand"))
            HandleLeftHand();
        if (!strcmp(ch,"RightHand"))
            HandleRightHand();
        if (!strcmp(ch,"LeftLeg"))
            HandleLeftLeg();
    }
}
```

```
    if (!strcmp(ch,"RightLeg"))
        HandleRightLeg;
    }
close(sockfd);
return(0);
}
```

# Appendix D

## Tables with Results

Table D.1 presents the results for comparing signals generated during imaginary left-hand movement. Signals were obtained in quiet environment from the F4 electrode. The signals were raw – unprocessed.

Table D.2 presents the results for comparing signals generated during imaginary left-hand movement. Signals were obtained in noisy environment from the F4 electrode. The signals were raw – unprocessed.

Table D.3 presents the results for comparing signals generated during imaginary right-hand movement. Signals were obtained in quiet environment from the F3 electrode. The signals were raw – unprocessed.

Table D.4 presents the results for comparing signals generated during imaginary right-hand movement. Signals were obtained in noisy environment from the F3 electrode. The signals were raw – unprocessed.

Table D.5 presents the results for comparing signals generated during imaginary left-hand movement. Signals were obtained in quiet environment from the F4 electrode. The signals were filtered with the Butterworth filter.

Table D.6 presents the results for comparing signals generated during imaginary left-hand movement. Signals were obtained in noisy environment from the F4 electrode. The signals were filtered with the Butterworth filter.

Table D.7 presents the results for comparing signals generated during imaginary right-hand movement. Signals were obtained in quiet environment from the F3 electrode. The signals were filtered with the Butterworth filter.

**Table D.1:** Imaginary left-hand movement – F4-electrode – raw signals – quiet environment.

Compared Signals	Threshold Values					Epsilon
	0.1	0.2	0.3	0.4	0.5	
$S_1$ and $S_2$	match	match	match	match	match	0.0035984
$S_1$ and $S_5$	match	match	match	match	match	0.0032703
$S_1$ and $S_6$	match	match	match	match	match	0.0068499
$S_1$ and $S_9$	not match	match	match	match	match	0.15732
$S_1$ and $S_{10}$	match	match	match	match	match	0.0047916
$S_2$ and $S_5$	match	match	match	match	match	0.0026959
$S_2$ and $S_6$	match	match	match	match	match	0.0090083
$S_2$ and $S_9$	match	match	match	match	match	0.0097228
$S_2$ and $S_{10}$	match	match	match	match	match	0.0022269
$S_5$ and $S_6$	match	match	match	match	match	0.0077895
$S_5$ and $S_9$	not match	match	match	match	match	0.10618
$S_5$ and $S_{10}$	match	match	match	match	match	0.0019765
$S_6$ and $S_9$	not match	not match	not match	match	match	0.2767
$S_6$ and $S_{10}$	match	match	match	match	match	0.013981
$S_9$ and $S_{10}$	match	match	match	match	match	0.0048273

Table D.8 presents the results for comparing signals generated during imaginary right-hand movement. Signals were obtained in noisy environment from the F3 electrode. The signals were filtered with the Butterworth filter.

$S_n$  means a signal, where  $n$  is the order number of analysed signal.

**Table D.2:** Imaginary left-hand movement – F4-electrode – raw signals – noisy environment.

Compared Signals	Threshold Values					Epsilon
	0.1	0.2	0.3	0.4	0.5	
$S_3$ and $S_4$	match	match	match	match	match	0.022746
$S_3$ and $S_7$	match	match	match	match	match	0.0078587
$S_3$ and $S_8$	match	match	match	match	match	0.012013
$S_3$ and $S_{11}$	not match	not match	match	match	match	0.19126
$S_3$ and $S_{12}$	match	match	match	match	match	0.018074
$S_4$ and $S_7$	match	match	match	match	match	0.016339
$S_4$ and $S_8$	not match	match	match	match	match	0.10897
$S_4$ and $S_{11}$	match	match	match	match	match	0.058429
$S_4$ and $S_{12}$	match	match	match	match	match	0.056351
$S_7$ and $S_8$	match	match	match	match	match	0.006762
$S_7$ and $S_{11}$	not match	not match	match	match	match	0.18198
$S_7$ and $S_{12}$	match	match	match	match	match	0.017081
$S_8$ and $S_{11}$	not match	not match	not match	match	match	0.34117
$S_8$ and $S_{12}$	match	match	match	match	match	0.032591
$S_{11}$ and $S_{12}$	match	match	match	match	match	0.000026211

**Table D.3:** Imaginary right-hand movement – F3-electrode – raw signals – quiet environment.

Compared Signals	Threshold Values					Epsilon
	0.1	0.2	0.3	0.4	0.5	
$S_1$ and $S_2$	match	match	match	match	match	0.015
$S_1$ and $S_5$	not match	not match	not match	match	match	0.31217
$S_1$ and $S_6$	match	match	match	match	match	0.083
$S_1$ and $S_9$	match	match	match	match	match	0.063
$S_1$ and $S_{10}$	match	match	match	match	match	0.016
$S_2$ and $S_5$	not match	not match	not match	match	match	0.31751
$S_2$ and $S_6$	match	match	match	match	match	0.087
$S_2$ and $S_9$	match	match	match	match	match	0.073
$S_2$ and $S_{10}$	match	match	match	match	match	0.026
$S_5$ and $S_6$	match	match	match	match	match	0.007268
$S_5$ and $S_9$	match	match	match	match	match	0.0063183
$S_5$ and $S_{10}$	match	match	match	match	match	0.0067512
$S_6$ and $S_9$	not match	not match	match	match	match	0.211
$S_6$ and $S_{10}$	match	match	match	match	match	0.0791
$S_9$ and $S_{10}$	match	match	match	match	match	0.093



**Table D.4:** Imaginary right-hand movement – F3-electrode – raw signals – noisy environment.

Compared Signals	Threshold Values					Epsilon
	0.1	0.2	0.3	0.4	0.5	
$S_3$ and $S_4$	match	match	match	match	match	0.014
$S_3$ and $S_7$	match	match	match	match	match	0.024
$S_3$ and $S_8$	not match	not match	not match	not match	not match	0.52
$S_3$ and $S_{11}$	match	match	match	match	match	0.02
$S_3$ and $S_{12}$	match	match	match	match	match	0.038
$S_4$ and $S_7$	not match	not match	match	match	match	0.22
$S_4$ and $S_8$	match	match	match	match	match	0.072
$S_4$ and $S_{11}$	not match	match	match	match	match	0.129
$S_4$ and $S_{12}$	match	match	match	match	match	0.05
$S_7$ and $S_8$	match	match	match	match	match	0.073
$S_7$ and $S_{11}$	not match	match	match	match	match	0.125
$S_7$ and $S_{12}$	match	match	match	match	match	0.048
$S_8$ and $S_{11}$	match	match	match	match	match	0.044
$S_8$ and $S_{12}$	match	match	match	match	match	0.019
$S_{11}$ and $S_{12}$	match	match	match	match	match	0.027

**Table D.5:** Imaginary left-hand movement – F4-electrode – filtered signals – quiet environment.

Compared Signals	Threshold Values					Epsilon
	0.1	0.2	0.3	0.4	0.5	
$S_1$ and $S_2$	match	match	match	match	match	0.078171
$S_1$ and $S_5$	not match	match	match	match	match	0.11889
$S_1$ and $S_6$	not match	match	match	match	match	0.14485
$S_1$ and $S_9$	match	match	match	match	match	0.04345
$S_1$ and $S_{10}$	match	match	match	match	match	0.045912
$S_2$ and $S_5$	not match	match	match	match	match	0.12052
$S_2$ and $S_6$	not match	match	match	match	match	0.13016
$S_2$ and $S_9$	match	match	match	match	match	0.044863
$S_2$ and $S_{10}$	match	match	match	match	match	0.047276
$S_5$ and $S_6$	not match	not match	match	match	match	0.1836
$S_5$ and $S_9$	match	match	match	match	match	0.086746
$S_5$ and $S_{10}$	match	match	match	match	match	0.091374
$S_6$ and $S_9$	not match	match	match	match	match	0.10748
$S_6$ and $S_{10}$	not match	match	match	match	match	0.10404
$S_9$ and $S_{10}$	match	match	match	match	match	0.0036631

**Table D.6:** Imaginary left-hand movement – F4-electrode – filtered signals – noisy environment.

Compared Signals	Threshold Values					Epsilon
	0.1	0.2	0.3	0.4	0.5	
$S_3$ and $S_4$	not match	match	match	match	match	0.13023
$S_3$ and $S_7$	not match	match	match	match	match	0.14117
$S_3$ and $S_8$	not match	not match	match	match	match	0.19301
$S_3$ and $S_{11}$	match	match	match	match	match	0.070292
$S_3$ and $S_{12}$	not match	not match	not match	match	match	0.289805
$S_4$ and $S_7$	not match	match	match	match	match	0.14882
$S_4$ and $S_8$	not match	not match	match	match	match	0.17747
$S_4$ and $S_{11}$	match	match	match	match	match	0.06887
$S_4$ and $S_{12}$	match	match	match	match	match	0.068616
$S_7$ and $S_8$	not match	not match	match	match	match	0.19842
$S_7$ and $S_{11}$	match	match	match	match	match	0.087279
$S_7$ and $S_{12}$	match	match	match	match	match	0.087213
$S_8$ and $S_{11}$	not match	match	match	match	match	0.11103
$S_8$ and $S_{12}$	not match	match	match	match	match	0.11181
$S_{11}$ and $S_{12}$	match	match	match	match	match	0.00085538

**Table D.7:** Imaginary right-hand movement – F3-electrode – filtered signals – quiet environment.

Compared Signals	Threshold Values					Epsilon
	0.1	0.2	0.3	0.4	0.5	
$S_1$ and $S_2$	match	match	match	match	match	0.07388
$S_1$ and $S_5$	not match	not match	not match	not match	not match	0.47
$S_1$ and $S_6$	match	match	match	match	match	0.07373
$S_1$ and $S_9$	match	match	match	match	match	0.064099
$S_1$ and $S_{10}$	match	match	match	match	match	0.07914
$S_2$ and $S_5$	not match	not match	not match	not match	not match	0.8
$S_2$ and $S_6$	match	match	match	match	match	0.088479
$S_2$ and $S_9$	match	match	match	match	match	0.07015
$S_2$ and $S_{10}$	match	match	match	match	match	0.097925
$S_5$ and $S_6$	not match	not match	match	match	match	0.256
$S_5$ and $S_9$	not match	not match	not match	match	match	0.35
$S_5$ and $S_{10}$	not match	not match	not match	match	match	0.28
$S_6$ and $S_9$	match	match	match	match	match	0.075704
$S_6$ and $S_{10}$	match	match	match	match	match	0.093918
$S_9$ and $S_{10}$	match	match	match	match	match	0.082346

**Table D.8:** Imaginary right-hand movement – F3-electrode – filtered signals – noisy environment.

Compared Signals	Threshold Values					Epsilon
	0.1	0.2	0.3	0.4	0.5	
$S_3$ and $S_4$	not match	match	match	match	match	0.1194
$S_3$ and $S_7$	not match	match	match	match	match	0.11426
$S_3$ and $S_8$	not match	match	match	match	match	0.10292
$S_3$ and $S_{11}$	not match	match	match	match	match	0.11849
$S_3$ and $S_{12}$	not match	match	match	match	match	0.12176
$S_4$ and $S_7$	not match	match	match	match	match	0.1097
$S_4$ and $S_8$	match	match	match	match	match	0.094408
$S_4$ and $S_{11}$	not match	match	match	match	match	0.11386
$S_4$ and $S_{12}$	not match	match	match	match	match	0.11143
$S_7$ and $S_8$	match	match	match	match	match	0.076533
$S_7$ and $S_{11}$	match	match	match	match	match	0.088586
$S_7$ and $S_{12}$	not match	not match	not match	match	match	0.299246
$S_8$ and $S_{11}$	match	match	match	match	match	0.08331
$S_8$ and $S_{12}$	match	match	match	match	match	0.094676
$S_{11}$ and $S_{12}$	match	match	match	match	match	0.095702