

*Phosphodiesterase 4 Inhibitors for the Treatment of Inflammation
Associated with Respiratory Disease*

By

Nicola Cooper [B.Sc. (Hons)]

A collection of scientific publications submitted in partial fulfilment for
the degree of Doctor of Philosophy (by Publication), of The University of
Greenwich, in Pharmacology

August, 2010

**School of Science
The University of Greenwich,
Medway Campus,
Central Avenue,
Chatham Maritime,
Kent ME4 4TB, UK**



the
UNIVERSITY
of
GREENWICH

ACKNOWLEDGEMENTS

I would like to thank Dr Robert Gristwood the Research Director at both Almirall and Chiroscience who introduced me to the fascinating area of PDE4 inhibitors and put such a great deal of faith in my scientific abilities. He remains a great inspiration to me as a pharmacologist and ‘drug hunter’.

I would also like to thank Dr Robin Bannister for encouraging me to undertake this doctoral thesis and for his undying enthusiasm.

On a personal note I would like to thank my husband John for supporting me in carrying out this thesis, his back up squad of our 2 sons Joe and Ged who have made me smile when I might just have been taking myself a little too seriously and my Mum and Dad for always being there to help and support me.

My sincere thanks to Prof. Babur Z. Chowdhry and Dr John Spencer.

ABSTRACT

Phosphodiesterase 4 Inhibitors for the Treatment of Inflammation Associated with Respiratory Disease

This submission for a PhD, by publication, which is based upon a series of original research studies published between 1998 and 2002 focuses on the selection of novel phosphodiesterase 4 (PDE4) inhibitors for the treatment of inflammation associated with respiratory diseases such as asthma and chronic obstructive pulmonary disease. A number of issues, relevant at the time, have been considered including: a) *in vitro* methods predictive of *in vivo* therapeutic index of anti-inflammatory efficacy over emetic side effects, b) *in vivo* methods for confirming therapeutic index and c) early confirmation of functional activity in a human system. In addition to 10 peer-reviewed articles, a poster presented at the *American Thoracic Society* (ATS) conference in 1999 and a review article published in *Trends in Pharmacological Sciences* (publication 1) in 1997 are also included.

In the initial work (publication 2) to investigate if it was possible to correlate *in vitro* activity with *in vivo* efficacy for PDE4 inhibitors structurally diverse compounds were tested in a series of experimental systems. The compounds tested were SB 207499, LAS 31025, CDP 840, rolipram and RP 73401. The *in vitro* experiments consisted of PDE4 enzyme activity (guinea pig and human inflammatory cells) and rolipram binding activity, RBA (rat brain). The *in vivo* model used was the guinea pig skin model of eosinophil recruitment, which involves systemic ¹¹¹In-eosinophil recruitment to guinea pig skin induced by a range of inflammatory mediators [i.e. PCA, PAF and zymosan activated plasma (ZAP)]. Previous studies with PDE4 inhibitors had not examined the correlation between *in vitro* and *in vivo* activities in this way. RP73401 was the most potent PDE4 enzyme inhibitor (guinea pig macrophage) followed by SB 207499>CDP 840> rolipram>LAS 31025. Rolipram binding activity did not follow the same ranking, though RP73401 was again the most potent followed by rolipram>SB 207499>CDP 840>LAS31025. Attenuation of eosinophil recruitment was consistently observed regardless of inflammogen with the following rank order of potency: RP 73401= rolipram>LAS 31025>SB 207499>CDP 840. In this model no correlation was found between the *in vitro* activities and *in vivo* efficacy. A cell based *in vitro* assay, LPS induced TNF α release from human PBMCs was also included in this publication. All of the PDE4 inhibitors tested were efficacious in this assay with a potency order of: RP 73401>SB 207499 = rolipram = CDP 840>LAS 31025.

In publications 3-7, *in vitro* and *in vivo* data are presented on a large number of compounds from a diverse range of chemical classes. In all cases the *in vitro* focus pertains to the ratio of PDE4 enzyme activity to rolipram binding activity (PDE4:RBA) as a method of selecting compounds with an improved therapeutic index of anti-inflammatory efficacy over emetic side effects. In these publications emesis data were included together with efficacy data in order to determine if *in vitro* predictions of therapeutic index were of relevance *in vivo*. The drug classes examined were xanthines, aryl sulphonamides, quinolones, 7-methoxybenzofuran-4-

carboxamides, and 7-methoxyfuro[2,3-*c*]pyridine-4-carboxamides. The lead molecules selected in each publication had improved PDE4:RBA ratios which translated into an improved therapeutic window *in vivo*. These generated lead molecules (compound numbers from publication); corresponding PDE4:RBA ratios, skin eosinophilia efficacious dose and ferret non-emetic doses are as follows: publication 3, xanthine (3c), 4.1, 5 mg/kg, 10 mg/kg; publication 4, aryl sulphonamide (20), <0.6, 5 mg/kg, 10 mg/kg; publication 5, quinolone (7g), <0.7, 10 mg/kg, 20 mg/kg; publication 6, 7-methoxybenzofuran-4-carboxamides (3a), 0.37, 0.5 mg/kg, 10 mg/kg and publication 7, 7-methoxyfuro[2,3-*c*]pyridine-4-carboxamides (8a), 0.16, 10 mg/kg (lung eosinophilia), not evaluated in the ferret.

The objective of the method for the selection of novel PDE4 inhibitors for the treatment of inflammation associated with respiratory diseases was to nominate compounds into drug development. The molecules had to successfully exhibit all of the criteria set in the screening cascade to be considered safe and efficacious enough to be tested in clinical trials. Publication 8 and the ATS poster refer to the first development compound nominated for clinical development, D 4418. This compound demonstrated efficacy in the guinea pig lung model of airway function, eosinophil infiltration and bronchial hyperreactivity at 10 mg/kg, p.o. and did not evoke emesis in the ferret at 100 mg/kg. In a Phase I clinical trial when dosed between 5 and 200 mg, D 4418 had a good pharmacokinetic profile and only mild side effects of headache, dizziness and nausea but no vomiting. No further clinical development was carried out with this molecule.

Publications 9, 10 and 11 refer to the discovery, synthesis and pharmacology of a second development candidate, SCH 351591. This compound was more potent than D 4418 both *in vitro* and *in vivo* and had a wider therapeutic index for efficacy over side effects. SCH 351591 demonstrated efficacy in the guinea pig lung model of airway function, eosinophil infiltration and bronchial hyperreactivity at 0.3 mg/kg, p.o. and did not evoke emesis in the ferret at 5 mg/kg showing it to have a promising preclinical profile for the treatment of respiratory inflammation.

Due to the final submitted publication being dated as 2002 two sections are included at the end of this thesis to cover further work carried out on SCH 351591 and in the PDE4 area from 2002 to date.

Nicola Cooper [B.Sc. (Hons)]

CONTENTS

Title Page	<i>i</i>
Declaration	<i>ii</i>
Acknowledgements	<i>iii</i>
Abstract	<i>iv</i>
Table of Contents	<i>vi</i>
Aims of Publications	<i>ix</i>
List of Research Publications	<i>x</i>
List of Figures	<i>xii</i>
List of Tables	<i>xiv</i>
Abbreviations	<i>xvi</i>
Chapter 1	
1. Review of the Phosphodiesterase 4 Literature	1
1.1 Respiratory Disease	5
1.1.1 COPD	5
1.1.2 Asthma	6
1.2 Screening Strategies	7
1.2.1 High and Low Affinity Rolipram Binding Sites	7
1.2.2 PDE4 Subtype Selectivity	9
1.2.3 Tissue Targeting - Inhaled	11
1.3 PDE4 Inhibitors	11
Chapter 2	
2. Materials and Methods	14

Chapter 3

3. Results		22
3.1 Publication 2	<i>A comparison of the inhibitory activity of PDE4 inhibitors on leukocyte PDE4 activity in vitro and eosinophil trafficking in vivo.</i>	22
3.2 Publication 3.	<i>PDE4 inhibitors: new xanthine analogues</i>	25
3.3 Publication 4.	<i>Aryl sulfonamides as selective PDE4 inhibitors</i>	27
3.4 Publication 5.	<i>Synthesis and evaluation of a novel series of phosphodiesterase IV inhibitors: a potential treatment for asthma</i>	28
3.5 Publication 6.	<i>7-Methoxybenzofuran-4-carboxamides as PDE4 inhibitors: a potential treatment for asthma</i>	30
3.6 Publication 7.	<i>7-Methoxyfuro[2,3-c]pyridine-4-carboxamides as PDE4 inhibitors: a potential treatment for asthma</i>	32
3.7 Publication 8.	<i>8-Methoxyquinoline-5-carboxamides as PDE4 inhibitors: a potential treatment for asthma.</i>	34
3.8 Poster	<i>D4418 – A New PDE4 inhibitor for the treatment of asthma</i>	36
3.9 Publications 9/10	<i>8-methoxyquinolines as PDE4 inhibitors</i>	41
3.10 Publication 11	<i>Pharmacology of N-(3,5-dichloro-1-oxido-4-pyridinyl)-8-methoxy-2-(trifluoromethyl)-5-quinoline carboxamide (SCH 351591), a novel, orally active phosphodiesterase 4 inhibitor</i>	43

Chapter 4

4. Additional Work Published on SCH 351591	45
4.1 Toxicology	45
4.2 Additional Chemistry	46

Chapter 5

5. Discussion	47
5.1 Findings and Interpretations	47

5.2 Literature Citation	49
5.3 Contribution to Subsequent PDE4 Inhibitor Research	50
5.4 Conclusions	50
Chapter 6	
6. Evolution of Cited Clinical Development Candidates	52
6.1 Piclamilast(RP 73401)	52
6.2 CDP 840	52
6.3 Arofylline (LAS 31025)	52
6.4 Cilomilast (SB207499)	52
6.5 CP-671305	53
6.6 Tofimilast	54
6.7 Roflumilast (Daxas)	54
References	56
Appendix 1: Other Publications by Author	62
Appendix 2: Publications Submitted for this Thesis	63

Aims of Publications

The overall aim of this thesis was to study phosphodiesterase 4 inhibitors from a range of chemical classes and to assess if a drug with an improved therapeutic window could be identified for the treatment of respiratory inflammation.

The specific aims were as follows.

To assess correlations between inhibition of PDE4 enzyme activity, rolipram binding site antagonism, and modulation of eosinophil trafficking in the guinea pig skin eosinophilia model (publication 2).

To test the hypothesis that compounds with selectivity for PDE4 enzyme inhibition over rolipram binding site antagonism would exhibit anti-inflammatory activity at doses that would not result in nausea and vomiting (publications 3-7).

To further test two selected drugs in disease relevant animal models of airway inflammation and nausea and vomiting (publication 8, poster, publications 9, 10 and 11).

List of Research Publications

1. Phosphodiesterase (PDE) 4 inhibitors: anti-inflammatory drugs of the future?
Teixeira MM, Gristwood RW, Cooper N, Hellewell PG, Trends Pharmacol. Sci. 1997 May (18): 164-71.
2. A comparison of the inhibitory activity of PDE4 inhibitors on leukocyte PDE4 activity *in vitro* and eosinophil trafficking *in vivo*.
Cooper N, Teixeira MM, Warneck J, Miotla JM, Wills RE, Macari DM, Gristwood RW, Hellewell PG, *Br. J. Pharmacol.* **126**(8): 1863-71 (1999).
3. PDE4 inhibitors: new xanthine analogues.
Montana JG, Cooper N, Dyke HL, Gowers L, Gregory JP, Hellewell PG, Miotla J, Morris K, Naylor R, Tuladhar B, Warneck JB, *Bioorg. Med. Chem. Lett.* **8**(20): 2925-30 (1998).
4. Aryl sulfonamides as selective PDE4 inhibitors.
Montana JG, Buckley GM, Cooper N, Dyke HJ, Gowers L, Gregory JP, Hellewell PG, Kendall HJ, Lowe C, Maxey R, Miotla J, Naylor RJ, Runcie KA, Tuladhar B, Warneck JB, *Bioorg. Med. Chem. Lett.* **8**(19): 2635-40 (1998).
5. Synthesis and evaluation of a novel series of phosphodiesterase IV inhibitors: a potential treatment for asthma.
Beasley SC, Cooper N, Gowers L, Gregory JP, Haughan AF, Hellewell PG, Macari D, Miotla J, Montana JG, Morgan T, Naylor R, Runcie KA, Tuladhar B, Warneck JB, *Bioorg. Med. Chem. Lett.* **8**(19): 2629-34 (1998).
6. 7-Methoxybenzofuran-4-carboxamides as PDE4 inhibitors: a potential treatment for asthma.
Buckley G, Cooper N, Dyke HJ, Galleway F, Gowers L, Gregory JP, Hellewell PG, Kendall HJ, Haughan AF, Lowe C, Maxey R, Montana JG, Naylor R, Runcie KA, Tuladhar BR, Warneck JB, *Bioorg. Med. Chem. Lett.* **10**(18): 2137-40 (2000).
7. 7-Methoxyfuro[2,3-*c*]pyridine-4-carboxamides as PDE4 inhibitors: a potential treatment for asthma.
Buckley GM, Cooper N, Davenport RJ, Dyke HJ, Galleway FP, Gowers L, Haughan AF, Kendall HJ, Lowe C, Montana JG, Oxford J, Peake JC, Picken CL, Richard MD, Sabin V, Sharpe A, Warneck JB, *Bioorg. Med. Chem. Lett.* **12**(3): 509-12 (2002).
8. 8-Methoxyquinoline-5-carboxamides as PDE4 inhibitors: a potential treatment for asthma.
Buckley G, Cooper N, Dyke HJ, Galleway F, Gowers L, Haughan AF, Kendall HJ, Lowe C, Maxey R, Montana JG, Naylor R, Oxford J, Peake JC, Picken CL, Runcie KA, Sabin V, Sharpe A, Warneck JB, *Bioorg. Med. Chem. Lett.* **12**(12): 1613-5 (2002).

9. 8-Methoxyquinolines as PDE4 inhibitors.
Billah M, Buckley G, Cooper N, Dyke HJ, Egan R, Ganguly A, Gowers L, Haughan AF, Kendall HJ, Lowe C, Minnicozzi M, Montana JG, Oxford J, Peake JC, Picken CL, Piwinski JJ, Naylor R, Sabin V, Shih NY, Warneck JB, *Bioorg. Med. Chem. Lett.* **12**(12): 1617-9 (2002).
10. Synthesis and profile of SCH 351591 a novel PDE4 inhibitor.
Billah M, Cooper N, Cuss F, Davenport RJ, Dyke HJ, Egan R, Ganguly A, Gowers L, Hannah DR, Kendall HJ, Lowe C, Minnicozzi M, Montana JG, Naylor R, Oxford J, Peake JC, Piwinski JJ, Runcie KA, Sabin V, Sharpe A, Shih NY, Warneck JB, *Bioorg. Med. Chem. Lett.* **12**(12): 1621-3 (2002).
11. Pharmacology of *N*-(3,5-dichloro-1-oxido-4-pyridinyl)-8-methoxy-2-(trifluoromethyl)-5-quinoline carboxamide (SCH 351591), a novel, orally active phosphodiesterase 4 inhibitor.
Billah MM, Cooper N, Minnicozzi M, Warneck J, Wang P, Hey JA, Kreutner W, Rizzo CA, Smith SR, Young S, Chapman RW, Dyke H, Shih NY, Piwinski JJ, Cuss FM, Montana J, Ganguly AK, and Egan RW, *Bioorg. Med. Chem. Lett.*, **12**(12): 1621-3 (2002).

Poster

Activity of D 4418 a novel phosphodiesterase 4 (PDE4) inhibitor, effects in cellular and animal models of asthma and early clinical studies, Montana J, Cooper N, Dyke H, Oxford J, Gristwood R, Lowe C, Kendall H, Buckley G, Maxey R, Warneck J, Gregory J, Gowers L, Galleway F, Wills R, Naylor R, Tuladhar B, Broadley K, Danahay H, *ATS*, San Diego, USA, (1999).

List of Figures

- Figure 1.** *Relationship of PDE4 enzyme to G-protein coupled 7 transmembrane receptors and adenylate cyclase.*
- Figure 2.** *Inflammatory processes involved in asthma (adapted from references 21 and 22).*
- Figure 3.** *Schematic representation of the general structure of PDE4 genes.*
- Figure 4.** *Chemical structures of representative first and second generation PDE4 inhibitors.*
- Figure 5.** *PDE4 screening cascade.*
- Figure 6.** *Diagrammatical representation of PDE4 enzyme assay.*
- Figure 7.** *Structures of the PDE4 inhibitors used as standards to validate the PDE4 inhibitor screening cascade.*
- Figure 8.** *Structures of theophylline and the lead compound (3c) (from publication 3).*
- Figure 9.** *Structures of rolipram and the lead aryl sulphonamide (compound 20) (from publication 4).*
- Figure 10.** *Structure of the lead quinolone (7g) (from publication 5).*
- Figure 11.** *Chemical structures of rolipram, RP 73401 and the lead 7-methoxybenzofuran-4-carboxamide(3a) (from publication 6).*
- Figure 12.** *Chemical structures of the lead 7-methoxyfuro[2,3-c]pyridine-4-carboxamide (8a) (from publication 7).*
- Figure 13.** *Structure of D 4418.*
- Figure 14.** *Graphical representation of inhibition of antigen induced bronchoconstriction in the guinea pig by D 4418 at 10 mg/kg, p.o.*
- Figure 15.** *Graphical representation of inhibition of antigen induced bronchoalveolar cell infiltration in the guinea pig by D 4418 at 10 mg/kg, p.o.*
- Figure 16.** *Graphical representation of the effect on airway response to inhaled U46619 24 hrs after ovalbumin challenge in the guinea pig of 10 mg/kg D 4418 p.o.*

Figure 17.

Structures of SCH 365351 and its N-oxide metabolite SCH 351591,

List of Tables

- Table 1.** *A comparison of the known phosphodiesterase gene families in 2001 and 2007 (adapted from references 7-11).*
- Table 2.** *Summary of substrate specificity, tissue distribution and specific activators, and inhibitors, for the phosphodiesterase enzyme family (adapted from references 7 and 12).*
- Table 3.** *Grouping of functional effects of PDE4 inhibitors with their corresponding inhibitory activity at the low affinity (LARBS) or high affinity (HARBS) rolipram binding sites.*
- Table 4.** *Development status of 5 PDE4 inhibitors as representatives of different screening strategies employed by the pharmaceutical industry.*
- Table 5.** *Ratio of the IC_{50} in the PDE4 enzyme assay to the IC_{50} in the rolipram binding assay for the PDE4 inhibitors used as standards to validate the Chiroscience PDE4 inhibitor screening cascade.*
- Table 6.** *Ratio of the IC_{50} in the PDE4 enzyme assay to the IC_{50} in the rolipram binding assay for LAS 31025 and the lead xanthine (from publication 3).*
- Table 7.** *Guinea pig eosinophilia efficacious doses, ferret side effect doses and calculated therapeutic indices for rolipram and the lead aryl sulphonamide (from publication 4).*
- Table 8.** *Guinea pig skin eosinophilia efficacious doses, ferret side effect doses and calculated therapeutic indices for rolipram and the lead methoxybenzofuran-4-carboxamide (from publication 5).*
- Table 9.** *Ratio of the IC_{50} in the PDE4 enzyme assay, to the IC_{50} in the rolipram binding assay and PDE 3 data for rolipram and the lead benzofuran (from publication 6).*
- Table 10.** *Guinea pig eosinophilia efficacious doses, ferret side effect doses and calculated therapeutic indices for rolipram and the lead methoxybenzofuran-4-carboxamide (from publication 6).*
- Table 11.** *Pharmacokinetic parameters after oral dosing in guinea pig of the lead 7-methoxyfuro[2,3-c]pyridine-4-carboxamides (from publication 7).*
- Table 12.** *Ratio of the IC_{50} in the PDE4 enzyme assay, to the IC_{50} in the rolipram binding assay and PDE 3 data for Rolipram and the lead 7-methoxyfuro[2,3-c]pyridine-4-carboxamides (from publication 7).*

- Table 13.** *Ratio of the IC₅₀ in the PDE4 enzyme assay, to the IC₅₀ in the rolipram binding assay and PDE 3 data for rolipram the lead 8-methoxyquinoline-5-carboxamides (from publication 8).*
- Table 14.** *Guinea pig eosinophilia efficacious doses, ferret side effect doses and calculated therapeutic indices for rolipram and the lead 8-methoxyquinoline-5-carboxamides (from publication 8).*
- Table 15.** *In vitro profile for D4418.*
- Table 16.** *Pharmacokinetic parameters for 200 mg dose of D4418 in man.*
- Table 17.** *PDE isozyme selectivity for SCH 351591.*
- Table 18.** *PDE4 and RBA data for SCH 351591 and SCH365351.*
- Table 19.** *Pharmacokinetic parameters (C_{max} and AUC) for SCH 365351 and SCH 351591 its N-oxide metabolite in the guinea pig.*
- Table 20.** *Inhibition of cytokine release from human PBMC's by SCH 351159 and SB 207499.*

Abbreviations

<i>Symbol</i>	<i>Description</i>
AA	arachidonic acid
AC	adenylate cyclase
ADME	absorption, distribution, metabolism, excretion
5'AMP	5 prime adenosine monophosphate
ATP	adenosine monophosphate
ATS	American Thoracic Society
AUC	area under the curve
cAMP	cyclic adenosine monophosphate
cGMP	cyclic guanosine monophosphate
C_{max}	maximum plasma concentration
CNS	central nervous system
COPD	chronic obstructive pulmonary disease
EAR	early asthmatic response
ED₅₀	50% response on drug exposure
EHNA	<i>erythro-9-[2-hydroxyl-3-nonyl]-adenine</i>
eNANC	excitatory non-adrenergic non-cholinergic neuro transmission
ERS	European Respiratory Society
DC	dendritic cell
FDA	Food and Drug Administration
FEV₁	forced expiratory volume (over 1 second)
GI	Gastrointestinal
GOLD	global initiative for chronic obstructive pulmonary disease
GM-CSF	granulocyte macrophage colony stimulating factor
Gs	stimulatory g protein
HARBS	high affinity rolipram binding site
HIB	hyperventilation induced bronchospasm
HTS	high throughput screening
i.p.	Intraperitoneal
I.V.	Intravenous
IC₅₀	concentration at which 50% inhibition is achieved
IFNγ	interferon gamma
IL-1β	interleukin 1 β
IL-2	interleukin 2
IL-3	interleukin 3
IL-4	interleukin 4
IL-5	interleukin 5
IL-8	interleukin 8
IL-10	interleukin 10
IL-11	interleukin 11
IL-13	interleukin 13
LAR	late asthmatic response
LARBS	low affinity rolipram binding site
LPS	Lipopolysaccharide
LTs	Leukotrienes
MCP-1	monocyte chemotactic protein 1
MED	minimum efficacious dose

MND	maximum non-emetic dose
mRNA	messenger ribonucleic acid
NK	not known
O₂⁻	Superoxide
p.k.	Pharmacokinetics
p.o.	per os (oral)
PAF	platelet activating factor
PCA	passive cutaneous anaphylaxis
PDE	Phosphodiesterase
PGD₂	prostaglandin D ₂
PKA	protein kinase A
PMNPQ	6-(4-pyridylmethyl)-8-(3-nitrophenyl) quinoline
RANTES	regulated upon activation, normal T cell expressed and secreted
RBA	rolipram binding activity
SAR	structure activity relationship
sGaw	specific airway conductance
SPA	scintillation proximity assay
T_h	half-life
T_{h2}	T helper cell type 2
TNFα	tumour necrosis factor alpha
7TM	7 trans membrane
UCR1	upstream conserved region 1
UCR2	upstream conserved region 2

Chapter 1

1. Review of the Phosphodiesterase 4 Literature

The cyclic nucleotide phosphodiesterase (PDE) superfamily¹ are metallophosphohydrolases which uniquely control the rate of degradation and hence inactivation of the ubiquitous second messengers: cyclic nucleotides, adenosine 3'5'-cyclic monophosphate (cAMP) and guanosine 3'5'-cyclic monophosphate (cGMP). These cyclic nucleotides are generated by adenylyl cyclases (cAMP) and guanlyl cyclases (cGMP), respectively. The PDE's catalyse the insertion of a water-derived hydroxyl group at the phosphorous end of the cyclic phosphate ring to form the 5'-monophosphates.

To date 11 families of PDE enzymes² have been identified in mammalian tissues with a range of selectivities for cAMP and cGMP. The PDE subtype of interest in this thesis is PDE4. PDE4 is specific to cAMP and therefore catalyses the formation of 5'AMP. The cAMP is generated from ATP in a reaction catalysed by adenylyl cyclase. Adenylyl cyclase is activated by G stimulatory proteins (Gs) which are triggered via coupling to 7 transmembrane receptors (7TMs; Figure 1). An example of a 7TM which acts via Gs is the β_2 adrenoreceptor.

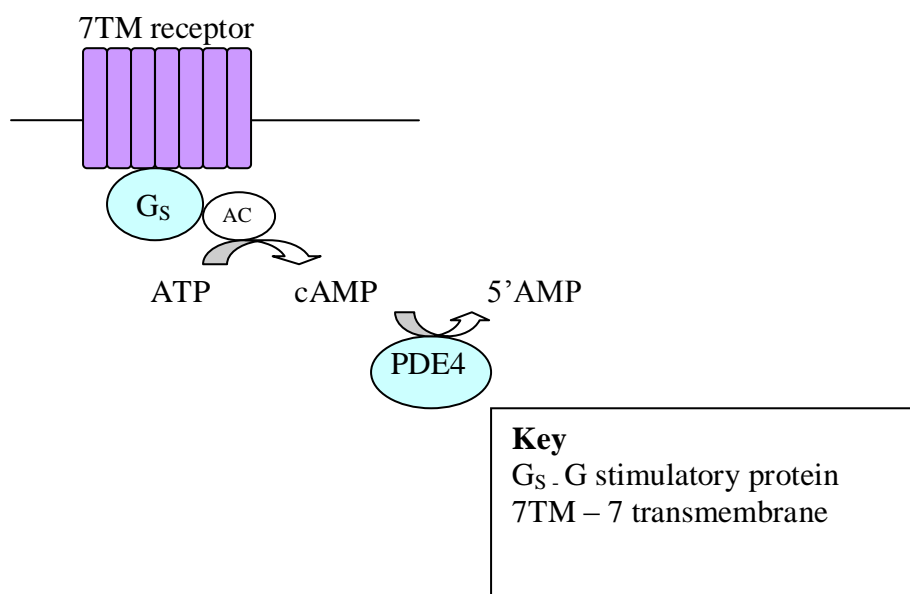

Figure 1. Relationship of PDE4 enzyme to G-protein coupled 7 transmembrane receptors and adenylyl cyclase.

PDE4 enzymes specifically hydrolyse cAMP with high affinity and are ubiquitously expressed throughout the body but more abundantly in inflammatory cells as well as lung, brain, liver, kidney and testes.³ PDE4 was first identified in 1987⁴ in human and guinea pig cardiac ventricle. This discovery led to the re-profiling of a previously considered selective PDE3 inhibitor, rolipram as a potent PDE4 inhibitor with PDE3 inhibitory activity and also to PDE4 being referred to as a rolipram-sensitive, low K_m , cAMP specific PDE.

Early work on PDE activity was carried out using saturating substrate concentrations.⁵ This was necessary due to the sensitivity of the assays employed. It was not until the introduction of radiolabelled substrates and higher resolution separation techniques that it became obvious that there were kinetically distinct forms of PDE activity in most tissues and that these isoforms also differed in their localisation and regulation methods. It is now known that there are 21 mammalian PDE genes in the 11 families⁶, referred to as PDE's 1-11 (Table 1), which have evolved from a single ancestral gene. This evolution was brought about by, duplication, divergence and generation of multiple isoforms from individual genes due to multiple transcriptional start sites and alternative mRNA splicing.

Table 1. *A comparison of the known phosphodiesterase gene families in 2001 and 2007 (adapted from references 7-11).*

PDE	2001		2007	
	Genes	Splice Variants	Genes	Splice Variants
1	3	9+	3	22
2	1	2	1	4
3	2	2+	2	4
4	4	15+	4	31
5	2	2	1	3
6	3	2	3	3
7	1	1	2	7
8	1	1	2	7
9	1	NK	1	20
10	NK	NK	1	10
11	NK	NK	1	4

NK-not known

The PDEs are classified by their substrate selectivity, sensitivity to exogenous activators and inhibitors, sub-cellular localization and tissue distribution. Table 2 is an attempt to summarise this extensive information on each of the 11 PDEs.

Table 2. Summary of substrate specificity, tissue distribution and specific activators and inhibitors, for the phosphodiesterase enzyme family (adapted from references 7 and 12).

PDE	Substrate Km (μ M)		Activator	Inhibitor	Tissue Distribution
	cAMP	cGMP			
1	1-30	3	Calcium calmodulin activated	Vinpocetine	CV system, brain, immune cells, testes, sperm
2	50	50	cGMP stimulated	EHNA	Brain, thymocytes, macrophages, heart, fibroblasts, platelets, endothelial cells, adrenal cortex
3	0.2	0.3	cGMP inhibited	Amrinone, Cilostamide	Adipocytes, hepatocytes, β cells, platelets, heart, vascular smooth muscle, oocytes, spermatocytes
4	4	>3000	cAMP specific	Rolipram	Brain, immune cells, heart, kidney, liver, lung, muscle, pancreas, placenta
5	150	1	cGMP specific	Zaprinast, Sildenafil	Smooth muscle, lung, platelets, GI epithelial cells, pulmonary artery, kidney, pancreas, lung, vagina, penis
6	900	14	Photoreceptor	Zaprinast	Rod and cone photoreceptors, photoreceptive tissues
7	0.2	>1000	High affinity cAMP specific	None identified	Skeletal and cardiac muscle, T & B lymphocytes, brain, testis, spleen, thymus, pancreas, lung, kidney, placenta, pro-inflammatory cells
8	0.05	>1000	cAMP specific IBMX insensitive	Dipyridamole	Testis, ovary, small intestine, kidney, colon, spleen
9	230	0.17	cGMP specific	Sildenafil, Zaprinast	Brain, lung, testis, spleen, liver, kidney, gut, pancreas, ovary, heart, thymus, prostate, skeletal muscle
10	0.05	3	Possibly cAMP regulated	Papaverine	CNS, testes
11	5.7	4.2	cAMP and cGMP hydrolysing	Tadalafil	Prostate, testis, salivary gland, pituitary, kidney, liver

Nucleotide selectivity is conferred by the amide group of an invariant glutamine in the active site of the PDE which adopts one orientation to interact with cAMP and flips 180° to interact with cGMP.¹³ This glutamine switch is locked in PDE4 to confer selectivity for cAMP.

Rolipram, the archetypal selective PDE4 inhibitor was originally clinically tested for the treatment of CNS disorders. The trials were initially focussed on depression¹ in

which an early open-label study suggested good efficacy. This was not, however, maintained in later studies and side effects of nausea and vomiting limited dose escalation possibilities. Later trials in Parkinson's patients were again promising from an efficacy perspective but fraught with the same nausea and vomiting side effects. Indeed the most common side effect observed with all of the selective PDE4 inhibitors tested to date is nausea and emesis, alongside headache. Theories as to whether the effects were driven by the central nervous system (CNS) or were due to local effects on the GI tract led to work being carried out in both areas.

Carpenter et al¹⁴ found that neuronal firing in the dog area postrema could trigger the emetic reflex to specific receptors for a variety of transmitters all of which had a common second messenger, cAMP. When PDE4 inhibitors were given to the dogs the receptor transmitters evoked emesis at lower concentrations due to an up-regulation in cAMP. These results demonstrated a central role for PDE4 inhibitors in emesis. In a study in rabbits, to examine the involvement of the GI tract, rolipram was found to be a potent stimulator of gastric acid secretion.¹⁵ This secretion may produce local irritation and exacerbate GI disturbances, resulting in nausea and emesis suggesting an involvement of the GI tract in PDE4 inhibitor-induced emesis.

The anti-inflammatory asthma drug theophylline, which had been used for many years, was found to have weak inhibitory activity against PDE4. This observation alongside PDE4 protein expression studies which found PDE4 to be expressed in a wide range of inflammatory cells including mast cells/basophils, eosinophils, neutrophils, monocyte/macrophages and lymphocytes^{16,17} led research on PDE4 inhibitors away from CNS disorders towards diseases with an inflammatory component, including asthma, chronic obstructive pulmonary disease (COPD), rheumatoid arthritis, atopic dermatitis, multiple sclerosis and allergic rhinitis, with the primary focus being the respiratory diseases, asthma and COPD.

Via functional studies, PDE4 has been found to play a key role in inflammatory cells including:

- inhibition of LTC₄ and histamine release, tryptase activity, superoxide production and adhesion in mast cells and basophils.^{16,17}
- inhibition of LTC₄, basic proteins and superoxide release adhesion and chemotaxis in eosinophils.^{16,17,12}
- inhibition of PAF, superoxide, and lysozyme release and adhesion in neutrophils.^{16,17}
- inhibition of arachidonate and TNF α release in monocytes and macrophages.^{16,17, 75}
- inhibition of IFN γ , IL-2, IL-4, and IL-5 and proliferation in lymphocytes.^{16,17}
- inhibition of TNF α release in dendritic cells.¹⁸

All of these inflammatory mediators are of clinical importance in lung inflammation, their role in asthma is outlined in Figure 2. The role of T cells within inflammatory airway disease has changed substantially in recent years. In 2004¹⁹ T_{H2} cells were thought to be the predominant CD4+ cell in asthmatic airways responsible for secreting cytokines, which affect B cells (IL-4 and 13 drive IgE production), eosinophils (IL-5 promotes eosinophil differentiation and chemotaxis), and mast cells (IL-9 drives differentiation and chemotaxis). In COPD patients T_{H1} cells were also

thought to be the predominant CD4⁺ cells. This definition however has now been found not to be absolute²⁰ as T_{H2} cells have been found in bronchoalveolar lavage fluid from COPD patients and T_{H1} cells have been shown to be active in patients with more severe asthma.

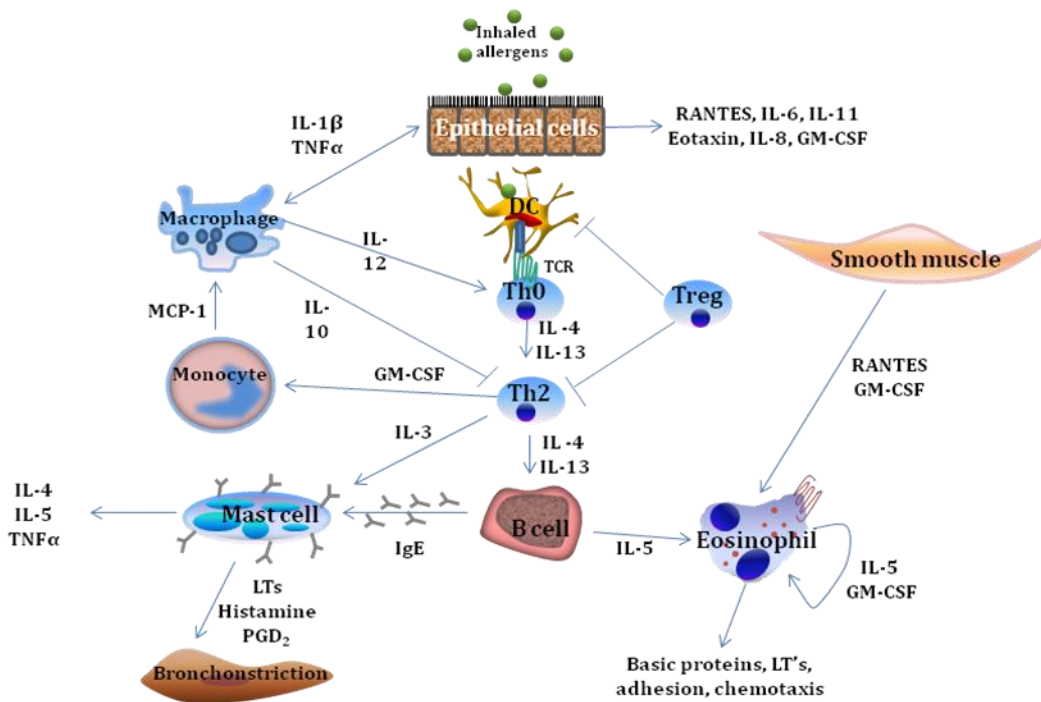

Figure 2. *Inflammatory processes involved in asthma (adapted from references 21 and 22).*

1.1 Respiratory Disease

Early PDE4 inhibitor programmes were focussed on the production of drugs to treat respiratory disease due to the tissue distribution of PDE4 in both respiratory and immune tissues and the clinical use of the weak PDE4 inhibitor theophylline in asthma. The PDE4 respiratory story began with Henry Hyde Salter in 1886,²³ an asthmatic who noticed that when he drank coffee on an empty stomach his breathing eased due to the bronchodilator activity of caffeine. The mechanistic explanation for this phenomenon was not known at the time. Subsequently it has been shown that caffeine, a xanthine, is a weak, non-selective PDE inhibitor.

1.1.1 Chronic Obstructive Pulmonary Disease

Chronic respiratory diseases such as chronic obstructive pulmonary disease (COPD) and asthma show symptoms such as shortness of breath, coughing and wheezing. Asthma is also characterised by episodic, night time and allergen induced chest symptoms whereas COPD patients may have a daily morning cough that produces mucus and persistent chest symptoms throughout the day. COPD is the fourth leading cause of chronic morbidity and mortality in the United States and is projected to rank fifth in 2020 in worldwide burden of disease. In 1998 the Global Initiative for Chronic

Obstructive Lung Disease (GOLD) was formed to increase awareness of COPD and to help the millions of sufferers of this disease and those who die prematurely of its complications.²⁴ Current therapies for COPD²⁵ are aimed at reducing disease severity by reducing frequency and severity of exacerbations and improving health status and exercise tolerance. None of the drugs currently available are able to affect the long-term decline of lung function, a characteristic of the disease. Treatment tends to be cumulative with increasing numbers of interventions being used as the disease worsens. The order in which the drugs would normally be introduced is:-

1. short-acting, then long-acting β -agonists,
2. short-acting, then long-acting anti-cholinergics,
3. β_2 -agonists and anti-cholinergics in the same inhaler,
4. methylxanthines,
5. inhaled glucocorticosteroids,
6. combination β_2 -agonists and glucocorticosteroids in the same inhaler, and
7. systemic glucocorticosteroids.

1.1.2 Asthma

Current therapies for asthma as outlined in the British Thoracic Society Guidelines²⁵ are aimed at symptom management, control of exacerbations, achieving the best pulmonary function and minimising side effects. The current drugs used for asthma are also given in a step-wise manner, dependent on the severity of the asthma and the effectiveness of the drug. The order in which the drugs would normally be introduced is:-

1. short-acting β_2 -agonists taken as required
2. inhaled steroids
3. long acting β_2 -agonists
4. increasing doses of inhaled steroids
5. theophylline, leukotriene receptor antagonists or oral β_2 -agonists
6. in very severe cases orally administered steroids are used with add-ons in the form of anti-IgE (omalizumab) and immunosuppressants⁷⁹.

The drugs, therefore, recommended to treat the underlying inflammation in these respiratory diseases are steroids, which can have extremely harmful side effects when given at high doses via inhalation or when dosed systemically. Side effects include, hypercorticism and adrenal suppression, Cushing's syndrome, obesity, acne, psychiatric disorders, menstruation disorders, osteoporosis, muscular atrophy, and other myopathies, hypertension, oedema, hyperglycaemia, cataracts, glaucoma, aseptic bone necrosis, pancreatitis, delayed wound healing, sleep disturbances, nausea, gastrointestinal bleeding, congestive heart failure, convulsions, and impaired wound healing. These side effects mean that the administration of steroids needs to be very closely monitored and limit the degree of disease severity in which they may be given, leaving poor coverage of inflammatory components of the milder disease states. PDE4 inhibitors potentially offer a 'safer' alternative to steroids in treating respiratory inflammation or an opportunity to limit their use by being 'steroid sparing'.

1.2 Screening Strategies

The challenge for the pharmaceutical industry has been to develop potent selective PDE4 inhibitors as anti-inflammatory agents with a broad therapeutic window in the central nervous system and GI side effects. At the time the publications were submitted, as part of this thesis, a number of screening strategies had been designed to improve the selection of such agents. These included selectivity for the PDE4 low affinity binding site or catalytic site over the high affinity rolipram binding site, PDE4 subtype selectivity, and topical lung delivery. These three approaches are outlined in more detail below.

1.2.1 High and Low Affinity Rolipram Binding Sites

Due to the promising trials for rolipram as an anti-depressant in the 1980s several enzymatic studies³¹ were carried out in CNS tissues to confirm PDE4 (or cAMP PDE, as it was known at that time) inhibitory activity to be responsible for the pharmacology observed for rolipram. Selectivity for PDE4 was observed in these studies and in 1986 Schnieder³² showed specific binding sites for rolipram in several CNS tissues from various species. Binding to a number of tissues including brain and spinal cord was determined using radiolabelled rolipram as the ligand, and confirmed to represent PDE4 activity by the use of specific inhibitors. Binding affinities for rolipram varied across tissues; when CNS derived materials were studied high affinities for rolipram were mostly observed, but in tissues from other sources only negligible or very low specific binding was found. Based upon this work Schneider concluded that there were two distinct binding sites for rolipram, a high affinity rolipram binding site (HARBS) present in CNS tissues and a low affinity rolipram binding site (LARBS) also present in brain tissue but also common to some peripheral tissues. Binding affinities for this high affinity rolipram binding site in rat brain were determined and the IC₅₀ for (-)-rolipram (rolipram is a racemate and binding for the two isomers is stereoselective) was 2.4 nM and for (+) rolipram 50 nM. When PDE4 was subsequently purified from the same tissue³² and an enzyme assay performed using cAMP as substrate the IC₅₀ for racemic rolipram was ~1 μM showing, under these conditions, the low affinity site.

To confirm that the high affinity rolipram-binding site (HARBS) was in fact PDE4, studies were carried out in yeast.³³ *Saccharomyces cerevisiae* was genetically engineered to express *hPDE4* (human recombinant monocyte cAMP specific PDE4) and whole yeast lysates were taken at time intervals post induction and assayed for rolipram binding and PDE enzymatic activity. The two activities were found to increase in parallel showing both activities to be properties of the same PDE4 protein.

Identification of HARBS in brain led to the search for this site in peripheral tissues. PDE4 in guinea pig eosinophils³⁴ is tightly membrane bound and has an IC₅₀ for rolipram of approximately 200 nM. Solubilisation to release PDE4 from the membrane results in greater than 10 fold increase in potency of rolipram, suggesting a change in conformational state. The solubilisation process was therefore thought to reveal the high affinity site in an inflammatory cell type not just in the brain, as was previously speculated.

In 2000 Laliberte et al reported that the rolipram binding site³⁵ is a consequence of PDE4 binding to a divalent metal cofactor such as Mg^{2+} , as metallophosphohydrolase PDEs require the presence of divalent cations for their activity. In the crystal structure of PDE4B the presence of two divalent cations was identified at the bottom of the deep active site. The cations appear to be involved in cAMP binding and enhance its catalysis to 5'AMP. Free PDE4 is referred to as the apoenzyme and cofactor bound PDE4 as the holoenzyme. (*R*)-rolipram was shown to bind to both the holoenzyme and the apoenzyme with affinities (K_d) of 5 and 300 nM, respectively. Other PDE4 inhibitors bound preferentially to the holoenzyme (IC_{50} 's (CDP 840, 10nM, RP 73401, <5nM, SB207499, 100nM) with IC_{50} 's of greater than 500nM against the apoenzyme. cAMP was shown to bind actively to the holoenzyme complex with a K_d of 2 μ M and non-productively to the apoenzyme with a lower affinity of 170 μ M demonstrating in this case cofactor binding to be responsible for activating catalysis and eliciting high-affinity interaction with cAMP. This research group later refined the work³⁶ using more sensitive assay technology (SPA) and determined that Mg^{2+} , Mn^{2+} and Co^{2+} all mediated high affinity rolipram binding to PDE4.

The upstream conserved regions (UCR1 and UCR2) present on the long forms of the PDE4 genes mediate enzyme dimerisation; short forms of the PDE4, enzyme which lack UCR1 are found only as monomers. In a publication by Richter et al in 2004,³⁷ dimerisation was outlined as an important factor in stabilising PDE4 long forms in their high affinity state. Disruption of dimerisation using PDE4D3 monomeric mutants reduced the sensitivity of the enzyme towards rolipram possibly due to a decrease in the number of inhibitor binding sites in the high affinity rolipram binding state.

The assay conditions commonly used to determine HARBS activity is a ligand displacement assay which detects competitive inhibition of [³H]rolipram binding to rat brain tissue.³² The low affinity binding site (LARBS) activity is determined in a catalytic assay involving hydrolysis of cAMP to 5'AMP using recombinant, purified or partially purified PDE4 enzyme from a range of sources.

To investigate the functional outputs that result from HARBS and LARBS activity a number of research groups carried out a series of studies examining the potency at the two putative sites and how they track with pharmacological activity of rolipram and other inhibitors across different biological systems. These results of these studies are summarised in Table 3.

Table 3. Grouping of functional effects of PDE4 inhibitors with their corresponding inhibitory activity at the low affinity (LARBS) or high affinity (HARBS) rolipram binding sites.

LARBS	HARBS
Inhibition of superoxide production by guinea pig eosinophils ³⁸	Enhanced acid secretion of isolated rabbit parietal cells ¹⁵
Attenuation of TNF α production from human monocytes ³⁹	Human neutrophil degranulation ³⁸
Potentialiation of PGE ₂ induced cAMP accumulation in monocytes ³²	CNS actions – antagonism of reserpine induced hypothermia in mice, head twitches in rats etc. ²⁴
Inhibition of <i>Staphylococcus Aureus</i> enterotoxin A – induced IL-2 production in murine splenocytes ³⁴	Inhibition of histamine induced contraction in guinea pig trachea ³⁴
	Potentialiation of isoprenaline induced cAMP accumulation in guinea pig eosinophils ³⁴
	Nausea and emesis ²⁴

The grouping given in Table 3 of functional effects of PDE4 inhibitors with their corresponding activity at the low affinity or high affinity rolipram binding sites provide a powerful argument for selecting compounds which selectively bind to the LARBS over the HARBS as they show that activity against HARBS tracks with the classic central nervous system (CNS), and gastrointestinal (GI) nausea and emesis side effects observed with PDE4 inhibitors both pre-clinically and clinically whereas the anti-inflammatory activity is more closely associated with LARBS. Indeed these arguments were so powerful to SmithKline Beecham that they filed a patent⁴⁰ in 1993 to try and prevent other companies from using this method of drug selection even though the mechanistic basis for the activity differences of certain inhibitors including rolipram against the HARBS and LARBS sites was yet to be elucidated.

1.2.2 PDE4 Subtype Selectivity

A second approach for attempting to improve the therapeutic index for PDE4 inhibitors was to examine PDE4 subtype selectivity.

PDE4 genes are the mammalian PDEs with most homology to the ‘dunce’ gene of *Drosophila* which was the first PDE gene isolated by Chen et al in 1986.²⁶ As outlined in Table 1, four PDE4 genes have been identified to date with at least 20 splice variants. The N-terminal splice variants are believed to be important for targeting of the isoforms to their specific intracellular sites. The resulting multiplicity of differentially expressed and regulated isoenzymes suggests that distinct PDE4 enzymes encoding for efficacy and side effects may exist and if this is the case it may be possible to identify compounds with improved side effect profiles targeted at inhibition of the ‘efficacy’ of PDE4 isoenzyme²⁷ whilst avoiding activity at the ‘side effect’ PDE4 isoenzyme.

The PDE4 genes are termed PDE4A, B, C, and D¹ and their general structure is shown in Figure 3.

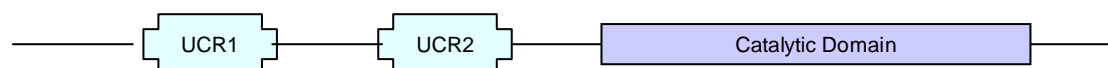

UCR – upstream conserved region

Figure 3. Schematic representation of the general structure of PDE4 genes.

PDE4 (Table 2), can be distinguished from other cAMP specific PDEs (such as PDEs 7 and 8) by cAMP affinity, catalytic domain structure, inhibitor specificity and the presence of 2 amino acid sequences known as upstream conserved sequences 1 and 2 (UCR1 and 2).¹ The PDE4 isoforms are generated by alternate mRNA splicing and the use of different promoters. The various isoforms are split into 3 groups: long forms which contain both UCR1 and 2, short forms which contain only UCR2, and the super-short forms which only contain half of UCR2. The isoforms differ in their enzymatic properties and tissue distribution.

When efficacy of PDE4 inhibitors is observed in respiratory disease these molecules are considered to act mainly as anti-inflammatory agents rather than bronchodilators. Therefore the PDE4 subtypes found in inflammatory cells with a role in their function are of most interest to inhibit. If tissue distribution of the PDE4 subtypes is examined PDE4A, PDE4B, and PDE4D have been found in all inflammatory cells (Figure 2) in which PDE4 inhibitory activity has been studied whereas PDE4C activity has only occasionally been reported in these cells.²⁸ This information suggests that PDE4C can be eliminated on the basis of distribution. To find out if a correlation could be found between anti-inflammatory activity and PDE subtype, a study²⁸ examining the effects of PDE4A/B and PDE4D selective inhibitors on antigen stimulated T cell proliferation and LPS stimulated TNF α release from human PBMCs was carried out. The results showed the two activities to be more responsive to the PDE4A/B inhibitors than the PDE4D inhibitors suggesting that PDE4A and/or B may play the major role in regulating these two inflammatory cell functions. Both T cell proliferation and TNF α release are important components in inflammatory respiratory diseases such as asthma. Further studies²⁹ have shown that PDE4B appears to be the predominant species in inflammatory cells including monocytes and neutrophils making this the preferred target for anti-inflammatory activity.

To try and ascertain if there was a specific PDE4 subtype responsible for emesis Robichaud et al³⁰ used a behavioural correlate of emesis, reversal of α_2 -adrenoceptor-mediated anaesthesia induced by xylazine/ketamine in a non-vomiting species, the mouse. The mice used were deficient in PDE4D or PDE4B with wild-type litter mates used as comparators. No effects were found on anaesthesia times in PDE4B knockout animals; only PDE4D, where sleeping times were shortened when compared to wild-type animals. When looking at rolipram-sensitive PDE activity in the brain stem a decrease was observed only in PDE4D-deficient mice. These findings suggest that the inhibition of the PDE4D enzyme subtype is likely to be responsible for emesis induction by PDE4 inhibitors.

From these studies it would appear that inhibitory activity against PDE4B would be beneficial from an anti-inflammatory efficacy perspective and that PDE4D inhibitory activity would be detrimental due to its apparent association with emetic side effects.

1.2.3 Tissue targeting - inhaled

As already mentioned the nausea and emesis side effects caused by PDE4 inhibitors are thought to be largely due to actions of the drugs within the brain and GI tract. As the primary indication for these drugs is pulmonary inflammation it was thought that direct delivery to inflamed tissue via inhalation would result in the required efficacy whilst avoiding systemic exposure and subsequent side effect activity. This has been a successful approach for the muscarinic antagonist, glycopyrronium bromide⁴¹ which is in clinical trials for use as a bronchodilator in COPD. In a rabbit model direct delivery to the lung of glycopyrronium bromide has been shown to result in the required bronchodilation effects but not the unwanted cardiovascular side effects. This is probably due to inactivation of the drug after absorption from the lungs into the blood stream reducing its pharmacokinetic exposure to other organs including the heart.

All of these approaches have been examined by the drug industry at various levels. Details of some of the lead compounds from these drug discovery programmes are discussed in Section 1.3.

The approach taken for the work carried out as part of this thesis was selection of compounds with selectivity for the low affinity rolipram binding site over the high affinity rolipram binding site.

1.3 PDE4 Inhibitors

The PDE4 inhibitors can, arguably, be separated into 2 generations of compound (Figure 4). The first generation consists of the non-selective xanthines such as theophylline and denbutylline and the potent but emetic compounds such as rolipram and piclamilast (RP 73401). The compounds made subsequent to these with the aim of improving potency, selectivity and side effect profiles are termed second generation, compounds.

A number of, second generation PDE4 inhibitors are cited in Table 4 as representatives of the different screening paradigms; more details are provided in Chapter 6.

Table 4. *Development status of 5 PDE4 inhibitors as representatives of different screening strategies employed by the pharmaceutical industry.*

Compound (trade name)	Other names	Company	Development Status Achieved	Comment on Clinical Status	Screening strategy
Roflumilast (Daxas)	-	Altana	EU approved COPD	FDA reviewing recent refusal	Rolipram analogue
Cilomilast (Ariflo)	SB 207499	Glaxo Smith Kline	Phase II/III	Discontinued asthma 2003 COPD 2008*	Selectivity LARBS over HARBS
Arofylline	LAS 31025	Almirall Prodesfarma	Phase II/III Phase I inhalation ⁴⁰	Detailed status unknown	Xanthine – theophylline like
CP-671305	-	Pfizer	Preclinical	PDE4D found to be associated with emesis ²⁸	PDE4 subtype selectivity (PDE4D)
Tofamilast	-	Pfizer	Phase I/IIa	No significant activity in Phase IIa asthma study ⁴¹	Inhaled

*Comment from - Investigational Drugs Database 3

LARBS – low affinity rolipram binding site

HARBS – high affinity rolipram binding site

EU – European Union

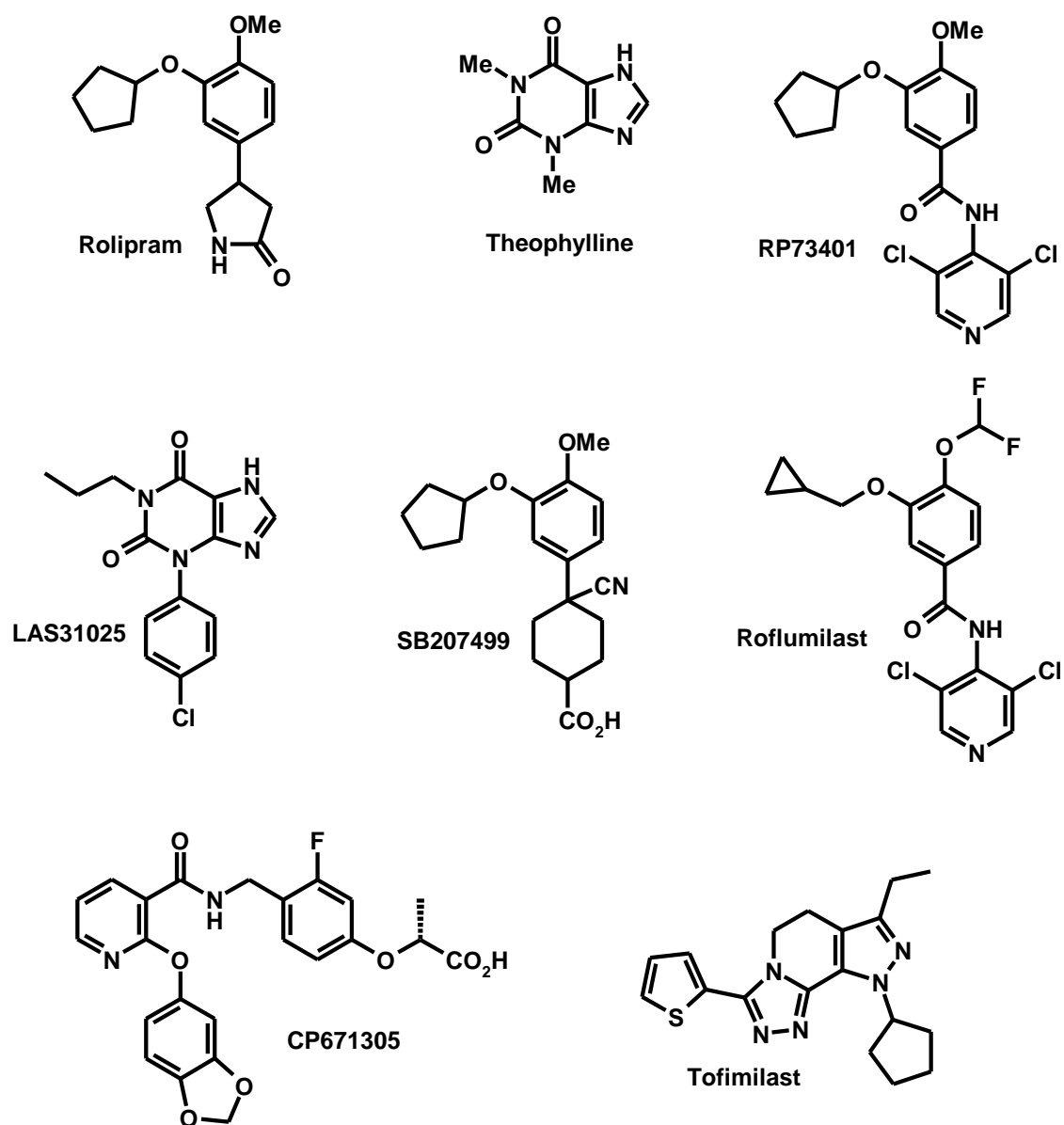

Figure 4. *Chemical structures of representative first and second generation PDE4 inhibitors.*

Chapter 2

2. Materials and Methods

This thesis comprises one review paper (publication 1), one exploratory study to investigate *in vitro* and *in vivo* correlations of enzyme affinity and functional pharmacology (publication 2), seven publications testing compounds from a number of chemical classes (publications 3-9) as well as two publications and a poster which highlight the extended pharmacological profile of two molecules selected as development candidates (publication 9 and 10 and poster number 4). The assays and models used are shown in Fig.5 (the assays performed are shown in boxes and the decision making criteria in diamonds).

More than 800 compounds were synthesised and tested in the screening cascade represented below. Not all of the compounds progressed into the *in vivo* assays. The chemical classes explored and their lead compounds, which were progressed, are outlined in publications 3-9.

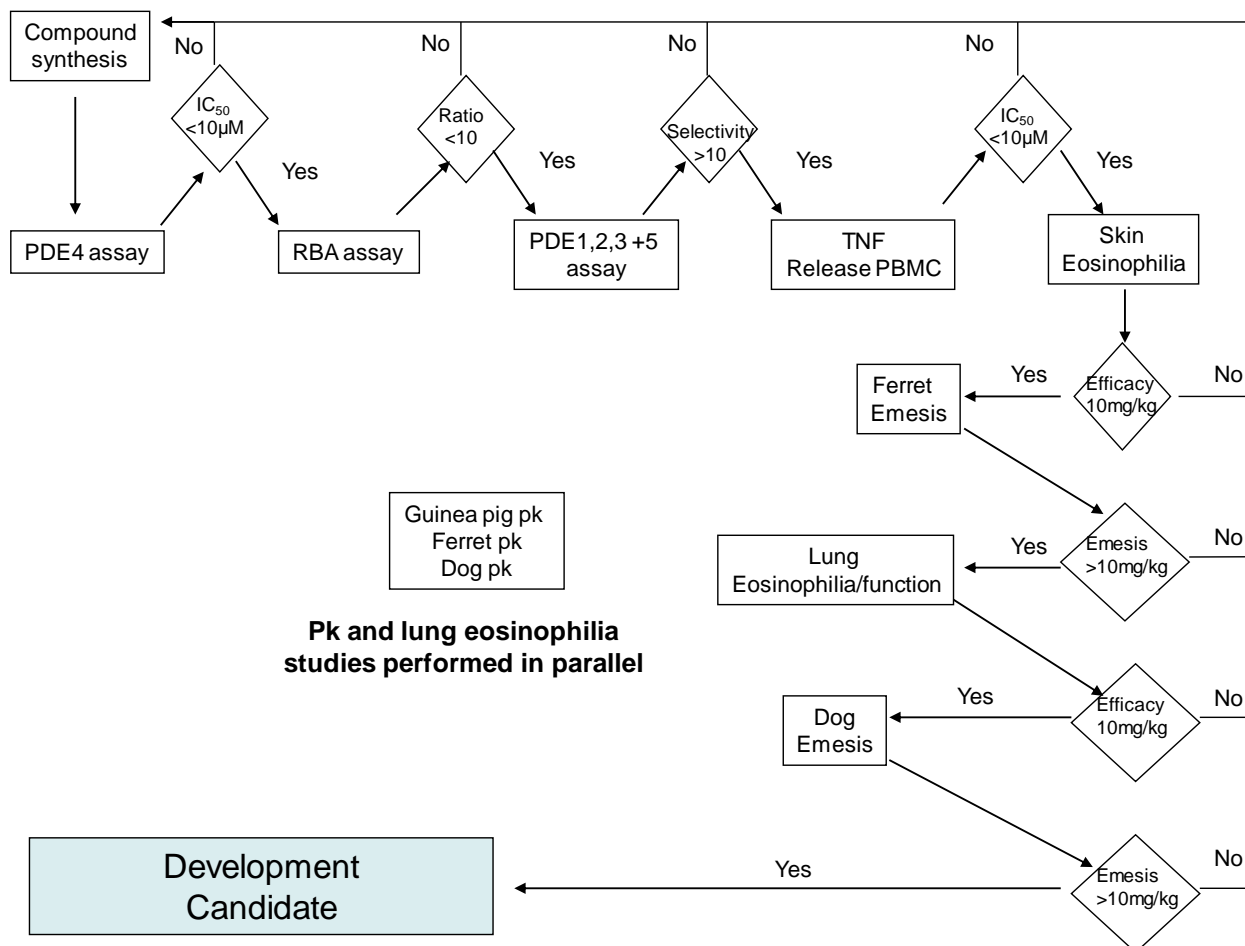

Figure 5. *PDE4 screening cascade.*

The first publication submitted as part of this PhD thesis is a review of the use of PDE4 inhibitors as anti-inflammatory drugs. This publication outlines why a new class of anti-inflammatories would be useful, what diseases they could treat and why, the *in vivo* inflammatory disease models where PDE4 inhibitors are effective, mechanisms for the action of PDE4 inhibitors in these models, and the clinical prospects for PDE4 inhibitors given their side effect limitations.

The disease area of interest for the clinical utility of PDE4 inhibitors is chronic inflammation in respiratory disease. The mainstay anti-inflammatory therapy for asthma at the time of the review was steroids, which have harmful effects when used chronically e.g. immuno-suppression, metabolic disturbances and hypertension.

On review of the literature for the effects of PDE4 inhibitors in *in vivo* experimental models of inflammation examples of the class, mainly rolipram, were seen to be effective in a range of models a large number of which were associated mechanistically with asthma. Cross referencing this to *in vitro* cellular data, a strong effect for PDE4 inhibitors on a key asthma inflammatory cell, the eosinophil, was observed with effects on respiratory burst, enzyme release, chemotaxis and elevation of intracellular calcium. Asthma, therefore, appeared to be a disease poorly served by anti-inflammatory agents and approachable from a drug discovery perspective due to the wealth of *in vivo* asthma-like animal models, pre-validated with steroids, in which PDE4 inhibitors had been shown to be effective.

Of the animal models included in the review the allergic monkey model is probably the most relevant to human asthma being in primates and in spontaneously occurring allergic animals rather than as a result of ovalbumin sensitisation. False positives have however occurred in this model such as the IL-5 antibody developed by Schering Plough which showed good efficacy against lung eosinophil infiltration in the model but failed to reproduce this efficacy in the clinic. Also as a method of testing a large number of molecules the monkey is not ethically suitable.

The most common species used in the *in vivo* models of asthma was the guinea pig, In the guinea pig it is possible, in some models, to measure more than one parameter such as bronchoconstriction, bronchoalveolar inflammatory cell influx and airway hyper-reactivity (response of sensitised airways to antigens which are innocuous to un-sensitised animals such as adenosine). The guinea pig lung model involving eosinophilia alone appeared to be the most relevant and accessible animal model for *in vivo* screening of PDE4 inhibitors for use in respiratory disease with the more complex model additionally measuring bronchoconstriction and hyper-reactivity for compounds which achieved late stage validation in the screening cascade. These models require fairly large group sizes to ensure reproducibility and look at both the direct effects of inhibitors on eosinophil chemotaxis and indirect effects on T cells and macrophages, which result in eosinophil chemotaxis.

Another *in vivo* model in the guinea pig was the skin eosinophilia model. Though this model did not involve the respiratory system it did examine, directly, eosinophil chemotaxis against a range of stimuli making it relevant to the inflammatory component of asthma. The model involved the measurement of labelled ¹¹¹In-

eosinophils and local oedema formation induced by intra dermal injection of the inflammogens, zymosan-activated plasma (ZAP), plasminogen activating factor (PAF), histamine, arachidonic acid (AA) and passive cutaneous anaphylaxis (PCA). The measurement of radioactively labelled eosinophils allows quantification of specific eosinophil infiltration rather than oedema formation only as observed in more traditional skin inflammation models such as the Evans Blue oedema model. This feature confers greater reproducibility on the model. Specificity⁴⁴ for PDE4 inhibitors had been demonstrated in this model via i.p. or i.v dosing and, rolipram had been found to inhibit eosinophil accumulation in response to inflammogen whereas SK&F 94120 (PDE3 inhibitor) and zaprinast (PDE5 inhibitor) did not. In the same model⁴⁴ the PDE4 inhibitors of clinical relevance at the time, rolipram, RP 73401⁴⁵ and CDP 840⁴⁶ were tested via the oral route.⁴⁸ Rolipram and RP 73401 were found to be equipotent at inhibiting ¹¹¹In-eosinophil recruitment by PCA at 0.01, 0.1 and 1 µg of antigen/site, with significance seen at 2 mg/kg; CDP 840 failed to reach significance at the dose tested but did show some inhibition. In summary this model required fewer animals for reproducibility, lower doses for efficacy and simultaneously examined a range of inflammatory mediators (PAF (plasminogen activating factor), ZAP (zymosan activated plasma), PCA (passive cutaneous anaphalaxis to bovine gamma-globulin), histamine and AA(arachidonic acid)).

In a number of the *in vivo* models examined in publication 1, PDE4 inhibitors were found to affect a range of cytokines either by attenuation of their release (serum TNF α in septic shock models in mice and rats, and in an acute respiratory distress model in rats and IL-1 β , IL-6 and IL-8 in a monkey asthma model) or via inhibition of inflammatory processes driven by them (IL-5, IL-8 driven eosinophila in guinea pigs and rats). All of the cited cytokines have been implicated to have a role in asthma.¹ TNF α , IL-1 β and IL-6⁷⁶ are found in increased amounts in the sputum and BAL fluid of patients with COPD and asthma. These cytokines amplify inflammation partly via NF κ -B activation. In COPD IL-1 β and TNF α ⁷⁷ stimulate macrophages to produce matrix metalloproteinase-9 and bronchial epithelial cells to produce extracellular matrix glycoproteins. IL-5⁷⁶ has a key role in eosinophil mediated inflammation in asthma as it is involved in the differentiation of eosinophils from bone marrow precursor cells and also prolongs eosinophil survival. Systemic and local administration of IL-5 to asthmatics⁷⁶ increases eosinophil and CD34⁺ eosinophil precursors in the systemic population. IL-8⁷⁷ is a chemokine responsible for sputum neutrophil chemotaxis. TNF α is a pro-inflammatory cytokine released early in the inflammatory cascade in asthma on allergen stimulation of macrophages.¹ To show effects against this particular cytokine could, therefore, be the key to dampening down the deregulated immune response in asthma patients.

When examining the clinical prospects for potential development candidates it was observed that in clinical trials PDE4 inhibitors induced nausea and emesis and that the mechanisms by which this occurred were poorly understood, but that based on animal studies some correlation with these effects and activity at the rolipram binding site had been drawn.

The conclusions drawn from this review, which were the basis of the design of the screening cascade, were as follows:

1. There was an unmet medical need for a new class of anti-inflammatories in a number of diseases including asthma, rheumatoid arthritis and multiple sclerosis.
2. *In vivo* disease models were available for a number of therapeutic indications where PDE4 inhibitors are found to work against parameters measured clinically. Importantly, drugs used therapeutically in these disease areas are also seen to work in these models validating them as translational models.
3. The guinea pig skin model which also looks at eosinophils was considered a good early screening model due to its specificity for eosinophils, its reproducibility and ability to be performed in a small number of animals, to be followed by the guinea pig lung model for successful compounds and in a limited number of compounds the allergic monkey model.
4. The selection of the release of TNF α from LPS stimulated human PBMC's as the initial cell based functional assay in the screening cascade and as a marker of activity in a human system.

The cascade begins with the synthesis of compounds from a diverse library of structural templates. More details on this will be outlined later in the text though the synthesis details of these compounds are not covered in this thesis. All compounds made were tested in a PDE4 enzyme activity assay and if they had an IC₅₀ in this system of 10 μ M or less they were progressed further. The PDE4 assay was a high-throughput version of that described by Thompson in 1974.⁴⁷ A level of potency of 10 μ M in the PDE4 assay was felt to be sufficient to progress compounds into further screening for structure activity relationship (SAR) purposes but insufficient for selection of a compound for development where potencies of low micromolar to nanomolar were considered more appropriate to allow for less than 100% bioavailability.

The initial source of PDE4 enzyme used in the screening assay was from lysed guinea pig macrophages. This was minimally treated enzyme to give a more accurate representation of PDE4 enzyme in the low affinity state. Later on PDE4 was purified from the human monocyte cell line U937's using anion exchange chromatography and validated using a number of standards across a range of structural classes for correlation between activity against this enzyme source and that of lysed guinea pig macrophage derived enzyme. An example of the level of correlation can be seen when comparing data from publications 2 and 4. The IC₅₀ for rolipram against macrophage PDE4 was 2.42 μ M (publication 2) and against U937 purified PDE4 it was 3.5 μ M (publication 4). The transition to a purified enzyme source was necessary to cope with compound throughput.

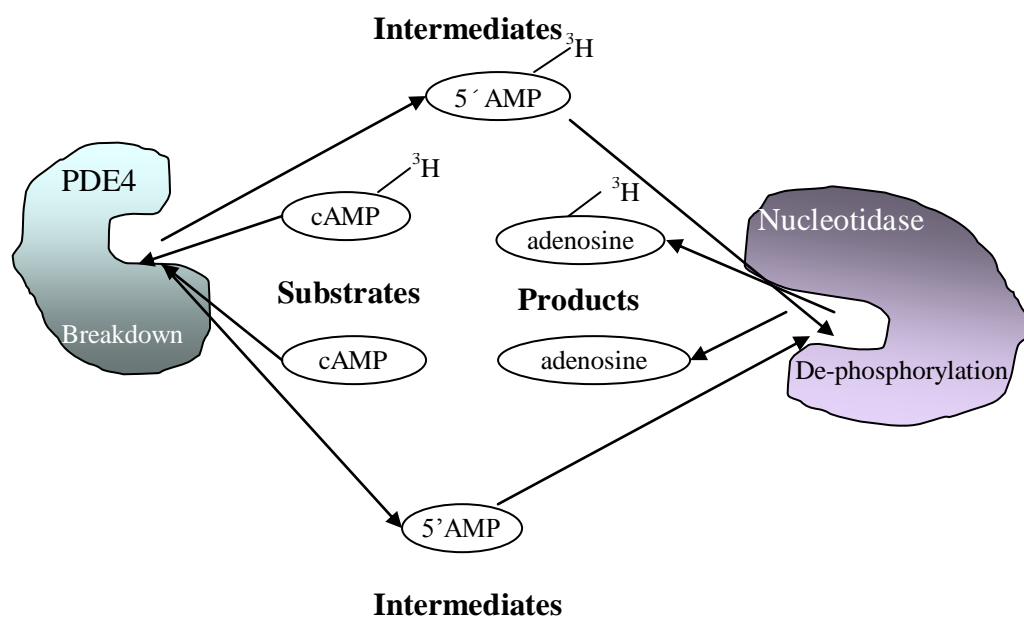

Figure 6. Diagrammatic representation of PDE4 enzyme assay.

The PDE4 assay (Figure 6) involved the initial breakdown of cAMP to 5'AMP by PDE4 assayed as 'hot' [^3H]-cAMP competing with 'cold' cAMP, then subsequent breakdown of [^3H]-5'AMP or 5'AMP to [^3H]-adenosine or adenosine by nucleotidase from snake venom (Figure 6). The reagents were incubated for 30 mins at 30°C and the reaction terminated by the addition of anion exchange resin. The plates were then centrifuged or filtered, the supernatants collected and the amount of radiolabelled adenosine present counted. The assay was validated with the standard PDE4 inhibitors included in this publication and the results checked against published data.

The next assay in the cascade was the rolipram binding assay which was used as a selection process to avoid the clinically observed nausea and emesis side effects of PDE4 inhibitors. The assay used was based, on a method by Schnieder³² *et al* in which, competitive binding of [^3H]-rolipram to rat brain was studied. The mechanisms by which PDE4 inhibitors induce emesis are poorly understood, but based on animal studies some correlation with these effects and activity at the rolipram binding site had been observed (see Chapter 1, section 1.2.1, Table 3). The rolipram binding assay utilised a rat brain preparation as the source of the high affinity PDE4 catalytic site and [^3H] – rolipram as the binding ligand. The assay involved competitive binding between [^3H] – rolipram and added compounds and was automated using a literature based method³² to allow the use of 96-well GF/B Millipore microtitre plates, robotic pipetting and counting on a Packard Top Count scintillation counter. The reagents were incubated for 1 hr at 22°C after which the reaction was terminated via filtration. The assay was validated with the standard PDE4 inhibitors included in publication 2 and the results checked against published data.

Once an IC_{50} was obtained in the RBA it was compared with the IC_{50} obtained in the PDE assay and a ratio was calculated. A value for this ratio of 10 or less showed a selectivity of LARBS over HARBS, or efficacy over emesis and therefore led to the molecule being progressed into PDE selectivity assays for PDEs 1, 2, 3 and 5.

Selectivity for PDE4 over the other PDE subtypes was important to avoid side effects, which could occur via interaction with other PDEs such as the cardiovascular side effects due to PDE3 inhibition (PDE3 is found in heart and vascular smooth muscle – see Table 1).

Ten fold or greater selectivity across the PDE isoenzymes meant that the molecules moved forward for testing in the final *in vitro* system, measuring the effect of inhibitors on LPS induced TNF α release from human PBMCs. This assay, though still *in vitro*, gave a functional readout of PDE4 inhibitory activity in cells derived from human blood, peripheral blood mononuclear cells separated on a Percoll gradient from buffy coats (buffy coats are the fraction of anticoagulated blood sample after density gradient centrifugation containing white blood cells and platelets). Inhibition of TNF α release represents a downstream effect of cAMP elevation. Inhibition of TNF α was selected, as mechanistic studies in the scientific literature indicated that TNF α appeared to be an important cytokine in the functional activity of the PDE4 inhibitors. This pro-inflammatory cytokine is released early in the inflammatory cascade in asthma on allergen stimulation of macrophages.²¹

A series of other cytokines were also examined for effects on their release though only for PDE4 inhibitors which had successfully progressed through the screening cascade (D 4418 (Poster 4) and SCH 351591 (Publication 11)). The cytokines measured were IL-5 and IL-12 from human PBMCs. Their release was stimulated by, PMA/PHA, and *Staphylococcus Aureus*, respectively. The release of IL-5 was attenuated by, D 4418 and SCH 351591, and IL-12 by SCH351591 only. These pro-inflammatory cytokines have clear roles in human disease and have been specifically implicated to have a role in asthma.³

An IC₅₀ in the human PBMC TNF α release assay of 10 μ M or less accompanied by all of the other *in vitro* criteria meant that the molecule could now progress into an *in vivo* system.

The first *in vivo* system in the cascade was the guinea pig skin eosinophilia model. (see publication 2 for method). The ability of a compound to inhibit inflammogen driven eosinophil infiltration into the skin at 10 mg/kg or less was observed to represent anti-inflammatory activity in a whole animal system. This efficacy in itself was interesting, but only if it was at a dose, which differentiated from its side effect dose.

As outlined in the introduction, the primary side effect of PDE4 inhibitors is emesis (see publication 11 for method). The species chosen here for initial emesis testing was the ferret. The ferret has been used for emesis research since 1982⁷³ when it was observed to vomit in response to cisplatin. The ferret was preferable as an initial screen from both an ethical and compound requirement perspective. If emesis was observed at the efficacy dose of 10 mg/kg the compound was not progressed further. If a higher dose was required however to induce emesis a therapeutic window of efficacy over emesis could be established and the compound would be investigated further.

At this later stage the ovalbumin sensitised guinea pig lung eosinophilia model was used to study the effect of oral dosing of compounds on pulmonary cell infiltration

due to ovalbumin challenge (see publication 11 for method). An efficacious dose of 10 mg/kg was again required in this system. Two models were used for the lung work. Early stage compounds were looked at for their ability to inhibit inflammatory cell influx into the airways produced by ovalbumin challenge to conscious guinea pigs only. Later compounds were also compared against other clinically relevant parameters namely airway hyper-reactivity and early and late-phase bronchoconstriction⁷⁸.

The more complex model was chosen as a closer representation of the complex pharmacological nature of asthma. In asthmatic patients allergen exposure commonly leads to reproducible patterns of respiratory responses often involving an early and a late phase response. In the early asthmatic response (EAR) maximal airway narrowing occurs within 15–30 minutes of allergen exposure and returns to baseline within 1–2 hours. Approximately 60% of subjects also develop a second, late asthmatic response (LAR) approximately 3–5 hours after allergen exposure, which is maximal at 6–12 hours, and may persist for up to 24 hours. These responses are thought to reflect different pharmacologies. The evidence for this can be found in the observation that the EAR is attenuated by, β -agonists and mast cell stabilisers whilst the LAR is not. Steroids are effective against the LAR when given before allergen provocation or chronically dosed. These findings have led to the belief that the EAR is dependent primarily on the release of mediators from airway mast cells, leading to bronchoconstriction and airway oedema, whilst the LAR requires an infiltration of activated inflammatory cells, particularly lymphocytes and eosinophils, into the asthmatic airways leading to bronchoconstriction and over time chronic inflammation of the respiratory tract. The airways also become hyperreactive to a range of spasmogens including adenosine, cAMP and the thromboxane mimetic U46619. The model used recorded EAR and LAR to chronic ovalbumin challenge in conscious sensitized guinea pigs over 24hrs, hyper-reactivity of the airways to U46619 and inflammatory cell influx via bronchial lavage. Graphical representation of these three features is given on the section describing the poster in Chapter 4 showing the effect of the first development candidate, D 4418.

Method⁷⁸

Male Dunkin-Hartley guinea pigs were sensitised to ovalbumin (10 μ g) 14 days before use. Drugs were dosed 30 minutes before and 6 hours after ovalbumin challenge. Sensitised animals received a 10 minute inhalation exposure of either saline or a 0.5% solution of ovalbumin in saline after an intra-peritoneal dose of mepyramine maleate (3mg/kg to protect against fatal anaphalaxis). A Wright nebulizer was used to deliver the antigen or vehicle into a sealed Perspex chamber. Any animal appearing to be in respiratory distress during exposure was immediately removed and the exposure considered complete. To study airway reactivity a further challenge for 60s with a threshold dose of the thromboxane mimetic U46619 was performed at 17-24 hours post ovalbumin challenge. Respiratory function was measured using whole body plethysmography of the conscious guinea pigs and recorded as specific airway conductance (sG_{aw}). A minimum of 5 breaths, were measured for each animal at each time point. Broncho-alveolar lavage was performed on all animals within 30 minutes of the U46619 challenge. Total cell counts were performed using a Neubauer haemocytometer. Differential cell counts on a minimum of 500 cells were then performed using Giemsa/May-Grunwald staining.

Compounds with activity in the lung eosinophilia model at 10 mg/kg were then re-evaluated for emesis in the dog, which is a more sensitive species than the ferret to emetic stimuli. Alongside these latter tests pharmacokinetic measurements in guinea pig, ferret and dog were also measured to allow correlation of observed activity in both efficacy and side effect models and plasma exposure.

The classes of compound examined as part of this PDE4 programme were: xanthines, benzofurans, sulfonamides, quinolines and quinolones selected due to their structural similarity to known PDE4 inhibitors or via high throughput screening.

Success in all the criteria set out in the screening cascade would culminate in a compound entering non-clinical development (safety pharmacology, toxicology, ADME) followed by clinical development. The screening cascade had two development candidate successes both of which progressed into clinical trials, D 4418 (poster number 4) and SCH 351591 (publications 10 and 11).

Chapter 3

3. Results

3.1 Publication 2. *A comparison of the inhibitory activity of PDE4 inhibitors on leukocyte PDE4 activity in vitro and eosinophil trafficking in vivo.*

In publication 2, compounds were tested in the primary *in vitro* assays from the screening cascade and the initial *in vivo* assay; PDE4 inhibitory activity (selectivity against other PDE subtypes was not tested but was available from the literature), rolipram binding; LPS induced TNF α release from human PBMCs, and the guinea pig skin eosinophilia model.

The molecules tested in this publication were competitor compounds of interest at the time, namely RP 73401⁴⁵ also known as piclamilast (3-cyclopentyloxy-*N*-(3, 5-dichloro-4-pyridyl)-4-methoxybenzamide), CDP 840⁴⁶ (R-(+)-4-[2-(3-cyclopentoxy-4-methoxyphenyl)-2-phenylethyl] pyridine) from Celltech, LAS 31025⁴⁹ from Laboratorios Almirall and SB 207499⁵⁰ also known as Ariflo ([*c*-4-cyano-4-(3-cyclopentyloxy-4-methoxy-phenyl)-*r*-1-cyclohexanecarboxylic acid]) from Smithkline Beecham (Figure 7). More information on these agents is provided in Chapter 6.

RP 73401 is a very potent and selective PDE4 inhibitor which reached Phase II clinical trials for asthma via the inhaled route and rheumatoid arthritis at low doses orally t.i.d. The dosing regimes used reflect the issues the compound displayed in terms of nausea and vomiting but also its low oral bioavailability due to first pass metabolism which was possible to avoid by dosing via inhalation. The drug was under development via the inhaled route but was discontinued as it was found to cause tumours of the nasal olfactory regions in a two year rat inhalation carcinogenicity study.

CDP 840 is less potent than RP 73401 but does have good selectivity for PDE4 over the other isoenzymes. CDP 840 completed a Phase IIa clinical trial for asthma via the oral route where it did show statistically significant inhibition when compared to placebo of an allergic response in asthma patients without significant nausea and emesis side effects. This was a breakthrough in the area of PDE4 research.

LAS 31025 is a PDE4 inhibitor from the xanthine class of compounds to which theophylline belongs. LAS 31025 is more potent against PDE4 than theophylline but still has its selectivity issues against PDE3 and adenosine receptors (xanthines will be discussed further later on review of publication 4). LAS 31025 reached Phase III clinical trials for asthma and COPD.

SB 207499 is a PDE4 inhibitor which, was synthesised to show selectivity for the low affinity binding site (LARBS) over the high affinity binding site (HARBS) to produce a drug with an improved therapeutic index. SB 207499 had similar potency to rolipram against PDE4 (LARBS) but much reduced activity for the rolipram binding site (HARBS) and good selectivity over the other isoenzymes. SB 207499 reached

phase III trials for asthma and COPD (a more complete review of this molecule is given in Chapters 1 and 6).

The PDE4 enzyme assays used in publication 2 involved the use of cell lysates from guinea pig eosinophils, guinea pig neutrophils, guinea pig macrophages and human neutrophils. Cell lysates were generated using a mild process to ensure the LARBS site was being investigated and not the HARBS.⁵¹ Guinea pig macrophages were used as this was the initial source of PDE4 enzyme for the screening cascade *in vitro* PDE4 assay. Guinea pig eosinophils were studied to correlate enzyme activity in eosinophils with *in vivo* effects on eosinophil trafficking and neutrophils as a comparison with human neutrophil PDE4 activity. Human neutrophils were used as neither eosinophils nor macrophages could be isolated in sufficient quantities from human sources (human PBMCs) and a guinea pig to man translational comparison was desirable to allow correlation of inhibition of human PDE4 enzyme activity with the inhibition of TNF α release measured from human PBMCs.

The rolipram binding ratio was calculated as the compounds IC₅₀ in the guinea pig macrophage PDE4 assay divided by the IC₅₀ in the rolipram binding assay (RBA). As it was more favourable to have compounds with greater potency at the PDE4 site than the rolipram binding site (Chapter 1 section 1.2.1), a low value for this ratio was more favourable than a high one. The resulting ratios for the standards were used as starting points to help in the evaluation of subsequent compounds.

Rolipram has a long history of causing emesis as does RP 73401 having ED₅₀'s in *Suncus murinus* of 0.16 mg/kg, i.p. and 1.8 mg/kg, i.p., respectively.²⁷ The ratio for rolipram reflects this poor therapeutic window (48.4). This is not the case for RP 73401 which has a ratio of 1.57 however oral bioavailability is an issue for this drug which make the translation from *in vitro* into *in vivo* difficult. The pharmacokinetics of RP 73401 are reviewed in the summary of publication 6. LAS 31025 has been credited with a lower incidence of emesis than rolipram in the dog with a 10-fold superior therapeutic window (IDDB3) and this is in line with its improved ratio over that of rolipram (Table 5).

Table 5. *Ratio of the IC₅₀ in the PDE4 enzyme assay to the IC₅₀ in the rolipram binding assay for the PDE4 inhibitors used as standards to validate this PDE4 inhibitor screening cascade.*

Standard	PDE4 IC ₅₀ (μ M)	RBA IC ₅₀ (μ M)	PDE4:RBA
Rolipram	4.55 (8)	0.05 (>6)	48.4
RP 73401	0.002 (6)	0.003 (>6)	0.67
LAS 31025	9.01 (5)	0.75 (>6)	12
SB 207499	0.21 (6)	0.07 (>6)	3.00
CDP 840	0.36 (6)	0.25 (>6)	1.44

PDE4 from guinea pig macrophages
 RBA performed as a rat brain, binding assay
 The number of experiments is given in parenthesis
 Data are expressed as the mean

CDP 840 and SB 207499 showed greatly improved ratios, 3.28 and 2.68 respectively reflecting the success they achieved in entering and completing clinical studies with reduced emesis and the side effects of nausea.

No significant correlation was seen in this study between the *in vitro* activity of the PDE4 inhibitors (PDE4 enzyme inhibition, rolipram binding assay activity) and eosinophil trafficking in the guinea pig skin or between potency against human PDE4 enzyme and attenuation of TNF α release from human PBMC's. This lack of correlation may be explained by the fact that only a small number of compounds from diverse chemical classes were evaluated in this study.

Consistent blocking of ^{111}In -eosinophil recruitment into sites of allergic and mediator induced inflammation in guinea pig skin and of TNF α release was, however, found for all of the PDE inhibitors tested regardless of structural class thus validating the model for use in the screening cascade.

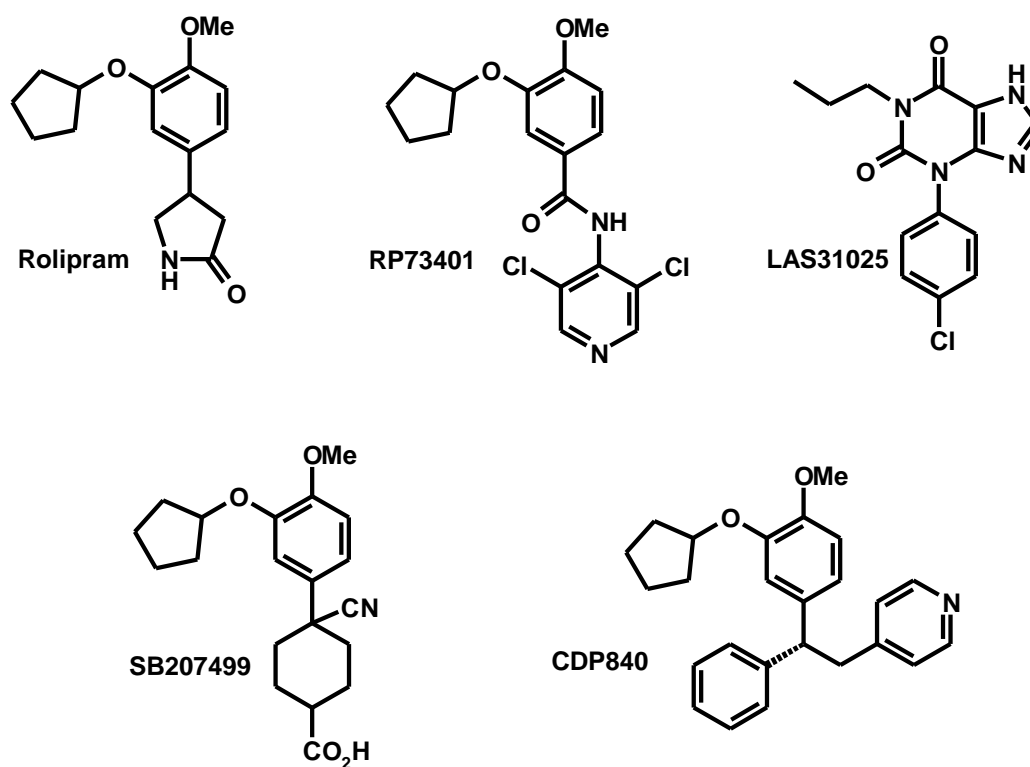

Figure 7. Structures of the PDE4 inhibitors used as standards to validate the PDE4 inhibitor screening cascade.

3.2 Publication 3. *PDE4 inhibitors: new xanthine analogues.*

Since the early observation in asthmatics²³ of a bronchodilator effect due to drinking coffee on an empty stomach, caffeine and the chemical class to which it belongs, the xanthines have been of interest in respiratory disease. The xanthines are weak PDE inhibitors and probably the most well known from this class is theophylline. Theophylline⁵² was first used in asthma in 1922 where Hirsch described its bronchodilator effects in three asthma patients. The limitations of the use of theophylline are its side effects which include nausea, headache and seizures at high doses. These side effects alongside its bronchodilator effects are probably due to inhibitory effects against PDE's 3 and 4 and cross reactivity with the adenosine receptors. Theophylline also has a short duration of action which led to the formulation of slow-release forms of the drug. As a safe and effective treatment for asthma theophylline has therefore significant scope for improvement. As mentioned in the introduction, LAS 31025 is a xanthine which had successfully reached late-phase clinical trials.

For the xanthines studied in publication 3, theophylline was the structural starting point. The clinical history with theophylline shows a high incidence of nausea and emesis which is thought to correlate not only with PDE inhibitory activity but also with its activity against adenosine receptors. This potential 'off-target' activity was an added complication for this class of molecule (LAS 31025 also adenosine receptor binding activity) and it was therefore necessary when testing the xanthines to assess adenosine activity in receptor binding assays (data not shown) together with the initial *in vitro* screens. This enabled the exclusion of compounds with activity against these receptors. When testing theophylline in the PDE4 and RBA assays weak affinity was found for both sites; 39% inhibition at 200 μM and 27% inhibition at 100 μM , respectively. The initial objective was therefore to produce compounds with improved potency for PDE4 whilst maintaining the weak affinity for RBA. This was achieved early on with compounds demonstrating low micromolar activity. This initial improvement was, however, coupled with increased potency in the RBA assay. Additional rounds of synthesis and testing led to a clear structure activity (SAR) relationship enabling the selection of compounds with selectivity for PDE4 over RBA. In addition to the SAR data, selectivity for PDE4 over PDE3 was also factored in to avoid the cardiovascular side effects observed with theophylline. Compounds with much improved potency and selectivity for PDE4 and with improved PDE4:RBA ratios, not only over theophylline but also over a key competitor xanthine at the time, LAS 31025 were generated. The lead molecule with the most favourable PDE4:RBA ratio from this series was identified as 3c (Table 6).

Table 6. *Ratio of the IC_{50} in the PDE4 enzyme assay to the IC_{50} in the rolipram binding assay for LAS 31025 and the lead xanthine (from publication 3).*

Standard	PDE4 IC_{50} (μM)	RBA IC_{50} (μM)	PDE4:RBA
LAS 31025	9.01	0.75	12
Lead xanthine 3c	4.2	1.02	4.1

All results are the mean of at least 3 determinations run in triplicate

PDE4 derived from guinea pig macrophages

RBA performed as a rat brain, binding assay

3c was selected for *in vivo* evaluation in the guinea pig skin eosinophilia model where it showed efficacy against eosinophil trafficking induced by sub-cutaneous arachadonic acid (AA), PAF, zymosan activated plasma (ZAP) and a passive cutaneous anaphalaxis reaction (PCA) at 5 mg/kg *via* the oral route, demonstrating not only efficacy but also oral bioavailability. The compound was also tested in the lung eosinophilia model where it had an EC₅₀ of approximately 10 mg/kg, p.o. No nausea or emesis was observed for this compound in the ferret when dosed at 10 mg/kg showing the compound to have a therapeutic window for efficacy over emesis. The structure of this compound is shown in Figure 8 as 3c.

Having carried out some SAR and selected a suitable compound, work ceased on the xanthines to allow exploration of other structural classes as outlined in the proceeding publications.

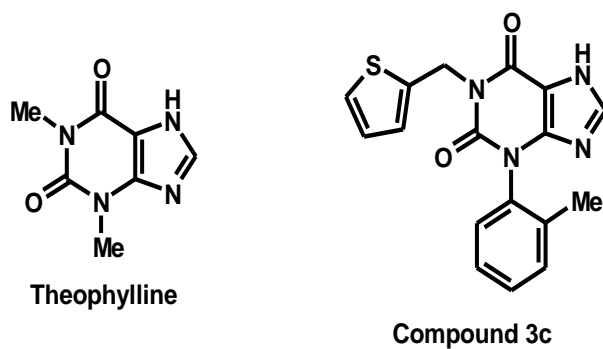

Figure 8. Structures of theophylline and the lead compound (3c) from publication 4.

3.3 Publication 4. *Aryl sulfonamides as selective PDE4 inhibitors.*

The aryl sulphonamides series employed rolipram as their structural template. As has already been mentioned the PDE4/RBA ratio for rolipram is very high giving a value, in this publication where U937 cells are used as the enzyme source of 175 (PDE4, IC₅₀ 3.5 μM). Introducing structural modifications however led to a compound with activity against PDE4 of 6 μM, similar to that of rolipram but with rolipram binding activity of only 12% inhibition at 10 μM, resulting in a PDE:RBA ratio of <0.6; a much improved relationship between HARBS and LARBS activity. In order to establish if this improvement in ratio would translate into an improvement in therapeutic window, the novel compound was tested against rolipram in the skin eosinophilia model and the ferret emesis model. In the ferret, emesis and CNS side effects (mouth scratching, salivation, and head burrowing - positive correlates of nausea) were observed. The results are shown in Table 7.

Table 7. *Guinea pig eosinophilia efficacious doses, ferret side effect doses and calculated therapeutic indices for rolipram and the lead aryl sulphonamide (from publication 4).*

Compound	Guinea pig eosinophilia Efficacy (mg/kg, i.p.)	Ferret Emesis (mg/kg, i.p.)	Ferret CNS side effects (mg/kg, i.p.)	TI Efficacy vs emesis
Rolipram	5 ¹	3	0.1	<1
Aryl sulphonamide Compound 20	5	Clean 10	Clean 10	>2

TI – therapeutic index; Guinea pig eosinophilia was performed in a minimum of 4 animals
Ferret emesis was performed in 4 animals

A clear improvement in therapeutic index was found for compound 20 (Figure 9) when comparing the compound (dosed via the i.p. route) for efficacy in the guinea pig skin eosinophilia model against both nausea/emesis and CNS side effects in the ferret for the novel compound over rolipram.

As with the xanthines, a lead compound was selected and then no further work was conducted on this class of compounds.

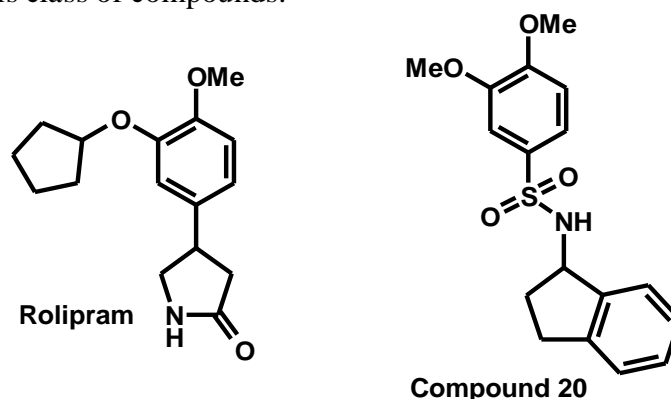

Figure 9. *Structures of rolipram and the lead aryl sulphonamide (compound 20) from publication 4.*

3.4 Publication 5. *Synthesis and evaluation of a novel series of phosphodiesterase IV inhibitors: a potential treatment for asthma.*

The quinolones, the structural class outlined in publication 5, were selected following a high-throughput screening (HTS) campaign against the PDE4 enzyme. HTS involves the large-scale screening of molecules not previously shown to be active against the chosen target. The approach allows the introduction of structural diversity usually creating a stronger intellectual property position.

After the initial hit generated via high throughput screening of in-house compounds SAR was conducted, as outlined in publication 5, and resulted in a lead molecule, 7g (Figure 5) with an IC₅₀ of 7 µM against PDE4 and only 8% binding at 10 µM against rolipram binding leading to a PDE4:RBA of <0.7. *In vivo* testing of this compound showed selectivity for efficacy in the guinea pig skin eosinophilia model over CNS effects in the ferret (Table 8) with efficacy found at 10 mg/kg and no emesis at 20mg/kg via the i.p. dosing route.

Table 8. *Guinea pig skin eosinophilia efficacious doses, ferret side effect doses and calculated therapeutic indices for rolipram and the lead quinolone (from publication 5).*

Compound	Guinea pig skin eosinophilia Efficacy (mg/kg, p.o.)	Ferret Emesis (mg/kg, p.o.)	Ferret CNS side effects (mg/kg, p.o.)	TI Efficacy vs emesis
Rolipram	0.5	0.3	0.3	<1
Quinolone Compound 7g	10	Clean 20	Clean 20	>2

TI – therapeutic index

Guinea pig skin eosinophilia was performed in a minimum of 4 animals

Ferret emesis was performed in 4 animals

Though this class of compounds offered an advantage from an intellectual property perspective they were not selective against PDE3. It was initially thought that this may have been an interesting activity for compounds to be used for the treatment of respiratory disease due to the resulting bronchodilator effects. The accompanying cardiovascular effects (Cilostazol⁵³ is a PDE3 inhibitor used in intermittent claudication due to its effects on blood clotting and artery dilatation) which these inhibitors also possess, however, due to the distribution of PDE3 in heart, platelets and vascular smooth muscle proved too risky and further work on the quinolones was abandoned.

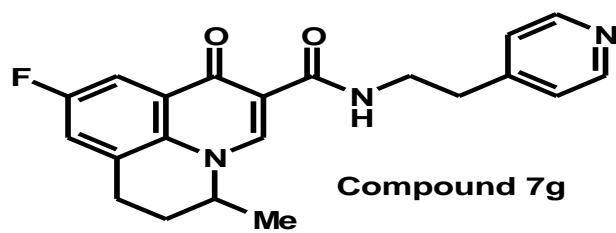

Compound 7g

Figure 10. Structure of the lead quinolone (7g) (from publication 5).

3.5 Publication 6. *7-Methoxybenzofuran-4-carboxamides as PDE4 inhibitors: a potential treatment for asthma.*

The benzofuran work reported in publication 6 was based on the structure of RP 73401 the Rhone Poulenc Rorer compound previously mentioned in this thesis. RP 73401 is structurally similar to rolipram but the pyrrolidinone moiety is replaced with 3,5-dichloropyridyl-4-carboxamide. The chemistry performed involved the retention of the 3,5-dichloropyridyl-4-carboxamide but involved cyclisation onto one of the phenolic oxygens creating a benzofuran group. This modification resulted in compounds with significantly greater potency against PDE4 enzyme and good selectivity against PDE3 and RBA (Table 9). The lead compound, 3a was more potent against PDE4 and more selective for this activity over HARBS than both rolipram and RP 73401.

Table 9. *Ratio of the IC₅₀ in the PDE4 enzyme assay, to the IC₅₀ in the rolipram binding assay and PDE 3 data for Rolipram and the lead benzofuran (from publication 6).*

Standard	PDE4 IC ₅₀ (μ M)	RBA IC ₅₀ (μ M)	PDE4:RBA	PDE3 % inhibition (20 μ M)
Rolipram	3.5	0.02	175	27
Lead benzofuran 3a	0.0016	0.0434	0.037	32
RP 73401*	0.005	0.003	1.57	NT

PDE4 purified from U937 cells

RBA performed as a rat brain, binding assay

All results are the mean of at least 3 determinations run in triplicate

*data from publication 2

NT not tested

The PDE4 catalytic potency also translated into a more potent *in vivo* activity in the skin eosinophilia model with an effective dose of 0.5 mg/kg (Table 10). The prediction that compounds showing selectivity of LARBS vs HARBS would result in an improved therapeutic index was maintained in this series with the lead compound, 3a (Figure 11) showing no side effects in the ferret model at 10 mg/kg p.o. and therefore having a therapeutic index of at least 20 (Table 10).

Table 10. *Guinea pig eosinophilia efficacious doses, ferret side effect doses and calculated therapeutic indices for rolipram and the lead methoxybenzofuran-4-carboxamide (from publication 6).*

Compound	Guinea pig Efficacy (skin eosinophilia) (mg/kg, p.o.)	Ferret Emesis (mg/kg, p.o.)	Ferret CNS side effects (mg/kg, p.o.)	TI Efficacy vs emesis
Lead compound (3a)	0.5	Clean 10	Clean 10	>20

TI – therapeutic index

Guinea pig eosinophilia was performed in a minimum of 4 animals

Ferret emesis was performed in 4 animals

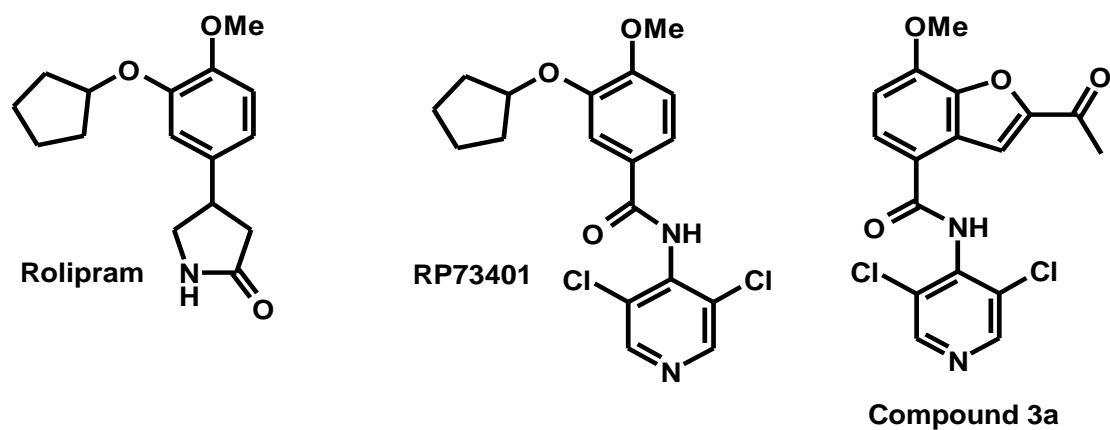

Figure 11. *Chemical structures of rolipram, RP 73401 and the lead 7-methoxybenzofuran-4-carboxamide (3a) (from publication 6).*

Due to this significant advance in potency and selectivity further modifications were made in this series of compounds some of which are outlined in publication 7.

3.6 Publication 7. *7-Methoxyfuro[2,3-c]pyridine-4-carboxamides as PDE4 inhibitors: a potential treatment for asthma.*

In the novel series of compounds reported in publication 7, 7-methoxybenzofuran was replaced with 7-methoxyfuro[2,3-c]pyridine. The incorporation of a nitrogen moiety was undertaken in order to try and improve the pharmacokinetic properties of the compounds by increasing their solubility.

The benzofurans in common with RP 73401 suffered from extensive first pass metabolism in the liver and amide hydrolysis resulting in very poor pharmacokinetics. This was found to be due to metabolism by the CYP metabolic enzyme, CYP2B6⁷² with the site of hydroxylation only occurring at the 3-position of the cyclopentyl ring. The group at Rhone Poulenc Rorer had examined the effect of benzofuran substitution⁵⁴ with moderate improvements in bioavailability.

In a direct structural comparison of the 7-methoxyfuro[2,3-c]pyridine and the 7-methoxybenzofuran a pharmacokinetics study was performed via oral dosing in the guinea pig (Table 11) These results represented a marked improvement of the 7-methoxyfuro[2,3-c]pyridine over the 7-methoxybenzofuran in terms of C_{max} and AUC (the 7-methoxyfuro[2,3-c]pyridine had a bioavailability of 54%).

Table 11. *Pharmacokinetic parameters after oral dosing in guinea pig of the lead 7-methoxyfuro[2,3-c]pyridine-4-carboxamides (from publication 7).*

Dose (3mg/kg, p.o.)	C _{max} (ng/mL)	AUC (ng.h/mL)
Compound 8a	1411	4942
2,ethyl benzofuran equivalent of 8a	311	1394

C_{max} maximum concentration of drug in plasma

AUC_{0-t} area under the plasma drug concentration curve calculated from before drug is dose (0) to the last time point (t).

Pharmacokinetics were performed in 3 animals

The compound tested for pharmacokinetic parameters in the guinea pig, 8a (Figure 12) had potent and selective *in vitro* pharmacology (Table 12).

Table 12. *Ratio of the IC₅₀ in the PDE4 enzyme assay, to the IC₅₀ in the rolipram binding assay and PDE 3 data for rolipram and the lead 7-methoxyfuro[2,3-c]pyridine-4-carboxamides (from publication 7).*

Standard	PDE4 IC ₅₀ (μM)	RBA IC ₅₀ (μM)	PDE4:RBA	PDE3 % inhibition (20μM)
Rolipram	3.5	0.02	175	27
Compound 8a	0.0014	0.084	0.016	32
RP 73401*	0.005	0.003	1.57	NT

PDE4 enzyme was derived from U937 cells

RBA performed as a rat brain, binding assay

All results are the mean of at least 3 determinations run in triplicate

*data from publication 2

NT not tested

The compound was also efficacious at 10 mg/kg in the guinea pig lung eosinophilia model where it showed 40% inhibition of lung eosinophil infiltration. Unfortunately emesis (data not published) was observed in the ferret at the same dose preventing the compound from being exploited further.

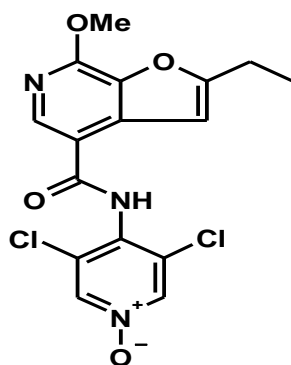

Compound 8a

Figure 12. *Chemical structure of the lead 7-methoxyfuro[2,3-c]pyridine-4-carboxamide (8a) (from publication 7).*

3.7 Publication 8. *8-Methoxyquinoline-5-carboxamides as PDE4 inhibitors: a potential treatment for asthma*

The promising improvements in pharmacokinetics found in the molecules generated in publication 7 by the introduction of a nitrogen group led to the synthesis of the nitrogen containing quinolines in publication 8. The initial compound synthesized in this series was much less potent than molecules from publications 6 and 7 with an IC₅₀ of only 1.9 μM against PDE4. Further synthesis was able to generate a compound (3c) with improved potency and an excellent PDE4:RBA ratio (Table 13).

Table 13. *Ratio of the IC₅₀ in the PDE4 enzyme assay to the IC₅₀ in the rolipram binding assay and PDE 3 data for rolipram and the lead 8-methoxyquinoline-5-carboxamides (from publication 8).*

Standard	PDE4 IC ₅₀ (μM)	RBA IC ₅₀ (μM)	PDE4:RBA	PDE3 % inhibition (20μM)
Rolipram	3.5	0.02	175	27
Lead Quinoline, 3c (publication 8)	0.17	0.53	0.32	10

PDE4 enzyme purified from U937 cells

PDE3 purified from human platelets

RBA performed as a rat brain, binding assay

All results are the mean of at least 3 determinations run in triplicate

The predicted *in vitro* therapeutic window translated into *in vivo* selectivity for efficacy over emesis with compound 3c. Initial data from publication 8 are shown in Table 14.

Table 14. *Guinea pig eosinophilia efficacious doses, ferret side effect doses and calculated therapeutic indices for rolipram and the lead 8-methoxyquinoline-5-carboxamides (from publication 8).*

Compound	Guinea pig Efficacy (lung eosinophilia) (mg/kg, p.o.)	Ferret Emesis (mg/kg, p.o.)	Ferret CNS side effects (mg/kg, p.o.)	TI Efficacy vs emesis
Lead compound (3c)	30	Clean 60	Clean 60	>2

Guinea pig eosinophilia was performed in 8-10 animals

Ferret emesis was performed in 4 animals

Students t-test analysis was performed in the guinea pig eosinophilia model (data not shown) to test for significance.

TI – therapeutic index

The lead molecule, 3c, maintained good pharmacokinetic properties having a C_{max} of 473 ng/mL, an AUC of 925 ng h/mL and an oral bioavailability of 62% after dosing in the guinea pig at 5mg/kg p.o.

This molecule continued to be evaluated in the assays outlined in the screening cascade (Figure 5), met all of the criteria and was successfully nominated as a

development candidate to progress into non-clinical safety and clinical studies. Once nominated into development the compound was known as D 4418. The data generated for D4418 are given in the Poster outlined in the next section of this thesis.

3.8 Poster. D 4418 - A New PDE4 Inhibitor for the Treatment of Asthma

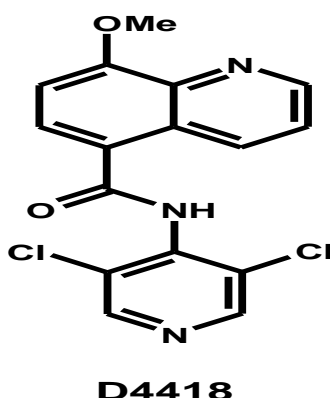

Figure 13. Schematic of the structure of D 4418.

After nomination, the discovery of D 4418 (Figure 13) was presented as a poster at the American Thoracic Society conference in San Diego in 1999.

In vitro

D 4418 had a very attractive *in vitro* profile (Table 15) with potent activity against PDE4 and in cytokine release assays, and excellent selectivity in for PDE4 over RBA, and PDE's 1, 2, 3 and 5. The similarity between the enzyme inhibition and functional cytokine release data show D4418 to be effective in terms of its cell penetration.

Table 15. *In vitro* profile for D4418.

	IC ₅₀ (nM)				% inhibition at 20μM			
	PDE4	RBA	TNF α	IL-5	PDE 1	PDE 2	PDE 3	PDE 5
D4418	170	530	160	500	31%	22%	10%	14%

PDE4 purified from U937 cells

PDE2, 3 and 5 were purified from human platelets

PDE1 was recombinant enzyme

All results are the mean of at least 3 determinations run in triplicate

IL-5 determinations were carried out in buffy coats stimulated with PHA and PMA

TNF α determinations were carried out in peripheral blood mononuclear cells derived from buffy coats stimulated with LPS (measured by ELISA)

In vivo

The ovalbumin sensitised guinea pig lung model of antigen, induced bronchoconstriction elicits both an early and late phase response in airway function. This model is a good representation of airway function in asthmatics. The early bronchoconstriction is mechanistically similar to an initial response to antigen exposure involving a mast cell driven histamine response whereas the late phase is more in keeping with subsequent antigen exposures which elicit inflammatory cell infiltration into the lungs which in the case of asthma are predominantly eosinophils and a bronchoconstriction caused by release of inflammatory mediators from these cells. D 4418 was seen to be effective in this model at 10 mg/kg, p.o. against both the

early and late phases. Clinically, bronchodilators such as beta₂-agonists are used to counter the early phase whereas steroids are required for an effect on the late phase. These results were encouraging in light of the vision that the PDE4 inhibitors would be able to treat the underlying inflammation in respiratory disease and prove to be steroid sparing. Other parameters were also measured in this model; namely inflammatory cell infiltration and airway hyper-reactivity in response to a thromboxane mimetic. D 4418 was effective against all of these parameters at 10 mg/kg, p.o. (Figures 14-16). The effect seen on the early phase was not significant at the 15 minute time point but AUC analysis of the 0-4 hour time points did show a clear effect for D4418 over vehicle. Statistical data are not given here and are no longer available to the author. Statistical analysis was however performed all results being compared by use of ANOVA with Neuman-Keuls test for multiple comparisons. Because of inter-subject variability for airway conductance measures (sGaw values), they are expressed as the % change from a baseline value of sGaw taken immediately before the start of the procedure. Absolute values of sGaw are taken for the baseline and the 15 min and 17 ± 24 h responses after ovalbumin challenge and 2min after U46619 challenge.

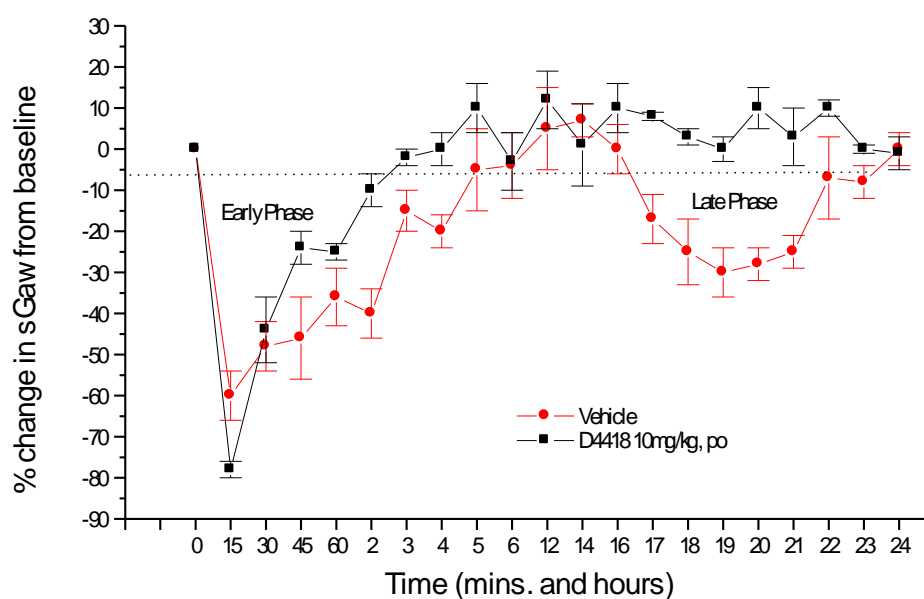

Effects on the airways response of vehicle (v) or D4418(λ) at 10 mg kg given orally at 30 min before and 6h after ovalbumin challenge. Mean responses (with vertical lines indicating s.e.mean) measured as the % change in sGaw (specific airway conductance) from baseline at regular intervals after the ovalbumin exposure (n=6 ± 11). Negative values represent bronchoconstriction.

Figure 14. Graphical representation of inhibition of antigen induced bronchoconstriction in the guinea pig by D 4418 at 10 mg/kg, p.o.

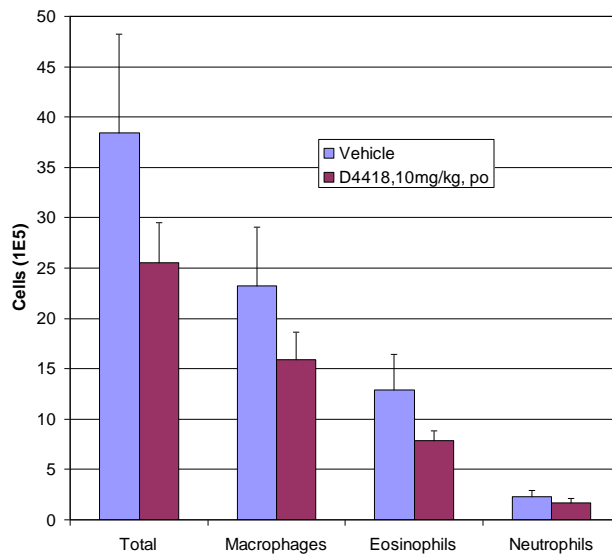

The effects of vehicle (v) or D4418 (v) at 10mg/kg, po, on leukocyte recovery from the airways after ovalbumin challenge. Vehicle or D4418 were administered 30min before and 6h after challenge. (n=5 ± 7). Values are mean cell counts (x10⁵ cells/ml). Analysis by ANOVA was performed followed by Neuman-Keuls test (data not shown).

Figure 15. Graphical representation of inhibition of antigen induced bronchoalveolar cell infiltration in the guinea pig by D 4418 at 10 mg/kg, p.o.

Airway Response to Inhaled U4419 24hrs after Ovalbumin Challenge

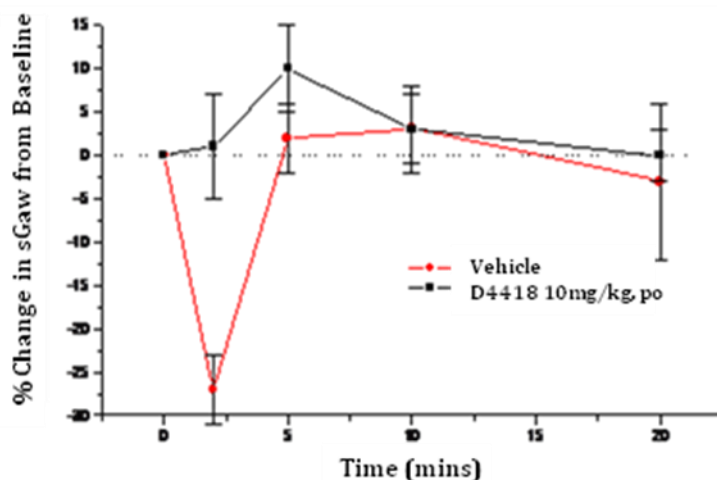

Responsiveness to inhaled U46619 (30ng/ml/1 60 s) 17 ± 24 h after ovalbumin challenge of sensitized guinea-pigs, and its modulation by vehicle (v) or D4418 (λ) given at 10mg/kg by double dosing at 30min before and 6h after ovalbumin challenge. Mean responses (with vertical lines showing s.e.mean) measured as the % change in sGaw from baseline at regular intervals after the U46619 exposure, are shown (n=5 ± 7). Negative values represent bronchoconstriction.

Figure 16. Graphical representation of the effect on airway response to inhaled U46619 24 hrs after ovalbumin challenge in the guinea pig of 10 mg/kg D 4418 p.o.

Pharmacokinetic studies in the guinea pig with D 4418 showed good exposure when dosed orally and *i.v.* with a bioavailability of 69% and a T_{max} via the oral route of approximately 1hour.

To assess the therapeutic window for this compound it was dosed to ferrets. The compound was clean (free of side effects) up to 100 mg/kg at which dose some retching was seen. This gave D4418 a therapeutic window of approximately 10 fold, though admittedly across different species.

D 4418 passed successfully through non-clinical safety and 28 day toxicology studies including *in vitro* genotoxicity (Ames and chromosome aberration studies) and *in vivo* dosing in rat and dogs where a no effect level was obtained at a dose sufficiently high enough to allow clinical studies.

In the Phase I clinical study to assess safety, tolerability and pharmacokinetics (Table 16) in healthy volunteers, D 4418 was given at a dose range of 5 mg to 200 mg. Plasma exposure was observed and even at the top dose no signs of vomiting were seen only mild side effects of headache, dizziness and nausea. *Ex-vivo* measurements of cAMP and $TNF\alpha$ were made in whole blood samples taken at a single time point, which gave some indication of pharmacodynamic activity for D4418. Sample numbers were, however, insufficient to allow statistical analysis (data not available).

Table 16. *Pharmacokinetic parameters for 200mg dose of D4418 in man.*

	C_{max} (ng/mL)	AUC (ng.h/mL)
D4418 200mg	1409	6782

C_{max} maximum concentration of drug in plasma

AUC_{0-t} area under the plasma drug concentration curve calculated from before drug is dose (0) to the last time point (t).

3.9 Publications 9 and 10. 8-Methoxyquinolines as PDE4 inhibitor.

D4418 did not proceed into further clinical trials but work did continue on the 8-methoxyquinoline chemical series and this is outlined in publications 9 and 10. The objective of the work was to obtain more potent compounds than D4418 against PDE4 enzyme activity and in *in vivo* efficacy models whilst maintaining good selectivity over the HARBS and the related nausea and emesis side effects.

The lead compound generated from this series of 8-methoxy-quinolines was approximately three times more potent against PDE4 than D 4418 with an IC_{50} of 51 nM and approximately ten times more potent against RBA with an IC_{50} of 77 nM. It did however have an improvement in oral bioavailability of approximately 10%, and was more potent in the guinea pig lung eosinophilia model showing oral efficacy at 3 mg/kg. Preliminary work in the ferret showed the compound to be clean at 6 mg/kg, p.o.

The lead compound outlined in publication 9 was SCH 365351 (Figure 17). In publication 10 it was shown that this compound, when dosed in rats, led to the formation of a metabolite which at time points greater than three hours was at higher levels than those of the parent SCH 365351. The metabolite was identified as the pyridine *N*-oxide (Figure 17) and a decision was made to explore the attributes of this compound and to generate SAR around other pyridine *N*-oxides of this type.

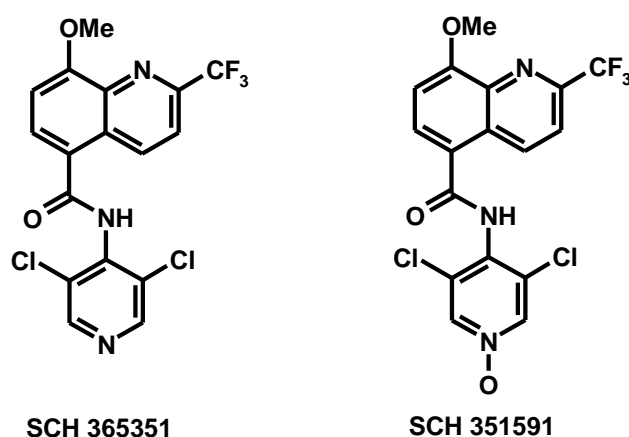

Figure 17. Schematic of the structures of SCH 365351 and its *N*-oxide metabolite: SCH 351591.

The most interesting compound explored was the *N*-oxide of SCH 365351 a molecule designated SCH 351591. The comparative IC_{50} 's of SCH 365351 and SCH 351591 against PDE4, SCH 351591 isozyme selectivity data and RBA data are given in Tables 17 and 18. SCH 351591 represented a significant improvement in RBA.

Table 17. PDE isozyme selectivity for SCH 351591.

	% inhibition at 10 μ M				
	PDE 1	PDE 2	PDE 3	PDE 5	PDE 7
SCH 351591	15%	0%	31%	5%	10%

PDE2, 3 and 5 were purified from human platelets

PDE1 was recombinant enzyme

PDE7 purified from HUT 78 cells

All results are the mean of at least 3 determinations run in triplicate

Table 18. PDE4 and RBA data for SCH 351591 and SCH365351.

	PDE 4 IC ₅₀ (nM)	RBA IC ₅₀ (nM)
SCH 365351	51	77
SCH 351591	60	150

RBA performed as a rat brain, binding assay

PDE4 purified from U937 cells

When examining the *in vivo* data to compare the pharmacokinetics of the two molecules in the guinea pig an improved profile for SCH 351591 over SCH 365351 was observed (Table 19).

Table 19. Pharmacokinetic parameters (C_{max} and AUC) for SCH 365351 and SCH 351591, its N-oxide metabolite, in the guinea pig.

Compound 3mg/kg po	C_{max} (ng/mL)	AUC _{0-t} (ng h/mL)
SCH 365351	380	1174
SCH 351591	1393	15757

Pharmacokinetic studies were performed in 3 animals

C_{max} maximum concentration of drug in plasma

AUC_{0-t} area under the plasma drug concentration curve calculated from before drug is dose (0) to the last time point (t).

These initial data on SCH 351591 led to a more detailed examination of this compound in a range of animal models. Although this publication covers some of this pharmacology a more detailed account is given in publication 11.

3.10 Publication 11. *Pharmacology of N-(3,5-dichloro-1-oxido-4-pyridinyl)-8-methoxy-2-(trifluoromethyl)-5-quinoline carboxamide (SCH351591), a novel, orally active phosphodiesterase 4 inhibitor*

Publication 11 outlines the pharmacological properties of SCH 351591. This package was put together to allow the nomination of this molecule into development.

Comparisons were made throughout the manuscript with the parent compound SCH 365351 in a number of models and with SB 207499 (Ariflo, Cilomilast) the most advanced PDE4 inhibitor at the time. A number of the key studies and comparative data are given below.

The allergic cymologous monkey model, which utilises naturally sensitised animals and involves eliciting bronchoconstriction via inhalation of *Ascaris suum*, was used as it was considered representative of human asthma being in primate and in naturally sensitised animals. In this model SCH 351591 showed inhibition of lung eosinophil infiltration when dosed orally at 3 mg/kg.

In order to provide a degree of translational data human tissue was used. Data for inhibition of cytokine release by SCH 351591 and SB 207499 from human PBMC's is given in Table 20. Another human tissue model used was passively sensitised isolated human bronchus to investigate the effects of SCH 351591 on anti-human IgE antibody induced contraction. The peak contraction was significantly reduced by SCH 351591 at 1 μ M an improved potency to that of aminophylline⁵⁵ a weak PDE4 inhibitor which is routinely recommended as a basic part of asthma emergency treatment. SB 207499 was not studied in this system.

Table 20. *Inhibition of cytokine release from human PBMC's by SCH 351159 and SB 207499.*

	Inhibition of cytokine release from human PCMC's (IC ₅₀ nM)		
	TNF α	IL-5	IL-12
SCH 351591	59 (22, 157) [4]	50 (80, 324) [6]	14 (2,86) [6]
SB 207499	106 (50, 225) [18]	170 [1]	60 (34, 108) [5]

All values are means with 95% confidence limits in parenthesis and number of experiments in brackets
TNF α and IL-12 determinations were carried out in peripheral blood mononuclear cells derived from buffy coats stimulated with LPS (measured by ELISA)
IL-5 was determined in buffy coats (measured by ELISA)

SCH 351591 significantly attenuated allergen-induced eosinophila and airway hyperreactivity in allergic guinea pigs at doses as low as 0.3 mg/kg, similar effects were seen with SCH 365351 though a 10-30 fold drop in potency was seen for SB 207499.

SCH 351591, given orally at a dose of 0.3 mg/kg, significantly suppressed hyperventilation induced bronchospasm (HIB) in the non-allergic guinea pig HIB model. This is a model of exercise induced asthma and involves increasing the respiratory rate of the animals over 10 mins after pre-dosing with drug. The effects of

the drugs on the peak increase in lung resistance due to hyperventilation are then recorded.

In the ferret emesis model the maximum non-emetic doses of SCH 351591 and SB 207499 were 5 and 1mg/kg respectively.

As a more accurate measure of therapeutic index plasma levels were determined for SCH 351591 and SB 207499 at the oral minimal efficacious doses (MEDs) in guinea pigs of 0.3 mg/kg and 3 mg/kg respectively and the oral maximum non-emetic doses (MND) in ferrets of 5 mg/kg and 1 mg/kg, respectively. The therapeutic indices determined when comparing C_{max} for SCH 351591 and SB 207499 were 15 and 5, respectively and for AUCs 16 and 4, respectively. SB 207499 in Phase 1 studies at the time had shown nausea and vomiting at doses of ≥ 15 mg.⁵⁶ The improved therapeutic index of SCH 351591 over SB 207499 was a strong indication that it would be possible to dose SCH 351591 at higher doses clinically than SB 207499 without evoking emesis.

The nomination of this drug into non-clinical studies marked the end of the Chiroscience/Schering Plough collaboration. The joint research committee considered SCH 351591 to exhibit a promising preclinical profile as a treatment for asthma and COPD.

The results of the non-clinical work and the additional chemistry carried out by Schering Plough following on from publication 11, is outlined in the future work section of this thesis.

Chapter 4

4. Additional work published on SCH 351591

4.1 Toxicology

It is unusual in the pharmaceutical industry to find reports of toxicology studies in the scientific literature. They are available in the public domain only in regulatory documentation (Summary Basis of Approval) used for clinical study approval and final drug registration. The toxicology group at Schering Plough, however, decided to publish their findings on SCH 351591 in the journal, *Toxicologic Pathology*.⁵⁷

The published toxicology study outlined the evaluation of SCH 351591 in a 3 month rising dose study in cynomolgous monkeys. The study involved 4 groups of 4 monkeys/sex receiving vehicle control or doses of 12, 24 or 48 mg/kg of SCH 351591 daily via the oral route. The doses were based on a proposed clinical dose of 5 mg/kg and were designed to give exposure multiples of 2, 4, and 8 times the human level. In earlier studies emesis had occurred at these test article concentrations so to be able to reach levels of 48 mg/kg/day dose escalation was required to induce tachyphylaxis to the emesis. This extended the dosing period out to 104 days.

During the course of the study there were 5 unscheduled deaths or sacrifices which were attributed to sepsis or intestinal findings including colitis. The colitis was suspected to be due to immunomodulation. Because of the additional findings of sepsis and given the immunomodulatory nature of SCH 351591, immune cell function was assessed in surviving animals of the low and mid dose groups. There were no meaningful findings from these studies only when looking at effects on leucocyte function and this was also reflected in lymphoid depletion of both T and B cells on immunohistochemical staining.

The most striking histopathological finding was arteriopathy affecting mainly the small arteries of the stomach and heart and medium sized arteries of the heart, kidneys, pancreas, gall bladder and salivary glands. The effect seemed to represent an ongoing process of degeneration and regeneration though this was difficult to firmly establish as only 2 time points, days 26 and 105 were taken. These findings are consistent with those reported for rolipram in the rat. In the rat study, rolipram was administered for up to 2 weeks and the animals were found to develop myocardial necrosis and arteritis/periarteritis of coronary, mesenteric and portal arteries as well as nonvascular lesions of the salivary glands and GI tract.⁵⁸

Although SCH 351591 entered Phase I clinical trials, these toxicological findings, because of the requirement for chronic therapy in the treatment of asthma and COPD and the lack of clinical biomarkers to monitor early vascular changes, stalled any further development of the drug.

The Schering Plough group also studied differential expression of PDE4 in different species⁵⁷ in an attempt to better predict the potential relative toxicity in man. They found mRNA levels for the different PDE4 isoenzymes to be significantly higher in

rats than man in toxicologically relevant tissues and this correlated with significantly higher enzyme activity levels in rat leucocytes. PDE4 activity levels in monkey leucocytes fell between those of rat and man.

The PDE4 inhibitor SB 207499⁶⁰ also showed incidences of arteritis in its toxicology studies in the rat. The additional worry was that the effect also had a very steep dose response relationship with no lesions being seen at a dose of 20 mg/kg where they were clearly evident at 30 mg/kg and at doses of 40 mg/kg or higher the compound was lethal. These effects led to poor safety margins when comparing AUC for plasma exposures in clinical studies with those at which arteritis was observed in the toxicological studies. The development of arteritis, was identified by the FDA (Food and Drug Administration) as a significant safety issue, requiring strict monitoring in PDE4 clinical trials. For SB 207499 Phase III trials this included daily monitoring of all gastrointestinal adverse events of concern, and vital signs in supine sitting and standing positions to alert physicians of any signs of bowel infarction. However due to the late introduction of this procedure into the trial only 9 subjects who received SB 207499 underwent colonoscopy therefore the FDA concluded that there was insufficient evidence to prove that the drug would not cause vasculitis. Glaxo SmithKline made the decision to halt the development of SB 207499 in January 2008 for COPD. The development of this compound for asthma had been discontinued in 2001(Investigational Drugs Database).

4.2 Additional Chemistry

Due to the vasculitis observed in the monkey toxicology study and the finding that SCH 351591 converted back to its more potent parent pyridine derivative SCH 365351 in rats, mice and monkeys the extent of which varied across the different species, Schering Plough decided to try and replace the dichloropyridine *N*-oxide moiety of SCH 351591.⁶¹

The screening cascade at this stage was modified to screen against PDE4B, which had been identified as the predominant subtype in inflammatory cells. PDEs 9, 10 and 11 were also included and the primary efficacy model was the rat LPS induced pulmonary inflammation model and efficacy was also monitored in the monkey.

The medicinal chemistry group at Schering Plough used a pharmacophore generated from the PDE4 crystal structure to make modifications around the SCH 351591 base structure to produce a quinolyl oxazole with an IC₅₀ against PDE4 of 19 nM, good selectivity over other PDE isoenzymes, efficacy in the rat pulmonary inflammation model at 3 mg/kg and no emesis observed at 30 mg/kg in the ferret representing a therapeutic window of >10.

Chapter 5

5. Discussion

5.1 Findings and Interpretations

The results presented in this thesis show that it is possible to use the series of experiments outlined in Chapter 2 to select compounds with a preferable therapeutic index of anti-inflammatory activity over emetic side effects in the chemical classes tested (xanthines, aryl sulphonamides, quinolones, 7-methoxybenzofuran-4-carboxamides, and 7-methoxyfuro[2,3-*c*]pyridine-4-carboxamides). In publication 3 where the xanthine series was studied, the molecule 3c was selected for its *in vitro* potency and selectivity for PDE4 catalytic activity over HARBS activity. The selectivity profile of 3c for these activities was superior to those of the marketed xanthine asthma drug, theophylline, and the xanthine PDE4 inhibitor, in clinical development at the time, LAS 31025. When tested *in vivo* the hypothesis that selectivity for PDE4 over HARBS would result in a favourable therapeutic index was confirmed as 3c showed selectivity for efficacy in the guinea pig skin eosinophilia model (activity seen at 5mg/kg, po) over emesis in the ferret (no effects at 10mg/kg, po), when dosed orally. Though the xanthines were interesting as a series due to the proven efficacy of theophylline in asthma and the early LAS 31025 clinical data no further work was carried out and 3c was not progressed into development. Both theophylline and LAS 31025 are PDE3 inhibitors and adenosine receptors antagonists. This off-target activity makes it difficult to assess to what extent their PDE4 inhibition contributes to their anti-inflammatory effects or indeed to their side effect profile. Though 3c did not have these selectivity issues greater potency against PDE4 ($IC_{50} = 4.2\mu M$) would have been preferable. The SAR complications brought about by the potential overlapping pharmacologies meant that other chemical series were felt to be more attractive.

A similar SAR campaign to that carried out in the xanthine series was also performed for the aryl sulphonamides (publication 4). The template structure for these molecules was rolipram the archetypal PDE4 inhibitor. Clear improvements for *in vitro* selectivity of PDE4 inhibition over HARBS activity was achieved for the aryl sulphonamides with the lead molecule (compound 20) having a PDE4:RBA ratio of <0.6 compared to that of rolipram which was 175. This selectivity again translated into an *in vivo* therapeutic index. Compound 20 was efficacious in the guinea pig skin eosinophilia model at 5mg/kg, i.p. whilst not eliciting emesis in the ferret at 10 mg/kg, i.p. *In vivo* experimental work for these compounds was only carried out via the i.p. route due to the lack of potency against PDE4 (Compound 20, PDE4, $IC_{50} = 6\mu M$). Work on the aryl sulphonamide series was discontinued again due to lack of potency in favour of other chemical series.

In an attempt to inject chemical diversity, the PDE4 enzyme assay was re-formatted to allow high throughput screening to be performed. Molecules from a diverse range of chemical classes were screened for PDE4 inhibitory activity. From this screening campaign the quinolone series was identified (publication 5). Though again not potent the lead molecule 7 g had an IC_{50} against PDE4 of only 7 μM , the quinolones had little activity in the RBA and a therapeutic window of greater than 2 for efficacy in

the skin eosinophilia model over emesis in the ferret. The compounds from the quinolone series were however also found to be PDE3 inhibitors and though this may confer beneficial bronchodilator activity the accompanying cardiovascular liability was considered too great and when a strategy could not be found to eliminate this activity the series was abandoned.

From publication 2 it was evident that the most potent *in vitro* PDE4 inhibitor in development at the time was RP 73401. In the same publication it was also reported to be the most potent anti-inflammatory agent when dosed orally in the guinea pig skin eosinophilia model. This potency made RP 73401 the ideal candidate as the base molecule for the compounds tested in publication 6. The RP 73401 structure was modified to replace the 3, 4-dialkoxyphenyl group (also common to rolipram) with a benzofuran group, this modification had also been performed previously by Rhone-Poulenc Rorer¹. The resulting 7-methoxybenzofuran-4-carboxamide series were very potent compounds the lead molecule having an IC₅₀ against PDE4 of 0.0016 μM. Though the PDE4:RBA ratio was favourable for RP73401 SAR performed in the series managed to improve the ratio even further. The lead compound 3c had a ratio of 0.037 compared to rolipram, which was as previously stated 175 and RP 73401, 1.57. This improved ratio for 3c translated into an *in vivo* therapeutic window of >20 for oral efficacy in the skin eosinophilia model (0.5 mg/kg, po) over induction of emesis via oral dosing in the ferret (no activity at 10 mg/kg, po).

RP 73401 is known from the literature⁷² to have a poor pharmacokinetic profile due to metabolism by CYP2B6. The lead candidate from publication 6 (3c) was modified by replacement of the 7-methoxybenzofuran with 7-methoxyfuro[2,3-*c*]pyridine to try and improve the pharmacokinetics of the molecule. The improvement in pharmacokinetics for this modification is shown in publication 7 where oral administration of compound 8a is compared in the guinea pig with its 2-ethyl benzofuran equivalent and a 4.5 fold improvement in C_{max} is observed and a 3.5 fold improvement in AUC whilst retaining *in vitro* potency against PDE4 enzyme of 0.0014 μM. Efficacy for compound 8a via the oral route was demonstrated in the guinea lung eosinophilia model at 10 mg/kg. Unfortunately the compound was emetic at the same dose and route of administration in the ferret. The emetic nature of the compound was surprising given its PDE4:RBA ratio. No further work was carried out on the compound however so the reason for its unexpected emetic potency was not determined. It is possible that the change in pharmacokinetic properties may also have resulted in bio-distribution changes allowing 8a to more readily access the emetic centre of the brain and therefore able to more readily elicit emesis. In a publication by Aoki et al⁷⁴ the low emetogenicity of YM976 in the ferret when compared to rolipram, was thought to be due to the finding that it was less able to penetrate the brain than rolipram.

In publication 8 the chemistry moved away from the furan group replacing it with a quinoline. The nitrogen group was maintained however due to the pharmacokinetic advantages seen in publication 7. The initial introduction of the quinoline group led to a loss of potency, which was then restored on synthesis of the compound referred to as 3c in publication 8, which had an IC₅₀ against PDE4 of 0.17 μM. Though not as potent as the furans in publications 6 and 7 compound 3c successfully met all of the criteria outlined in Chapter 2 and was thus nominated into clinical development

proving to be a potent and selective agent both *in vitro* and *in vivo*. On nomination the molecule was re-named as D4418.

D4418 was tested in non-clinical toxicology and safety studies and found to have a good enough safety profile to enter clinical trials (Poster). It was progressed into a Phase I clinical trial in healthy volunteers where no signs of vomiting were observed; only mild side effects of headache, dizziness and nausea. Although efficacy was not measured in the trial the plasma levels obtained would have been sufficient to inhibit PDE4 enzyme activity based on the drug's IC_{50} in the PDE4 assay. In addition in a small number of patients effects were seen on whole blood measurements of TNF α and cAMP (data not submitted) though these were not significant. Overall the results were encouraging. To further improve on the potency of D4418 a collaboration was formed with the respiratory group at Schering Plough in the USA.

In publications 9, 10 and 11 the strategy outlined in Chapter 2 was maintained but more models were available for late stage testing of the compounds due to the collaboration with Schering Plough. The campaign to improve the potency of D4418 in this case did not involve a change of chemical class but remained inside the quinoline series. The development candidate nominated from this campaign was SCH 351591 which was approximately 3 times more potent than D4418 against PDE4 with efficacy in monkey and guinea pig respiratory models at doses as low as 0.3 mg/kg, p.o. whilst not eliciting emesis in the ferret at 5 mg/kg, po at plasma exposures (AUC $\mu\text{g}\cdot\text{h}/\text{mL}$) of 1.7 and 26.7. Based on the AUC values for D4418 in plasma, for the guinea pig efficacy and ferret emesis models SCH 351591 had a therapeutic window of 16. The data outlined in publication 11 allowed SCH 351591 to be nominated as the second development candidate.

5.2 Literature Citations

The two lead molecules which entered clinical development, D4418 and SCH351591 have been cited in various peer reviewed publications. In a book written by Beavo, Francis and Houslay¹ in 2007 publications 8, 9 and 11 are cited. The contribution made to PDE4 SAR by the work conducted on D 4418 and SCH 351591 is also discussed, as are the efficacy advances made in the benzofuran series outlined in publication 6.

In a PDE4 review in 2008 in the Journal of Medicinal Chemistry⁴² publications, 3, 4, 6, 7, 8, 9, 10 and 13 are all cited. Dialogue on the xanthine paper (publication 3) commented on the improvements of the molecules cited over theophylline and expounded on the clinical success of other structurally related xanthines namely doxofylline and cipamfylline. In relation to publication 4, the novelty of the sulphonamide series was commented upon, the authors discussed how the compounds maintained potency and selectivity both *in vitro* and *in vivo* showing the success of the early *in vitro* part of the screening cascade for predicting *in vivo* activity. The comments on publications 6 and 7 referred to the improvements in pharmacokinetics made for the benzofurans comparing it to the same publication from Rhone Poulenc Rorer, as cited in this thesis.⁵⁴ In the citing of publications 8, 9 and 10 Kodimuthali tells the story of the discovery of D 4418 and subsequently SCH 351591 and its metabolite showing the improvements in bioavailability from 62% in the guinea pig for D 4418 to 78% for SCH 365351 with the subsequent discovery of the toxicology

of SCH 351591 in monkeys and the varied conversion to SCH 365351 in different species.

5.3 Contribution to Subsequent PDE4 Inhibitor Research

The discovery of the potent, selective PDE4 inhibitor SCH 351591 with an improved therapeutic window of efficacy over emesis and the publication of its profile (publications 10 and 11) has led to a better understanding of molecules with similar profiles such as cilomilast (SB 207499).⁶⁰ The subsequent publication of the toxicology of SCH 351591 in monkeys⁵⁷ has indeed changed previously held theories that pathologies such as arteritis observed in rats^{58,60} and dogs for compounds such as rolipram⁵⁸ and cilomilast⁶⁰ were in fact due to the common occurrence of arteriopathies in these species. Studies of cilomilast in primates did not show these effects. Giembycz in 2005⁶² on reviewing the SCH 351591 toxicology study in cynomologous monkeys stated that ‘such discoveries of arteriopathy in primates, which were previously thought to be resistant to toxicity, have serious implications for human risk’. It may be that with previous molecules the dose limiting nausea and emesis have prevented the dosing of the PDE4 inhibitors to levels which cause these toxicities. Giembycz also cites in a later paper (2006)⁶⁰ how Merck abandoned their PDE4 inhibitor (licensed from Celltech-out of the CDP 840 stable) due to the incidence of colitis which they felt may be secondary to arteritis.

5.4 Conclusions

In the area of PDE4 inhibitor research a number of drugs have reached Phase III clinical trials for COPD (See Appendix 1) and demonstrated varying degrees of efficacy, (cilomilast, and arofylline). Others have shown promising animal data including D 4418 and SCH 351591 but until recently an inhibitor with a wide enough therapeutic index in man to push the dose sufficiently to allow increased efficacy to be obtained had not been found. Indeed drugs such as arofylline (LAS 31025) have failed to overcome the nausea and emesis associated with the first generation PDE4 inhibitors, whereas cilomilast and SCH 351591 using the HARBS/LARBS differentiating affinities, screening strategy have achieved this leading to higher doses being utilised in toxicology studies with the subsequent observation of arteritis. As the arteritis appeared to be a direct result of gastro-intestinal inflammation this observation in toxicology studies led the FDA to recommend the daily monitoring of all gastro-intestinal adverse events including colonoscopies in those subjects who reported one or more GI events of concern in the cilomilast trials.

The selection of compounds with higher affinity for the LARBS site over the HARBS site therefore appeared to be a good approach for the selection of compounds with a wider therapeutic index of anti-inflammatory efficacy over emesis. However on reducing emetic side effects and allowing higher drug exposures to be achieved the more severe findings of arteritis was observed which is difficult to monitor directly in clinical studies.

The work with direct delivery of compounds to the lung e.g. tofimilast^{63,64} has also had limited success with systemic exposure of drug still being achieved, resulting in nausea and emesis being observed in clinical studies.

The strategy of PDE4 subtype selectivity still remains to be fully exploited. The discovery of the association of the emetic side effects with PDE4D³⁰ isoenzyme and the dominance of PDE4B expression and functionality in neutrophils and monocytes (key inflammatory cells in COPD) presents PDE4B²⁸ selective inhibitors as a potentially useful target for the selection of anti-inflammatory molecules with reduced emetic side effects. A recent publication by Wang⁶⁹ et al shows the catalytic domain crystal structures of PDE4A, PDE4B, PDE4C and PDE4D with detailed structural comparisons revealing significant conformational differences. This could be useful in the design of selective inhibitors. Whether or not selective inhibitors of this nature will also cause arteritis or reveal other 'hidden' side effects and whether they will be capable of achieving adequate efficacy remains to be seen.

The recent approval in Europe of Daxas (Roflumilast) and the review of the drug's approval for use in the USA will no doubt more clearly define the role of PDE4 inhibitors in respiratory, and potentially other, forms of inflammation.

Chapter 6

6. Evolution of Cited Clinical Development Candidates

6.1 Piclamilast (RP 73401)

RP 73401 is a very potent and selective PDE4 inhibitor which reached Phase II clinical trials for asthma via the inhaled route and rheumatoid arthritis at low doses orally t.i.d. The dosing regimen used reflects the issues the compound has with nausea and vomiting but also its low oral bioavailability due to first pass metabolism. It is possible to avoid this metabolism by dosing via inhalation. The drug was under clinical development via the inhaled route but was discontinued as it was found to cause tumours of the nasal olfactory regions in a two year rat inhalation carcinogenicity study.

6.2 CDP840

CDP 840 completed a Phase IIa clinical trial for asthma via the oral route where it did show statistically significant inhibition when compared to placebo of an allergic response in asthma patients without significant nausea and emesis side effects. This was a breakthrough in the area of PDE4 research. However, no further clinical development was carried out with the molecule.

6.3 Arofylline (LAS31025)

Arofylline was designed to be a more potent xanthine than the first generation drugs from this class (such as theophylline). It is more potent against PDE4 than theophylline but like theophylline still has adenosine binding activity which makes it a PDE4 'plus' inhibitor. It reached Phase III trials for COPD and asthma via the oral route and showed improvements in forced expiratory volumes in 1 second (FEV₁), a clinical measure of improved airway function, in these studies. Efficacy was seen against exacerbations frequency in COPD and in a phase I study a 20 mg dose raised FEV₁ significantly 1hr after administration with a duration of action of approximately 8 hrs. An inhaled formulation was reported to have entered Phase I clinical trials⁶⁶ presumably to avoid side effects due to systemic exposure with the oral formulation.

Up to date information is not available as the originating company at the time was a privately owned Catalan (the company has subsequently been floated on the Spanish stock market), pharmaceutical company known as Almirall Prodesfarma. It is thought however that development of this product has ceased.

6.4 Cilomilast (SB207499)

Cilomilast or SB207499 is a GlaxoSmithKline compound (originally a SmithKline Beecham compound) designed to be selective for the LARBS (low affinity rolipram binding site) over the HARBS (high affinity rolipram binding site). The results in publication 4 submitted as part of this thesis show SB207499 to have an IC₅₀ against PDE4 (LARBS) of 0.23 μ M and rolipram binding (HARBS) of 0.07 μ M showing a marked improvement for selectivity for LARBS over HARBS when compared to

rolipram, which has IC_{50} s of 2.42 μ M and 0.05 μ M for PDE4 and rolipram binding, respectively.

Cilomilast was targeted initially at the treatment of asthma then later for the treatment of COPD. The drug has been successful in completing Phase I and II clinical trials showing safety, tolerability and a significant improvement in lung function and quality of life in COPD patients. A Phase II study⁶⁷ concluded that 15 mg cilomilast twice daily might be effective maintenance therapy for COPD. This success has led to a comprehensive Phase III programme to further investigate efficacy, safety and mechanism of action. In the Phase III trials 4 pivotal, multicentre, double-blind placebo controlled parallel group studies were set up⁶⁰, 2 in Europe and 2 in the USA to evaluate the effects of 15 mg cilomilast bid for 24 weeks in COPD. The results of these trials however were disappointing. The design of the initial 3 trials was to demonstrate a difference in FEV_1 between cilomilast and placebo treated groups of 120 mL based on results seen in Phase II studies of ~130 mL⁶⁷. However the results obtained were not clinically relevant and far less than effects normally seen with salbutamol (short-acting beta agonist) or theophylline. There were however improvements in quality of life scores throughout the studies some of which were significant. It may be possible to explain these disappointing results due to the dose used not being sufficiently high enough being only a 'borderline' efficacy dose. The dose used was selected from Phase I studies where doses of 15mg and above gave rise to dose limiting nausea and emesis. It may be possible to overcome these effects and reach higher doses via dose-escalation at 3-day intervals in fed patients, as tolerance to emesis has been shown to occur.⁶⁸

A possible explanation for the emesis occurring at the efficacious doses, which would not have been predicted from the HARBS:LARBS ratio is the fact that cilomilast is ~7-fold selective for PDE4D⁶⁹ over the other isozymes. It has been previously stated in the PDE4 subtype section of this thesis that PDE4D appears to be the isozyme responsible for the emesis and nausea related side effects.

An additional issue with cilomilast is the arteritis⁶⁹ which has been observed in rat toxicology studies at exposure levels five times lower than those achieved for the proposed clinical dose. This effect shows a very steep dose response relationship with no lesions at 20 mg/kg and clear lesioning at 30 mg/kg. These findings led the FDA (Food and Drug Administration) to request that GlaxoSmithKline included daily monitoring in clinical studies of all gastrointestinal adverse events of concern, and vital signs in supine sitting and standing positions to alert physicians of any signs of bowel infarction. Galxo SmithKline made the decision to halt the development of SB207499 in January 2008 for COPD. The development for this compound in asthma had been discontinued in 2001 (Investigational Drugs Database 3).

6.5 CP-671305

CP-671305 was under development by Pfizer as a PDE4D selective PDE4 inhibitor⁷¹. At the time PDE4D was thought to be the subtype of interest in inflammatory cells. It has an IC_{50} of 3 nM against PDE4D and is 96-fold selective against other PDE subtypes and extremely selective for other PDE families. Its *in vitro* profile in human whole blood assays shows it to inhibit leukotriene B4 production from neutrophils and eosinophils with IC_{50} 's of 52 nM and 106 mM, respectively. Its pharmacokinetic

profile in rats gave a half life of >5 hours and an oral availability of 43-80% and its half-life in dogs was similar with oral availability of 45% and in monkeys again a similar half-life was obtained with oral availability of 26%. It was active *in vivo* in the cynomolgous monkey eosinophilia model when dosed subcutaneously.

The evidence of an association of PDE4D with emesis³⁰ however had a very negative effect on this programme.

6.6 Tofimilast

Tofimilast is a selective PDE4 inhibitor developed by Pfizer as an inhaled product for the treatment of COPD in an attempt to avoid systemic side effects and improve delivery to the site of inflammation, namely the lungs. It is a purine⁴² based inhibitor structurally unrelated to rolipram. It was designed not to be PDE4 subtype selective but to have low oral bioavailability (not required as inhaled delivery), low emetic liability (no emesis was observed in ferrets at plasma concentrations of up to 152 ng/mL), and physical properties suitable for inhaled formulation. The low exposures were thought would limit its emetic liability.

In a study in mild asthmatics⁴³ presented at the ATS in 2007 in which 12 patients received inhaled tofimilast, 2 mg bid and matching placebo for 7.5 days in a randomised, double blind, two way cross-over design, tofimilast failed to significantly attenuate airway responses to either histamine or allergen challenge. In a larger study⁶³ in 87 asthma patients in which tofimilast was dosed at 0.55, 2, 4 or 6 mg bid with matching placebo all doses were safe and well tolerated but again the drug failed to demonstrate efficacy.

Tofimilast was also tested in an inhaled LPS study⁶⁴ in 20 healthy subjects in an attempt to model the inflammation observed in COPD. Subjects received 4 mg tofimilast bid or matching placebo for 7.5 days. LPS challenge was performed 30 mins post dose on day 8. Blood samples and sputum samples were analysed for neutrophil counts and cytokines levels. No significant difference was found between treatment groups.

6.7 Roflumilast (Daxas)

Roflumilast is a close analogue of RP73401 (piclamilast) and rolipram. The pyrrolidinone ring of rolipram is replaced in both molecules. When compared to piclamilast, which contains the rolipram 3-pentoxy-4-methoxyphenyl group, roflumilast has the 3-cyclopentoxy group replaced by a 3-cyclopropylmethoxy group and the 4-methoxy group replaced by a 4-difluoromethoxy group. When compared pharmacokinetically to piclamilast, roflumilast is less plasma protein bound and has a much improved bioavailability.¹

Roflumilast has a very complicated commercial history due to company mergers and acquisitions. Roflumilast originated in Byk Gulden, which then became Altana. Altana was subsequently, acquired by Nycomed. Altana had a licensing agreement with Pfizer (formerly Pharmacia) for joint marketing of roflumilast in Europe, USA and other markets. Pfizer terminated this agreement in 2005 and returned all rights to

Altana. In November 2002 Altana had an agreement with Tanabe Seiyaku to co-develop, promote and commercialise roflumilast in Japan, this arrangement was not affected by the termination of the Pfizer deal.

Roflumilast is a potent PDE4 inhibitor with an IC_{50} against human neutrophil PDE4 of around 0.8 nM.¹⁸ When dosed *in vivo* to various species including humans, roflumilast is metabolised to the pyridyl *N*-oxide which has a potency of 2 nM against human neutrophil PDE4¹⁸ and therefore potentially contributes to the pharmacological effects of roflumilast.

Roflumilast shows no selectivity for the PDE4 subtypes A, B and D and only 10-fold less potency against PDE4C¹⁸. It is however selective against the PDE isozymes 1, 2, 3 and 5 and shows inhibition *in vitro* of; LPS induced TNF α release in human monocytes, macrophages, dendritic cells and whole blood, and human T cell proliferation, and antibody induced, IL-2, IL-4, IL-5 and IFN γ release in T cells.¹⁸

In *in vivo* efficacy models¹⁸ roflumilast attenuated allergen induced bronchoconstriction when dosed orally with an ED_{50} of 1.5 μ mol/kg, its *N*-oxide showed equal potency with an ED_{50} of 1.0 μ mol/kg whereas reference inhibitors piclamilast, rolipram and cilomilast showed inferior potencies with ED_{50} 's of 8.0 μ mol/kg, 32.5 μ mol/kg and 2.2 μ mol/kg respectively. In an inflammatory model of antigen induced cell infiltration roflumilast and its *N*-oxide when administered via the oral route inhibited eosinophilia with ED_{50} 's of 2.7 and 2.5 μ mol/kg, respectively.

It is difficult to find literature data for the side effects induced by roflumilast except in clinical studies. In a publication by Kuss et al⁷⁰ however when dosed in pigs via the i.v. route the first emetic dose for roflumilast was 0.3 mg/kg, in the same study via the same dose route rolipram elicited emesis at the same dose. This group also looked at efficacy in an LPS induced lung neutrophilia model in Lewis rats where roflumilast failed to attenuate neutrophil infiltration at 0.1-1 mg/kg giving it a therapeutic index of <3.

Roflumilast has successfully completed a number of clinical studies. In a Phase I/II placebo-controlled, double-blind, 28 day, crossover study (500 μ g/day) the mean percentage FEV₁ was reduced by 40% when compared to placebo. In the same study *ex-vivo* LPS whole blood stimulation and measurement of TNF α was used a surrogate marker and a 21% decrease was observed in the treatment group.

Based on the results of Phase II trials in COPD roflumilast or Daxas has now been approved in the EU as a once a day medication for severe COPD. The FDA has asked Forest and Nycomed to submit additional information and analyses having previously voted against approval. The companies have not been asked to conduct additional studies.

References

1. Cyclic nucleotide phosphodiesterases in health and disease, edited by Beavo JA, Francis SH and Houslay M, *CRC Press* (2007).
2. Cyclic nucleotide phosphodiesterases and their role in immunomodulatory responses: advances in the development of specific phosphodiesterase inhibitors, Castro A, Jerez MJ, Gil C and Martinez A, *Med. Res. Rev.*, **25**(2): 229-244 (2005).
3. Phosphodiesterase 4 inhibitors for the treatment of asthma and COPD, Huang Z. and Mancini J.A., *Curr. Med Chem.*, **13**(27): 3253-3262 (2006).
4. The identification of a new cyclic nucleotide phosphodiesterase in human and guinea pig cardiac ventricle, implications for the mechanism of action of selective phosphodiesterase inhibitors, Reeves ML, Leigh BK, and England PJ, *Biochem. J.* **241**: 535-541 (1987).
5. Multiple isoenzymes of cyclic nucleotide phosphodiesterase, Beavo JA, *Adv. In Second Messenger and Phosphoprotein Research*, **22**: 1-38 (1988).
6. Overview of PDEs and their regulation, Omori K, and Kotera J, *Circ. Res.*, **16**: 100(3): 309-27 (2007).
7. Phosphodiesterase inhibitors, Cooper N, Gristwood RW, Krishna T, and Holgate S, *Therapeutic Immunology*, Blackwell Publishing, **10**: (2001).
8. Isolation and characterisation of a dual-substrate phosphodiesterase gene family: PDE10A, Soderling SH, Bayuga SJ, and Beavo JA, *Proc. Natl. Acad. Sci.*, **96**:7071.
9. Cloning and characterisation of PDE10A, a novel human 3'5',-cyclic nucleotide phosphodiesterase, Loughney K Snyder PB, Uher L, Rosman GJ, Ferguson K, and Florio VA, *Gene* **234**:109 (1999)
10. Cloning and characterisation of a novel human phosphodiesterase that hydrolyses both cAMP and cGMP (PDE10A), Fujishige, K, Kotera J, Michibata H, Yuasa K, Takebayashi S, Okumura K, and Omori K, *J. Biol. Chem.* **274**: 18438 (1999).
11. Molecular cloning and characterisation of a distinct human phosphodiesterase family: PDE11A, Fawcett, L, Baxendale R, Stacey P, McGrouther C, Harrow I, Soderling S, Hetman J, Beavo J A, and Phillips S C, *Proc. Natl. Acad. Sci.* **97**: 3702 (2000).
12. Phosphodiesterase inhibitors, Schudt C, Dent G and Rabe KF, *The Handbook of Immunopharmacology* (1996).
13. Phosphodiesterase-4 as a therapeutic target, Houslay MD, Schafer P and Zhang KYJ, *DDT*, **10**(22): 1503-1519 (2005).
14. Excitation of area postrema neurons by transmitters, peptides, and cyclic nucleotides, Carpenter DO, Briggs DB and Knox AP, *J. Neurophysiol.* **59**:358-36(1988).
15. Inhibitors of phosphodiesterase IV increase acid secretion in rabbit isolated gastric glands: correlation between function and interaction with a high-affinity rolipram binding site, Barnette MS, Grous M, Cielinski LB, Burman M, Christensen SB, and Torphy TJ, *J. Pharmacol. & Exp. Ther.*, **273**: 1396-1402 (1995).

16. Phosphodiesterase 4 inhibitors as a novel approach for the treatment of respiratory disease: cilomilast, Kroegel C, and Foerster M, *Exp. Opin. Investig. Drugs*, **16**(1): 109-124 (2007).
17. Phosphodiesterase isoenzymes, Torphy T, *Am. J. Respir. Crit. Care Med.*, **157**(2): 351-370 (1998).
18. Anti-inflammatory and immunomodulatory potential of the novel PDE4 inhibitor roflumilast *in vitro*, Hatzelmann A, and Schudt C, *J. Pharmacol. & Exp. Ther.*, **297**: 267-279 (2000).
19. New drugs for asthma, Barnes PJ, *Nature Reviews Drug Discovery*, **3**: 831-844, (2004).
20. Immunology of asthma and COPD Barnes PJ, *Nature Reviews Immunology*, **8**: 183-192 (2008).
21. Cytokines in asthma, Chung KF and Barnes PJ, *Thorax*, **54**: 825-857 (1999).
22. Immunologic and inflammatory mechanisms that drive asthma progression to remodelling, Broide DH, *J. Allergy Clin Immunol.*, **121**(3): 560-74, (2008).
23. Phosphodiesterase inhibitors, Boswell-Smith V, Spina D, and Page CP, *Br. J. Pharmacol.*, **147**: S252-S257 (2006).
24. Global initiative for the treatment of chronic lung disease, global strategy for the diagnosis management and prevention of COPD (updated 2007)
25. British Guideline on the Management of Asthma, Quick Reference Guide, Scottish Intercollegiate Guidelines Network, The British Thoracic Society, January 2003.
26. At least two genes reside within a large intron of the dunce gene of *Drosophila*, Chen CN, Malone T, Beckendorf SK, and Davis RL, *Nature*, **329**(6141):721-4 (1987).
27. Correlation between emetic effect of phosphodiesterase 4 inhibitors and their occupation of the high-affinity rolipram binding site in *Suncus murinus* brain, Hirose R, Manabe H, Nonaka H, Yanagawa K, Akuta K, Sato S, Ohshima E, and Ichimura M, *Eur. J. Of Pharmacol.*, **573**: 93-99 (2007).
28. Suppression of human inflammatory cell function by subtype-selective PDE4 inhibitors correlates with inhibition of PDE4A and PDE4B, Manning CD, Burman M, Christensen SB, Cielinski LB, Essayan DM, Grous M, Torphy T, and Barnette MS, *Br. J. Pharmacol.*, **128**: 1393-1398 (1999).
29. Phosphodiesterase 4B2 is the predominant phosphodiesterase species and undergoes differential regulation of gene expression in human monocytes and neutrophils, Wang P, Wu P, Ohleth KM, Egan RW, and Billah MM, *Mol. Pharmacol.*, **56**(1): 170-174 (1999).
30. Deletion of phosphodiesterase 4D in mice shortens α -adrenoreceptor mediated anesthesia a behavioural correlate of emesis, Robichaud A, Stamatiou PB, Jin SLC, Lachance N, MacDonald D, Laliberte F, Liu S, Huang Z, Conti M, and Chan CC, *J. Clin. Invest.* **110**(7): 1045-1052 (2002).
31. Isolation of similar rolipram-inhibitible cyclic-AMP-specific phosphodiesterases from rat brain and heart, Nemoz G, Moueqqit M, Prigent AF, and Pacheco H, *Eur. J. Biochem.*, **184**(3): 511-520. (1989).

32. Stereospecific binding of the anti-depressant rolipam to brain protein structures, Schneider HH, Schmiechen R, Brezinski M, and Seidler J, *Eur. J. Pharmacol.*, **127**: 105-115(1986).
33. Coexpression of human cAMP-specific phosphodiesterase activity and high affinity rolipram binding in yeast, Torphy T, Stadel JM, Burman N, Cielinski LB, McLaughlin MM, White JR, and Livi GP, *J. Biol. Chem.* **267**(3): 1798-1804 (1992).
34. Proposal for pharmacologically distinct conformers of PDE4 cyclic AMP phosphodiesterases, Souness JE, and Rao S, *Cell. Signal.* **9**(3/4): 227-236 (1997).
35. Conformational difference between PDE4 apoenzyme and holoenzyme, Laliberte F, Han Y, Govindarajan A, Giroux A, Liu S, Bobechko B, Lario P, Bartlett A, Gorseth E, Gresser M, and Huang Z, *Biochem.*, **39**: 6449-6458 (2000).
36. Dissecting the cofactor-dependant and independent bindings of PDE4 inhibitors, Liu S, Laliberte F, Bobechko B, Bartlett A, Lario P, Gorseth E, Van Hamme J, Gresser MJ, and Huang Z, *Biochem.*, **40**(34): 10179-10186 (2001).
37. The oligomerization state determines regulatory properties and inhibitor sensitivity of type 4 cAMP specific phosphodiesterases, Richter W, and Conti M, *J. Biol. Chem.*, **279**(29): 30338-30348 (2004).
38. The ability of phosphodiesterase IV to suppress superoxide production in guinea pig eosinophils is correlated with phosphodiesterase IV catalytic activity, Barnette MS, Manning CD, Cielinski LB, Burman M, Christensen SB, and Torphy TJ, *J. Pharmacol. & Exp. Ther.*, **273**: 674-679 (1995).
39. Association of the anti-inflammatory activity of phosphodiesterase 4 inhibitors with either inhibition of phosphodiesterase 4 catalytic activity or competition for [³H]Rolipram binding, Barnette MS, O'Leary Bartus J, Burman M, Christensen SB, Cielinski LB, Esser KM, Prabhakar US, Rush JA, and Torphy T, *Biochem. Pharmacol.*, **51**: 949-956 (1996).
40. Patent WO95/00139, (1995).
41. NVA237 and tiotropium bromide demonstrate similar efficacy in an anesthetized rabbit model of methacholine-induced bronchoconstriction. NVA237 demonstrates a reduced systemic pharmacological effect on cardiovascular parameters, Cooper N, Walker I and Knowles I, *ATS*, (2006).
42. Recent advances on phosphodiesterase 4 inhibitors for the treatment of asthma and COPD, Kodimuthali A, Lal Jabaris SS, and Pal M, *J. Med. Chem.*, **51**(18): 5471-89 (2008).
43. The inhaled PDE4 inhibitor tofemilast does not inhibit airway responses to allergen and histamine, Fregonese L, Grootendorst DC, Gauw SA, Wei CG, Bennetts M, Ward JK, Phillips PG, and Rabe KF, *ATS*, **A486**: #F50 (2007).
44. A comparison of the inhibitory activity of selective PDE4 inhibitors on eosinophil recruitment in guinea pig skin, Teixeira MM, Miotla JM, Cooper N, Gristwood RW, and Hellewell PG, *Mem. Inst. Oswaldo Cruz.* **92**(2): 193-6, (1998).
45. Anti-inflammatory and bronchodilator properties of RP 73401, a novel and selective phosphodiesterase type IV inhibitor, Raeburn D, Underwood SL, Lewis SA, Woodman VR, Battram CA, Tomkinson A, Sharma S, Jordan

- R, Souness JE, Webber SE, and Karlsson JA, *Br. J. Pharmacol.*, **113**: 1423-1431, (1994).
46. The inhibition of antigen-induced eosinophilia and bronchoconstriction by CDP 840, a novel stereo-selective inhibitor of phosphodiesterase type 4, Hughes B, Howat D, Lisle H, Holbrook M, James T, Gozzard N, Blease K, Hughes R, Kingaby R, Warrelow G, Alexander R, Head J, Boyd E, Eaton M, Perry M, Wales M, Smith B, Owens R, Catterall C, Lumb S, Russell A, Allen R, Merriman M, Bloxham D, and Higgs G, *Br. J. Pharmacol.* **118**: 1183-1191, (1996).
 47. Assay of cyclic nucleotide phosphodiesterases with radioactive substrates, Thompson WJ, Brooker G, and Appleman MM, *Methods Enzymol.*, **38**:205-12, (1974).
 48. Effects of phosphodiesterase isoenzyme inhibitors on cutaneous inflammation in the guinea pig, Teixeira MM, Rossi AG, Williams TJ, and Hellewell PG, *Br. J. Pharmacol.*, **112**: 332-340 (1994).
 49. LAS 31025 a new antiasthmatic compound combining airway antiallergic and bronchodilatory properties Bou J, Llupia J, Puig L, Salcedo C, Gras J, Beleta J, Fernandez AG, Llenas J, Berga P, Gristwood RW, and Palacios JM, IV Third international conference on cyclic nucleotide phosphodiesterase: - From genes to therapies; Glasgow (1996).
 50. SB 207499 (Ariflo), a potent and selective second-generation phosphodiesterase 4 inhibitor: *In Vitro* Anti-inflammatory Actions, Barnette MS, Christensen SB, Essayan DM, Grous M, Prabhakar U, Rush JA, Kagey-Sobotka A, and Torphy TJ, *JPET*, **284**: 420-426 (1998).
 51. Assay of cyclic nucleotide phosphodiesterase and resolution of multiple forms of the enzyme, Thompson WJ, Terasaki WL, Epstein PM, and Strada SJ, *Adv. Cyclic Nuc. Res.*, **10**: 69-92 (1979).
 52. Drugs for Asthma, Barnes PJ, *Br. J. Pharmacol.*, **147**: S297-S303, (2006).
 53. Cilostazol has beneficial effects in treatment of intermittent claudication: results from a multicenter, randomized, prospective, double-blind trial, Dawson DL, *Circulation*, **98**(7): 678-86 (1998).
 54. Benzofuran based PDE4 inhibitors, McGarry DG, Regan JR, Volz FA, Hulme C, Moriarty KJ, Djuric SW, Souness JE, Miller BE, Travis JJ, and Sweeney DM, *Bioorg. & Med. Chem.*, **7**(6): 1131-1139 (1999).
 55. Difficult Asthma, Dunitz, Holgate ST, Boushey HA, and Fabbri LM (1999).
 56. The safety and tolerability of Ariflo (SB 207499), a novel and selective phosphodiesterase 4 inhibitor, in healthy male volunteers, Murdoch RD, *Am. J. Resp. & Crit. Care Med.*, **157**(Suppl): A409. (1998).
 57. The toxicity of SCH 351591, a novel phosphodiesterase-4 inhibitor in cynomolgous monkey, Losco PE, Evans EW, Barat SA, Blackshear PE, Reyderman L, Fine JS, Bober LA, Anthes JC, Mirro EJ, and Cuss FM, *Tox. Path.*, **32**: 295-308 (2004).
 58. The toxicity of repeated exposures to rolipram, a type phosphodiesterase IV inhibitor, in rats, Larson JL, Pino MV, Geiger LE, and Simeone CR, *Pharmacol. Toxicol.*, **78**: 44-9 (1996).
 59. Differential type 4 cAMP-specific PDE4 expression functional sensitivity to PDE4 inhibitors among rats, monkeys and humans, Bian H, Zhang J, Wu P, Varty LA, Jia Y, Mayhood T, Hey JA, and Wang P, *Biochem. Pharmacol.* **1**; **68**(11): 229-36 (2004).

60. An update and appraisal of the cilomilast Phase III clinical development programme for COPD, Giembycz M, *Br. J. Clin. Pharmacol.* **62**(2): 138-152 (2006).
61. Discovery of a highly potent series of oxazole-based phosphodiesterase 4 inhibitors, Kuang R, Shue SJ, Blythin DJ, Shih NY, Gu D, Chen X, Schwerdt J, Lin L, Ting PC, Zhu X, Aslanian R, Piwinski JJ, Xiao L, Prelusky D, Wu P, Zhang J, Zhang X, Celly CS, Minnicozzi M, Billah M, and Wang P, *Bioorg. Med. Chem. Letts.*, **17**: 5150-5154 (2007).
62. Life after PDE4: overcoming adverse events with dual-specificity phosphodiesterase inhibitors, Giembycz MA, *Curr Opin Pharmacol.* **5**: 238-244 (2005).
63. A randomized, double-blind, placebo-controlled, parallel group, six-week study of the efficacy and safety of tofimilast dry powder for inhalation (DPI) in adults with persistent asthma, Danto S, Wei GC, and Gill J, *ATS*, **A485**: #F44 (2007).
64. A study to investigate the effect of the phosphodiesterase type 4 (PDE4) inhibitor, tofimilast on induced sputum and systemic inflammatory markers following inhaled lipopolysaccharide (LPS) challenge in healthy subjects, Tan EF, Ward JK, Bennets M, Wei GCG, Hidi R, Greenaway SD, Dearie PS, Ledbetter CL, and O'Connor BJ, *ATS*, **A132**: #A33 (2007).
65. Structures of the 4 subfamilies of PDE4 provide insight into the selectivity of their inhibitors, Wang H, *Biochem. J.*, **408**(2): 193-201 (2007).
66. A scintigraphic study to evaluate the deposition patterns of a novel anti-asthma drug inhaled from the cyclohaler dry powder inhaler, Newman SP, Rivero X, Luria X, Hooper G and Pitcairn GR, *Adv. Drug Deliv. Rev.* **26**(1), 59-67 (1997).
67. Cilomilast, a selective phosphodiesterase-4 inhibitor for treatment of patients with COPD: a randomised, dose ranging study, Compton CH, Gubb J, Nieman R, Edelson J, Amit O, Baskt A, Ayers JG, Creemers JPHM, Schultze-Werninghaus G, Brambilla C, and Barnes NC, *Lancet*, **358**: 265-70 (2001).
68. An overview of the pharmacokinetics of cilomilast (Ariflo), a new, orally active phosphodiesterase 4 inhibitor, in healthy young and elderly volunteers, Zussman BD, Benincosa LJ, Webber DM, Clark DJ, Cowley H, Kelly J, Murdoch RD, Upward J, Wyld P, Port A, and Fuder H, *J. Clin. Pharmacol.*; **41**(9): 950-8 (2001).
69. Phosphodiesterase-4 inhibitors as a novel approach for the treatment of respiratory disease:cilomilast, Kroegel C, and Foerster M, *Exp. Opin. Investig. Drugs*, **16**(1): 109-124 (2007).
70. In vivo efficacy in airway disease models of N-(3,5-dichloropyrid-4-yl)-[1-(4-fluorobenzyl)-5-hydroxy-indole-3-yl]-glyoxylic acid amide (AWD 12-281), a selective phosphodiesterase 4 inhibitor for inhaled administration, Kuss H, Hoefgen N, Johanssen S, Kronbach T, and Rundfelt C, *J. Pharmacol. & Exp. Ther.*, **307**(1): 373-85 (2003)
71. Inhibitors of PDE4: a review of recent patent literature, Odingo JO, *Exp. Opin. Ther. Patents*, **15**(7): 777-787 (2005).
72. Human liver CYP2B6- catalyzed hydroxylation of RP 73401, Stevens JC, White RB, Hsu SH, and Martinet M, *JPET*, **282**:1389-1395 (1997).

73. Cisplatin-induced emesis in the ferret: a new animal model, Florczyk AP, Schurig JE, and Bradner WT, *Cancer Treat. Rep.*, **66**(1):187-9 (1982).
74. Studies on mechanisms of low emetogenicity of YM976, a novel phosphodiesterase type 4 inhibitor, Aoki M, Fukunaga M, Sugimoto T, Hirano Y, Kobayashi M, Honda K, and Yamada T, *JPET*, **298** (3):1142-1149 (2001).
75. Selective phosphodiesterase inhibitors modulate the activity of alveolar macrophages from sensitized guinea-pigs, Germain N, Bertin B, Legendre A, Martin B, Lagente V, Payne A, Boichot E, *Eur Respir J*, **12**:1334–1339 (1998).
76. The cytokine network in asthma and chronic obstructive pulmonary disease, Barnes PJ, *J of Clin Invest*, **118**(11):3546-3556 (2008).
77. Cytokines as targets in chronic obstructive pulmonary disease, Chung KF, *Curr. Drug Targets*, **7**(6):675-81, (2006).
78. Effects of inhibitors of phosphodiesterase, on antigen induced bronchial hyperactivity in conscious sensitized guinea-pigs and airway leukocyte infiltration, Danahay H, Broadley KJ, *British Journal of Pharmacology*, **120**, 289-297, (1997).
79. New therapies for asthma: is there any progress? Barnes PJ, *TiPS*, 31, 335-343 (2010).

Appendix 1

Other Publications by the Author

Published Review Articles

1. Phosphodiesterase Inhibitors, *Therapeutic Immunology*, Chapter 10, Cooper N, Gristwood RW, Krishna T, Holgate S, Blackwell Publishing (2001).
2. Phosphodiesterase (PDE)4 inhibitors: anti-inflammatory drugs of the future? Teixeira MM, Gristwood RW, Cooper N, Hellewell PG, *Trends Pharmacol. Sci.* **18**: 164-71 (1997).

Posters

1. Modulation of peristalsis by PDE inhibitors. Tuladhar BR, Cooper N, and Naylor RJ, 1997, William Harvey Research Conference, Royal College of Physicians, London.
2. Inhibition of peristalsis with PDE4 but not PDE3 inhibitors in the guinea-pig isolated ileum. Tuladhar BR, Cooper N, and Naylor RJ, 1997, *BPS*, Harrogate, UK.
3. D 4418 - A New PDE4 Inhibitor for the Treatment of Asthma. Montana J, Cooper N, Hunt H, *ERS*, Madrid, Spain (1999)
4. Activity of D 4418 a novel phosphodiesterase 4 (PDE4) inhibitor, effects in cellular and animal models of asthma and early clinical studies, Montana J, Cooper N, Dyke H, Oxford J, Gristwood R, Lowe C, Kendall H, Buckley G, Maxey R, Warneck J, Gregory J, Gowers L, Galleway F, Wills R, Naylor R, Tuladhar B, Broadley K, Danahay H, *ATS*, San Diego, USA, (1999).
5. NVA237 Demonstrates a Reduced Systemic Pharmacological Effect on Cardiovascular Parameters, Cooper N, Knowles I, *ATS*, San Diego, USA (2006).
6. NVA237 and Tiotropium Bromide Demonstrate Similar Efficacy in an Anesthetized Rabbit Model of Methacholine-Induced Bronchoconstriction. Cooper N, Walker I, and Knowles I, *ERS*, Munich, Germany (2006).

Oral presentations

4th International World Congress on Inflammation, Paris, France, Cooper N, “Activity of D 4418, a Novel Phosphodiesterase 4 (PDE4) Inhibitor” (1999).

Appendix 2: Publications Submitted for this Thesis

Phosphodiesterase (PDE)4 inhibitors: anti-inflammatory drugs of the future?

Mauro M. Teixeira, Robert W. Gristwood, Nicola Cooper and Paul G. Hellewell

Phosphodiesterase type 4 (PDE4) plays a major role in modulating the activity of virtually all cells involved in the inflammatory process. Inhibitors of this enzyme family display impressive anti-inflammatory and disease-modifying effects in a variety of experimental models. In this review, **Mauro Teixeira, Robert Gristwood, Nicola Cooper and Paul Hellewell** examine the capacity of PDE4 inhibitors to exert anti-inflammatory actions *in vivo* and discuss the potential of this class of drugs to take their place as novel therapeutic agents for a variety of inflammatory diseases.

Recruitment of leukocytes from the blood compartment into tissues is essential for the host's response to infectious organisms such as bacteria and viruses. If the host's immune and inflammatory responses are properly controlled, the invading microorganism will be destroyed and recuperation of function is virtually complete. However, an initially protective immune response may lead to permanent damage if not controlled, if prolonged or if directed against self. Asthma, arthritis and multiple sclerosis are all examples of chronic immune deregulation accompanied by intense infiltration of tissues with inflammatory cells. In these conditions, chronic inflammation may lead to severe loss of function and to life-threatening situations. Similarly, acute deregulation of the immune system may occur in diseases such as the acute respiratory distress syndrome (ARDS), where an overwhelming and generalized inflammatory response leads to acute incapacitation and frequently to death. For some of these chronic inflammatory conditions (eg. asthma), steroids, sometimes at high doses, are the mainstay of therapy¹. However, these drugs can have many harmful side-effects when used chronically, including immunosuppression, metabolic disturbances and hypertension. For rheumatoid arthritis, nonsteroidal anti-inflammatory drugs (NSAIDs) offer palliative symptomatic treatment but their known side-effects are of great concern. For other conditions (eg. ARDS), no suitable therapeutic options exist and treatment is largely supportive. Thus, the development of drugs with an effective anti-inflammatory profile, but with fewer side-effects than steroids and the NSAIDs, would be

beneficial as there are few other therapeutic options in a number of diseases where an uncontrolled inflammatory response exists.

A strategy that has received much attention lately, especially within the context of asthma, relates to the level of cAMP in cells that participate in the inflammatory process. The elevation of intracellular cAMP has been associated with inhibition of the function of various types of cells including lymphocytes, monocytes, macrophages, neutrophils, eosinophils, mast cells, basophils, endothelial cells and lung epithelial cells^{2,3}. The mechanisms by which cAMP modulates cell function are not completely understood but appear to depend on the activation of protein kinase A and subsequent phosphorylation of hydroxy-amino acid residues or regulatory subunit-dependent transport of cAMP to the cytoplasm and nucleus⁴. The intracellular levels of cAMP are regulated by the rate of cAMP production by receptor-coupled adenylate cyclase and the rate of cAMP degradation by 3',5'-cyclic nucleotide phosphodiesterases (PDEs). Based on genetic, biochemical and pharmacological data, PDE isoenzymes have been classified into seven distinct families⁵. Of these, PDE3, PDE4 and PDE7 appear to be most important for the regulation of cAMP in different cell types. Interestingly, inhibitors of PDE4 have been shown to suppress, with a range of efficacies, the *in vitro* functional responses of most cells involved in the inflammatory process^{2,3} (Table 1). Whereas in neutrophils, eosinophils, mast cells and basophils PDE4 isoenzymes play a more dominant role, in monocytes/macrophages and lymphocytes PDE3 isoenzymes are also involved in the regulation of cAMP levels and PDE3 inhibitors appear to synergize with inhibitors of PDE4 (Table 1). The contribution of PDE7 awaits the availability of specific inhibitors of this isoform.

Effects of PDE4 inhibitors on models of inflammatory diseases *in vivo*

Table 2 describes the effects of PDE4 inhibitors in various 'models' of inflammatory diseases in animals. Despite the spectrum of tissues affected and cell types involved, a consistent finding was that PDE4 inhibitors effectively suppressed inflammation and disease activity. Most of the studies investigating the anti-inflammatory effects of PDE4 inhibitors *in vivo* have focused on allergic diseases, particularly in 'models' of asthma (Table 2). The great interest in allergic diseases is not surprising inasmuch as there is extensive evidence to suggest an involvement of eosinophils in these conditions and PDE4 inhibitors are effective inhibitors of eosinophil activation *in vitro*⁶. In addition, in the context of asthma, PDE4 inhibitors may provide the additional benefit of bronchodilatation and synergism with β_2 -adrenoceptor agonists^{3,7}. Thus, a number of structurally unrelated PDE4 inhibitors have been shown to suppress eosinophil recruitment induced by antigen challenge and a range of stimuli in the lungs, skin and eyes (Table 2). Furthermore,

M. M. Teixeira,

Post-doctoral
Research Fellow,
Applied
Pharmacology,
Imperial College of
Medicine, National
Heart and Lung
Institute, Dovehouse
Street, London, UK
SW3 6LY.

R. W. Gristwood,

Director,
Stevenage
Biosciences Ltd,
8, Nursery Close,
Stevenage,
UK SG2 8SD.

N. Cooper,

Group Leader in
Biochemistry,
Chiroscience Limited,
Cambridge Science
Park, Milton Road,
Cambridge,
UK CB4 4WE,
and

P. G. Hellewell,

Senior Lecturer,
Applied
Pharmacology,
Imperial College of
Medicine, National
Heart and Lung
Institute, Dovehouse
Street, London, UK
SW3 6LY.

these drugs can also reduce the increased levels of eosinophil-derived secretory products (e.g. eosinophil peroxidase) in the lung and the airway hyper-responsiveness observed after antigen challenge or after exposure to irritants, such as ozone. Interestingly, in some studies⁸⁻¹⁰ PDE4 inhibitors preferentially suppressed the recruitment of eosinophils, but not neutrophils, which suggests either a greater sensitivity of eosinophils to inhibition by these drugs or preferential inhibition of an eosinophil-specific recruitment pathway.

A number of investigations have evaluated the effects of various PDE4 inhibitors in animal models of septic shock, particularly in models that use systemic injection of high doses of lipopolysaccharide (LPS) (Table 2). The efficacy of PDE4 inhibitors in these models is very impressive and includes inhibition, very often complete, of LPS-induced increases in serum levels of tumour necrosis factor- α (TNF- α) in liver injury, bowel injury, lung injury, renal failure and mortality. In the context of acute lung injury, PDE4 inhibitors have been shown not only to inhibit the accumulation of neutrophils but also to reduce neutrophil-dependent oedema and the elevated level of neutrophil-derived elastase in lung tissue.

Three studies have evaluated the effects of the prototype PDE4 inhibitor rolipram on animal models of autoimmune encephalomyelitis (multiple sclerosis), a T-lymphocyte- and TNF- α -dependent demyelinating disease of the CNS (Table 2). Although rolipram had little effect on the induction phase of the disease, it markedly suppressed the pathological, clinical and radiological signs of encephalomyelitis when administered before these symptoms appeared¹¹⁻¹³. Furthermore, in one study, rolipram also significantly reduced the severity of the disease and inflammatory lesions in the brain when administered after the first clinical signs had appeared¹¹.

There is now substantial evidence to suggest that inflammation may play an important role in defining the extent of tissue injury following ischaemia and reperfusion¹⁴. In this context, rolipram inhibited ischaemia-reperfusion injury in the brain and lung, although it failed to modify injury to the heart (Table 2). The inability of rolipram to modulate myocardial reperfusion injury could relate to the observation of delayed protective effects of prostacyclin analogues in the heart. Following prolonged exposure to 7-oxo-prostacyclin, there is a cycloheximide-sensitive enhanced expression of PDE1 and PDE4 isoenzymes in ventricular muscles of the rat¹⁵. Thus, on the one hand, the enhanced expression of PDE isoforms leads to attenuation of adrenoceptor-mediated responses and to delayed cardiac protection¹⁶. On the other hand, inhibition of PDE4 by rolipram could enhance the adrenoceptor-mediated responses and counterbalance any protective anti-inflammatory effect of the drug following reperfusion in the heart.

Anti-inflammatory effects of PDE4 inhibitors have been demonstrated in a rodent model of rheumatoid

Table 1. Cells involved in the inflammatory process whose functions are known to be suppressed *in vitro* by phosphodiesterase (PDE)4 inhibitors

Cell type	Activity suppressed	Refs
Neutrophils	Respiratory burst, enzyme release, lipid mediator and cytokine production, phagocytosis, chemotaxis, elevation of free intracellular Ca ²⁺ , upregulation of CD11/CD18 expression on the cell surface	36, 63-65
Eosinophils	Respiratory burst, enzyme release, chemotaxis, lipid mediator production, homotypic aggregation, elevation of free intracellular Ca ²⁺	66-68
Mast cells	Mediator release	69
Basophils	Mediator release	70, 71
Lymphocytes ^a	Proliferation, cytokine production, cytotoxicity	11, 72, 73
Monocytes/macrophages	Respiratory burst, cytokine production, elevation of free intracellular Ca ²⁺	32, 74, 75
Mesangial cells ^a	Proliferation, respiratory burst	76, 77
Endothelial cells ^a	Permeability, expression of cell adhesion molecules, neutrophil adhesion	35, 78

^aInhibitory effects can be potentiated by concomitant PDE3 inhibition. For a more complete list of studies, see Refs 3, 63.

arthritis. Both rolipram and CP77059 significantly suppressed ankle swelling and radiological evidence of cartilage injury in a rat arthritis model¹⁷. In a rat model of glomerulonephritis with mesangial cell proliferation, treatment with rolipram and a PDE3 inhibitor suppressed proteinuria and proliferative changes¹⁸. In addition, the PDE4 inhibitor Ro20-1724 effectively suppressed the loss of dopaminergic neurones in a mouse model of Parkinson's disease¹⁹, indicating another disease condition in which PDE4 inhibitors, in theory, have potential utility.

Mechanisms of the anti-inflammatory action of PDE4 inhibitors *in vivo*

Inhibitors of PDE4 are effective suppressors of cytokine production by different cell types *in vitro*^{2,3} and reduce serum TNF- α levels in animal models of septic shock (e.g. Refs 17, 20, 21) (Box 1). More importantly, inhibition of TNF- α release appears to play an important role in the anti-inflammatory effects of PDE4 inhibitors^{22,23}. Suppression of the release of chemoattractants, including the α -chemokine interleukin-8 (IL-8)²⁴ and the lipid leukotriene (LT)B₄ (Ref. 25), may also be important for the inhibition of leukocyte recruitment by PDE4 inhibitors. Inhibition of chemokine production, particularly those that are leukocyte-specific chemoattractants, could comprise an important component of the anti-inflammatory action of PDE4 inhibitors *in vivo*.

Pettipher and colleagues recently showed that the inhibition by rolipram of TNF- α release in the peritoneal cavity of thioglycollate-treated mice was dependent on the release of corticosterone²⁰. Similarly, the PDE4 inhibitors rolipram, denbufylline and BRL61063 have all been shown to produce increases in adrenocorticotrophic

Table 2. The effects of phosphodiesterase (PDE)4 inhibitors in experimental models of inflammation *in vivo*

Condition modelled	Species	Parameters measured	PDE4 inhibitor used	Route of administration	Effects observed	Refs
Allergic diseases – asthma	Monkey	Antigen-induced BAL eosinophils, IL-1, IL-6, IL-8 and AHR	Rolipram	s.c.	Inhibition	24
	Monkey, guinea-pig	Antigen-induced EPO in lung, bronchoconstriction, BAL neutrophils and eosinophils	CP80633	p.o., s.c.	Inhibition	79
	Guinea-pig	PAF-induced airway oedema	Rolipram	Topical	Inhibition	80
	Guinea-pig	Airway oedema	Rolipram	i.v.	Inhibition	81
	Guinea-pig	Antigen-induced BAL eosinophils, oedema, and AHR	Rolipram	Inhaled/i.p.	Inhibition	26
	Guinea-pig	Antigen-induced BAL eosinophils and histology	Rolipram	p.o.	Inhibition	82
	Guinea-pig	Antigen-induced BAL eosinophils, neutrophils and AHR	Rolipram	i.p. (low doses)	Inhibition of neutrophils	83
	Guinea-pig	Ozone-induced AHR	Rolipram, CDP840, RP73401	p.o./i.p.	Inhibition of AHR CDP840>>rolipram>RP73401	84
	Guinea-pig	Antigen-induced lung eosinophilia and EPO	Rolipram, RP73401	i.p. (7 days)	Eosinophils inhibited only by RP73401	85
	Guinea-pig	Antigen-induced BAL eosinophils	Rolipram, zardaverine ^a	p.o.	Marginal inhibition	86
	Guinea-pig	IL-5- and IL-8-induced BAL eosinophils	Rolipram, Ro20-1724	p.o.	Inhibition	87
	Guinea-pig	Antigen-induced BAL eosinophils	Rolipram, zardaverine ^a	i.p.	Inhibition after chronic administration only	88
	Guinea-pig	Antigen-induced eosinophils and EPO in BAL	Rolipram, Ro20174	p.o.	Inhibition	89
	Guinea-pig, rat	Antigen-induced BAL eosinophils	Rolipram, RP73401	i.t.	Inhibition (higher doses in rat)	90
	Guinea-pig, rat	Antigen-induced lung eosinophilia and IL-5-induced pleural eosinophilia	Rolipram, CDP840, RP73401	p.o./i.p.	Inhibition CDP840>=RP73401>rolipram	29
Rat	Antigen-induced BAL neutrophils and eosinophils	Rolipram, ORG20241 ^a	p.o.	Inhibition	91	
Rabbit	Antigen-induced AHR and eosinophilia	CDP840	i.p.	Inhibition of both and of acute bronchospasm	9	
Rabbit	Antigen-induced AHR and eosinophilia	Rolipram	i.p.	Inhibition of both, no change neutrophils	92	
Allergic diseases – eye	Guinea-pig	Histamine- and leukotriene-induced eosinophilia	Rolipram, zardaverine ^a	p.o.	Inhibition	93
Allergic diseases – skin	Guinea-pig	Allergen- and mediator-induced eosinophilia	Rolipram	i.p.	Inhibition	8
Rheumatoid arthritis	Rat	Ankle swelling and radiological evidence	Rolipram, CP77059	p.o.	Inhibition (CP77059>rolipram)	17
Glomerulonephritis	Rat	Proteinuria, histology	Rolipram and PDE3 inhibitor	Minipump infusion	Inhibition of proteinuria, mesangial proliferation and monocyte infiltration	18

Table 2. The effects of phosphodiesterase (PDE)4 inhibitors in experimental models of inflammation *in vivo* (contd)

Condition modelled	Species	Parameters measured	PDE4 inhibitor used	Route of administration	Effects observed	Refs
Septic shock	Mouse	Serum TNF- α , lethality	Rolipram, BRL61063	p.o./i.p.	Inhibition	94
	Mouse	Serum TNF- α , liver injury	Rolipram, zardaverine ^a	p.o.	Inhibition	95
	Rat	Bowel haemorrhage	Rolipram, denbufylline	i.p.	Inhibition	96
	Dog	Mesenteric hypoperfusion	Denbufylline	i.v. infusion	Reversal	96
	Rat	Serum TNF- α	Rolipram	i.v.	Inhibition	21
	Mouse	Serum TNF- α , LPS-induced lethality	Rolipram, CP77059	p.o.	Inhibit TNF- α at lower doses	97
	Mouse	Local and systemic TNF- α , levels	Rolipram	p.o.	Inhibition (locally is dependent on adrenal hormones)	20
	Mouse	Serum TNF- α , lethality	Rolipram, CP77059	p.o.	Inhibition (CP77059> rolipram)	17
	Rat	Renal blood flow, vascular resistance, glomerular filtration rate	Ro20-1724	i.v. infusion	Reversal of LPS-induced effects	98
Acute respiratory distress syndrome	Rat	Serum TNF- α , lethality, pulmonary oedema, liver injury, lung neutrophils	Rolipram	p.o.	Inhibition of all except pulmonary oedema	22
	Rat	Lung neutrophils, elastase activity and AHR	Zardaverinea	i.p.	Inhibition	99
	Rat	IL-2-induced pulmonary oedema, lung neutrophils, lung TNF- α	Rolipram	i.v.	Inhibition	23
	Guinea-pig	Lung oedema and neutrophils after aerosolised LPS	Rolipram, denbufylline	p.o., i.p.	Inhibition of all but lung neutrophilia	10
Multiple sclerosis	Non-human primate	Clinical signs, MRI, histology	Rolipram	s.c.	Amelioration	12
	Rat	Functional impairment, histology	Rolipram	i.p.	Amelioration and delay in progression	11
	Rat	Functional impairment, histology	Rolipram	i.p.	Delay and slight amelioration when given as preventive treatment; no effect after disease onset	13
Ischaemia-reperfusion injury – brain	Gerbil	Histopathology, hyperthermia	Rolipram	i.p.	Diminished neuronal death	100
Ischaemia-reperfusion injury – heart	Dog	Infarct size and MPO levels	Rolipram	Infusion	No effect	64
Ischaemia-reperfusion injury – lung	Rat	Filtration coefficient, histology, oedema	Rolipram	<i>Ex vivo</i>	Inhibition	101
Parkinson's disease	Mouse	Neuronal loss	Ro20-1724, MNS949	s.c.	Inhibition	19

^aPDE3 and PDE4 inhibitor. BAL, bronchoalveolar lavage; AHR, airway hyperresponsiveness; EPO, eosinophil peroxidase; i.p., intraperitoneal; i.t., intratracheal; i.v., intravenous; LPS, lipopolysaccharide; MRI, magnetic resonance imaging; MPO, myeloperoxidase; PAF, platelet-activating factor; p.o., oral; s.c., subcutaneous; TNF- α , tumour necrosis factor- α . Table 2 contains all references in MEDLINE that report an effect of PDE4 inhibitors on a defined inflammatory condition.

Box 1. Possible mechanisms involved in the anti-inflammatory action of phosphodiesterase (PDE)4 inhibitors *in vivo*

- Inhibition of the release of inflammatory mediators/cytokines
- Inhibition of leukocyte activation (degranulation, respiratory burst)
- Inhibition of leukocyte migration
- Inhibition of the expression/upregulation of cell adhesion molecules
- Induction of cytokines with suppressive activity (e.g. interleukin-10)
- Induction of apoptosis
- Stimulation of endogenous steroids and catecholamine release

hormone (ACTH) and corticosterone secretion in the rat^{27,28}. Moreover, part of the inhibitory effects of rolipram on systemic TNF- α release after LPS treatment was dependent on the release of adrenaline²⁰ and β -adrenoceptor block reversed the inhibition by rolipram of arachidonic acid-induced oedema in mouse ear²⁵. It is clear that these actions should be considered when evaluating the anti-inflammatory actions of these and other PDE4 inhibitors in different animal models. More recently, however, it was reported that the effects of the PDE4 inhibitor CDP840 on IL-5-induced pleurisy in the rat were not modified by adrenalectomy or β -adrenoceptor block²⁹. Whether such effects of PDE4 inhibitors occur in humans is unknown.

There are protective effects of PDE4 inhibitors in experimental inflammation that are clearly independent of inhibition of the release and action of TNF- α and other mediators^{8,17,30}. For example, rolipram has been shown to inhibit TNF- α release at doses considerably lower than those necessary to prevent lethality following challenge with LPS (Ref. 17) and it also prevented the accumulation of eosinophils induced by intradermal injection of preformed, direct-acting mediators⁸. This latter observation is consistent with a direct effect of rolipram on the eosinophil³¹. It is also clear that cAMP-elevating agents such as PDE4 inhibitors induce the production of IL-10 by macrophages exposed to LPS *in vitro*³²; the released IL-10 contributes to the inhibitory effects of PDE4 inhibitors on TNF- α and IL-6 release³². Although there have been no studies evaluating the role of IL-10 in the anti-inflammatory effects of PDE4 inhibitors *in vivo*, enhanced production of IL-10 appears to play a role in the protective effects of methylxanthines in a murine model of septic shock³³.

In addition to preventing or inducing the release of cytokines, PDE4 inhibitors potently block the activation of leukocytes *in vitro* (Table 1). It is thus possible that inhibition of leukocyte activation may be important for some of the anti-inflammatory effects of PDE4 inhibitors *in vivo*. For example, in a mouse model of acute lung

injury induced by LPS followed by zymosan, rolipram effectively inhibited lung injury when given before or after the LPS (Ref. 30). This protective effect of rolipram was independent of the inhibition of TNF- α release and of neutrophil sequestration in the lung and also occurred when zymosan was injected alone; this suggests that inhibition of neutrophil activation was the likely mechanism of action. With respect to allergic inflammation, suppression of eosinophil activation in addition to inhibition of mast cell degranulation may play an important role in the protective effects of PDE4 inhibitors in animal models of asthma²⁹.

Another interesting and potentially important anti-inflammatory effect of PDE4 inhibitors relates to the ability of cAMP-elevating agents to modulate the expression of cell adhesion molecules *in vitro*. For example, combination treatment with the adenylate cyclase stimulator forskolin and the nonspecific PDE inhibitor isobutyl methylxanthine suppressed the induction by cytokines of endothelial E-selectin and vascular cell adhesion molecule-1 (VCAM-1)³⁴. Similarly, rolipram significantly suppressed the expression and release of E-selectin in TNF- α -stimulated human umbilical vein endothelial cells³⁵. In addition, cAMP-elevating agents also prevent mediator-induced upregulation of β_2 integrins on the surface of eosinophils and neutrophils^{36,37}. Whether inhibition of the expression and/or upregulation of cell adhesion molecules plays a role in the anti-inflammatory effects of PDE4 inhibitors *in vivo* is unclear, and deserves further investigation. Finally, the accumulation of leukocytes in different tissues is defined not only by their rate of recruitment into tissue but also by their rate of clearance via apoptotic mechanisms^{38,39}. Overall, cAMP-elevating agents tend to enhance apoptosis of various leukocytes *in vitro* (e.g. Refs 40–42). Whether PDE4 inhibitors exert similar effects to other cAMP-elevating agents and whether these will be relevant for their anti-inflammatory action *in vivo* is not known. It is interesting to note that cAMP-elevating agents inhibit neutrophil apoptosis⁴³. This finding may provide a possible explanation for the observed lack of effect of PDE4 inhibitors on neutrophil accumulation in some experimental situations (see Table 2).

Clinical prospects

A major concern that has arisen from the use of PDE4 inhibitors in clinical trials is the ability of these drugs to induce nausea and emetic side-effects⁴⁴. The mechanisms involved in the induction of these side-effects are poorly understood but, based on animal studies, the binding of inhibitors to the so-called rolipram high-affinity binding site is thought to be important (for a review on the high-affinity binding site, see Refs 45–47). Recently this has been addressed formally using a series of biarylcarboxylic acids and amides; a reduction in rolipram binding was associated with a corresponding reduction in emetic effects while anti-inflammatory

potency was maintained⁴⁸. These studies suggest that emetic side-effects can be overcome in clinical practice. However, there are other potential side-effects related to PDE4 inhibition, such as immunosuppression and metabolic disturbances (e.g. altered glucose metabolism; see below). Will chronic administration of PDE4 inhibitors be safer than chronic treatment with steroids or other immunosuppressive agents? Treatment with a PDE4 inhibitor significantly inhibited the *ex vivo* tumoricidal, but not the candidal, activity of macrophages and neutrophils⁴⁹. In addition, systemic treatment with the nonspecific PDE inhibitor theophylline significantly reduced pulmonary antibacterial defence in mice⁵⁰. Phosphodiesterase 4 inhibitors have also been shown to possess significant effects on the release and/or action of hormones such as renin and insulin (e.g. Refs 51–53). Whether *in vivo* treatment with PDE4 inhibitors will result in significant metabolic disturbance clearly deserves further investigation. Moreover, it is important to define the comparative efficacy of PDE4 inhibitors and steroids in different models of inflammation (e.g. Refs 9, 54). As reported with steroids, the effectiveness of PDE4 inhibitors as anti-inflammatory agents may parallel their ability to cause immunosuppression and this needs to be tested experimentally. Such information would help to clarify the indications and potential limitations of these drugs for use in clinical trials. Finally, the prototype PDE4 inhibitor rolipram was initially developed clinically for the treatment of depression⁴⁴. Further investigation is needed to determine whether other PDE4 inhibitors will cause significant CNS effects and whether these will limit their usefulness as anti-inflammatory agents.

Unanswered questions

Recently, it has become apparent that PDE4 is not just one enzyme but comprises a group of enzymes (PDE4 A–D) which are differentially regulated and expressed in different cells (reviewed in Ref. 45). In general, PDE4 inhibitors have little selectivity for PDE4 subtypes although most appear to be less potent against PDE4C compared with other subtypes⁴⁵. In addition, the expression of the PDE4D isoform is increased following short-term cAMP stimulation and inhibitors that display some specificity for the activated enzyme have been developed⁵⁵. Thus, there is a distinct possibility that the development of specific inhibitors of PDE4 subtypes will become available in the near future. When they do, it will be necessary to assess whether these agents are better than, or at least as effective as, 'nonspecific' PDE4 inhibitors and whether they will induce fewer side-effects.

It is now apparent that chronic activation of inflammatory cells with cAMP is associated with modulation of the activity and numbers of PDE4 isoenzymes. It consists of two regulatory processes: one is short term and involves protein phosphorylation; the other is long term and involves increased gene expression (reviewed in

Ref. 56). More importantly, this modulation of PDE4 isoenzymes is accompanied by a decreased ability of cAMP-elevating agents to inhibit inflammatory cell function and is reversed by rolipram, which suggests that the tolerant state is related to the expression or activity of PDE4 (Refs 57, 58). Interestingly, β_2 -adrenoceptor agonists are effective inducers of PDE4 isoenzymes and it is possible that prolonged use of β_2 -adrenoceptor agonists may lead to upregulation of PDE4 *in vivo* and the development of tolerance to the anti-inflammatory activities of these drugs⁵⁶. Prolonged inhibition of PDE4 may also lead to upregulation of PDE4 *in vivo* although this requires investigation. Increased expression of PDE4 could result in a state of dependence on PDE4 inhibitors in such a way that it would be difficult to stop patients using the drug. In one study, severe asthmatics that made prolonged use of theophylline could not be weaned off the drug⁵⁹. Clearly, further studies are needed to assess the effects of chronic treatment with PDE4 inhibitors and drug withdrawal in animal models and in the clinical setting. Nevertheless, in view of the capacity of PDE4 inhibitors to reverse tolerance *in vitro*, these drugs may restore responses to cAMP-elevating agents *in vivo*. Finally, atopic patients have increased levels of PDE4 activity when compared to normal individuals⁶⁰. Whether the enzyme(s) that are elevated in atopics are activated or subject to differential inhibition by PDE4 inhibitors is unknown (see Ref. 45).

Concluding remarks

There has been an enormous excitement, in both industry and academia, with the development of selective PDE4 inhibitors. These are efficacious anti-inflammatory agents in animal models with potential widespread use in diverse inflammatory diseases in humans. Obviously, the answer to whether PDE4 inhibitors will fulfil their promise will only become apparent when clinical trials with appropriate agents have been conducted and reported. No selective PDE4 inhibitors are currently marketed. A number have entered Phase I clinical testing, although most have been dropped subsequently, largely due to side-effects. At present there are two selective PDE4 inhibitors, RP73401 and SB207499, in Phase II clinical testing as anti-asthma agents, and one, LAS31025, further advanced in Phase III. Clinical data on these are eagerly awaited. Recently published data on CDP840 indicate some clinical efficacy⁶¹, although the level of activity was apparently not sufficient to encourage the continued development of this compound for asthma. Topical application of the PDE4 inhibitor CP80633 significantly reduced inflammation in skin lesions of atopic dermatitis patients⁶². Meanwhile, important questions regarding the mechanism of action *in vivo*, safety and continuous efficacy of PDE4 inhibitors when used chronically remain and should be addressed experimentally.

Selected references

- 1 Barnes, P. J. (1995) *New Engl. J. Med.* 332, 868–875
- 2 Nicholson, C. D., Challiss, R. A. J. and Shahid, M. (1991) *Trends Pharmacol. Sci.* 12, 19–27
- 3 Nicholson, C. D. and Shahid, M. (1994) *Pulm. Pharmacol.* 7, 1–17
- 4 Kammer, G. M. (1988) *Immunol. Today* 9, 222–229
- 5 Beavo, J. A., Conti, M. and Heaslip, R. J. (1994) *Mol. Pharmacol.* 46, 399–405
- 6 Djukanovic, R. et al. (1990) *Am. Rev. Respir. Dis.* 142, 434–457
- 7 Giembycz, M. A. and Kelly, J. J. (1994) in *Methylxanthines and Phosphodiesterase Inhibitors in the Treatment of Airways Disease*, (Costello, J. F. and Piper, P. J., eds), p. 27, Parthenon Press
- 8 Teixeira, M. M., Rossi, A. G., Williams, T. J. and Hellewell, P. G. (1994) *Br. J. Pharmacol.* 112, 332–340
- 9 Gozzard, N. et al. (1996) *Br. J. Pharmacol.* 118, 1201–1208
- 10 Howell, R. E., Jenkins, L. P. and Howell, D. E. (1995) *J. Pharmacol. Exp. Ther.* 275, 703–709
- 11 Sommer, N. et al. (1995) *Nat. Med.* 1, 244–248
- 12 Genain, C. P. et al. (1995) *Proc. Natl. Acad. Sci. U. S. A.* 92, 3601–3605
- 13 Jung, S. et al. (1996) *J. Neuroimmunol.* 68, 1–11
- 14 Entman, M. L. and Smith, C. W. (1994) *Cardiovasc. Res.* 28, 1301–1311
- 15 Brochert, G. et al. (1994) *Mol. Cell. Biochem.* 132, 57–67
- 16 Parratt, J. R. and Szekeres, L. (1995) *Trends Pharmacol. Sci.* 16, 351–355
- 17 Sekut, L. et al. (1995) *Clin. Exp. Immunol.* 100, 126–132
- 18 Tsuboi, Y. et al. (1996) *J. Clin. Invest.* 98, 262–270
- 19 Hulley, P. et al. (1995) *Eur. J. Neurosci.* 7, 2431–2440
- 20 Pettipher, E. R. et al. (1996) *Br. J. Pharmacol.* 117, 1530–1534
- 21 Prabhakar, U. et al. (1994) *Int. J. Immunopharmacol.* 16, 805–816
- 22 Turner, C. R., Esser, K. M. and Wheeldon, E. R. (1993) *Circ. Shock* 39, 237–245
- 23 Rabinovici, R. et al. (1996) *Circ. Res.* 78, 329–336
- 24 Turner, C. R., Andresen, C. J., Smith, W. B. and Watson, J. W. (1994) *Am. J. Respir. Crit. Care Med.* 149, 1153–1159
- 25 Griswold, D. E. et al. (1993) *Inflammation* 17, 333–343
- 26 Ortiz, J. L., Valles, J. M., Marti-Cabrera, M., Cortijo, J. and Morcillo, E. J. (1996) *Naunyn-Schmiedeberg's Arch. Pharmacol.* 353, 200–206
- 27 Kumari, M., Cover, P. O., Poyser, R. and Buckingham, J. (1994) *Br. J. Pharmacol.* 112, 163P
- 28 Hadley, A. J. et al. (1996) *Br. J. Pharmacol.* 119, 463–470
- 29 Hughes, B. et al. (1996) *Br. J. Pharmacol.* 118, 1183–1191
- 30 Miotla, J. M., Teixeira, M. M., Jeffery, P. K. and Hellewell, P. G. (1995) *Br. J. Pharmacol.* 116, 5P
- 31 Teixeira, M. M. and Hellewell, P. G. *Eur. J. Pharmacol.* (in press)
- 32 Kambayashi, T. et al. (1995) *J. Immunol.* 155, 4909–4916
- 33 Jilg, S. et al. (1996) *J. Pharmacol. Exp. Ther.* 278, 421–431
- 34 Pober, J. S., Slowik, M. R., De Luca, L. G. and Ritchie, A. J. (1993) *J. Immunol.* 150, 5114–5123
- 35 Morandini, R. et al. (1996) *Am. J. Physiol.* 270, H807–H816
- 36 Derian, C. K., Santulli, R. J., Rao, P. E., Solomon, H. F. and Barrett, J. A. (1995) *J. Immunol.* 154, 308–317
- 37 Teixeira, M. M., Rossi, A. G., Giembycz, M. A. and Hellewell, P. G. (1996) *Br. J. Pharmacol.* 118, 2099–2106
- 38 Cohen, J. J. (1993) *Immunol. Today* 14, 126–130
- 39 Teixeira, M. M., Williams, T. J. and Hellewell, P. G. (1995) *Trends Pharmacol. Sci.* 16, 418–423
- 40 Hallsworth, M. P., Giembycz, M. A., Barnes, P. J. and Lee, T. H. (1996) *Br. J. Pharmacol.* 117, 79–86
- 41 McConkey, D. J., Orrenius, S. and Jondal, M. (1990) *J. Immunol.* 145, 1227–1230
- 42 Lomo, J., Blomhoff, H. K., Beiske, K., Stokke, T. and Smeland, E. B. (1995) *J. Immunol.* 154, 1634–1643
- 43 Rossi, A. G. et al. (1995) *Biochem. Biophys. Res. Commun.* 217, 892–899
- 44 Zeller, E., Stief, H. J., Pflug, B., Sastre, Y. and Hernandez, M. (1988) *Pharmacopsychiatry* 59, 358–369
- 45 Muller, T., Engels, P. and Fozard, J. R. (1996) *Trends Pharmacol. Sci.* 17, 294–298
- 46 Kelly, J. J., Barnes, P. J. and Giembycz, M. A. (1996) *Biochem. J.* 318, 425–436
- 47 Jacobitz, S., McLaughlin, M. M., Livi, G. P., Burman, M. and Torphy, T. J. (1996) *Mol. Pharmacol.* 50, 891–899
- 48 Duplantier, A. J. et al. (1996) *J. Med. Chem.* 39, 120–125
- 49 Kaplan, J. M. et al. (1995) *Toxicology* 95, 186–196
- 50 Nelson, S., Sumner, W. R. and Jakab, G. J. (1985) *Am. Rev. Respir. Dis.* 131, 923–927
- 51 Parker, J. C., Van Volkenburg, M. A., Ketchum, R. J., Brayman, K. L. and Andrews, K. M. (1995) *Biochem. Biophys. Res. Commun.* 916, 923
- 52 Chiu, N., Park, I. and Reid, I. A. (1996) *J. Pharmacol. Exp. Ther.* 276, 1073–1077
- 53 Leibowitz, M. D. et al. (1995) *Diabetes* 44, 67–74
- 54 Klemm, P., Harris, H. J. and Perretti, M. (1995) *Eur. J. Pharmacol.* 281, 69–74
- 55 Alvarez, R. et al. (1995) *J. Pharmacol. Exp. Ther.* 48, 616–622
- 56 Giembycz, M. A. (1996) *Trends Pharmacol. Sci.* 17, 331–336
- 57 Torphy, T. J. et al. (1995) *J. Biol. Chem.* 270, 23598–23604
- 58 Koga, S. et al. (1995) *Am. J. Physiol.* 268, C1104–C1113
- 59 Nassif, E. G., Weinberger, M., Thompson, R. and Huntley, W. (1981) *New Engl. J. Med.* 304, 71–75
- 60 Chan, S. C., Reifsnnyder, D., Beavo, J. A. and Hanifin, J. M. (1993) *J. Allergy Clin. Immunol.* 91, 1179–1188
- 61 Harbinson, P. L. et al. (1996) *Am. J. Respir. Crit. Care Med.* 153, A346
- 62 Hanifin, J. M. et al. (1996) *J. Invest. Dermatol.* 107, 51–56
- 63 Giembycz, M. A. (1992) *Biochem. Pharmacol.* 43, 2041–2051
- 64 Simpson, P. J., Schelm, J. A., Smallwood, J. K., Clay, M. P. and Lindstrom, T. D. (1992) *J. Cardiovasc. Pharmacol.* 19, 987–995
- 65 Nielson, C. P., Vestal, R. E., Sturm, R. J. and Heaslip, R. (1990) *J. Allergy Clin. Immunol.* 86, 801–808
- 66 Dent, G., Giembycz, M. A., Rabe, K. F. and Barnes, P. J. (1991) *Br. J. Pharmacol.* 103, 1339–1346
- 67 Hatzelmann, A., Tenor, H. and Schudt, C. (1995) *Br. J. Pharmacol.* 114, 821–831
- 68 Souness, J. E. et al. (1991) *Biochem. Pharmacol.* 42, 937–945
- 69 Torphy, T. J. et al. (1992) in *Advances Second Messenger and Phosphoprotein Research*, (Strada, S. J. and Hidaka, H., eds), p. 289, Raven Press
- 70 Peachell, P. T. et al. (1992) *J. Immunol.* 148, 2503–2510
- 71 Kleine-Tebbe, J. et al. (1992) *Agents Actions* 36, 200–206
- 72 Giembycz, M. A., Corrigan, C. J., Seybold, J., Newton, R. and Barnes, P. J. (1996) *Br. J. Pharmacol.* 118,
- 73 Foissier, L., Lonchamp, M., Coge, F. and Canet, E. (1996) *J. Pharmacol. Exp. Ther.* 278, 1484–1490
- 74 Turner, N. C., Wood, L. J., Burns, F. M., Gueremy, T. and Souness, J. E. (1993) *Br. J. Pharmacol.* 108, 876–883
- 75 Verghese, M. W. et al. (1995) *J. Pharmacol. Exp. Ther.* 272, 1313–1320
- 76 Chini, C. C. S., Chini, E. N., Williams, J. M., Matousovich, K. and Dousa, T. P. (1994) *Kidney Int.* 46, 28–36
- 77 Matousovich, K., Grande, J. P., Chini, C. C. S., Chini, E. N. and Dousa, T. P. (1995) *J. Clin. Invest.* 96, 401–410
- 78 Suttrop, N., Weber, U., Welsch, T. and Schudt, C. (1993) *J. Clin. Invest.* 91, 1421–1428
- 79 Turner, C. R. et al. (1996) *J. Pharmacol. Exp. Ther.* 278, 1349–1355
- 80 Raeburn, D. and Karlsson, J.-A. (1993) *J. Pharmacol. Exp. Ther.* 267, 1147–1151
- 81 Ortiz, J. L., Cortijo, J., Valles, J. M., Bou, J. and Morcillo, E. J. (1993) *J. Pharm. Pharmacol.* 45, 1090–1092
- 82 Underwood, D. C. et al. (1993) *J. Pharmacol. Exp. Ther.* 266, 306–313
- 83 Santing, R. E., Olymulder, C. G., Van der Molen, K., Meurs, H. and Zaagsma, J. (1995) *Eur. J. Pharmacol.* 275, 75–82
- 84 Holbrook, M., Gozzard, N., James, T., Higgs, G. and Hughes, B. (1996) *Br. J. Pharmacol.* 118, 1192–1200
- 85 Banner, K. H. et al. (1995) *Pulm. Pharmacol.* 8, 37–42
- 86 Underwood, D. C. et al. (1994) *J. Pharmacol. Exp. Ther.* 270, 250–259
- 87 Lagente, V., Pruniaux, M.-P., Junien, J.-L. and Moodley, I. (1995) *Am. J. Respir. Crit. Care Med.* 151, 1720–1724
- 88 Banner, K. H. and Page, C. P. (1995) *Br. J. Pharmacol.* 114, 93–98
- 89 Lagente, V., Moodley, I., Perrin, S., Mottin, G. and Junien, J.-L. (1994) *Eur. J. Pharmacol.* 255, 253–256
- 90 Raeburn, D. et al. (1994) *Br. J. Pharmacol.* 113, 1423–1431
- 91 Elwood, W., Sun, J., Barnes, P. J., Giembycz, M. A. and Chung, K. F. (1995) *Inflamm. Res.* 44, 83–86
- 92 Gozzard, N. et al. (1996) *Br. J. Pharmacol.* 117, 1405–1412
- 93 Newsholme, S. J. and Schwartz, L. (1993) *Inflammation* 17, 25–31
- 94 Badger, A. M., Olivera, D. L. and Esser, K. M. (1994) *Circ. Shock* 44, 188–195
- 95 Fischer, W., Schudt, C. and Wendel, A. (1993) *Biochem. Pharmacol.* 45, 2399–2404
- 96 Cardelus, I., Gras, J., Jauregui, J., Llenas, J. and Palacios, J. M. (1996) *Eur. J. Pharmacol.* 299, 153–159
- 97 Sekut, L., Menius, J. A., Brackeen, M. F. and Connolly, K. M. (1994) *J. Lab. Clin. Med.* 124, 813–820
- 98 Begany, D. P., Carcillo, J. A., Herzer, W. A., Mi, Z. and Jackson, E. K. (1996) *J. Pharmacol. Exp. Ther.* 278, 37–41
- 99 Kips, J. C., Joos, G. F., Peleman, R. A. and Pauwels, R. A. (1993) *Clin. Exp. Allergy* 23, 518–523
- 100 Kato, H., Araki, T., Itoyama, Y. and Kogure, K. (1995) *Eur. J. Pharmacol.* 272, 107–110
- 101 Barnard, J. W. et al. (1994) *J. Appl. Physiol.* 77, 774–781



A comparison of the inhibitory activity of PDE4 inhibitors on leukocyte PDE4 activity *in vitro* and eosinophil trafficking *in vivo*

²Nicola Cooper, ³Mauro M. Teixeira, ²Julie Warneck, ¹Jadwiga M. Miotla, ²Ruth E. Wills, ¹David M.T. Macari, ⁴Robert W. Gristwood & ^{*}¹Paul G. Hellewell

¹Imperial College School of Medicine at the National Heart and Lung Institute, London SW3 6LY; ²Chiroscience Limited, Cambridge Science Park, Cambridge CB4 4WE; ³Departamento de Farmacologia, Universidade Federal de Minas Gerais, Belo Horizonte, MG 31290-901, Brazil and ⁴Stevenage Biosciences Ltd, Stevenage, SG2 8SD

1 Phosphodiesterase (PDE) 4 inhibitors have been shown to inhibit eosinophil PDE4 activity *in vitro* and accumulation of eosinophils in experimental airways inflammation. However, direct effects on eosinophil trafficking have not been studied in detail and it is not known if activity *in vitro* translates into efficacy *in vivo*. In the present study, we compared the activity of five PDE4 inhibitors *in vitro* and against trafficking of ¹¹¹In-eosinophils in cutaneous inflammation in the guinea-pig.

2 The rank order of potency for inhibition of PDE4 activity in guinea-pig eosinophil, neutrophil and macrophage, and human neutrophil lysates was RP73401 > SB207499 > CDP840 > rolipram > LAS31025. On TNF α production by human PBMC, all inhibitors with the exception of rolipram showed potency similar to their effect on neutrophil lysates.

3 In a brain cerebellum binding assay, the rank order of potency at displacing [³H]-rolipram was RP73401 > rolipram > SB207499 > CDP840 > LAS31025.

4 Trafficking of ¹¹¹In-eosinophils to skin sites injected with PAF, ZAP or antigen in sensitized sites was inhibited by oral administration of all PDE4 inhibitors. The rank order of potency was RP73401 = rolipram > LAS31025 > SB207499 > CDP840.

5 With the exception was RP73401, which was the most potent compound in all assays, there was no clear relationship between activity of PDE4 inhibitors *in vitro* and capacity to inhibit eosinophil trafficking *in vivo*. Thus, we conclude that *in vitro* activity of PDE4 inhibitors does not predict *in vivo* efficacy in an experimental model of eosinophil trafficking.

Keywords: Eosinophil; eosinophil trafficking; phosphodiesterase; phosphodiesterase 4 inhibitors; rolipram; RP73401; LAS31025; SB207499; CDP840

Abbreviations: PDE4, phosphodiesterase 4; ZAP, zymosan activated plasma

Introduction

Eosinophils are considered to have important effector functions in chronic allergic diseases such as asthma (Venge, 1990), rhinitis (Klementsson, 1992), dermatitis (Bruijnzeel-Koomen *et al.*, 1992) and conjunctivitis (Foster *et al.*, 1991). They are often the predominant leukocyte type in these diseases and through secretion of a cocktail of lipid and protein mediators are thought to modulate bronchial smooth muscle tone in the airways, cause oedema formation and influence the function of other cells (Martin *et al.*, 1996). Cationic proteins (e.g. major basic protein and eosinophil-cationic protein), stored in eosinophil granules and released upon activation, are important for host defence against parasites. Misdirected release of these proteins in allergic inflammation damages host epithelial cells thus contributing to disease pathology (Wardlaw *et al.*, 1988; Montefort *et al.*, 1992). Controlling accumulation and activation of eosinophils may offer therapeutic benefit in allergic diseases. However, a detailed understanding of the mechanisms underlying eosinophil accumulation *in vivo* is essential to the development of new and safe therapeutic strategies based on reduced recruitment of these cells (Teixeira *et al.*, 1995).

One strategy to control tissue eosinophilia and eosinophil activation is to increase intracellular levels of cyclic AMP in eosinophils and other cells that participate in the inflammatory process (Teixeira *et al.*, 1997). The intracellular levels of cyclic AMP are regulated by the rate of cyclic AMP production by receptor-coupled adenylate cyclase and the rate of cyclic AMP degradation by 3',5'-cyclic nucleotide phosphodiesterases (PDE). Seven distinct families of PDEs have been described based on genetic, biochemical and pharmacological data (Beavo *et al.*, 1994; Torphy, 1998). Of these families, PDE4 appears to be the most important for the regulation of cyclic AMP levels in eosinophils (Dent *et al.*, 1991; Souness *et al.*, 1991). In accordance with the importance of PDE4 for the control of cyclic AMP levels in eosinophils, inhibitors of this enzyme have been shown to raise cyclic AMP in eosinophils and suppress a range of functions, including the respiratory burst, enzyme release, chemotaxis, lipid mediator production, homotypic aggregation and elevation of intracellular Ca²⁺ (reviewed in Teixeira *et al.*, 1997; Torphy, 1998). Moreover, several structurally different inhibitors of PDE4 have been shown to inhibit the accumulation of eosinophils in a range of animal models of allergic inflammation (reviewed in Teixeira *et al.*, 1997). While a number of studies have compared the capacity of these structurally unrelated PDE4 inhibitors to inhibit leukocyte function *in vitro* (e.g. Barnette *et al.*, 1996), much less is known about the comparative efficacy and potency of PDE4 inhibitors on eosinophil trafficking *in vivo*.

*Author for correspondence at: Section of Medicine-Vascular Biology, Clinical Sciences Centre, Northern General Hospital, Sheffield, S5 7AU. E-mail: p.g.hellewell@sheffield.ac.uk

In guinea-pig skin, the intradermal injection of different known mediators of inflammation or of antigen, in sites previously sensitized with an antigen-specific (BGG) IgG₁-rich anti-serum (passive cutaneous anaphylaxis, PCA reaction), leads to a dose-dependent rapid recruitment of intravenously injected ¹¹¹In-labelled eosinophils (Faccioli *et al.*, 1991; Teixeira *et al.*, 1993a). In the PCA reaction, the mediators responsible for cell accumulation have not been fully characterized, but a 5-lipoxygenase product, probably LTB₄, appears to play an important role (Teixeira & Hellewell, 1994). The mechanism by which ¹¹¹In-eosinophils accumulate in guinea-pig skin has been demonstrated to be dependent on fucoidin-sensitive selectins and β_1 and β_2 integrins (Weg *et al.*, 1993; Teixeira *et al.*, 1994a; Teixeira & Hellewell, 1997b). In this model, the systemic (i.p. plus i.v.) administration of the PDE4 inhibitor rolipram, but not of inhibitors of PDE3 or PDE5, effectively suppressed the recruitment of eosinophils into inflamed skin sites (Teixeira *et al.*, 1994b).

The aim of the present study was to compare the capacity of five selective PDE4 inhibitors, rolipram, RP73401 (Raeburn *et al.*, 1994), SB207499 (Barnette *et al.*, 1998), LAS31025 (Beleta *et al.*, 1996) and CDP840 (Perry *et al.*, 1998) to modulate eosinophil trafficking in guinea-pig skin. As our earlier studies showed that rolipram had no effect on neutrophil trafficking in guinea-pig skin (despite abrogating eosinophil trafficking under similar conditions), we took the opportunity to re-examine the effects of these inhibitors on neutrophil accumulation. To determine whether activities of these compounds on PDE4 *in vitro* would predict activity *in vivo*, we first compared the ability of these drugs to inhibit human and guinea-pig PDE4 isoenzyme activity in whole cells and cell extracts.

Methods

Induction, harvesting and purification of guinea-pig eosinophils, neutrophils and macrophages

Eosinophils were elicited in the peritoneal cavity as described previously (Teixeira *et al.*, 1993a). Briefly, female guinea-pigs (Harlan, Bicester; 500–600 g) were treated with horse serum (1 ml i.p.) every other day for 2 weeks and the cells collected by peritoneal lavage with heparinized saline (10 iu ml⁻¹) 2 days after the last injection. The cells obtained were layered onto a discontinuous Percoll-HBSS (Ca²⁺- and Mg²⁺-free) gradient followed by centrifugation (1500 × g, 25 min at 20°C). Eosinophils (>95% pure, >98% viable as assessed by trypan blue exclusion) were collected from the 1.090/1.095 and 1.095/1.100 g ml⁻¹ density interfaces.

Neutrophils were elicited in the peritoneal cavity of female guinea-pigs (500–600 g) by the i.p. injection of 15 ml of a 5% (w v⁻¹) solution of casein as previously described (Teixeira *et al.*, 1993b). After 12 h, the animals were sacrificed and the peritoneal cavity washed with heparinized saline (10 iu ml⁻¹). The rest of the procedure was followed as described for the eosinophils. The cells were also collected from the 1.090/1.095 and 1.095/1.100 g ml⁻¹ interfaces. The purity of the preparation was greater than 98% and the rare contaminants were eosinophils and occasional mononuclear cells. Viability was greater than 98%.

Macrophages were elicited in the peritoneal cavity of male guinea-pigs (400–450 g) by a single i.p. injection of horse serum followed by lavage 7 days later. Cells were layered onto a discontinuous Percoll gradient and centrifuged at 1600 × g for 20 min at 20°C according to the method of Gartner (1980).

Macrophages, >98% pure, were collected from the 1.070/1.075 g ml⁻¹ interface.

Purification of human neutrophils

Buffy coats from human blood were obtained from the Blood Transfusion Service (Cambridge) and mixed with an equal volume of 3% dextran to allow sedimentation of red blood cells. The leukocyte rich supernatant was layered on to an equal volume of Ficoll and centrifuged at 1000 × g for 30 min at 20°C. Neutrophils (>95% pure) were recovered in the pellet and remaining red cells were lysed using ammonium chloride lysis buffer (in mM: NH₄Cl₂ 155, KHCO₃ 10 and EDTA 0.1).

Preparation of cell lysates

Neutrophils, eosinophils or macrophages were lysed for 30 min on ice at a concentration of 3.2 × 10⁷ cell ml⁻¹ in solution containing 70% lysis buffer (in mM: MOPS 10, EGTA 1, magnesium acetate 1 and dithiothreitol 5, pH 7.4) and 30% ethylene glycol. Cell lysates were stored at -80°C.

Measurement of cyclic AMP PDE activity

PDE4 activity of cell lysates was assayed using a high throughput variation of the method of Thompson *et al.* (1979). The reaction is based on the breakdown of [³H]-cyclic AMP by PDE4 to the corresponding 5'-monophosphate, which is subsequently dephosphorylated by snake venom nucleotidase (*Ophiphagus hannah*).

The assay was carried out in 96-well Millipore filtration plates (Durapore, Millipore Ltd., Watford, Herts, U.K.) that were prewashed in ice cold 0.9% saline. The reaction was buffered to pH 7.5 in Tris-HCl (80 mM), MgCl₂ (20 mM), mercaptoethanol (12 mM) and 10 mg ml⁻¹ BSA and each well contained the following: [³H]-cyclic AMP (approximately 30,000 c.p.m.), cyclic AMP (12.5 pmol) and 10 μg nucleotidase. The reaction was started by the addition of 10 μl cell lysate to produce 10–20% substrate hydrolysis. PDE4 inhibitors were solubilized in DMSO, diluted in assay buffer and added to duplicate wells at a range of concentrations (final DMSO concentration 0.5%). Plates were incubated for 30 min at 30°C and the reaction terminated by addition of 80 μl 30% Dowex AX resin. After mixing, the plates were filtered on a Millipore filtration system and the supernatants collected into a 96-well optiplate. Two hundred μl Microscint 40 (Canberra Packard, Pangbourne) was added to each well, plates sealed,

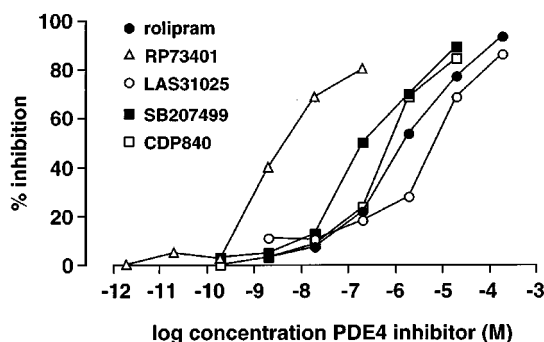

Figure 1 Inhibition of PDE4 activity in lysates of guinea-pig eosinophils by PDE4 inhibitors. Values are means of at least five different experiments. For clarity, error bars have been omitted.

mixed and counted on a Packard TopCount scintillation counter (Canberra Packard).

TNF α production by peripheral blood mononuclear cells

Human peripheral blood mononuclear cells (PBMC) were isolated from buffy coats by centrifugation on a density gradient of Ficoll-Paque. PBMC were harvested, washed three times, resuspended at 2×10^6 cell ml^{-1} in RPMI 1640 medium containing 2% FBS and plated in 48-well tissue culture plates. PDE4 inhibitors were solubilized in DMSO, diluted in RPMI and added to duplicate wells at a range of concentrations (final DMSO concentration 0.5%). Cells were stimulated with lipopolysaccharide at a final concentration of 100 ng ml^{-1} and incubated for 22 h at 37°C in an atmosphere of 5% CO_2 and 95% air. Cells were pelleted by centrifugation and TNF α in the supernatant assayed using ELISA (R&D Systems, Abingdon). Cell viability was not significantly affected by any of the PDE4 inhibitors when tested up to five times their IC_{50} concentrations (data not shown). The concentration of TNF α in control supernatants was below detection limits and in supernatants from LPS stimulated cells was 2.59 ± 0.5 ng ml^{-1} ($n=3$).

Rolipram binding assay

Rat brain membranes were used as a source of high affinity rolipram binding protein (RBP). The binding assay was a high throughput version based upon a method described by

Schneider *et al.* (1986). Briefly, assay buffer (in mM: Tris-HCl 20, MgCl_2 2, dithiothreitol 0.1, pH 7.5). PDE4 inhibitor and [^3H]-rolipram (approximately 300,000 d.p.m.) were pipetted into 96-well Millipore microtitre plates. One hour after addition of RBP (100 μg per well), reactions were terminated by filtration (Millipore), filtered protein washed and dried followed by addition of Microscint 0 and counting on a Packard TopCount scintillation counter.

Radiolabelling of guinea-pig eosinophils and neutrophils for in vivo trafficking studies

The purified eosinophils and neutrophils were radiolabelled by incubation with $^{111}\text{InCl}_3$ (100 μCi in 10 μl) chelated to 2-mercaptopyridine-N-oxide (40 μg in 0.1 ml of 50 mM PBS, pH 7.4) for 15 min at room temperature. The cells were then washed twice in HBSS (calcium- and magnesium-free) containing 10% guinea-pig platelet-poor plasma and resuspended at a final concentration of 10^7 cells ml^{-1} prior to injection.

Preparation of zymosan-activated plasma

Zymosan-activated plasma (ZAP) was used as a source of guinea-pig C5a des Arg. Guinea-pig heparinized (10 iu ml^{-1}) plasma was incubated with zymosan (5 mg ml^{-1}) at 37°C. After 30 min, zymosan was removed by centrifugation (2×10 min at $3000 \times g$) and the ZAP stored in aliquots at -20°C .

Table 1 Comparison of the ability of PDE4 inhibitors to suppress PDE4 activity *in vitro*

	Guinea-pig eosinophil (IC_{50})	Guinea-pig neutrophil (IC_{50})	Guinea-pig macrophage (IC_{50})	Human neutrophil (IC_{50})	Human PBMC TNF α (IC_{50})	Rat brain binding (IC_{50})
Rolipram ($\times 10^{-6}$ M)	2.42 ± 0.48 (7)	0.56, 1.17 (2)	4.55 ± 0.80 (8)	4.52 ± 1.55 (5)	0.16 ± 0.07 (3)	0.05 ± 0.02 (>6)
RP73401 ($\times 10^{-9}$ M)	4.82 ± 0.82 (6)	3.15 ± 0.46 (3)	2.24 ± 0.42 (6)	1.33 ± 0.65 (4)	0.51 ± 0.02 (3)	3.07 ± 0.92 (>6)
LAS31025 ($\times 10^{-6}$ M)	15.05 ± 3.84 (5)	6.3, 14.1 (2)	9.01 ± 2.69 (6)	6.76 ± 2.86 (5)	2.00 ± 0.50 (3)	0.75 ± 0.21 (>6)
SB207499 ($\times 10^{-6}$ M)	0.23 ± 0.07 (6)	0.06 ± 0.01 (3)	0.21 ± 0.04 (6)	0.11 ± 0.01 (4)	0.14 ± 0.02 (3)	0.07 ± 0.03 (>6)
CDP840 ($\times 10^{-6}$ M)	0.67 ± 0.18 (7)	0.65, 0.94 (2)	0.36 ± 0.09 (6)	0.18 ± 0.05 (3)	0.17 ± 0.07 (4)	0.25 ± 0.12 (>6)

Values shown are IC_{50} expressed as 10^{-6} M with the exception of RP73401 which are shown as 10^{-9} M. Data is expressed as mean \pm s.e.mean except where $n=2$ and individual values are shown. The number of experiments is shown in parentheses.

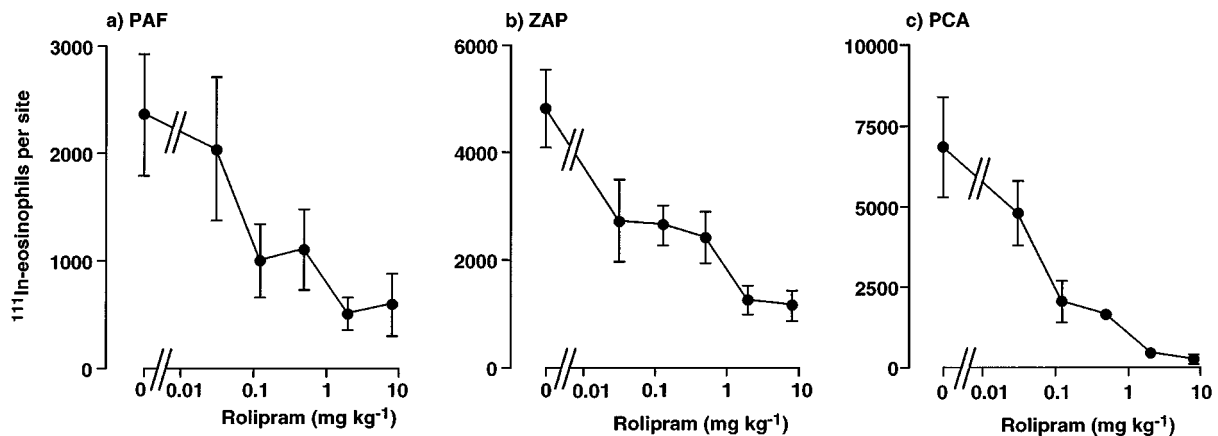

Figure 2 Effect of oral administration of rolipram on the trafficking of ^{111}In -eosinophils to skin sites injected with PAF, ZAP or in the PCA reaction. Rolipram was administered p.o. 1 h before i.v. injection of ^{111}In -eosinophils and i.d. injection of PAF (1 nmol), ZAP (30%) or antigen (1 μg BGG, shown as PCA). Accumulation of ^{111}In -eosinophils in sites was assessed after 1 h. Values are mean \pm s.e.mean of experiments in 3–10 animals at each dose and have been subtracted for saline values (189 ± 22 ^{111}In -eosinophils per site).

Preparation of passive cutaneous anaphylaxis sera and reactions

Details of the preparation of sera and doses of antigen are described elsewhere (Weg *et al.*, 1991). Briefly, male guinea-pigs (Harlan, Oxon; 350–400 g) were immunized with bovine gamma-globulin (BGG) in Freund's complete adjuvant followed by a boost on day 21 and serum collected on day 30. Recipient animals received an i.d. injection of 50 μ l of a 1/50 dilution of the anti-serum followed, 16–20 h later, by the injection of antigen (BGG, 0.01–1 μ g per site). Most of the tissue-fixing antibody was of the IgG₁ isotype (Weg *et al.*, 1991).

Measurement of leukocyte trafficking in guinea-pig skin

Radiolabelled eosinophils or neutrophils were injected i.v. (2.5×10^6 cells per animal) into recipient guinea-pigs (Harlan; 350–400 g) sedated with Hypnorm. PDE4 inhibitors were solubilized in 10% DMSO ($v v^{-1}$ in sterile water) and administered by oral gavage. Fifty-five minutes later, radiolabelled leukocytes were injected i.v. *via* an ear vein and, 5 min after this, inflammatory mediators or antigen were injected i.d. in 0.1 ml volumes into the dorsal skin of the shaved animals. Thus, the total time between oral administration and induction of cutaneous inflammation was 1 h. Each animal received a duplicate of each i.d. treatment following a randomized injection plan and ¹¹¹In-labelled cell accumulation was assessed after 1 h. At this time, blood was obtained by cardiac puncture and the animals were sacrificed by an overdose of sodium pentobarbitone. The dorsal skin was removed, cleaned free of excess blood and the skin sites punched out with a 17 mm punch. The samples were counted in an automatic 5-head gamma-counter (Canberra Packard) and the number of leukocyte accumulating in each site expressed as ¹¹¹In-labelled cells per skin site.

Reagents

The following compounds were purchased from Sigma Chemical Company (Poole, Dorset, U.K.): 2-mercaptopyridine-N-oxide, DMSO, casein, bovine gamma globulin (BGG), dithiothreitol, ethylene glycol, Freund's complete adjuvant,

zymosan, cyclic AMP and snake venom (*Ophiphagus hannah*). Hanks solutions, HEPES and horse serum were purchased from Life Technologies Limited (Paisley, Scotland). Dextran, Ficoll, Ficoll-Paque and Percoll were from Pharmacia (Milton Keynes, Bucks, U.K.) and C16 PAF from Bachem (Saffron Walden, Essex, U.K.). ¹¹¹InCl₃ and [³H]-cyclic AMP (25 Ci mmol⁻¹), [*methyl*-³H]-rolipram (21 Ci mmol⁻¹) and ¹¹¹InCl₃ were purchased from Amersham International plc, Amersham. The following selective PDE4 isoenzyme inhibitors were synthesized by the Chemistry Department at Chiroscience: rolipram [4-(3-cyclopentyloxy-4-methoxyphenyl)-2-pyrrolidinone], RP73401 [N-(3,5-dichloropyrid-4-yl)-3-cyclopentyloxy-4-methoxybenzamide] (Raeburn *et al.*, 1994), LAS31025 [1-propyl-3-(4-chlorophenyl)-xanthine] (Beleta *et al.*, 1996), SB207499 [c-4-cyano-4-(3-cyclopentyloxy-4-methoxyphenyl)-r-1-cyclohexanecarboxylic acid] (Barnette *et al.*, 1998) and the sulphate salt of CDP840 (R-[+]-4-[2-3-cyclopentyloxy-4-methoxyphenyl-2-phenylethyl]pyridine) Perry *et al.*, 1998).

Table 2 IC₅₀ values for inhibition of ¹¹¹In-eosinophil recruitment in guinea-pig skin by oral administration of PDE4 inhibitors

	Inflammatory stimulus					
	PAF		ZAP		PCA	
	0.1 (IC ₅₀ mg kg ⁻¹)	1 (IC ₅₀ mg kg ⁻¹)	10 (IC ₅₀ mg kg ⁻¹)	30 (IC ₅₀ mg kg ⁻¹)	0.1 (IC ₅₀ mg kg ⁻¹)	1 (IC ₅₀ mg kg ⁻¹)
Rolipram	0.04	0.1	0.06	0.1	0.08	0.06
RP73401	0.03	0.1	0.05	0.09	0.06	0.05
LAS31025	0.9	2	2	3	2	2
SB207499	8	24	13	18	6	7
CDP840	4	26	>32	>32	7	7

Animals were dosed orally with PDE4 inhibitors 1 h prior to i.v. injection of ¹¹¹In-eosinophils and i.d. injection of PAF (0.1 and 1 nmol per site), ZAP (10 and 30% per site) and antigen (0.1 and 1 μ g BGG per site; shown as PCA). Accumulation of ¹¹¹In-eosinophils in skin sites was assessed after 1 h and mean IC₅₀ values calculated from data obtained in 3–6 animals at each dose. The numbers (given as a range) of ¹¹¹In-eosinophils accumulating at skin sites in vehicle-treated guinea-pigs were as follows: saline, 180–240; PAF 0.1, 783–1514; PAF 1, 2389–3449; ZAP 10, 1721–2304; ZAP 30, 4662–6354; PCA 0.1, 4290–7302; PCA 1, 6719–11623.

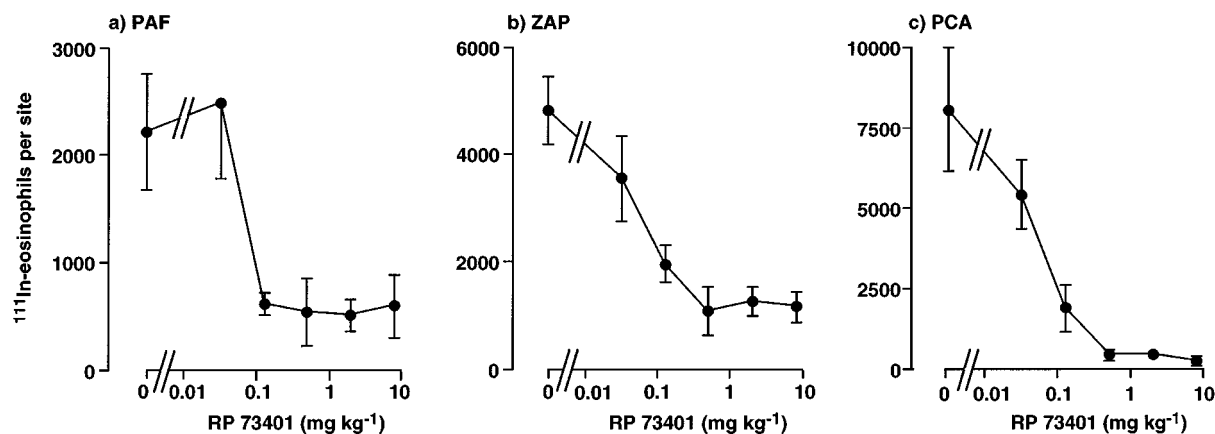

Figure 3 Effect of oral administration of RP73401 on the trafficking of ¹¹¹In-eosinophils to skin sites injected with PAF, ZAP or in the PCA reaction. RP73401 was administered p.o. 1 h before i.v. injection of ¹¹¹In-eosinophils and i.d. injection of PAF (1 nmol), ZAP (30%) or antigen (1 μ g BGG, shown as PCA). Accumulation of ¹¹¹In-eosinophils in sites was assessed after 1 h. Values are mean \pm s.e. mean of experiments in 3–9 animals at each dose and have been subtracted for saline values (180 ± 20 ¹¹¹In-eosinophils per site).

Statistical analysis

For the neutrophil experiments, results were compared using analysis of variance and *P* values assigned using Student-Newman-Keuls (Instat Software). Per cent inhibition was calculated after subtracting background (saline) values. Results were presented as the mean \pm s.e. mean for the number of animals given and were considered significant when *P* < 0.05.

Results

Effects of PDE4 inhibitors on guinea-pig and human leukocyte PDE4 activity

Before conducting the *in vivo* studies, we wished to confirm the activity of the PDE4 inhibitors against guinea-pig and, for comparison, human PDE4 in whole cells and cell lysates. Figure 1 shows the dose-inhibition curves for all five compounds on the PDE4 activity isolated from guinea-pig eosinophils. Whereas all agents almost abrogated guinea-pig

eosinophil PDE4 activity at the highest concentrations tested, RP73401 was the most potent. The rank order of potency for inhibition of the guinea-pig eosinophil PDE4 activity was RP73401 > SB207499 > CDP840 > rolipram > LAS31025 (Table 1). A similar rank order of potency for inhibition of PDE4 was observed when these compounds were tested against the enzyme activity in lysates of guinea-pig neutrophils and macrophages (Table 1).

On human neutrophil lysates, the compounds also inhibited PDE4 activity with a similar rank order of potency to that seen with guinea-pig cells (Table 1). When tested against TNF α production by human PBMC, all inhibitors with the exception of rolipram showed potency similar to their effect on neutrophil lysates (Table 1). In contrast, rolipram was approximately 30 times more potent as an inhibitor of TNF α production by PBMC than it was as an inhibitor of enzyme activity in neutrophil lysates.

Rolipram binding assay

In our hands, RP73401 was the most potent in this assay and was approximately 10 fold more potent than rolipram.

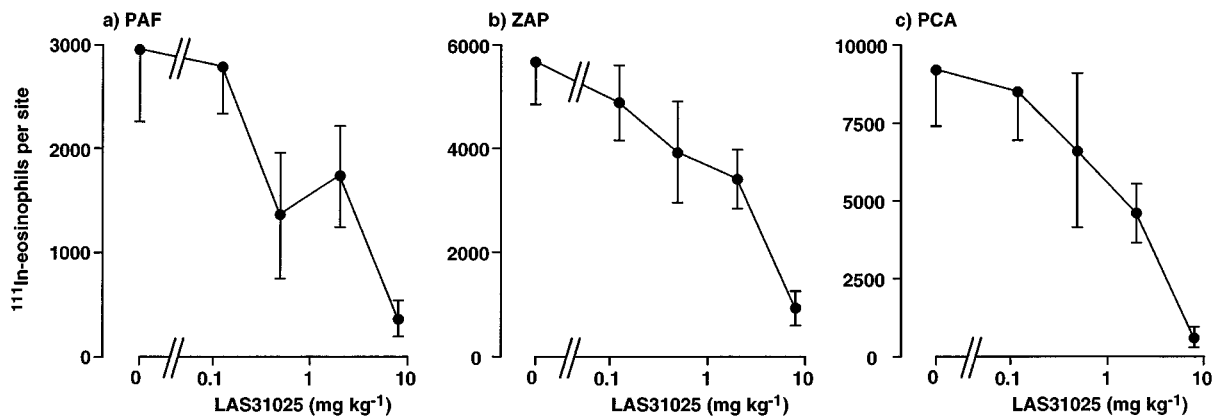

Figure 4 Effect of oral administration of LAS31025 on the trafficking of ¹¹¹In-eosinophils to skin sites injected with PAF, ZAP or in the PCA reaction. LAS31025 was administered p.o. 1 h before i.v. injection of ¹¹¹In-eosinophils and i.d. injection of PAF (1 nmol), ZAP (30%) or antigen (1 μ g BGG, shown as PCA). Accumulation of ¹¹¹In-eosinophils in sites was assessed after 1 h. Values are mean \pm s.e. mean of experiments in 4–7 animals at each dose and have been subtracted for saline values (240 ± 46 ¹¹¹In-eosinophils per site).

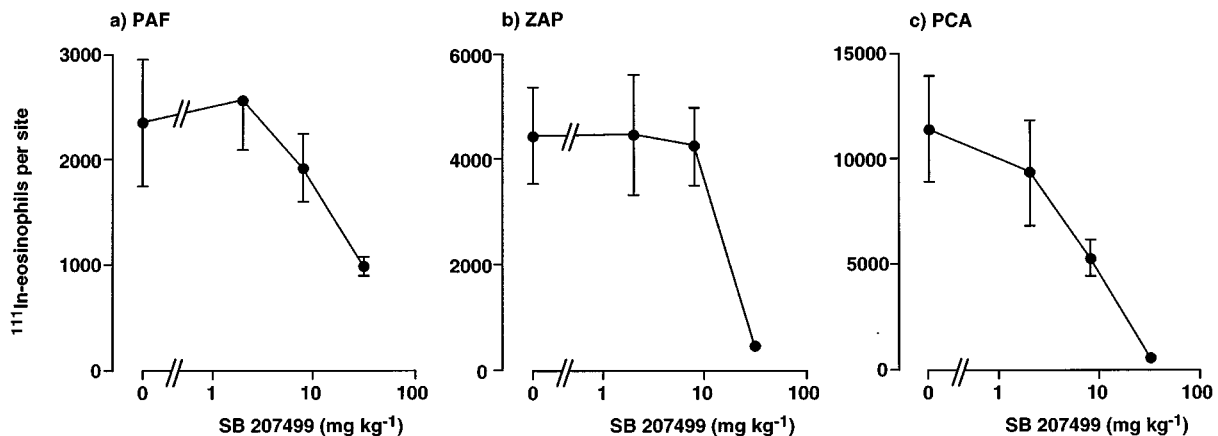

Figure 5 Effect of oral administration of SB207499 on the trafficking of ¹¹¹In-eosinophils to skin sites injected with PAF, ZAP or in the PCA reaction. SB207499 was administered p.o. 1 h before i.v. injection of ¹¹¹In-eosinophils and i.d. injection of PAF (1 nmol), ZAP (30%) or antigen (1 μ g BGG, shown as PCA). Accumulation of ¹¹¹In-eosinophils in sites was assessed after 1 h. Values are mean \pm s.e. mean of experiments in 4–6 animals at each dose and have been subtracted for saline values (233 ± 58 ¹¹¹In-eosinophils per site).

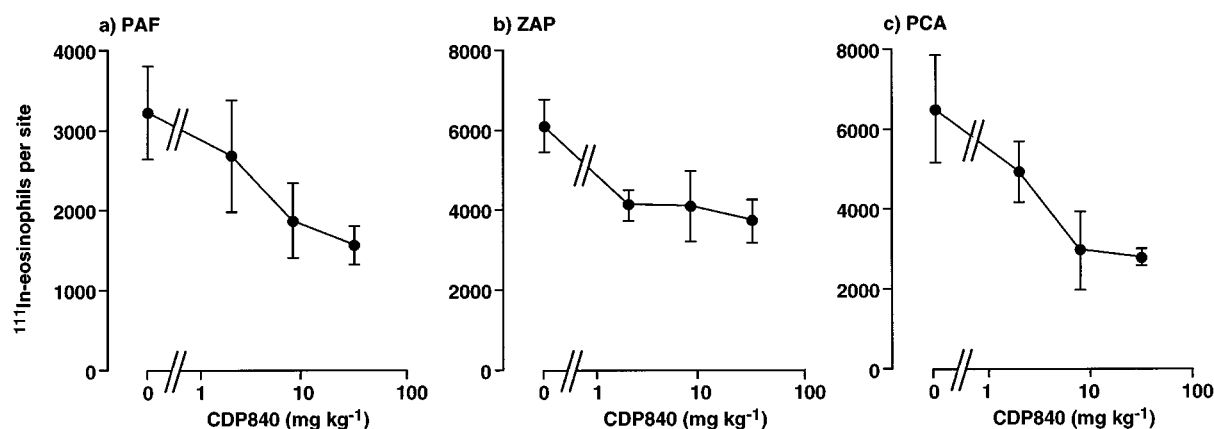

Figure 6 Effect of oral administration of CDP840 on the trafficking of ^{111}In -eosinophils to skin sites injected with PAF, ZAP or in the PCA reaction. CDP840 was administered p.o. 1 h before i.v. injection of ^{111}In -eosinophils and i.d. injection of PAF (1 nmol), ZAP (30%) or antigen (1 μg BGG, shown as PCA). Accumulation of ^{111}In -eosinophils in sites was assessed after 1 h. Values are mean \pm s.e. mean of experiments in 4–6 animals at each dose and have been subtracted for saline values (239 ± 33 ^{111}In -eosinophils per site).

Table 3 Effect of oral administration of PDE4 inhibitors on ^{111}In -neutrophil recruitment in guinea-pig skin

	Vehicle	^{111}In -neutrophils per skin site				
		Rolipram 2 mg kg ⁻¹	RP73401 2 mg kg ⁻¹	LAS31025 8 mg kg ⁻¹	SB207499 32 mg kg ⁻¹	CDP840 32 mg kg ⁻¹
Saline	84 \pm 11	66 \pm 4	57 \pm 16	88 \pm 29	88 \pm 8	66 \pm 9
PAF 0.1	334 \pm 84	176 \pm 31	250 \pm 38	247 \pm 49	269 \pm 49	305 \pm 24
PAF 1.0	480 \pm 120	325 \pm 16	400 \pm 53	391 \pm 92	377 \pm 40	377 \pm 59
ZAP 10%	1190 \pm 312	692 \pm 101	872 \pm 160	636 \pm 117	902 \pm 161	862 \pm 129
ZAP 30%	1803 \pm 476	965 \pm 134	1368 \pm 142	919 \pm 233	1365 \pm 216	1145 \pm 181
PCA 0.1	664 \pm 161	652 \pm 346	437 \pm 75	534 \pm 190	657 \pm 257	446 \pm 143
PCA 1.0	789 \pm 172	715 \pm 404	477 \pm 138	582 \pm 233	756 \pm 213	605 \pm 204

Animals were dosed p.o. at the doses shown with PDE4 inhibitors 1 h prior to i.v. injection of ^{111}In -neutrophils and i.d. injection of PAF (0.1 and 1 nmol per site), ZAP (10 and 30% per site) and antigen (0.1 and 1 μg BGG per site; shown as PCA). Accumulation of ^{111}In -neutrophils in skin sites was assessed after 1 h. Values are mean \pm s.e. mean of 3–4 experiments with each compound and eight experiments for vehicle-treated animals.

SB207499 showed similar potency to rolipram, CDP840 was 5 fold less potent than rolipram and LAS30125 was the least potent.

Effects of PDE4 inhibitors on eosinophil trafficking in guinea-pig skin

We have previously shown that systemic treatment with rolipram (5 mg kg⁻¹ i.p. plus 0.5 mg kg⁻¹ i.v.), but not with PDE3 or PDE5 inhibitors, effectively inhibited ^{111}In -eosinophil recruitment induced by several inflammatory mediators and in a PCA reaction in guinea-pig skin (Teixeira *et al.*, 1994b). In the present study, oral treatment with rolipram effectively and dose-dependently inhibited ^{111}In -eosinophil recruitment induced by PAF (10⁻⁹ mol per site), ZAP (30%) and in the PCA reaction (1 μg of BGG per site) (Figure 2). Maximal inhibition of ^{111}In -eosinophil recruitment was achieved at a dose of 2 mg kg⁻¹ of rolipram such that the response in the PCA reaction was virtually abolished (Figure 2). The IC₅₀ values (mg kg⁻¹) for inhibition of ^{111}In -eosinophil recruitment induced by PAF, ZAP and in the PCA reaction in guinea-pig skin by oral treatment with rolipram are shown in Table 2.

Figure 3 shows the effects of oral administration of RP73401 on ^{111}In -eosinophil recruitment in guinea-pig skin. As found with rolipram, RP73401 abrogated ^{111}In -eosinophil

recruitment induced by PAF and ZAP and in the PCA reaction. Inhibition was maximal at 0.5 mg kg⁻¹ and, similarly to the effects of rolipram, the trafficking of radiolabelled eosinophils in the PCA reaction was virtually abolished (Figure 3). RP73401 was of similar potency to rolipram but substantially more potent than the other PDE4 inhibitors tested (Table 2). Both LAS31025 (Figure 4) and SB207499 (Figure 5) abolished ^{111}In -eosinophil recruitment in the PCA reaction in guinea-pig skin at the highest doses tested (8 and 32 mg kg⁻¹, respectively). The ^{111}In -eosinophil recruitment induced by PAF and ZAP was also effectively inhibited, although the maximum inhibition by SB207499 of the response to PAF (10⁻⁹ mol per site) was 58% (Figure 5).

In contrast to the inhibitory effects of the PDE4 inhibitors described above, CDP840 only partially inhibited the ^{111}In -eosinophil recruitment in the PCA reaction (maximal inhibition was 57% at 32 mg kg⁻¹) (Figure 6). Moreover, the maximal inhibition of ZAP- and PAF-induced was 39 and 52%, respectively (Figure 6). Of the compounds tested, CDP840 was the least potent and the least effective (Figure 6 and Table 2).

Thus, the overall rank order of potency for inhibition of ^{111}In -eosinophil recruitment in guinea-pig skin by oral administration of PDE4 inhibitors was RP73401 = rolipram > LAS31025 > SB207499 \geq CDP840. In addition, eosinophil

trafficking in the PCA reaction was inhibited to a greater extent than were responses to PAF and ZAP. No toxic effects of compounds were observed over the 2 h duration of the experiments.

Effects of PDE4 inhibitors on neutrophil trafficking in guinea-pig skin

In contrast to its marked inhibitory effect on ^{111}In -eosinophil recruitment in guinea-pig skin, we have previously reported that rolipram failed to suppress the ^{111}In -neutrophil recruitment induced by several inflammatory mediators and in a PCA reaction (Teixeira *et al.*, 1994b). Table 3 shows the effects of rolipram, RP73401, LAS31205, SB207499 and CDP840 on ^{111}In -neutrophil recruitment induced by PAF, ZAP and in the PCA reaction in guinea-pig skin. The doses of the drugs used were chosen based on their ability to inhibit maximally the ^{111}In -eosinophil recruitment induced by the same mediators. At these doses, none of the drugs had any significant effect on the recruitment of ^{111}In -neutrophil induced any of the stimuli used (Table 3).

Discussion

There has been much interest in the development of PDE4 inhibitors for the treatment of allergic diseases, especially asthma. In laboratory animals these drugs have potent anti-inflammatory effects under diverse situations and, in the context of allergic diseases, have been shown to inhibit recruitment and function of eosinophils and other leukocytes and the release and action of several inflammatory mediators and cytokines (Teixeira *et al.*, 1997; Torphy, 1998). In addition, in the context of asthma, inhibitors of PDE4 may act synergistically with β_2 -adrenoceptor agonists to induce significant bronchodilation (Giembycz & Dent, 1992). In the present study, we have evaluated the effects of five structurally different inhibitors of PDE4 (rolipram, RP73401, SB207499, CDP840 and LAS31205) for their ability to suppress PDE4 activity *in vitro* and eosinophil and neutrophil trafficking *in vivo*. In contrast to other studies that have evaluated the effects of PDE4 inhibitors on eosinophil migration in lung models where PDE4 inhibitors may affect eosinophil migration indirectly (for example by effects on T cells or macrophages), here we are addressing the effects of these drugs on eosinophil trafficking directly.

Rolipram appears to bind to purified PDE4 with two distinct affinities; a binding site to which rolipram has μM affinity and one to which rolipram has nM affinity. The former is usually referred to as the PDE4 catalytic site and the latter as the 'rolipram-binding site'. Recently, it has been proposed that these two sites represent different conformational states of PDE4; LPDE4 is the conformer to which rolipram binds with low affinity and HPDE4 is the conformer to which rolipram binds with high affinity (Barnette *et al.*, 1995b; Jacobitz *et al.*, 1996; Kelly *et al.*, 1996). All five PDE4 inhibitors tested here completely suppressed the catalytic activity of the enzyme obtained from leukocytes with the following rank order of potency: RP73401 > SB207499 > CDP840 > rolipram > LAS31205. We also tested the ability of these drugs to interact with the HPDE4 in rat cerebellum. The rank order of potency for inhibition in this assay was RP73401 > rolipram > SB207499 > CDP840 > LAS31205.

Several studies have shown that the ability of PDE4 inhibitors to interact with LPDE4 usually correlates with the ability of these drugs to inhibit several leukocyte functions *in*

vitro (Barnette *et al.*, 1995b; 1996; 1998). For example, in guinea-pig eosinophils, the ability of PDE4 inhibitors to suppress superoxide production *in vitro* correlates with inhibition of the catalytic activity of PDE4 isolated from these cells (Barnette *et al.*, 1995b). In the present study, we found that inhibition of TNF α production by LPS-stimulated PBMC also correlates with inhibition of PDE4 catalytic activity (see Table 1). In contrast, there is a poor correlation between the ability of PDE4 inhibitors to suppress some leukocyte functions and their ability to bind to the HPDE4 (Barnette *et al.*, 1996). The capacity of PDE4 inhibitors to have anti-inflammatory activity has therefore been attributed to inhibition of LPDE4 while side effects have been attributed to binding to HPDE4 (Barnette *et al.*, 1995a; Duplantier *et al.*, 1996). The importance of these different conformational states of the enzyme to the anti-inflammatory activity of PDE4 inhibitors *in vivo* is not yet known. Here, we have tested a range of structurally unrelated PDE4 inhibitors given orally for their ability to suppress eosinophil trafficking in guinea-pig skin. Oral treatment with all five PDE4 inhibitors reduced eosinophil recruitment with the following rank order of potency RP73401 = rolipram > LAS31205 > SB207499 > CDP840. There was a poor correlation between inhibition of eosinophil trafficking in guinea-pig skin and inhibition of the LPDE4 (see Tables 1 and 2). In addition, inhibition of PDE4 in whole cells (PBMC) did not predict *in vivo* activity. There was also a poor correlation between inhibition of eosinophil trafficking and binding of PDE4 inhibitors to HPDE4. The exception was RP73401 that showed highest potency against LPDE4, HPDE4 and *in vivo*. Despite the range of potencies, all inhibitors displayed similar efficacy *in vitro* (see Figure 1) but this did not necessarily translate into effectiveness *in vivo*. Thus, while rolipram, RP73401, LAS31205 and SB207499 inhibited ^{111}In -eosinophil trafficking by a maximum of 92–98%, the maximum inhibition achieved by CDP840 was 59%. Inasmuch as the drugs were given by the oral route, the pharmacokinetic characteristics of each compound (absorption, distribution, half-life) may have significantly affected their capacity to inhibit eosinophil trafficking *in vivo*. Our studies suggest that *in vitro* activity on cell lysates or whole cells (at least human PBMC) is not a reliable predictor of potency or effectiveness *in vivo*.

The mechanisms by which inhibitors of PDE4 suppress the trafficking of eosinophils in guinea-pig skin are not entirely known. We have previously suggested that several cellular sites of action could account for the inhibitory effects on eosinophil recruitment *in vivo* (Teixeira *et al.*, 1994b). The possibility that mast cells were the main cellular target for the inhibitory action of rolipram was raised based on the ability of rolipram to inhibit ^{111}In -eosinophil recruitment in a PCA reaction to a greater extent than in response to direct-acting mediators (Teixeira *et al.*, 1994b). This finding was repeated in the present study, as was the lack of effect of PDE4 inhibitors on ^{111}In -neutrophil trafficking (see Table 3) and oedema formation (data not shown) in the PCA reaction. Thus, while inhibition of mast cells has a minor contribution to the inhibition of ^{111}In -eosinophil trafficking observed, mast cells do not appear to be the main cellular target for the inhibitory actions of PDE4 inhibitors in our model.

Inhibition of endothelial cell adhesion molecule expression at skin sites could also explain the ability of PDE4 inhibitors to suppress ^{111}In -eosinophil trafficking *in vivo*. For example, these drugs could inhibit the expression of the VLA-4 ligand VCAM-1 in skin sites as has been demonstrated *in vitro* (Blease *et al.*, 1998). Inasmuch as VLA-4 appears to be important for eosinophil, but not neutrophil, recruitment in guinea-pig skin

(Weg *et al.*, 1993), inhibition of the expression of VCAM-1 by PDE4 inhibitors could explain our observations on leukocyte recruitment. However, ^{111}In -eosinophil trafficking induced by PAF, ZAP or antigen in sensitized skin is rapid (Faccioli *et al.*, 1991) and protein-synthesis independent (Teixeira *et al.*, 1996) and is, therefore, unlikely to rely on the upregulation of VCAM-1. Another cellular target for PDE4 inhibitors is the eosinophil itself. We have shown that pretreatment of eosinophils with salmeterol significantly inhibited the trafficking of ^{111}In -eosinophils in guinea-pig skin (Teixeira & Hellewell, 1997a). The inhibitory effect of salmeterol was maintained even after eosinophils were washed prior to their infusion *in vivo*. We suggest, therefore, that the eosinophil is the main cellular target for the inhibitory effects of PDE4 inhibitors on ^{111}In -eosinophil trafficking in our model.

Several studies have recently shown that the release of endogenous corticosteroids by PDE4 inhibitors may account for some of their anti-inflammatory effect *in vivo* (reviewed in Teixeira *et al.*, 1997). Although this issue was not addressed in the present study, we believe that the release of endogenous steroids is unlikely to explain the ability of PDE4 inhibitors to suppress ^{111}In -eosinophil trafficking in guinea-pig skin. This is because (i) contrary to the immediate inhibitory effects of PDE4 inhibitors on ^{111}In -eosinophil trafficking, dexamethasone requires a 2.5 h pretreatment for inhibition to be observed (Teixeira *et al.*, 1996) and (ii) dexamethasone, but not PDE4 inhibitors, significantly inhibited oedema formation in guinea-pig skin (Teixeira *et al.*, 1996) suggesting a different mechanism of action.

Although PDE4 inhibitors are effective blockers of the PDE4 enzyme from neutrophils (see Table 1) and neutrophil function *in vitro* (e.g. Au *et al.*, 1998), we failed to observe any inhibitory effect on ^{111}In -neutrophil recruitment *in vivo* (see

Table 3). Similarly, PDE4 inhibitors have been shown to be inactive against neutrophil recruitment in some, but not all, animal models (reviewed in Teixeira *et al.*, 1997). As mentioned above, an effect on the expression of cell adhesion molecules is unlikely to explain this lack of effect. One possible alternative is that the cyclic AMP turnover in guinea-pig neutrophils is lower than that of guinea-pig eosinophils and it would be necessary to stimulate adenylate cyclase to observe an inhibitory effect. However, we failed to block ^{111}In -neutrophil recruitment with intradermal injection of E-type prostaglandins, agents which also elevate cyclic AMP in leukocytes (Teixeira *et al.*, 1993a). Clearly further studies are needed to explain the inability of PDE4 inhibitors to block ^{111}In -neutrophil recruitment in guinea-pig skin.

Inhibitors of PDE4 are effective blockers of the recruitment of ^{111}In -eosinophils into sites of allergic and mediator-induced inflammation in guinea-pig skin. We suggest that the main cellular target for the inhibitory effects of these agents is the eosinophils themselves. Contrary to *in vitro* studies of eosinophil function there was no correlation between inhibition of ^{111}In -eosinophil recruitment and inhibition of the enzyme catalytic site or the rolipram-binding site. We suggest that this guinea-pig model of eosinophil trafficking will be useful in the screening and development of PDE4 inhibitors for the oral treatment of diseases where eosinophils are thought to play an important pathophysiological role.

The National Asthma Campaign, Novartis (Switzerland) and Chiroscience supported this work. We thank Joanna Gregory, Chris Palmer, Trevor Morgan and Lewis Gowers for their invaluable contributions.

References

- AU, B.-T., TEIXEIRA, M.M., COLLINS, P.D. & WILLIAMS, T.J. (1998). Effect of PDE4 inhibitors on zymosan-induced IL-8 release from human neutrophils: Synergism with prostanoids and salbutamol. *Br. J. Pharmacol.*, **123**, 1260–1266.
- BARNETTE, M.S., GROUS, M., CIESLINSKI, L.B., BURMAN, M., CHRISTENSEN, S.B. & TORPHY, T.J. (1995a). Inhibitors of phosphodiesterase IV (PDE IV) increase acid secretion in rabbit isolated gastric glands: correlation between function and interaction with a high-affinity rolipram binding site. *J. Pharmacol. Exp. Ther.*, **273**, 1396–1402.
- BARNETTE, M.S., MANNING, C.D., CIESLINSKI, L.B., CHRISTENSEN, S.B. & TORPHY, T.J. (1995b). The ability of phosphodiesterase IV inhibitors to suppress superoxide production in guinea pig eosinophils is correlated with inhibition of phosphodiesterase IV catalytic activity. *J. Pharmacol. Exp. Ther.*, **273**, 674–679.
- BARNETTE, M.S., BARTUS, J.O.L., BURMAN, M., CHRISTENSEN, S.B., CIESLINSKI, L.B., ESSER, K.M., PRABHAKAR, U.S., RUSH, J.A. & TORPHY, T.J. (1996). Association of the anti-inflammatory activity of phosphodiesterase 4 (PDE4) inhibitors with either inhibition of PDE4 catalytic activity or competition for [^3H]rolipram binding. *Biochem. Pharmacol.*, **51**, 949–956.
- BARNETTE, M.S., CHRISTENSEN, S.B., ESSAYAN, E.M., GROUS, M., PRABHAKAR, U., RUSH, J.A., KAGEY-SOBOTKA, A. & TORPHY, T.J. (1998). SB 207499 (Ariflo), a potent and selective second-generation phosphodiesterase 4 inhibitor: *in vitro* anti-inflammatory actions. *J. Pharmacol. Exp. Ther.*, **284**, 420–426.
- BEAVO, J.A., CONTI, M. & HEASLIP, R.J. (1994). Multiple cyclic nucleotide phosphodiesterases. *Mol. Pharmacol.*, **46**, 399–405.
- BELETA, J., BOU, J., MIRALPEIX, M., DOMENECH, T., BERGA, P., GRISTWOOD, R.W. & PALACIOS, J.M. (1996). LAS 31025, a new compound with selective phosphodiesterase IV inhibitory activity. Third International Conference on Cyclic Nucleotide Phosphodiesterases: From Genes to Therapies, Glasgow.
- BLEASE, K., BURKE-GAFFNEY, A. & HELLEWELL, P.G. (1998). Modulation of cell adhesion molecule expression and function on lung microvascular endothelial cells by inhibition of phosphodiesterases 3 and 4. *Br. J. Pharmacol.*, **123**, 229–237.
- BRUIJNZEEL-KOOMEN, C., STORZ, E., MENZ, G. & BRUIJNZEEL, P. (1992). Skin eosinophilia in patients with allergic and nonallergic asthma and atopic dermatitis. *J. Allergy Clin. Immunol.*, **89**, 52–59.
- DENT, G., GIEMBYCZ, M.A., RABE, K.F. & BARNES, P.J. (1991). Inhibition of eosinophil cyclic nucleotide PDE activity and opsonised zymosan-stimulated respiratory burst by 'type IV'-selective PDE inhibitors. *Br. J. Pharmacol.*, **103**, 1339–1346.
- DUPLANTIER, A.J., BIGGERS, M.S., CHAMBERS, R.J., CHENG, J.B., COOPER, K., DAMON, D.B., EGGLE, J.F., KRAUS, K.G., MARFAT, A., MASAMUNE, H., PILLAR, J.S., SHIRLEY, J.T., UMLAND, J.P. & WATSON, J.W. (1996). Biarylcarboxylic acids and -amides: inhibition of phosphodiesterase type IV versus [^3H]rolipram binding activity and their relationship to emetic behaviour in the ferret. *J. Med. Chem.*, **39**, 120–125.
- FACCIOLI, L.H., NOURSHARGH, S., MOQBEL, R., WILLIAMS, F.M., SEHMI, R., KAY, A.B. & WILLIAMS, T.J. (1991). The accumulation of ^{111}In -eosinophils induced by inflammatory mediators *in vivo*. *Immunology*, **73**, 222–227.
- FOSTER, C.S., RICE, B.A. & DUTT, J.E. (1991). Immunopathology of atopic keratoconjunctivitis. *Ophthalmology*, **98**, 1190–1196.
- GARTNER, I. (1980). Separation of human eosinophils in density gradients of polyvinylpyrrolidone-coated silica gels (Percoll). *Immunology*, **40**, 133–136.
- GIEMBYCZ, M.A. & DENT, G. (1992). Prospects for selective cyclic nucleotide phosphodiesterase inhibitors in the treatment of bronchial asthma. *Clin. Exp. Allergy*, **22**, 337–344.

- JACOBITZ, S., MCLAUGHLIN, M.M., LIVI, G.P., BURMAN & TORPHY, T.J. (1996). Mapping the functional domains of human recombinant phosphodiesterase 4A: structural requirements for catalytic activity and rolipram binding. *Mol. Pharmacol.*, **50**, 891–899.
- KELLY, J.J., BARNES, P.J. & GIEMBYCZ, M.A. (1996). Phosphodiesterase 4 in macrophages: relationship between cAMP accumulation, suppression of cAMP hydrolysis and inhibition of [³H]R-(–)-rolipram binding by selective inhibitors. *Biochem. J.*, **318**, 425–436.
- KLEMENTSSON, H. (1992). Eosinophils and the pathophysiology of allergic rhinitis. *Clin. Exp. Allergy*, **22**, 1058–1064.
- MARTIN, L.B., KITA, H., LEIFERMAN, K.M. & GLEICH, G.J. (1996). Eosinophils in Allergy: Role in Disease, Degranulation and Cytokines. *Int. Arch. Allergy Immunol.*, **109**, 207–215.
- MONTEFORT, S., HERBERT, C.A., ROBINSON, C. & HOLTGATE, S.T. (1992). The bronchial epithelium as a target for inflammatory attack in asthma. *Clin. Exp. Allergy*, **22**, 511–520.
- PERRY, M.J., O'CONNELL, J., WALKER, C., CRABBE, T., BALDOCK, D., RUSSELL, A., LUMB, S., HUANG, Z., HOWAT, D., ALLEN, R., MERRIMAN, M., WALLS, J., DANIEL, T., HUGHES, B., LALIBERTE, F., HIGGS, G.A. & OWENS, R.J. (1998). CDP840. A novel inhibitor of PDE-4. *Cell Biochem. Biophys.*, **29**, 113–132.
- RAEBURN, D., UNDERWOOD, S.L., LEWIS, S.A., WOODMAN, V.R., BATTRAM, C.H., TOMKINSON, A., SHARMA, S., JORDA, R., SOUNESS, J.E., WEBBER, S.E. & KARLSSON, J.-A. (1994). Anti-inflammatory and bronchodilator properties of RP 73401, a novel and selective phosphodiesterase type IV inhibitors. *Br. J. Pharmacol.*, **113**, 1423–1431.
- SCHNEIDER, H.H., SCHMIECHEN, R., BREZINSKI, M. & SEIDLER, J. (1986). Stereospecific binding of the antidepressant rolipram to brain protein structures. *Eur. J. Pharmacol.*, **127**, 105–115.
- SOUNESS, J.E., CARTER, C.M., DIOCEE, B.K., HASSALL, G.A., WOOD, L.J. & TURNER, N.C. (1991). Characterization of guinea-pig eosinophil phosphodiesterase activity. *Biochem. Pharmacol.*, **42**, 937–945.
- TEIXEIRA, M.M., GRISTWOOD, R.W., COOPER, N. & HELLEWELL, P.G. (1997). Phosphodiesterase (PDE)4 inhibitors: anti-inflammatory drugs of the future? *Trends Pharmacol. Sci.*, **18**, 164–171.
- TEIXEIRA, M.M. & HELLEWELL, P.G. (1994). Effect of a 5-lipoxygenase inhibitor, ZM 230487, on cutaneous allergic inflammation in the guinea pig. *Br. J. Pharmacol.*, **111**, 811–818.
- TEIXEIRA, M.M. & HELLEWELL, P.G. (1997a). Evidence that the eosinophil is a cellular target for the inhibitory action of salmeterol on eosinophil recruitment in vivo. *Eur. J. Pharmacol.*, **323**, 255–260.
- TEIXEIRA, M.M. & HELLEWELL, P.G. (1997b). The selectin binding polysaccharide fucoidin inhibits eosinophil recruitment in vivo. *Br. J. Pharmacol.*, **120**, 1059–1066.
- TEIXEIRA, M.M., REYNIA, S., ROBINSON, M., SHOCK, A., WILLIAMS, T.J., WILLIAMS, F.M., ROSSI, A.G. & HELLEWELL, P.G. (1994a). Role of CD18 in the accumulation of eosinophils and neutrophils and local oedema formation in inflammatory reactions in guinea pig skin. *Br. J. Pharmacol.*, **111**, 1205–1211.
- TEIXEIRA, M.M., WILLIAMS, T.J. & HELLEWELL, P.G. (1993a). E-type prostaglandins enhance local oedema formation and neutrophil accumulation but suppress eosinophil accumulation in guinea pig skin. *Br. J. Pharmacol.*, **110**, 416–422.
- TEIXEIRA, M.M., WILLIAMS, T.J., & HELLEWELL, P.G. (1993b). Role of prostaglandins and nitric oxide in acute inflammatory reactions in guinea pig skin. *Br. J. Pharmacol.*, **110**, 1515–1521.
- TEIXEIRA, M.M., WILLIAMS, T.J. & HELLEWELL, P.G. (1994b). Effect of phosphodiesterase isoenzyme inhibitors on cutaneous inflammation in the guinea pig. *Br. J. Pharmacol.*, **112**, 332–340.
- TEIXEIRA, M.M., WILLIAMS, T.J. & HELLEWELL, P.G. (1995). Mechanisms and pharmacological modulation of eosinophil accumulation in vivo. *Trends Pharmacol. Sci.*, **16**, 418–423.
- TEIXEIRA, M.M., WILLIAMS, T.J. & HELLEWELL, P.G. (1996). Effects of dexamethasone and cyclosporin A on the accumulation of eosinophils in acute inflammation in the guinea pig. *Br. J. Pharmacol.*, **118**, 317–324.
- THOMPSON, W.J., TERASAKI, W.L., EPSTEIN, P.M. & STRADA, S.J. (1979). Assay of cyclic nucleotide phosphodiesterase and resolution of multiple forms of the enzyme. *Adv. Cyclic Nucleotide Res.*, **10**, 69–92.
- TORPHY, T.J. (1998). Phosphodiesterase isoenzymes. Molecular targets for novel antiasthma drugs. *Am. J. Resp. Crit. Care Med.*, **157**, 351–370.
- VENGE, P. (1990). The human eosinophil in inflammation. *Agents Actions*, **29**, 122–126.
- WARDLAW, A.J., DUNNETTE, S., GLEICH, G.J., COLLINS, J.V. & KAY, A.B. (1988). Eosinophils and mast cells in bronchoalveolar lavage in subjects with mild asthma. Relationship to bronchial hyperreactivity. *Am. Rev. Respir. Dis.*, **137**, 62–69.
- WEG, V.B., WATSON, M.L., CORDEIRO, R.S.B. & WILLIAMS, T.J. (1991). Histamine, leukotriene D4 and platelet activating factor in guinea pig passive cutaneous anaphylaxis. *Eur. J. Pharmacol.*, **204**, 157–163.
- WEG, V.B., WILLIAMS, T.J., LOBB, R.R. & NOURSHARGH, S. (1993). A monoclonal antibody recognising very late activation antigen-4 (VLA-4) inhibits eosinophil accumulation in vivo. *J. Exp. Med.*, **177**, 561–566.

(Received December 10, 1998

Revised February 5, 1999

Accepted February 9, 1999)

PDE4 INHIBITORS: NEW XANTHINE ANALOGUES

John G Montana*, Nicola Cooper, Hazel J Dyke, Lewis Gowers, Joanna P Gregory, Paul G Hellewell^a, Jadwiga Miotla^a, Ken Morris^c, Robert Naylor^b, Bishwa Tuladhar^b and Julie B H Warneck

Chiroscience Ltd, Cambridge Science Park, Milton Road, Cambridge CB4 4WE, UK

^a*Department of Pharmacology, National Heart and Lung Institute, Dovehouse Street, London, SW3 6LY, UK*

^b*Pharmacology Department, University of Bradford, Bradford, BD7 1DP*

^c*Maybridge Chemical Company Ltd, Trevillet, Tintagel, Cornwall PL34 OHW*

Received 15 June 1998; accepted 10 September 1998

Abstract: Novel xanthine analogues are described which are selective PDE4 inhibitors with improved therapeutic potential over theophylline. © 1998 Elsevier Science Ltd. All rights reserved.

Introduction

Asthma is a chronic, severe, debilitating and often fatal disease whose incidence is increasing, primarily in the Western World. In the UK alone, it is responsible for 2000 deaths per annum among adults and children. Current therapies are based upon inhaled β -agonists¹, which offer only symptomatic relief, and steroids which have associated side effects. There is obviously a requirement for an improved oral anti-inflammatory agent to treat the underlying disease.

Cyclic adenosine monophosphate (cAMP) is converted by some phosphodiesterase enzymes (PDEs) into the inactive acyclic 5'-adenosine monophosphate (5'-AMP). Inhibition of PDE activity thus causes the cellular levels of cAMP to be potentiated, thereby activating the protein kinases responsible for decreasing inflammatory cell activity and airway smooth muscle tone.² Seven families of PDEs have been identified to date³; PDE4 is cAMP specific and is found in airway smooth muscle, all inflammatory cells and the vascular endothelium and selective inhibitors of PDE4 have shown anti-inflammatory activity in animal models.⁴ The anti-inflammatory action stems from the inhibition of cell function and cytokine liberation (e.g. TNF α , IL-2, IL-5, IFN), leading to the inhibition of cell adhesion and proliferation.¹

Theophylline (1), a dimethylxanthine, has been used to treat asthma for over 60 years. However, its clinical use is limited by adverse reactions on the cardiovascular and central nervous systems as well as its narrow therapeutic index and high inter-individual

*E-mail johnmontana@chiroscience.com Fax +44 1223 420440

variability in absorption, metabolism and clearance⁵. At least some of the beneficial actions of theophylline are associated with its ability to inhibit PDE4⁴, but theophylline is both weak and non-selective. Several publications have appeared describing the SAR of theophylline analogues⁶. A more potent and PDE4 selective xanthine should provide an improved agent for the treatment of asthma.

Recent evidence suggests that the PDE4 enzyme possesses two binding sites, a catalytic site and a high affinity site whose nature is not completely understood.⁷ However there is increasing support for the hypothesis that binding to this high affinity site (rolipram binding activity, RBA) correlates with the observed side-effects.⁸ Thus minimisation of affinity for the high affinity site should provide a compound with an improved therapeutic ratio. Based on this approach, our objective was to identify an orally active PDE4 inhibitor which does not cause nausea/emesis in man whilst maintaining the full spectrum of beneficial biological actions. Theophylline has only weak affinity for the high affinity binding site and the side effects observed with this compound are thought to be associated with activity against other PDE enzymes and adenosine receptors.

Results

A series of novel xanthines has been prepared and the activities of these compounds are provided in Tables 1, 2 and 3.

Compound	R	PDE4 IC ₅₀ μM	RBA IC ₅₀ μM	Ratio PDE4/RBA
theophylline		39% @ 200	27% @ 100	
1a	Cl	6.55	0.042	156
1b	CO ₂ H	110	ND	
1c	CO ₂ Me	4.08	0.009	453
1d	SOMe	56	1.6	35
1e	NH ₂	11	0.32	34
1f	OMe	6.01	0.017	353

Table 1. *In vitro* activity and selectivity of xanthines.
All results are an average of at least 2 determinations, each run in triplicate. ND = not determined

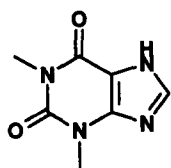

theophylline (1)

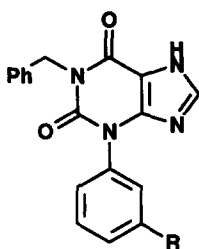

(2)

It is evident from the results presented in Table 1 that the nature of R has a dramatic effect on PDE4 activity. Polar groups such as CO₂H and S_{OMe} are not tolerated, halogens and OMe provide compounds with reasonable potency but poor ratio and NH₂ provides a compound with reduced potency. Compound 1f was found to be selective for PDE4 over PDE3 (24% inhibition at 20 μM for PDE3). The effect of ortho- substitution was also investigated, and the results for selected compounds are shown in Table 2.

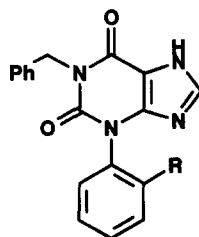

(2)

Compound	R	PDE4 IC ₅₀ μM	RBA IC ₅₀ μM	Ratio PDE4/RBA
2a	Me	7.97	0.67	11.9
2b	F	2.4	0.22	10.9
2c	CF ₃	20	ND	
2d	SMe	20	ND	
2e	SOMe	100	ND	
2f	^t Bu	>20	ND	
2g	H	4.8	0.08	60

Table 2. *In vitro* activity and selectivity of o-substituted xanthines.

All results are an average of at least 2 determinations, each run in triplicate.

Only small lipophilic ortho- substituents are tolerated as can be seen from Table 2. Superior ratios for PDE4 versus high affinity binding were achieved in this series, with

compound (2a) possessing the best ratio seen so far in this type of compound. The ratio PDE4/RBA for compound (2a) is 100 better than the ratio for early compounds such as (1c). Replacement of the aryl portion of the benzyl substituent by heteraromatic groups was also undertaken and results are presented in Table 3.

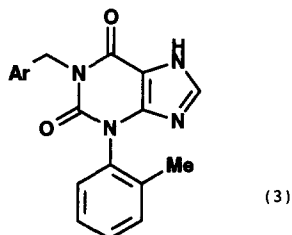

Compound	Ar	PDE4 IC ₅₀ μM	RBA IC ₅₀ μM	Ratio PDE4/RBA
3a	Ph	7.97	0.67	11.9
3b	2-furyl	11.95	1.1	10.9
3c	2-thienyl	4.2	1.02	4.1

Table 3. *In vitro* activity and selectivity of xanthines
All results are an average of at least 2 determinations, each run in triplicate.

The thienylmethyl residue provides a useful alternative to benzyl, whereas replacement of benzyl by furfuryl results in a loss of potency. Compound (3c) also demonstrates a good ratio.

Chemistry

The xanthines were prepared using the standard route⁹ depicted in Scheme 1. An appropriate aniline (i) was condensed with a suitable isocyanate (ii) to provide a urea (iii) which was acylated with cyanoacetic acid to provide the acylurea (iv). Hydrolysis of the cyano group and *in situ* cyclisation provided the aminouracil^{9a, 9b} (v). Nitrosation, reduction of the resultant nitroso intermediate to the corresponding amine and reaction of the resultant diamine with formic acid were all carried out in one pot to provide the desired xanthines^{9c} (vi).

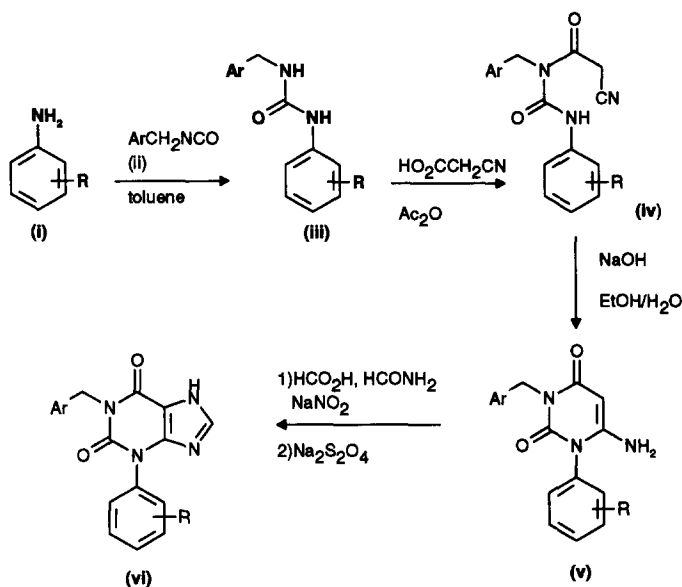

Scheme 1. Synthesis of xanthines

***In vivo* Results**

Compound (3c) was selected for *in vivo* evaluation, based on its activity against PDE4 and improved ratio for PDE4 versus high affinity binding. The compound was evaluated in a guinea-pig skin model of eosinophilia¹⁰, a guinea-pig lung model of eosinophilia¹¹ and a ferret model of emesis¹². In the skin model, compound (3c) dosed orally demonstrated an excellent inhibition of eosinophilia produced by a range of mediators¹³ as shown in Chart 1. In the lung model, compound (3c) demonstrated 56% and 70% inhibition of eosinophilia at oral doses of 10 and 30mg/kg respectively (rolipram 48% at 10mg/kg). No emesis or CNS related side effects were observed when compound (3c) was dosed orally to ferrets at 10mg/kg.

Conclusions

A novel series of xanthines with acceptable PDE4 activity and improved selectivity versus the high affinity site has been identified. A selected compound from this series, compound (3c) has demonstrated excellent *in vivo* activity and a good therapeutic index as determined by efficacious dose versus emetic dose.

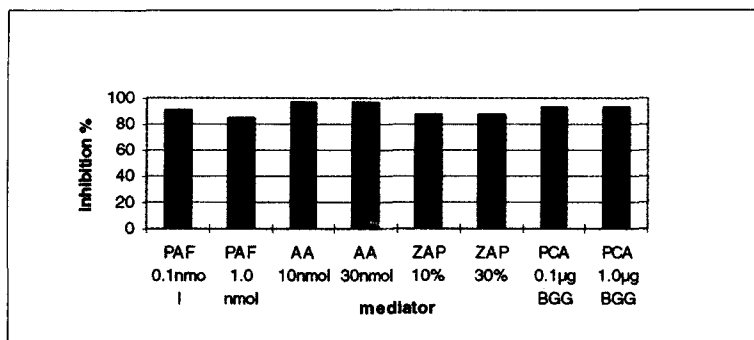

Chart 1. Inhibition of skin eosinophilia by compound (3c) @5mg/kg po

References

- Giembycz, M. A. *Trends Pharmacol. Sci.* **1996**, *17*, 331-336.
- Nicholson, C.D.; Shahid, M. *Pulmon. Pharmacol.* **1994**, *7*, 1; Palacios, J.M.; Beleta, J.; Segarra, V. *Il Farmaco* **1995**, *50*, 819.
- Demoliou-Mason, C.D. *Exp. Opin. Ther. Patents* **1995**, *5*, 417.
- Teixeira, M.M.; Gristwood, R.W.; Cooper, N.; Hellewell, P.G. *TIPS* **1997**, *18*, 164; Banner, K.H.; Page, C.P. *Clin. Exp. Allergy* **1996**, *26*(Supplement 2), 2.
- Perasson, C.G.A.; Andersson, K.E.; Kjellin, G. *Life Sci.* **1986**, *38*, 1057
- Sakai, R.; Konno, K.; Yamamoto, Y.; Sanae, F.; Takagi, K.; Hasegawa, T.; Iwasaki, N.; Kakiuchi, M.; Kato, H.; Miyamoto, K. *J. Med. Chem.* **1992**, *35*, 4039; Miyamoto, K.; Yamamoto, Y.; Kurita, M.; Sakai, R.; Konno, K.; Sanae, F.; Ohshima, T.; Takagi, K.; Hasegawa, T.; Iwasaki, N.; Kakiuchi, M.; Kato, H. *J. Med. Chem.* **1993**, *36*, 1380; Buckle, R.; Arch, J.; Connolly, B.; Foster, K.; Murray, K.; Readshaw, S.; Smallridge, M.; Smith, D. *J. Med. Chem.* **1994**, *37*, 476.
- Muller, T.; Engels, P.; Fozard, J.R. *Trends Pharmacol. Sci.* **1996**, *17*, 294; Kelly, J.J.; Barnes, P.J.; Giembycz, M.A. *Biochem.* **1996**, *318*, 425; Jacobitz, S.; McLaughlin, M.M.; Livi, G.P.; Burman, M.; Torphy, T.J. *Mol. Pharmacol.* **1996**, *50*, 891.
- Duplantier, A.J.; Biggers, M.S.; Chambers, R.J.; Cheng, J.B.; Cooper, K.; Damon, D.B.; Eggler, J.F.; Kraus, K.G.; Marfat, A.; Masamune, H.; Pillar, J.S.; Shirley, J.T.; Umland, J.P.; Watson, J.W. *J. Med. Chem.* **1996**, *39*, 120.
- Papesch, V. and Schroder, E.F. *J. Org. Chem.* **1951**, *16*, 1879.
- Ohtsuka, Y. *Bull. Chem. Soc. Jap.* **1973**, *46*, 506.
- Bredereck, H. and Edenhofer, A. *Chem. Berichte* **1955**, 1306.
- Teixeira, M.M.; Reynia, S.; Robinson, M.; Shock, A.; Williams, T.J.; Williams, F.M.; Rossi, A.G.; Hellewell, P.G. *Br. J. Pharmacol.* **1994**, *111*, 811; Teixeira, M.M.; Williams, T.J.; Hellewell, P.G.; *Br. J. Pharmacol.* **1993**, *110*, 416.
- Kallos, P. and Kallos, L. *Int. Arch. Appl. Immunol.* **1984**, *73*, 77; Sanjar, S. Aoki, S. Kristersson, A. Smith, D. and Morley, J.; *Br J Pharmacol.* **1990**, *99*, 679.
- Costall, B.; Domeneq, A. M.; Naylor, R. J; Tattersall, F. D. *Neuropharmacology* **1987**, *26*, 1321-1326.
- The mediators used as inflammagens in the guinea pig skin eosinophilia model were platelet aggregating factor (PAF), Arachidonic acid (AA) and zymosan-activated plasma (ZAP). Additionally sensitisation to bovine gamma globulin followed by an id challenge of antisera results in a passive cutaneous anaphylactic (PCA) response.

ARYL SULFONAMIDES AS SELECTIVE PDE4 INHIBITORS

John G Montana^{*}, George M Buckley, Nicola Cooper, Hazel J Dyke, Lewis Gowers, Joanna P Gregory, Paul G Hellewell^a, Hannah J Kendall, Christopher Lowe, Robert Maxey, Jadwiga Miotla^a, Robert J Naylor^b, Karen A Runcie, Bishwa Tuladhar^b and Julie B H Warneck

Chiroscience Ltd, Cambridge Science Park, Milton Road, Cambridge CB4 4WE, UK

^a*Department of Pharmacology, National Heart and Lung Institute, Dovehouse Street, London, SW3 6LY, UK*

^b*Pharmacology Department, University of Bradford, Bradford, BD7 1DP*

Received 30 March 1998; accepted 2 September 1998

Abstract: A series of novel selective phosphodiesterase 4 (PDE4) inhibitors has been developed which displays activity both *in vitro* and *in vivo*. These compounds possess good selectivity for the catalytic site of PDE4 over the high affinity Rolipram binding site. *In vivo* studies demonstrate a reduced propensity to display the emetic side effects which are commonly observed with PDE4 inhibitors. © 1998 Elsevier Science Ltd. All rights reserved.

Introduction

Asthma is a chronic, debilitating and often fatal disease whose incidence is increasing, primarily in the Western World. Current therapies are based upon inhaled β -agonists¹ to treat bronchoconstriction and steroids to treat the underlying inflammation, the latter of which has associated side effects. There is thus a requirement for an oral anti-inflammatory agent to treat the underlying disease; in recent years, the interest in this field has grown at a rapid pace, leading to the development of many orally active compounds that are able to selectively inhibit the PDE4 enzyme.²

Cyclic adenosine monophosphate (cAMP) is converted by phosphodiesterase enzymes (PDEs) into the inactive acyclic 5'-adenosine monophosphate (5'-AMP). Inhibition of PDE activity thus causes the cellular levels of cAMP to be potentiated, thereby activating the protein kinases responsible for decreasing inflammatory cell activity and airway smooth muscle tone.³ Seven families of PDEs have been identified to date;⁴ PDE4 is cAMP specific and is found in airway smooth muscle, all inflammatory cells and the vascular endothelium. Selective inhibitors of PDE4 have shown anti-inflammatory activity in animal models.⁵ The anti-inflammatory action stems from the inhibition of cell function and cytokine liberation (e.g. TNF α , IL-2, IL-5, IFN), leading to the inhibition of cell adhesion and proliferation.

The archetypal PDE4 inhibitor, Rolipram (1),⁶ although possessing potent PDE4 inhibitory activity, causes emesis in ferrets even at doses as low as 0.1 mg/kg p.o.. The reason for this side-effect is not clear, but evidence suggests that Rolipram binds to the PDE4 enzyme at both the catalytic site and a high affinity binding site whose nature is not completely understood.⁷ However there is increasing support for the hypothesis that binding to this high affinity site (Rolipram binding activity, RBA) correlates with the observed side-effects.⁸

Results

Our objective was to identify an orally active PDE4 inhibitor which does not cause nausea/emesis in man whilst maintaining the full spectrum of beneficial biological actions. Based on available literature SAR, database mining was used to select structurally diverse molecules. These compounds were screened in

e-mail: johnmontana@chiroscience.com
FAX: 01223 428678

primary *in vitro* assays; the initial 'hits' are exemplified below (2,3) and were found to be selective for PDE4 over other PDE isoforms (Table 1).

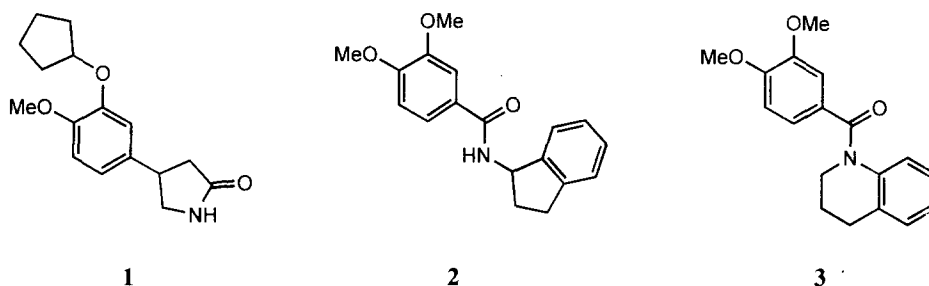

Compound	PDE1	PDE2	PDE3	PDE4 ^a	PDE5	RBA ^b	Ratio PDE4/RBA
1 Rolipram	>200 μ M	28% (200 μ M)	27% (200 μ M)	3.5	200	0.02	175
2	14%	37%	53%	11	24%	3	3.7
3	14%	21%	31%	20	12%	15% (10 μ M)	<1

Values shown are IC₅₀s (μ M) or percent inhibitions at 20 μ M unless otherwise stated.

Table 1. PDE selectivity profile of initial amide hits.

Although the absolute potency of compounds 2 and 3 against the PDE4 isozyme was only modest, the ratio of PDE4 catalytic activity to high-affinity Rolipram binding activity (RBA) was far superior to that observed for Rolipram, suggesting that these compounds would possess a therapeutic advantage.

Replacement of the amide moiety with a sulfonamide led to a novel series of compounds possessing improved PDE4 inhibitory activity and a very favorable ratio of PDE4: RBA (Table 2). In this series of compounds, excellent selectivity for the PDE4 enzyme over the PDE3 isoenzyme was also maintained (data not shown). This is important since inhibition of PDE3 may result in cardiotoxicity.⁴

Our initial observation was that replacement of the cyclopentyl moiety with a methyl group in R¹ led to a greatly improved ratio of catalytic to Rolipram binding activity. Examination of these results for compounds 4 - 15 suggests that for optimum potency, R² should be CH₂aryl or CH₂heteroaryl together with an alkyl or substituted alkyl substituent with an optimum chain length of 3 or 4 carbon atoms for R³. Additionally when R³ represents a sulfone as in compounds 16 - 19, equally good absolute potency and therapeutic ratio are observed.

Compounds 20, 22, 24 - 27 in which the R² group has been modified to a substituted indanyl moiety leading to a more conformationally constrained system also demonstrated good potency and selectivity for the catalytic binding site over the Rolipram binding site. Evidence suggests that the aromatic ring present in R² is essential for good *in vitro* potency against the PDE4 enzyme, but that a substituted alkyl side chain on the sulfonamide is not an absolute requirement.

An extension of this work led to a series of compounds possessing an endocyclic sulfonamide nitrogen atom, invoking further conformational restriction. Many of these compounds were found to possess both submicromolar activity against PDE4 and an excellent PDE4:RBA ratio and are exemplified by compounds 29-33 in Table 3.

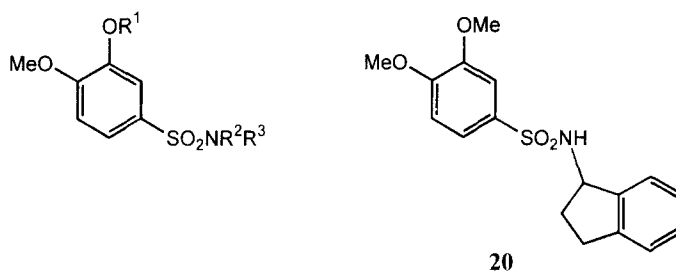

Compound	R¹	R²	R³	PDE4 IC ₅₀	RBA IC ₅₀	Ratio PDE4/RBA
1 Rolipram				3.5	0.02	175
4	Me	furan-2-ylmethyl	CH ₂ CH ₂ CN	10	37% (10μM)	<1
5	Cp	furan-2-ylmethyl	CH ₂ CH ₂ CN	32% (20μM)	10	>1
6	Me	furan-2-ylmethyl	CH ₂ CH ₂ CH ₂ CN	9	37% (10μM)	<1
7	Me	furan-2-ylmethyl	CH ₂ CN	30% (20μM)	36% (10μM)	>1
8	Me	furan-2-ylmethyl	CH ₂ COCH ₃	24	35	0.69
9	Me	furan-2-ylmethyl	CH ₂ CH ₂ CH ₃	1.5	15	0.10
10	Me	furan-2-ylmethyl	CH ₂ CO ₂ Me	10	23% (100μM)	<1
11	Me	4-(methylamino-carbonyl)phenylmethyl	CH ₂ CH ₂ CH ₃	1.9	4.3	0.44
12	Me	tetrahydrofuran-2-ylmethyl	CH ₂ CH ₂ CN	19	112	0.17
13	Me	H	CH ₂ CH ₂ CN	17.6	50	0.35
14	Me	pyrid-3-ylmethyl	CH ₂ Ph	5	8% (10μM)	<1
15	Me	pyrid-3-ylmethyl	H	39% (200μM)	41% (100mM)	>1
16	Me	pyrid-3-ylmethyl	SO ₂ Me	6	50	0.12
17	Cp	pyrid-3-ylmethyl	SO ₂ Me	2	4.5	0.44
18	(CH ₂) ₃ Ph	pyrid-3-ylmethyl	SO ₂ Me	1.5	18% (1μM)	<1
19	Me	pyrid-3-ylmethyl	SO ₂ (CH ₂) ₂ NHSO ₂ Ph	3	24	0.13
20	Me	indan-1-yl	H	6	12% (10μM)	<0.6
21	Me	cyclopentyl	H	100	19% (100μM)	<1
22	Me	indan-1-yl	CH ₂ CH ₂ CN	4.1	26% (10μM)	<0.4
23	Me	1,2,3,4-tetrahydro-naphth-1-yl	CH ₂ CH ₂ CN	6.4	30% (10μM)	<0.6
24	Me	5-chloroindan-1-yl	H	5.2	12% (10μM)	<0.5
25	Me	6-methoxyindan-1-yl	H	2.5	2% (10μM)	<0.25
26	Me	indan-1-yl	pyrid-3-ylmethyl	9	20% (10μM)	<0.9
27	Me	indan-1-yl	pyrid-2-ylmethyl	5.3	12% (10μM)	<0.5
28	Me	benzyl	pyrid-2-ylmethyl	7.8	5% (10μM)	<0.7

Table 2. *In vitro* activity and selectivity of sulfonamides. All data are mean values and number of determinants is ≥2.

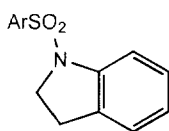

Ar = 3,4-dimethoxyphenyl

29

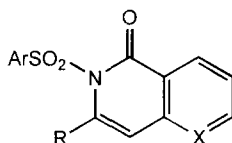

30 R = Ph; X = N

31 R = Ph; X = CH

32 R = H; X = CH

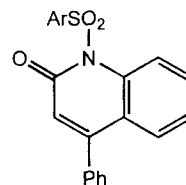

33

Compound	PDE4 IC ₅₀ (μM)	RBA IC ₅₀	Ratio PDE4/RBA
29	4.3	18% (10μM)	<0.43
30	1.5	20% (10μM)	<0.15
31	0.6	31% (10μM)	<0.06
32	0.5	4.0μM	0.12
33	0.5	14% (10μM)	<0.05

Table 3. Activity profile of sulfonamides prepared from cyclic amines.

All data are mean values and number of determinants is ≥ 2 .

The formation of a 'sulfonimide' (30-33) increased the absolute PDE4 inhibitory activity, while the construction of a highly conjugated system (30, 31, 33) afforded a highly favorable PDE4:RBA ratio.

Chemistry

The general synthetic route to these compounds is outlined in Scheme 1 below. Coupling of the appropriate amine with 3,4-dimethoxysulfonyl chloride affords the secondary sulfonamides which are subsequently treated with the appropriate alkylating or sulfonylating agent.

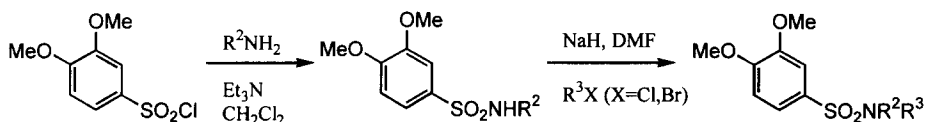

Scheme 1. Sulfonamide preparation.

In cases where R^1 is other than a methyl group, then the sequence shown in Scheme 2 is followed. Directed sulfonylation of the aromatic ring is achieved by using methanesulfonyl-protected 2-methoxyphenol. This is followed by sulfonamide formation, deprotection, *O*-alkylation and *N*-alkylation to form the desired sulfonamides. In cases where $R^2 = \text{CH}_2\text{CH}_2\text{CN}$, the protocol depicted in Scheme 3 is followed.

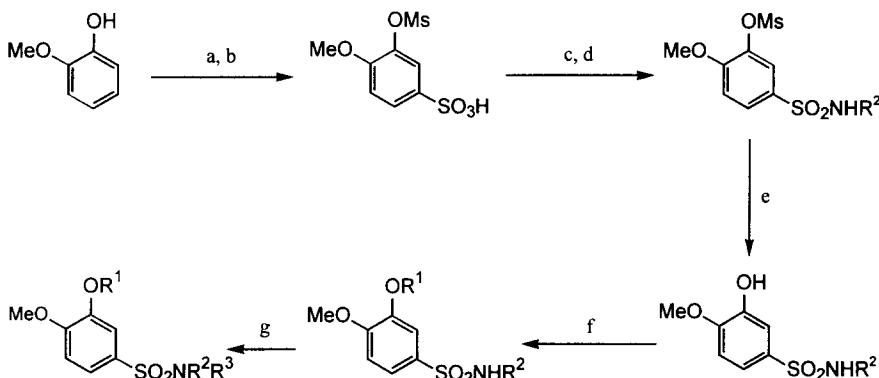

Scheme 2. a) MsCl, Et₃N, CH₂Cl₂; b) ClSO₃H; c) (COCl)₂, CH₂Cl₂; d) R²NH₂, Et₃N, CH₂Cl₂; e) NaOH, dioxane, 65°C; f) R¹Br, Cs₂CO₃, DMF; g) R³X (X = Cl, Br), NaH, DMF.

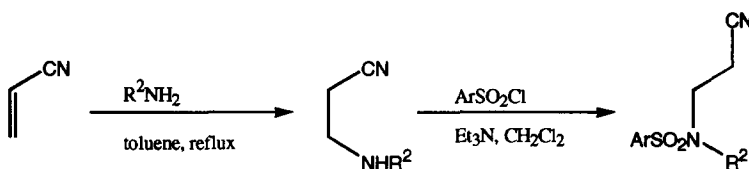

Scheme 3. Ar = 3,4-dimethoxyphenyl

Compound **29** was prepared simply by treating the appropriate amine with 3,4-dimethoxybenzenesulfonyl chloride in the presence of triethylamine. Compounds **30-33** were prepared by treating the appropriate amide with sodium hydride then 3,4-dimethoxybenzenesulfonyl chloride, as exemplified in Scheme 4.

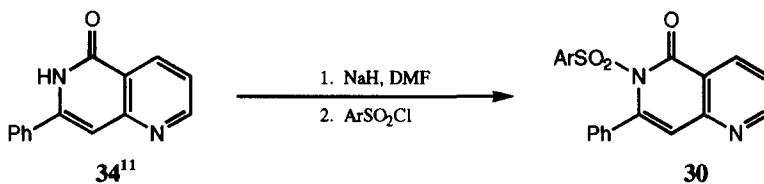

Scheme 4. Ar = 3,4-dimethoxyphenyl

In vivo assay

A guinea pig skin eosinophilia model was developed to assess the efficacy of these compounds *in vivo*.¹² Compound **20**, having a similar *in vitro* PDE4 activity to Rolipram but a better ratio, demonstrates an average 51% inhibition of eosinophilia at 5mg/kg ip, compared to Rolipram which gives 72% inhibition (Figure 1). However, in a model of ferret emesis,¹³ Rolipram produces CNS effects at 0.1mg/kg i.p. and retching and vomiting at 3.0mg/kg i.p. (Figure 2), whereas compound **20** displays none of these side effects up to the highest dose tested (10 mg/kg i.p.). This demonstrates that an improvement of the *in vitro* ratio of catalytic PDE4 activity to Rolipram binding activity can translate to an improved *in vitro* profile.

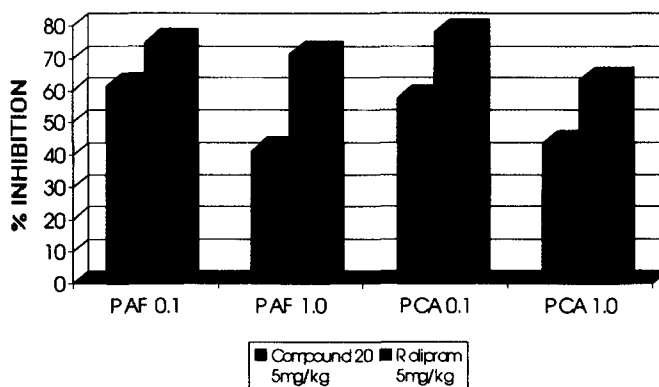

Figure 1. Inhibition of skin eosinophilia in the guinea pig by compound **20** and Rolipram.

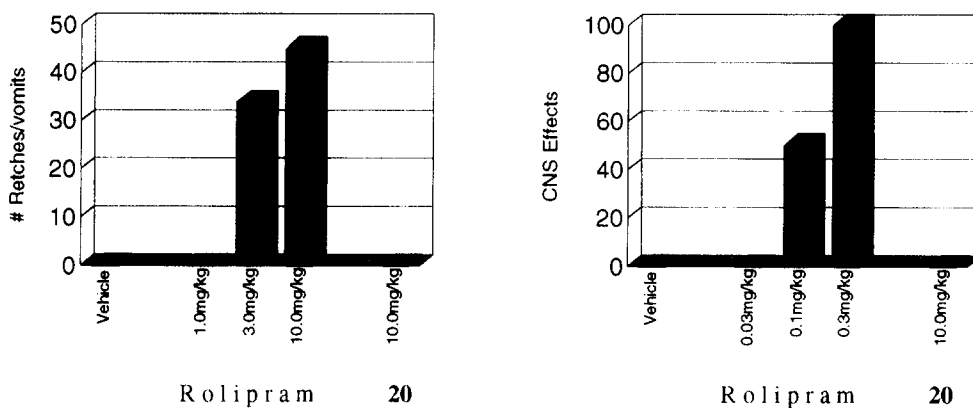

Figure 2. Retching and vomiting and CNS effects observed in ferrets by Rolipram and compound **20**. CNS effects are a compilation of mouth scratching, head burrows and salivation.

Conclusions

The initial hits demonstrated that adequate PDE4 potency could be achieved with a good catalytic site to high affinity site binding ratio. Subsequent generation of SAR led to several sulfonamide series that provided significant improvements in potency and/or selectivity. Additionally these compounds exhibit a good *in vivo* profile and strong support is lent to the hypothesis that Rolipram binding activity (RBA) is responsible for the observed emetic side effects so often associated with PDE4 inhibitors. The sulfonamide **20** exhibits no such side effects at efficacious doses. Work is ongoing to further improve these compounds which will be reported in due course.

References

- Giembycz, M. A. *Trends Pharmacol. Sci.* **1996**, *17*, 331-336.
- Stafford, J.A.; Feldman, P.L. *Ann. Rep. Med. Chem.*, **1996**, *31*, 71 and references therein; Hughes, B.; Owens, R.; Perry, M.; Warrelow, G.; Allen, R. *Drug Discovery Today*, **1997**, *2*, 89.
- Nicholson, C.D.; Shahid, M. *Pulmon. Pharmacol.* **1994**, *7*, 1; Palacios, J.M.; Beleta, J.; Segarra, V. *Il Farmaco* **1995**, *50*, 819; Torphy, T.J.; Murray, K.J.; Arch, J.R.S. in *Drugs and the Lung*; Page, C.P.; Metzger, W.J., Eds.; Raven Press: New York, 1994; pp 397-447.
- Demoliou-Mason, C.D. *Exp. Opin. Ther. Patents* **1995**, *5*, 417.
- Teixeira, M.M.; Gristwood, R.W.; Cooper, N.; Hellewell, P.G. *TIPS* **1997**, *18*, 164; Banner, K.H.; Page, C.P. *Clin. Exp. Allergy* **1996**, *26*(Supplement 2), 2.
- Schwabe, U.; Miyake, M.; Ohga, Y.; Daly, J. *J. Mol. Pharmacol.* **1976**, 900.
- Muller, T.; Engels, P.; Fozard, J.R. *Trends Pharmacol. Sci.* **1996**, *17*, 294; Kelly, J.J.; Barnes, P.J.; Giembycz, M.A. *Biochem.* **1996**, *318*, 425; Jacobitz, S.; McLaughlin, M.M.; Livi, G.P.; Burman, M.; Torphy, T.J. *Mol. Pharmacol.* **1996**, *50*, 891.
- Duplantier, A.J.; Biggers, M.S.; Chambers, R.J.; Cheng, J.B.; Cooper, K.; Damon, D.B.; Eggler, J.F.; Kraus, K.G.; Marfat, A.; Masamune, H.; Pillar, J.S.; Shirley, J.T.; Umland, J.P.; Watson, J.W. *J. Med. Chem.* **1996**, *39*, 120.
- Thompson, W.J.; Terasaki, W.L.; Epstein, P.M.; Strada, S. *J. Adv. Cyc. Nuc. Res.* **1979**, *10*, 69.
- Schneider, H.H.; Schmeichen, R.; Brezinski, M.; Seidler, J. *Eur. J. Pharmacol.* **1997**, *127*, 105.
- Ames, D.E.; Dodds, W.D. *J. Chem. Soc., Perkin Trans. 1*, **1972**, 705.
- Teixeira, M.M.; Reynia, S.; Robinson, M.; Shock, A.; Williams, T.J.; Williams, F.M.; Rossi, A.G.; Hellewell, P.G. *Br. J. Pharmacol.* **1994**, *111*, 811; Teixeira, M.M.; Williams, T.J.; Hellewell, P.G.; *Br. J. Pharmacol.* **1993**, *110*, 416.
- Costall, B.; Domeney, A.M.; Naylor, R.J.; Tattersall, F.D. *Neuropharmacology* **1987**, *26*, 1321.

**SYNTHESIS AND EVALUATION OF A NOVEL SERIES OF
PHOSPHODIESTERASE IV INHIBITORS.
A POTENTIAL TREATMENT FOR ASTHMA**

Steven C. Beasley,^a Nicola Cooper,^a Lewis Gowers,^a Joanna P. Gregory,^a Alan F Haughan,^a
Paul G. Hellewell,^c David Macari,^c Jadwiga Miotla,^c John G. Montana,^{a*} Trevor Morgan,^a
Robert Naylor,^b Karen A. Runcie,^a Bishwa Tuladhar,^b Julie B. H. Warneck^a

(a) Chiroscience Ltd, Cambridge Science Park, Milton Road, Cambridge CB4 4WE, UK

(b) Pharmacology Department, University of Bradford, Bradford, BD7 1DP

(c) Department of Pharmacology, National Heart and Lung Institute, Dovehouse St, London SW3 6LY

Received 24 March 1998; accepted 18 May 1998

Abstract: The synthesis and pharmacological profile of a novel series of potent and selective phosphodiesterase type IV (PDE IV) inhibitors is described. © 1998 Elsevier Science Ltd. All rights reserved.

Asthma is a chronic, severe and all too often fatal disease the incidence of which is increasing.¹ A range of treatments are currently available based upon inhaled β -agonists² and steroids both of which offer only symptomatic relief and have associated side effects. There is an unmet medical need for an orally dosed anti-inflammatory agent, which treats the underlying disease, with a lower side effect profile than current therapies. Over the last decade, the inhibition of phosphodiesterase type IV (PDE IV) has emerged as an anti-inflammatory treatment for asthma.³ Indeed a vigorous pursuit of selective PDE IV inhibitors has resulted.⁴

A major concern that has arisen from the use of PDE IV inhibitors in clinical trials is the ability of these drugs to induce nausea and emetic side effects.⁵ The reasons for emesis have not been proven conclusively but evidence suggests that rolipram,⁶ a known PDE IV inhibitor, binds to the PDE IV enzyme at the catalytic site and a rolipram high-affinity binding site⁷ which is associated with the nausea and emetic side effects.^{4d} Since we believe that a selective PDE IV inhibitor would offer improved therapy with reduced side effects, we accordingly undertook a programme to identify compounds that would have potent PDE IV inhibitory activity but that would exhibit considerably lower inhibitory activity at the rolipram high-affinity binding site.

Compound **1** was identified by directed random screening and provided an exciting non-catechol based lead structure with a reasonably selectivity profile as defined above.⁸

Scheme 1 Initial Lead

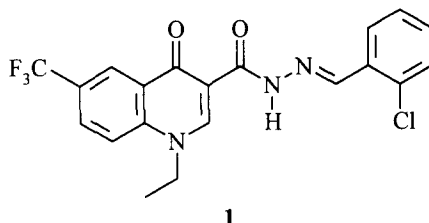

* E-mail: johnmontana@chiroscience.com Fax: +44 1223 420440

Quinolone-3-carboxylic acids have been utilised as antibacterial agents for some time.⁹ A variety of synthetic routes towards their synthesis has been investigated. The method of Kaminsky and Meltzer¹⁰ provided quinolone-3-carboxylic acids **6** as outlined in scheme 2. Condensation of anilines **2** with diethyl ethoxymethylenemalonate **3** followed by thermal cyclisation gave esters **4**, alkylation and hydrolysis of which gave carboxylic acids **6**. Alternatively, a number of these acids such as oxolinic acid, piromidic acid and flumequine, were commercially available, Scheme 3.

Scheme 2 Preparation of Quinolone-3-carboxylic acids

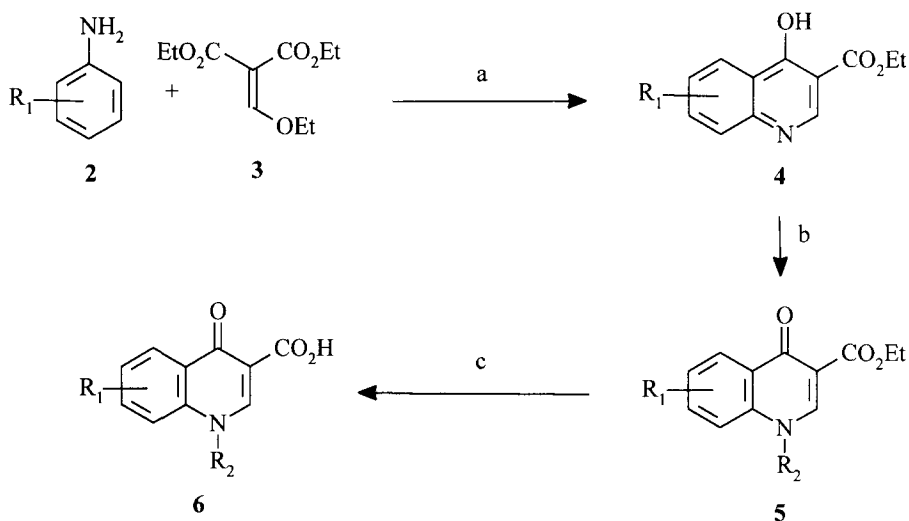

Reagents (a) i. 110°C, 3h ii. Ph₂, Ph₂O, 270°C; (b) NaH, DMF, R₂X; (c) LiOH.H₂O, THF, H₂O

Scheme 3 Commercially available Quinolone-3-carboxylic acids

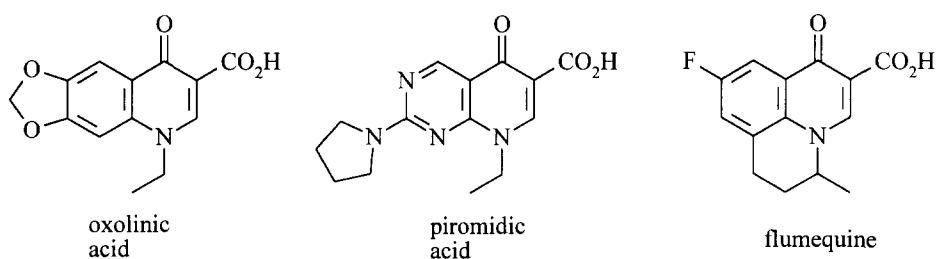

Amides **7** of these quinolone-3-carboxylic acids **6** were then generated via their mixed anhydrides as outlined in Scheme 4.

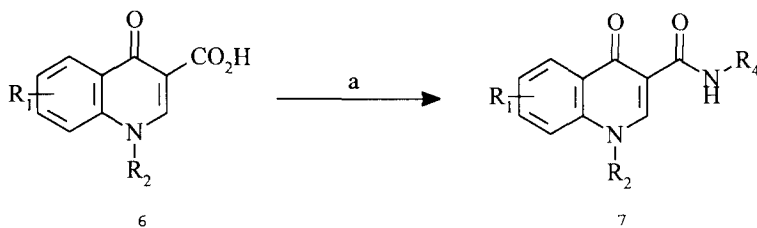
Scheme 4 Preparation of Amides

Reagents (a) i. isopropenylchloroformate, Et₃N, CH₂Cl₂ ii. H₂NR₄

A number of amides **7** were generated in this way, some of which are detailed in Table 1. Compound **8** was produced by direct N-methylation of **7a**. Compound **9**, however, was synthesized by first treating the corresponding ester **5** with phosphorus pentasulfide in refluxing pyridine to give the vinylogous thioamide. Hydrolysis of the ester followed by coupling with an amine as before gave compound **9**.

The compounds were evaluated initially in *in vitro* screens for PDE IV catalytic site activity¹¹ and high-affinity rolipram binding site activity¹² (RBA). As can be seen from Table 1 this series provides potent PDE IV inhibitors with an excellent PDE IV/RBA ratio.

The chain length linking the amide nitrogen to the aromatic ring could be quite varied with the conformationally constrained bicycles **7c** and **7e** being as active as their non-constrained analogues. Similarly the N-1 substituent could tolerate ethyl, propyl and cyclised flumequine derivatives as depicted by compounds **7b**, **7d** and **7g** respectively.

From the ¹H nmr spectra of these compounds it was evident that a strong H-bond existed between the amide N-H and the quinolone carbonyl, as illustrated in Scheme 5.

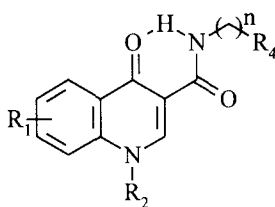
Scheme 5 Hydrogen Bonding Interaction

This interaction seems to be important since methylation of the amide nitrogen (compound **8**) greatly reduced the PDE IV potency. Exchanging sulfur for oxygen (compound **9**) gave a weaker H-bonding interaction as observed by nmr and one of the best *in vitro* PDE IV potencies in this series.

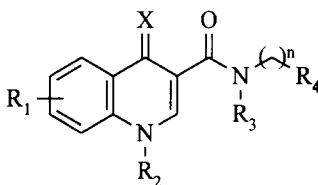
Table 1 *In Vitro* Biological Data

Compound	X	n	R ₁	R ₂	R ₃	R ₄	PDE IV IC ₅₀	RBA IC ₅₀	Ratio PDE IV/RBA
7a	O	2	6-CF ₃	Et	H	Ph	0.6μM	8% @ 1μM	<0.6
7b	O	2	6-CF ₃	Et	H	4-Pyridyl	1.5μM	24% @ 10μM	<0.15
7c	O	0	6-CF ₃	Et	H	1-(5,6-Dimethoxy indanyl)	0.9μM	22% @ 1μM	<0.9
7d	O	2	6-CF ₃	Pr	H	4-Pyridyl .HCl	1.7μM	10μM	0.17
7e	O	0	P*	Et	H	1-(5-Acetamido indanyl)	1.8μM	17% @ 1μM	<1
7f	O	2	P*	Et	H	4-Pyridyl	1.2μM	11% @ 1μM	<1
7g	O	2	F*	F*	H	4-Pyridyl	7μM	8% @ 10μM	<0.7
7h	O	2	O*	Et	H	4-Pyridyl	23μM	31% @ 10μM	~1
8	O	2	6-CF ₃	Et	Me	Ph	49μM	15% @ 100μM	<0.49
9	S	2	6-CF ₃	Et	H	4-Pyridyl	0.46μM	15% @ 1μM	<0.46

O* = oxolinic acid derivative.
 F* = flumequine derivative.
 P* = piromidic acid derivative.

Rolipram was used as an assay standard for the PDE IV (3.5μM) and RBA (25nM) assays. Initial lead compound 1 had a PDE IV IC₅₀ of 1.1μM and was inactive in the RBA assay at 10μM.

In order to investigate the *in vivo* efficacy of this series of compounds a number of the compounds were dosed in a guinea pig skin eosinophilia model.¹³ Compounds **7c**, **7e**, **7f**, **7g**, **7h** and **9** were each administered at 10mg/Kg po in this model. Each showed good activity across the range of mediators,¹⁴ as illustrated for compound **7g** in Table 2.

Table 2 Inhibition of Eosinophilia in the Guinea Pig by Oral Dosing of Compound **7g** at 10mg/Kg

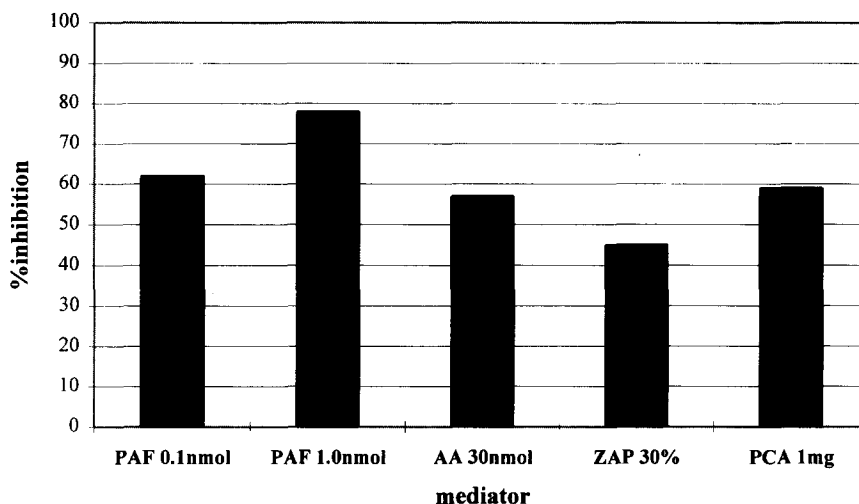

Compounds were also assessed for emetic and CNS side effects in a ferret emesis model.¹⁵ After oral administration of the compounds the animals were observed for signs of vomiting, retching, head burrowing, mouth scratching or salivation. Compound **7g** was clear of all side effects at 20mg/Kg. This compares favourably with rolipram which when administered orally shows inhibition of eosinophilia in the guinea pig skin model at 0.5 mg/Kg but is emetic in the ferret emesis model at 0.3mg/Kg.

Conclusions

We have identified a novel series of non-catechol based PDE IV inhibitors displaying good oral activity in a functional model of inflammation utilising a range of key mediators at doses which we have shown have no emetic side effects. Our strategy to further improve the enzyme potency and oral activity of this and other series of compounds will be the subject of future publications.

Acknowledgement

The authors thank Mr Philip Gilbert of the NMR department at Chiroscience for his work in carrying out variable temperature nmr experiments.

References and Notes

1. Higgs, G. *Chemistry and Industry* **1997**, 827-830.
2. Giembycz, M. A. *Trends Pharmacol. Sci.* **1996**, 17, 331-336.

3. (a) Teixeira, M. M.; Gristwood, R. W.; Cooper, N.; Hellewell, P. G. *Trends Pharmacol. Sci.* **1997**, *18*, 164-170 (b) de Brito, F. B.; Souness, J. E.; Warne, P. J. *Emerging Drugs* **1997**, *2*, 249-268.
4. (a) Hulme, C.; Poli, G. B.; Huang, F.-C.; Souness, J. E.; Djuric, S. W. *Bioorg. Med. Chem. Lett.* **1998**, *8*, 175-178 (b) Piaz, V. D.; Giovannoni, M. P.; Castellana, C.; Palacios, J. M.; Beleta, J.; Domenech, T.; Segarra, V. *J. Med. Chem.* **1997**, *40*, 1417-1421 (c) Chambers, R. J.; Marfat, A.; Cheng, J. B.; Cohan, V. L.; Damon, D. B.; Duplantier, A. J.; Hibbs, T. A.; Jenkinson, T. H.; Johnson, K. L.; Kraus, K. G.; Pettipher, E. R.; Salter, E. D.; Shirley, J. T.; Umland, J. P. *Bioorg. Med. Chem. Lett.* **1997**, *7*, 739-744 (d) Duplantier, A. J.; Biggers, M. S.; Chambers, R. J.; Cheng, J. B.; Cooper, K.; Damon, D. B.; Eggler, J. F.; Kraus, K. G.; Marfat, A.; Masamune, H.; Pillar, J. S.; Shirley, J. T.; Umland, J. P.; Watson, J. W. *J. Med. Chem.* **1996**, *39*, 120-125 (e) Stafford, J. A.; Valvano, N. L.; Feldman, P. L.; Brawley, E. S.; Cowan, D. J.; Domanico, P. L.; Leesnitzer, M. A.; Rose, D. A.; Stinson, S. A.; Strickland, A. B.; Unwalla, R. J.; Verghese, M. W. *Bioorg. Med. Chem. Lett.* **1995**, *5*, 1977-1982 (f) Masamune, H.; Cheng, J. B.; Cooper, K.; Eggler, J. F.; Marfat, A.; Marshall, S. C.; Shirley, J. T.; Tickner, J. E.; Umland, J. P.; Vazquez, E. *Bioorg. Med. Chem. Lett.* **1995**, *5*, 1965-1968 (g) Cheng, J. B.; Cooper, K.; Duplantier, A. J.; Eggler, J. F.; Kraus, K. G.; Marshall, S. C.; Marfat, A.; Masamune, H.; Shirley, J. T.; Tickner, J. E.; Umland, J. P. *Bioorg. Med. Chem. Lett.* **1995**, *5*, 1969-1972.
5. Zeller, E.; Stief, H. J.; Pflug, B.; Sastre, Y.; Hernandez, M. *Pharmacopsychiatry* **1988**, *59*, 358-369.
6. Schwabe, U.; Miyake, M.; Ohga, Y.; Daly, J. *Mol. Pharmacol.* **1976**, *12*, 900.
7. (a) Müller, T.; Engels, P.; Fozard, J. R. *Trends Pharmacol. Sci.* **1996**, *17*, 294-298 (b) Kelly, J. J.; Barnes, P. J.; Giembycz, M. A. *Biochem.* **1996**, *318*, 425-436 (c) Jacobitz, S.; McLaughlin, M. M.; Livi, G. P.; Burman, M.; Torphy, T. J. *Mol. Pharmacol.* **1996**, *50*, 891-899.
8. Initial lead compound **1** had a PDE IV IC₅₀ = 1.1 μM and was inactive in the RBA assay at 10 μM.
9. Wentland, M. P. *The New Generation of Quinolones*; Siporin, C.; Heifetz, C. L.; Domagala, J. M., Eds.; Marcel Dekker: New York, 1990; pp 1-43.
10. Kaminsky, D.; Meltzer, R. I. *J. Med. Chem.* **1968**, *11*, 160-164.
11. Thompson, W. J.; Terasaki, W. L.; Epstein, P. M.; Strada, S. J. *Adv. Cyclic Nucleotide Res.* **1979**, *10*, 69.
12. Schneider, H. H.; Schmeichen, R.; Brezinski, M.; Seidler, J. *Eur. J. Pharmacol.* **1997**, *127*, 105-115.
13. (a) Teixeira, M. M.; Reynia, S.; Robinson, M.; Shock, A.; Williams, F. M.; Rossi, A. G.; Hellewell, P. G. *Br. J. Pharmacol.* **1994**, *111*, 811-818 (b) Teixeira, M. M.; Williams, F. M.; Hellewell, P. G. *Br. J. Pharmacol.* **1993**, *110*, 416-422.
14. The mediators used as inflammagens in the guinea pig skin eosinophilia model were platelet aggregating factor (PAF), Arachidonic acid (AA) and zymosan-activated plasma (ZAP). Additionally sensitisation to bovine gamma globulin followed by an id challenge of antisera results in a passive cutaneous anaphylactic (PCA) response.
15. Costall, B.; Domeney, A. M.; Naylor, R. J.; Tattersall, F. D. *Neuropharmacology* **1987**, *26*, 1321-1326.

7-Methoxybenzofuran-4-carboxamides as PDE 4 Inhibitors: A Potential Treatment for Asthma

George Buckley,^a Nicola Cooper,^a Hazel J. Dyke,^a Fiona Galleway,^a Lewis Gowers,^a
Joanna C. Gregory,^a Duncan R. Hannah,^a Alan F. Haughan,^a Paul G. Hellewell,^b
Hannah J. Kendall,^a Christopher Lowe,^a Robert Maxey,^a John G. Montana,^{a,*}
Robert Naylor,^c C. Louise Picken,^a Karen A. Runcie,^a Verity Sabin,^a
Bishwa R. Tuladhar^b and Julie B. H. Warneck^a

^aCelltech-Chiroscience Ltd, Granta Park, Abington, Cambridge CB1 6GS, UK

^bDepartment of Pharmacology, National Heart and Lung Institute, Dovehouse St, London SW3 6LY, UK

^cDepartment of Pharmacology, University of Bradford, Bradford, BD7 1DP, UK

Received 17 April 2000; revised 12 July 2000; accepted 18 July 2000

Abstract—The synthesis and pharmacological profile of a novel series of 7-methoxybenzofuran-4-carboxamides is described. Some of these compounds were found to be potent inhibitors of phosphodiesterase type 4 (PDE4). © 2000 Elsevier Science Ltd. All rights reserved.

Phosphodiesterase type 4 (PDE4) is a cAMP-specific phosphodiesterase present in inflammatory cells and airway smooth muscle. It catalyses deactivation of cAMP by hydrolysis of the phosphodiester bond. The elevated levels of cAMP which result from inhibition of PDE4 cause activation of the protein kinases responsible for decreasing inflammatory cell activity and airway smooth muscle tone, leading to suppression of inflammatory cell functions and relaxation of airway smooth muscle.¹ These effects have prompted the investigation of PDE 4 inhibitors as a potential treatment for asthma.² The first selective PDE4 inhibitor to be identified was rolipram,³ which also caused side effects of nausea and emesis. It has been suggested that in addition to binding to the catalytic site on the enzyme, rolipram also binds to a high-affinity site (known as the rolipram binding site)⁴ and it is believed that binding to the high affinity site correlates with the emetic side effects.⁵ Modifications to the structure of rolipram have been carried out to identify compounds with the PDE4 inhibiting properties of rolipram but without the side effects, giving leads such as **RP 73401**, in which the pyrrolidinone moiety is replaced with 3,5-dichloropyridyl-4-carboxamide.⁶

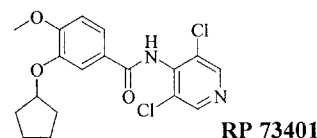
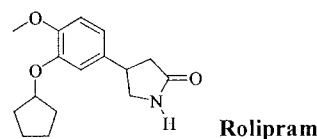

Our objective was to identify PDE4 inhibitors with good selectivity for the catalytic site over the rolipram binding site. Since inhibition of PDE3 may result in cardiotoxicity, selectivity for PDE4 over the PDE3 isozyme is also important.⁷

We have prepared a series of novel PDE4 inhibitors in which the 3,4-dialkoxyphenyl unit of **RP 73401** is replaced with a 7-methoxybenzofuran.⁸ A variety of substituents have been incorporated at the 2-position of the benzofuran to investigate their effect on potency and selectivity.

Following the procedure of René and Reyer,⁹ *o*-vanillin was reacted with the appropriate α -halo compounds in the presence of ethanolic potassium hydroxide to give the 2-substituted 7-methoxybenzofurans **1a**, **1e** and **1f**.

*Corresponding author. Tel.: +44-1223-896513; e-mail: johnmontana@chiroscience.com

1c and **1d** were obtained by Wolff–Kishner reduction of the corresponding carbonyl compounds. 7-Methoxybenzofuran-2-carboxylic acid **1g** was commercially available.¹⁰ Introduction of a carboxylic acid at the 4-position of the 2-substituted benzofurans **1a** and **1c–1g** was carried out either by bromination followed by carbonylation, or by formylation followed by oxidation. The resulting acids **2a** and **2c–2g** were converted to acid chlorides and then coupled with the anion of 4-amino-3,5-dichloropyridine (performed using sodium hydride in DMF) to give **3a** and **3c–3g** (Scheme 1). **3a** was reduced to the alcohol **3b** using sodium borohydride.

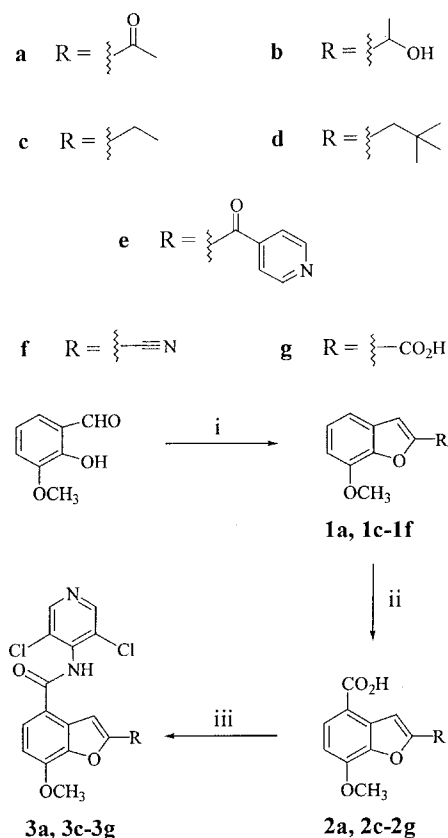

Scheme 1. Reagents: (i) XCH_2R , KOH, EtOH; (ii) Br_2 , MeOH, then CO, $\text{PdCl}_2(\text{PPh}_3)_2$, Et_3N , H_2O , THF or TiCl_4 , $\text{Cl}_2\text{CHOCH}_3$, then NaClO_2 , NaHPO_4 , $t\text{-BuOH}$; (iii) $\text{C}_2\text{Cl}_2\text{O}_2$, DMF, CH_2Cl_2 then 4-amino-3,5-dichloropyridine, NaH, DMF.

Table 1. 2-Substituted benzofuran-4-carboxamides^a

	PDE4 IC_{50} ¹¹	RBA IC_{50} ¹²	PDE4:RBA ^b	PDE3
Rolipram	3.5	0.02	175	27%
3a	0.0016	0.0434	0.037	32%
3b	0.0086	0.0188	0.46	23%
3c	0.027	0.023	1.17	46%
3d	0.017	0.075	0.23	34%
3e	0.00241	0.0081	0.30	7%
3f	0.0068	0.0065	1.05	31%
3g	0.77	1.65	0.47	38%

^aValues are shown as IC_{50} (μM) or percent inhibition at 20 μM and are the means of at least two experiments. RBA = rolipram binding assay.

^bPDE4 was obtained from human U937 cells, rolipram binding protein was obtained from rat brain tissues, and PDE3 was obtained from human platelets.

The 7-methoxybenzofuran-4-carboxamides **3a–3g** were screened in in vitro assays (Table 1).

The 2-acetylbenzofuran **3a** was found to be the best compound in the series **3a–3g**. It was a potent inhibitor of PDE4, showed excellent selectivity for the catalytic site over the rolipram binding site, and was inactive against PDE3. The alcohol **3b** was also a potent inhibitor of PDE4, but its ratio of binding to the catalytic site compared with binding to the rolipram site was not as good as that of the ketone **3a**. The ethyl compound **3c** was 10-fold less potent than the ketone **3a**, illustrating the need for a hydrogen-bonding group at the 2-position for optimal activity. Replacing the cyclopentyl group in rolipram with bulky lipophilic substituents has been reported to improve the PDE4:RBA ratio,¹³ but in this series the 2,2-dimethylpropyl compound **3d** was found to be 10-fold less selective than the 2-acetyl compound **3a**. The pyridylcarbonyl compound **3e** and the nitrile **3f** were both very potent inhibitors of PDE4, but their PDE4:RBA ratios were not satisfactory. The carboxylic acid **3g** had little PDE4 inhibitory activity.

Having identified the 2-acetyl-7-methoxybenzofuran **3a** as a potent selective inhibitor of PDE4, we went on to investigate the effect of methylating the amide nitrogen and the 3-position of the benzofuran ring on potency and selectivity. The *N*-methyl and 3-methyl analogues of **3a** (**4** and **5** respectively) were prepared and screened in in vitro assays. They showed only modest PDE4 inhibitory activity (Table 2).

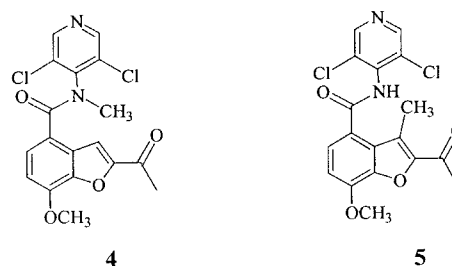

We also investigated the effect of replacing the 3,5-dichloropyridyl moiety with other substituted 6-membered aromatic rings. A variety of aromatic amines were coupled

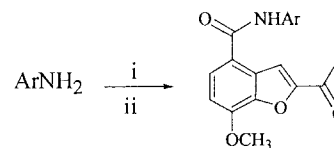

Scheme 2. Reagents: (i) NaH, DMF; (ii) 2-acetyl-7-methoxybenzofuran.

Table 2. Methylated 2-acetylbenzofuran-4-carboxamides^a

	PDE4 IC_{50} ¹¹	RBA IC_{50} ¹²
4	0.33	0.15
5	0.32	0.16

^aValues are shown as IC_{50} (μM) and are the means of at least two experiments. RBA = rolipram binding assay.

Table 3. *N*-Heterocyclic 2-acetylbenzofuran-4-carboxamides^a

	Ar	PDE4 IC ₅₀ ¹¹	RBA IC ₅₀ ¹²	PDE4:RBA
3a	3,5-Dichloropyrid-4-yl	0.0016	0.0434	0.037
6a	3-Chloropyrid-4-yl	0.0063	0.032	0.197
6b	Pyrid-4-yl	0.12	0.25	0.48
6c	2-Chloropyrid-3-yl	0.875	0.199	4.40
6d	3-Methylpyrid-2-yl	0.452	1.85	0.24
6e	5-Chloropyrimidin-4-yl	0.164	0.0596	2.75
6f	2-Chlorophenyl	0.054	0.248	0.21
6g	2,6-Dichloro-4-cyanophenyl	0.0851	0.228	0.37

^aValues are shown as IC₅₀ (μM) and are the means of at least two experiments. RBA = rolipram binding assay.

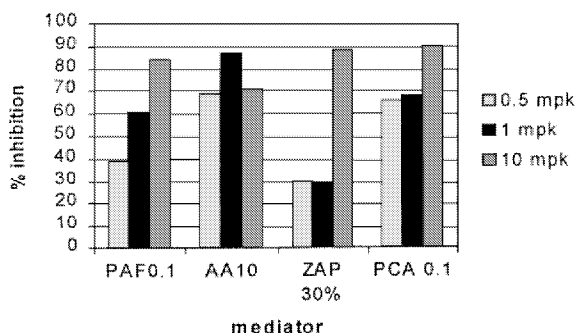

Figure 1. Inhibition of eosinophilia in the guinea pig by oral dosing of **3a**. Values are shown are the means of two experiments.

with 2-acetyl-7-methoxybenzofuran 4-carboxylic acid (Scheme 2) to give the compounds **6a–6h**, which were screened in in vitro assays as described above (Table 3).

The monochloropyridyl compound **6a** was almost as potent as the dichloro analogue **3a**, but its ratio was inferior. The pyridyl compound **6b** was much less active, indicating that for good activity against PDE4 it was essential to have at least one substituent *ortho* to the amide bond. Moving the pyridine nitrogen around the ring as in **6c** and **6d** was also detrimental. Location of the pyridine nitrogen *meta* to the amide bond (**6c**) resulted in selectivity for the rolipram binding site over the catalytic site, as did incorporation of a second nitrogen into the ring as in the pyrimidine **6e**. Removing the pyridine nitrogen (**6f**) caused a 10-fold drop in activity. A nitrile substituent *para* to the amide bond was tolerated, but the 4-cyano-2,6-dichlorophenyl compound **6g** was neither as active nor as selective as the corresponding dichloropyridyl compound **3a**.

On the basis of its high potency against PDE4 and good selectivity for the catalytic site over the rolipram binding site, compound **3a** was selected for evaluation in a guinea pig skin eosinophilia model.¹⁴ It was administered po at 0.5, 1 and 10 mpk, and showed good activity across a range of mediators¹⁵ as shown in Figure 1.

3a was also assessed for emetic and CNS side effects in a ferret emesis model.¹⁶ Neither emesis nor CNS effects were observed when **3a** was dosed orally at 10 mpk indicating that there is a significant difference between the efficacious and emetic doses for this compound.

In summary, we have identified a series of novel benzo-

furan based PDE4 inhibitors. The 2-acetyl compound **3a** showed good oral activity in a functional model of inflammation at doses which showed none of the CNS and emetic side effects associated with the prototypical PDE4 inhibitor, rolipram. Work is now in progress to optimise this lead.

References and Notes

- Nicolson, C. D.; Shahid, M. Pulmon. *Pharmacol.* **1994**, *7*, 1; Palacios, J. M.; Beleta, J.; Segarra, V. *Il Farmaco* **1995**, *50*, 819.
- (a) Cavalla, D.; Frith, R. *Current Medicinal Chemistry* **1995**, *2*, 561. (b) DeBrito, F. B.; Souness, J. E.; Warne, P. J.; *Emerging Drugs* **1997**, *2*, 249.
- Scwabe U.; Miyake M.; Ohga Y.; Daly J. *Mol. Pharmacol.* **1976**, *12*, 900.
- (a) Muller, T.; Engels, P.; Fozard, J. R. *Trends Pharmacol. Sci.* **1996**, *17*, 294. (b) Kelly, J. J.; Barnes, P. J.; Giembycz, M. A. *Biochem.* **1996**, *318*, 425. (c) Jacobitz, S.; McLaughlin, M. M.; Livi, G. P.; Burman, M.; Torphy, T. J. *Mol. Pharmacol.* **1996**, *50*, 891.
- Duplantier, A. J.; Biggers, M. S.; Chambers, R. J.; Cheng, J. B.; Cooper, K.; Damon, D. B.; Eggler, J. F.; Kraus, K. G.; Marfat, A.; Masamune, H.; Pillar, J. S.; Shirley, J. T.; Umland, J. P.; Watson, J. W. *J. Med. Chem.* **1996**, *39*, 120.
- Ashton, M. J.; Cook, D. C.; Fenton, G.; Karlsson, J.-A.; Palfreyman, M. N.; Raeburn, D.; Ratcliff, A. J.; Souness, J. E.; Thurairatnam, S.; Vicker, N. *J. Med. Chem.* **1994**, *37*, 1696.
- Demoliou-Mason, C. D.; *Exp. Opin. Ther. Patents* **1995**, *5*, 417.
- The use of benzofuran rings to replace the 3,4-dialkoxy subunit of rolipram has also been reported Rhone-Poulenc Rorer: McGarry, D. G.; Regan, J. R.; Volz, F. A.; Hulme, C.; Moriarty, K. J.; Djuric, S. W.; Souness, J. E.; Miller, B. E.; Travis, J. J.; Sweeney, D. M. *Bioorg. Med. Chem.* **1999**, *7*, 1131.
- René, L.; Reyer, R. *B. Soc. Chim. Fr* **1971**, *12*, 4329.
- Transworld Chemicals Inc.
- Thompson, W. J.; Terasaki, W. L.; Epstein, P. M.; Strada, S. *J. Adv. Cyclic Nucleotide Res.* **1979**, *10*, 69.
- Schneider, H. H.; Schmeichen, R.; Brezinski, M.; Seidler, J. *Eur. J. Pharmacol.* **1997**, *127*, 105.
- Cheng, J. B.; Cooper, K.; Duplantier, A. J.; Eggler, J. F.; Kraus, K. G.; Marshall, S. C.; Marfat, A.; Masamune, H.; Shirley, J. T.; Tickner, K. E.; Umland, J. P. *Bioorg. Med. Chem Lett.* **1995**, *5*, 1969.
- (a) Teixeira, M.M.; Reyna, S.; Robinson, M.; Shock, A.; Williams, T. J.; Williams, F. M.; Rossi, A. G.; Hellewell, P. G.

Br. J. Pharmacol. **1994**, *111*, 811. (b) Teixeira, M.M.; Williams, T. J.; Hellewell, P. G. *Br. J. Pharmacol.* **1993**, *110*, 416.
15. The mediators used as inflammagens in the guinea pig skin eosinophilia model were platelet aggregating factor (PAF) at

0.1 nmol, arachidonic acid (AA) at 10 nmol, and zymosan-activated plasma (ZAP) at 30%. Sensitisation to 0.1 µg of bovine gammaglobulin followed by an id challenge of antisera results in a passive cutaneous anaphylactic (PCA) response.
16. Costall, B.; Domeney, A. M.; Naylor, R. J.; Tattersall, F. D. *Neuropharmacology* **1987**, *26*, 1321.



Pergamon

Bioorganic & Medicinal Chemistry Letters 12 (2002) 509–512

BIOORGANIC &
MEDICINAL
CHEMISTRY
LETTERS

7-Methoxyfuro[2,3-*c*]pyridine-4-carboxamides as PDE4 Inhibitors: A Potential Treatment for Asthma

George M. Buckley, Nicola Cooper, Richard J. Davenport, Hazel J. Dyke, Fiona P. Galleway, Lewis Gowers, Alan F. Haughan, Hannah J. Kendall, Christopher Lowe, John G. Montana, Janet Oxford, Joanna C. Peake, C. Louise Picken, Marianna D. Richard, Verity Sabin, Andrew Sharpe* and Julie B. H. Warneck

Celltech R & D, Granta Park, Great Abington, Cambridge CB1 6GS, UK

Received 7 September 2001; revised 12 November 2001; accepted 20 November 2001

Abstract—The synthesis and pharmacological profile of a novel series of 7-methoxy-furo[2,3-*c*]pyridine-4-carboxamides is described. Some of these compounds were found to be potent inhibitors of phosphodiesterase type 4 (PDE4). Initial © 2002 Elsevier Science Ltd. All rights reserved.

Phosphodiesterase type 4 (PDE4) is a cAMP-specific phosphodiesterase present in inflammatory cells and airway smooth muscle. It catalyses deactivation of cAMP by hydrolysis of the phosphodiester bond. The elevated levels of cAMP which result from inhibition of PDE4 cause activation of the protein kinases responsible for decreasing inflammatory cell activity and airway smooth muscle tone. This leads to suppression of inflammatory cell functions and relaxation of airway smooth muscle.¹ These effects have prompted the investigation of PDE4 inhibitors as a potential treatment for asthma.² The first selective PDE4 inhibitor to be identified was *rolipram*,³ which also caused side effects of nausea and emesis. It has been postulated that in addition to binding to the catalytic site on the enzyme, *rolipram* also binds to a high affinity site (known as the *rolipram* binding site)⁴ and it is believed that the emetic side effects correlate with this binding.⁵ Modifications to the structure of *rolipram* have been carried out to identify novel PDE4 inhibitors devoid of side effects. To date, the most advanced PDE4 inhibitor is *cilomilast* (Ariflo, SB-207499), which is now in phase III trials in the clinic.⁶

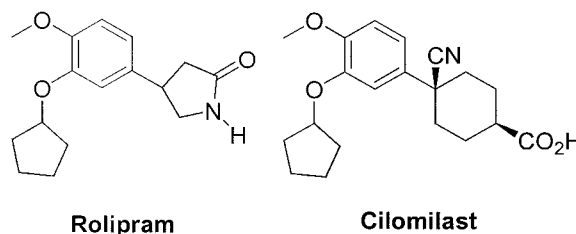

Our objective was to identify PDE4 inhibitors with good selectivity for the catalytic site over the *rolipram* binding site. Since inhibition of PDE3 may result in cardiotoxicity, selectivity for PDE4 over the PDE3 isozyme is also important.⁷

The preparation of a series of PDE4 inhibitors in which the 3,4-dialkoxyphenyl unit is replaced with a 7-methoxybenzofuran has been previously reported.^{8,9} Here we describe the replacement of the 7-methoxybenzofuran with 7-methoxyfuro[2,3-*c*]pyridine to generate a novel series of inhibitors. Incorporation of the nitrogen atom was intended to improve the pharmacokinetic properties of this series over the benzofurans. A variety of substituents have been incorporated at the 2-position of the furopyridine to investigate their effect on potency and selectivity. Some work has also been undertaken to investigate the effect of replacing the 3,5-dichloropyridyl with other six-membered aromatic rings.

*Corresponding author. Fax: +44-1223-896400;
e-mail: andrewsharpe@celltechgroup.com

Following the procedure of Shiotani and Morita,¹⁰ commercially available furan-3-acrylic acid **1** was treated with isobutyl chloroformate and triethylamine in acetone to give a mixed anhydride, which was converted to acyl azide **2** by reaction with sodium azide. Heating acyl azide **2** with tributylamine in diphenylmethane at 180 °C afforded furo[2,3-*c*]pyridin-7(6*H*)-one **3**. This was converted to the desired 7-methoxyfuro[2,3-*c*]pyridine **4** via the 7-chloro derivative by refluxing with phosphorus oxychloride followed by treatment with sodium methoxide in 1,4-dioxane (Scheme 1).

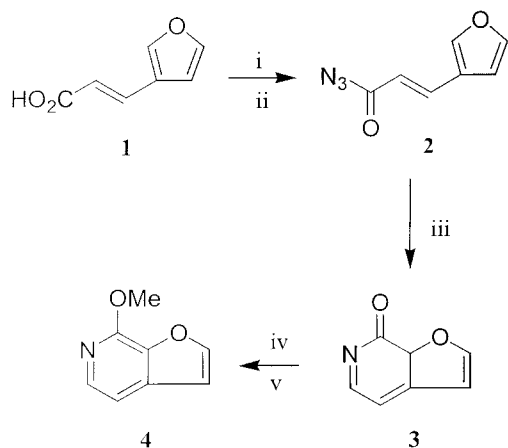

Scheme 1. Reagents and conditions: (i) $\text{ClCO}_2\text{CH}_2\text{CH}_2(\text{CH}_3)_2$, NEt_3 , acetone; (ii) NaN_3 , H_2O ; (iii) NBu_3 , Ph_2CH_2 , 180 °C; (iv) POCl_3 ; (v) NaOMe , 1,4-dioxane.

The preparation of the required 2-substituted furo[2,3-*c*]pyridines was achieved in a variety of ways. Treatment of 7-methoxyfuro[2,3-*c*]pyridine **4** with *n*-butyl lithium and ethyl iodide afforded 2-ethyl-7-methoxyfuro[2,3-*c*]pyridine **5a**. Forming the anion at the 2-position of the furo[2,3-*c*]pyridine in the same way and subsequent treatment with formaldehyde followed by reaction

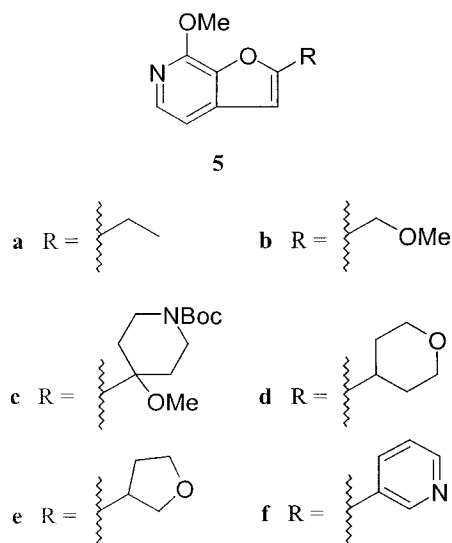

with methyl iodide and sodium hydride gave the methoxymethyl analogue **5b**. Similarly using *N*-Boc-protected 4-piperidinone as the electrophile resulted in 4-methoxy-4-(7-methoxyfuro[2,3-*c*]pyridin-2-yl)-piperidine-1-carboxylic acid *tert*-butyl ester **5c**. The cyclic ethers **5d** and **5e** were prepared using tetrahydro-4*H*-pyran-4-one and dihydrofuran-3-one respectively in the initial anion reaction. Treatment with mesyl chloride and triethylamine followed by hydrogenation using Raney nickel gave the desired products. 2-Bromofuro[2,3-*c*]pyridine was prepared by reaction of the anion with bromine. This intermediate was converted to the 2-pyridyl derivative **5f** via a palladium-catalysed Suzuki reaction with (3-pyridyl)-borane.

Once the 2-substituent was in place, the various intermediates were further elaborated to the desired final compounds using the same set of reaction conditions. Thus, the 4-bromo-7-methoxy-furo[2,3-*c*]pyridines **6** were prepared by treatment of compounds **5** with *N*-bromosuccinimide. Carbonylation followed by 4-nitrophenyl ester formation afforded key intermediates **7**. These were coupled with the anion of 4-amino-3,5-dichloropyridine-*N*-oxide (preformed using sodium hydride in DMF) to give our novel series of test compounds **8** (Scheme 2).

These were screened in our *in vitro* assay (Table 1).

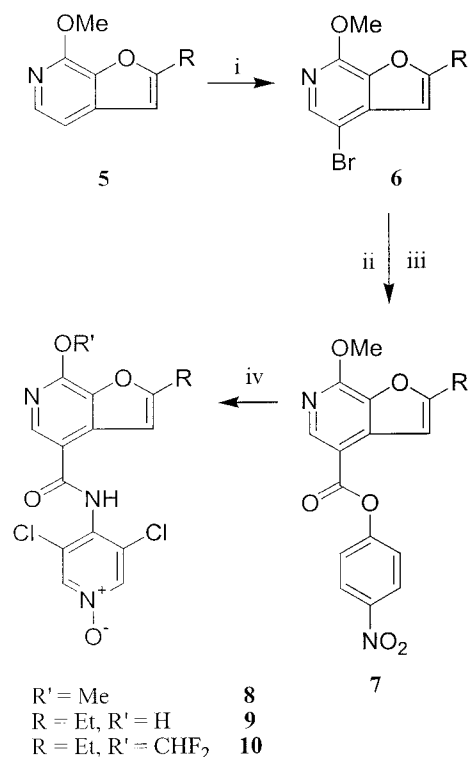

Scheme 2. Reagents and conditions: (i) NBS, MeCN; (ii) CO, $\text{Pd}(\text{OAc})_2$, bis-diphenylphosphinopropane, NEt_3 , THF, H_2O ; (iii) *p*-nitrophenol, EDC·HCl, DMAP, CH_2Cl_2 ; (iv) 4-amino-3,5-dichloropyridine-*N*-oxide, NaH, DMF.

Table 1. 2-Substituted furo[2,3-*c*]pyridines^a

	PDE4 IC ₅₀ ¹¹	RBA IC ₅₀ ¹²	PDE4/RBA	PDE3 ^b (%)
Rolipram	3.5	0.02	175	27
8a	0.014	0.084	0.16	32
8b	0.047	0.280	0.17	1A
8c	0.048	1.01	0.05	1A
8d	0.047	0.295	0.16	3
8e	0.023	0.151	0.15	NT
8f	0.062	0.621	0.10	NT

^aValues are shown as IC₅₀ (μM) or percent inhibition at 20 μM and are the means of at least two experiments. RBA, rolipram binding assay.

^bPDE4 was obtained from human U937 cells, rolipram binding protein was obtained from rat brain tissues and PDE3 was obtained from human platelets.

As can be seen, a wide variety of substituents are tolerated at the 2-position of the furo[2,3-*c*]pyridine giving a novel series of potent and selective PDE4 inhibitors. The most potent compound with acceptable selectivity over binding at the rolipram site was found to be 2-ethyl-7-methoxyfuro[2,3-*c*]pyridine-4-carboxylic acid (3,5-dichloro-1-oxopyridin-4-yl)amide **8a**.

Having identified the 2-ethyl derivative **8a** as a potent, selective inhibitor of PDE4 we investigated the effect of the 7-methoxy substituent. Removing the methyl group to give the furo[2,3-*c*]pyridin-7(6*H*)-one analogue **9** resulted in a dramatic decrease in activity. However replacing the 7-methoxy moiety with a 7-difluoromethoxy substituent to give compound **10** enhanced the potency of this series of inhibitors (Table 2).

Table 2. 7-Substituted furo[2,3-*c*]pyridines^a

	PDE4 IC ₅₀ ¹¹	RBA IC ₅₀ ¹²	PDE4/RBA	PDE3
8a	0.014	0.084	0.16	32%
9	22%	61%	NA	NT
10	0.0037	0.028	0.13	NT

^aValues are shown as IC₅₀ (μM) or percent inhibition at 1 μM and are the means of at least two experiments. RBA, rolipram binding assay.

Moving on to investigate the effect of replacing the 3,5-dichloropyridinyl-*N*-oxide moiety with other substituted six-membered aromatic rings, a variety of aromatic amines were coupled with 2-ethyl-7-methoxyfuro[2,3-*c*]pyridine-4-carboxylic acid 4-nitrophenyl ester **7a** in the way previously described (Scheme 3). A series of compounds **11** were thus prepared (Scheme 3) and tested in our in vitro assay (Table 3).

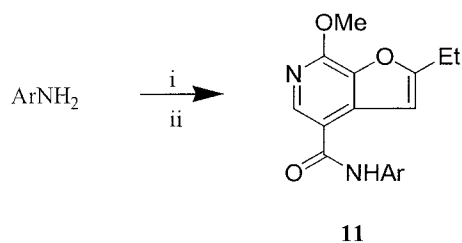

Scheme 3. Reagents and conditions: (i) NaH or NaHMDS, DMF; (ii) 2-ethyl-7-methoxyfuro[2,3-*c*]pyridine-4-carboxylic acid 4-nitrophenyl ester **7a**.

Table 3. *N*-Heterocyclo-2-ethylfuro[2,3-*c*]pyridinyl-4-carboxamides^a

	PDE4 IC ₅₀ ¹¹	RBA IC ₅₀ ¹²	PDE4/RBA	PDE3 ^b (%)
8a	0.014	0.084	0.16	32%
11a	0.12	0.28	0.45	39%
11b	0.12	0.35	0.33	NT
11c	21%	NT	NA	NT
11d	0.14	0.27	0.49	1A
11e	0.066	0.27	0.24	NT
11f	0.23	0.58	0.39	NT

^aValues are shown as IC₅₀ (μM) or percent inhibition at 1 μM for PDE4 and 20 μM for PDE3 and are the means of at least two experiments. RBA, rolipram binding assay.

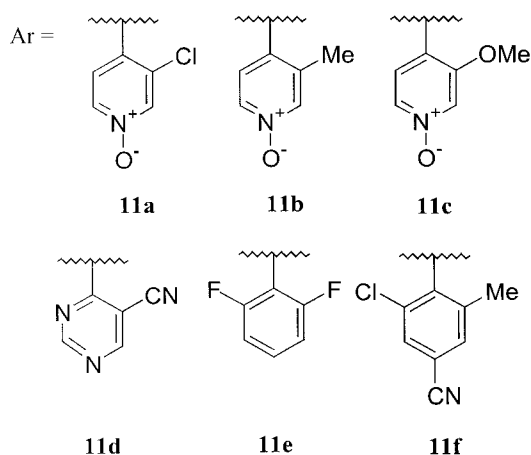

Removal of one chloro substituent from the parent compound to give **11a** resulted in a 10-fold drop in activity against PDE4 as well as reducing the selectivity for catalytic activity over binding to the rolipram site. A similar effect was seen by replacing the chloro substituent with a methyl group as in compound **11b**. However the 3-methoxy analogue **11c** had dramatically reduced potency against PDE4. Incorporating a second nitrogen in the ring as in the 5-cyanopyrimidin-4-yl example **11d** gave a compound with a very similar activity and selectivity profile to the mono-substituted pyridines **11a** and **11b**. Reasonably potent and selective inhibition could be achieved after removing the pyridine nitrogen as exemplified by **11e** and **11f**. However, 2-ethyl-7-methoxy-furo[2,3-*c*]pyridine-4-carboxylic acid (3,5-dichloro-1-oxopyridin-4-yl)amide **8a** remained our most potent and selective compound in this series.

Given this high potency and selectivity, this compound was selected for in vivo studies. Pharmacokinetic studies in the guinea pig dosing at 3 mg/kg po showed a C_{max} of 1411 ng/mL and an AUC of 4942 ng h/mL. The bio-availability was found to be 54%. Using the same dosing, the corresponding benzofuran analogue showed a C_{max} of 311 ng/mL and an AUC of 1394 ng h/mL. Thus incorporation of the ring nitrogen has improved the pharmacokinetics as predicted. The compound was then evaluated in a guinea pig lung eosinophilia model.¹³ Administering po at 10 mg/kg, the compound showed 40% inhibition of lung eosinophilia (mean result of three experiments).

In summary, we have identified a series of novel furo[2,3-*c*]pyridines as potent and selective PDE4 inhibitors with a good pharmacokinetic profile. Significant levels of oral activity were demonstrated in a functional model of inflammation.

References and Notes

1. (a) Nicolson, C. D.; Shahid, M. *Pulmon. Pharmacol.* **1994**, *7*, 1. (b) Palacios, J. M.; Beleta, J.; Segarra, V. *Il Farmaco* **1995**, *50*, 819.
2. (a) Cavalla, D.; Frith, R. *Current Medicinal Chemistry* **1995**, *2*, 561. (b) DeBrito, F. B.; Souness, J. E.; Warne, P. J. *Emerging Drugs* **1997**, *2*, 249.
3. Scwabe, U.; Miyake, M.; Ohga, Y.; Daly, J. *Mol. Pharmacol.* **1976**, *12*, 900.
4. (a) Muller, T.; Engels, P.; Fozard, J. R. *Trends Pharmacol. Sci.* **1996**, *17*, 294. (b) Kelly, J. J.; Barnes, P. J.; Giembycz, M. A. *Biochemistry* **1996**, *318*, 425. (c) Jacobitz, S.; McLaughlin, M. M.; Livi, G. P.; Burman, M.; Torphy, T. J. *Mol. Pharmacol.* **1996**, *50*, 891. (d) Souness, J. E.; Aldous, D.; Sargent, C. *Immunopharmacology* **2000**, *47*, 127.
5. Duplantier, A. J.; Biggers, M. S.; Chambers, R. J.; Cheng, J. B.; Cooper, K.; Damon, D. B.; Eggler, J. F.; Kraus, K. G.; Marfat, A.; Masamune, H.; Pillar, J. S.; Shirley, J. T.; Umland, J. P.; Watson, J. W. *J. Med. Chem.* **1996**, *39*, 120.
6. Giembycz, M. A. *Expert Opin. Invest. Drugs* **2001**, *10*, 1361.
7. Demoliou-Mason, C. D. *Exp. Opin. Ther. Patents* **1995**, *5*, 417.
8. McGarry, D. G.; Regan, J. R.; Volz, F. A.; Hulme, C.; Moriarty, K. J.; Djuric, S. W.; Souness, J. E.; Miller, B. E.; Travis, J. J.; Sweeney, D. M. *Bioorg. Med. Chem.* **1999**, *7*, 1131.
9. Buckley, G.; Cooper, N.; Dyke, H. J.; Galleway, F.; Gowers, L.; Gregory, J. C.; Hannah, D. R.; Haughan, A. F.; Hellewell, P. G.; Kendall, H. J.; Lowe, C.; Maxey, R.; Montana, J. G.; Naylor, R.; Picken, C. L.; Runcie, K. A.; Sabin, V.; Tuladhar, B. R.; Warneck, J. B. H. *Bioorg. Med. Chem. Lett.* **2000**, *10*, 2137.
10. Shiotani, S.; Morita, H. *J. Heterocyclic Chem.* **1982**, *19*, 1207.
11. Thompson, W. J.; Terasaki, W. L.; Epstein, P. M.; Strada, S. J. *Adv. Cyclic Nucleotide Res.* **1979**, *10*, 69.
12. Schneider, H. H.; Schmeichen, R.; Brezinski, M.; Seidler, J. *Eur. J. Pharmacol.* **1997**, *127*, 105.
13. (a) Mauser, P. J.; Pitman, A.; Witt, A.; Fernandez, X.; Zurcher, J.; Kung, T.; Jones, H.; Watnick, A. S.; Egan, R. W.; Kreutner, W.; Adams, G. K., III. *Am. Rev. Respir. Dis.* **1993**, *148*, 1623. (b) Mauser, P. J.; Pitman, A. M.; Fernandez, X.; Foran, S. K.; Adams, G. K., III.; Kreutner, W.; Egan, R. W.; Chapman, R. W. *Am. J. Respir. Crit. Care Med.* **1995**, *152*, 467.



Pergamon

Bioorganic & Medicinal Chemistry Letters 12 (2002) 1613–1615

BIOORGANIC &
MEDICINAL
CHEMISTRY
LETTERS

8-Methoxyquinoline-5-carboxamides as PDE4 Inhibitors: A Potential Treatment for Asthma

George M. Buckley,^a Nicola Cooper,^a Hazel J. Dyke,^a Fiona P. Galleway,^a
Lewis Gowers,^a Alan F. Haughan,^a Hannah J. Kendall,^a Christopher Lowe,^a
Robert Maxey,^a John G. Montana,^a Robert Naylor,^b Janet Oxford,^a Joanna C. Peake,^a
C. Louise Picken,^a Karen A. Runcie,^a Verity Sabin,^a Andrew Sharpe^{a,*}
and Julie B. H. Warneck^a

^aCelltech R&D, Granta Park, Great Abington, Cambridge CB1 6GS, UK
^bDepartment of Pharmacology, University of Bradford, Bradford BD7 1DP, UK

Received 8 March 2002; accepted 4 April 2002

Abstract—A series of bicyclic heteroaryl ring systems was considered as a replacement for the 3-cyclopentyloxy-4-methoxyphenyl moiety in rolipram resulting in the discovery of 8-methoxyquinoline-5-carboxamides as potent inhibitors of phosphodiesterase type 4 (PDE4). © 2002 Elsevier Science Ltd. All rights reserved.

Phosphodiesterase enzymes are responsible for the inactivation of cyclic adenosine monophosphate (cAMP) and cyclic guanosine monophosphate (cGMP). Phosphodiesterase 4 (PDE4) is a cAMP specific phosphodiesterase expressed in inflammatory cells, such as eosinophils, and airway smooth muscle. Inhibition of PDE4 results in an elevation of cAMP, which in turn downregulates the inflammatory response.¹ The potential use of PDE4 inhibitors as anti-inflammatory agents for the treatment of asthma has received considerable interest from the pharmaceutical industry.² Early PDE4 inhibitors typified by *rolipram*³ caused dose-limiting side effects, such as nausea and emesis. Recent evidence suggests a correlation between these side effects and the ability to bind at the so-called high affinity rolipram binding site,⁴ whilst beneficial effects appear to correlate with binding at the catalytic site.⁵ Modifications to the structure of rolipram have been carried out to identify novel PDE4 inhibitors devoid of side effects. To date, the most advanced PDE4 inhibitors are cilomilast (Ari-flo, SB-207499) and roflumilast (Byk Gulden), which are now in phase III trials in the clinic.⁶

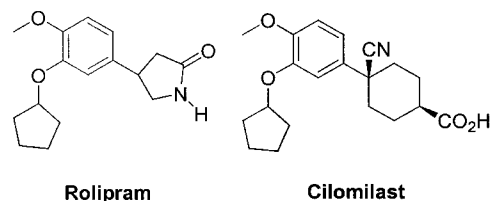

Our objective was to identify PDE4 inhibitors with good selectivity for the catalytic site over the high affinity rolipram binding site. Since inhibition of PDE3 may result in cardiotoxicity, selectivity for PDE4 over the PDE3 isozyme is also important.⁷

Our first replacement for the 3,4-dialkoxyphenyl unit in rolipram was the 7-methoxybenzofuran moiety. To investigate the effect of this change, a series of 2-substituted 7-methoxybenzofuran-4-carboxylic acid (3,5-dichloropyridin-4-yl)amides was prepared and screened in our in vitro assays. These results have been reported in an earlier publication.⁸ The best compound from this series in terms of activity and selectivity was the 2-acetyl derivative **1** (Table 1).

As can be seen, a very potent, selective inhibitor of PDE4 was obtained by making this replacement. However, despite being efficacious in the guinea pig skin model,¹¹ this compound was found to have a poor pharmacokinetic profile. Other examples from this series

*Corresponding author. Fax: +44-1223-896400; e-mail: andrewsharpe@celltechgroup.com

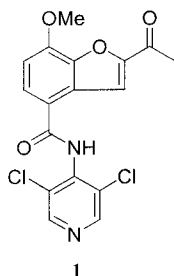
Table 1. Rolipram versus 2-acetylbenzofuran^a

	PDE4 IC ₅₀ ⁹	RBA IC ₅₀ ¹⁰	PDE4/RBA	PDE3 ^b (%)
Rolipram	3.5	0.02	175	27
1	0.001	0.02	0.05	32

^aValues are shown as IC₅₀ (μM) or percent inhibition at 20 μM and are the means of at least two experiments. RBA, rolipram binding assay. ^bPDE4 was obtained from human U937 cells, rolipram binding protein was obtained from rat brain tissues and PDE3 was obtained from human platelets.

had similar drawbacks. Further modifications to the 2-substituent of the 7-methoxybenzofuran-4-carboxamide series are reported elsewhere.¹² Similarly our attempts to improve the pharmacokinetic profile by incorporation of a nitrogen atom into the benzofuran ring system to give a novel series of 2-ethyl-7-methoxyfuro[2,3-*c*]pyridine-4-carboxamides are reported in a separate publication.¹³

In view of the disappointing pharmacokinetic properties of the benzofurans, alternative biaryl heterocycles were considered as replacements. It was thought that incorporating one or more nitrogens in the ring system would improve the solubility and hence the pharmacokinetics. Therefore the first replacement considered was the benzimidazole. Various 2- and 3-substituted analogues were prepared giving a series of 7-methoxybenzimidazole-4-carboxylic acid (3,5-dichloropyridin-4-yl)amides **2**.

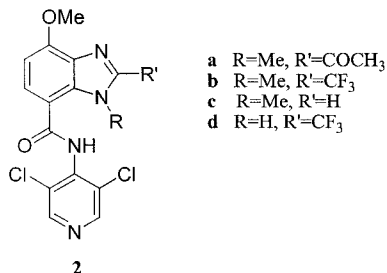
Table 2. Benzimidazoles^a

	PDE4 IC ₅₀ ⁹	RBA IC ₅₀ ¹⁰	PDE4/RBA	PDE3 (%)
2a	0.48	0.20	2.4	NT
2b	0.29	0.46	0.63	11
2c	IA	NT	NA	NT
2d	0.12	0.02	6	43

^aValues are shown as IC₅₀ (μM) or percent inhibition at 20 μM and are the means of at least two experiments. RBA, rolipram binding assay; IA, inactive; NT, not tested; NA, not applicable.

These compounds were tested in our in vitro assays (Table 2).

From these results it would appear that a 2-substituent is essential for activity against PDE4. Unfortunately even the 2-substituted 7-methoxybenzimidazoles are only moderately potent PDE4 inhibitors compared to the 2-substituted benzofuran **1**. Also the PDE4 activity to rolipram binding ratio is not acceptable and in many cases favoured rolipram binding. Thus this series of benzimidazoles was not investigated further.

However, the pharmacokinetic profile of the benzimidazoles had been found to be an improvement over that of the benzofurans. Therefore we were encouraged to consider other nitrogen-containing systems, such as quinolines. A series of 8-methoxyquinoline-4-carboxamides **3** was prepared and screened in our in vitro assays to examine the effect of this replacement and to explore substitution on the pyridin-4-yl moiety (Table 3).

Clearly, the unsubstituted pyridine analogue **3a** does not reach the required levels of potency against PDE4. However, despite not being as potent as many of the benzofurans, both the mono- and dichloro-substituted 8-methoxyquinoline-4-carboxylic acid (pyridyl-4-yl)amides **3b,3c** have acceptable levels of activity against PDE4. In addition, although the absolute potency is very similar to that of the best of the benzimidazoles, the ratio of activity against PDE4 to rolipram binding is far more suitable.

The preparation of 8-methoxyquinoline-4-carboxylic acid (3,5-dichloropyridin-4-yl)amide **3c** was achieved via a simple three-step synthesis. Thus commercially available 3-amino-4-methoxybenzoic acid **4** is subjected to the usual Skraup conditions resulting in 8-methoxyquinoline-4-carboxylic acid **5**. This acid is converted to acid chloride **6** using thionyl chloride, which on treatment with the anion of 4-amino-3,5-dichloropyridine (performed using sodium hydride in DMF) resulted in formation of the desired amide **3c** (Scheme 1).

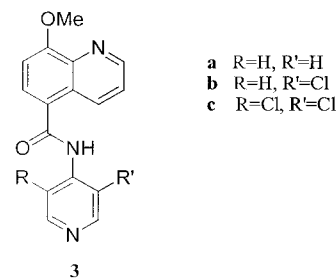
Table 3. Quinolines^a

	PDE4 IC ₅₀ ⁹	RBA IC ₅₀ ¹⁰	PDE4/RBA	PDE3 (%)
3a	1.9	6.3	0.30	NT
3b	0.11	0.48	0.23	NT
3c	0.17	0.53	0.32	10

^aValues are shown as IC₅₀ (μM) or percent inhibition at 20 μM and are the means of at least two experiments. RBA, rolipram binding assay.

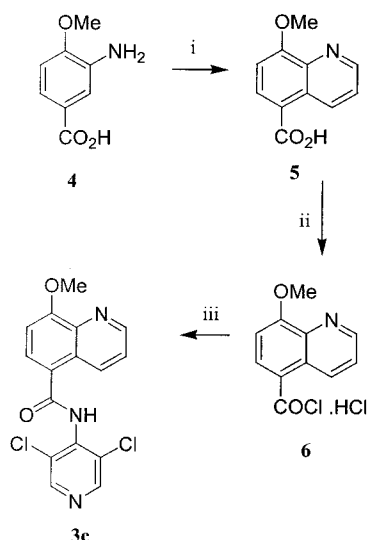

Scheme 1. Reagents and conditions: (i) glycerol, concd H_2SO_4 , I_2 , reflux; (ii) SOCl_2 ; (iii) 4-amino-3,5-dichloropyridine, NaH , DMF.

Given the potency and selectivity achieved, the dichloro-substituted compound **3c** was selected for in vivo studies. Pharmacokinetic studies in the guinea pig dosing at 5 mg/kg po showed a C_{max} of 473 ng/mL and an AUC of 925 ng h/mL. The oral bioavailability was found to be 62% and the iv half-life was 0.6 h.

The compound was then evaluated in a guinea pig lung eosinophilia model.¹⁴ When administered orally at 30 mg/kg, the compound showed significant levels of inhibition of eosinophil influx and hyper-reactivity.

The compound was also assessed for emetic and CNS side effects in a ferret emesis model.¹⁵ Neither emesis nor CNS effects were observed when the compound was dosed orally at 60 mg/kg indicating a significant difference between the efficacious and emetic doses.

In summary, we have identified 8-methoxyquinoline-4-carboxylic acid (3,5-dichloropyridyl-4-yl)amide **3c** as a potent, selective PDE4 inhibitor. The compound has a good pharmacokinetic profile and shows reasonable levels of oral activity in a functional model of inflammation. Compared to some of the early PDE4 inhibitors such as rolipram, it has reduced liability for emetic and CNS side effects. In view of its attractive in vitro and in vivo profiles, the compound was selected for further development and assigned the number **D4418**. Further optimisation work based on this template is described in the following paper.

References and Notes

- (a) Nicolson, C. D.; Shahid, M. *Pulmon. Pharmacol.* **1994**, *7*, 1. (b) Palacios, J. M.; Beleta, J.; Segarra, V. *Il Farmaco* **1995**, *50*, 819.
- (a) Cavalla, D.; Frith, R. *Curr. Med. Chem.* **1995**, *2*, 561. (b) DeBrito, F. B.; Souness, J. E.; Warne, P. J. *Emerg. Drugs* **1997**, *2*, 249.
- Scwabe, U.; Miyake, M.; Ohga, Y.; Daly, J. *Mol. Pharmacol.* **1976**, *12*, 900.
- (a) Muller, T.; Engels, P.; Fozard, J. R. *Trends Pharmacol. Sci.* **1996**, *17*, 294. (b) Kelly, J. J.; Barnes, P. J.; Giembycz, M. A. *Biochem.* **1996**, *318*, 425. (c) Jacobitz, S.; McLaughlin, M. M.; Livi, G. P.; Burman, M.; Torphy, T. J. *Mol. Pharmacol.* **1996**, *50*, 891. (d) Souness, J. E.; Aldous, D.; Sargent, C. *Immunopharmacology* **2000**, *47*, 127.
- Duplantier, A. J.; Biggers, M. S.; Chambers, R. J.; Cheng, J. B.; Cooper, K.; Damon, D. B.; Egger, J. F.; Kraus, K. G.; Marfat, A.; Masamune, H.; Pillar, J. S.; Shirley, J. T.; Umland, J. P.; Watson, J. W. *J. Med. Chem.* **1996**, *39*, 120.
- (a) Giembycz, M. A. *Expert Opin. Invest. Drugs* **2001**, *10*, 1361. (b) Dyke, H. J.; Montana, J. G. *Expert Opin. Invest. Drugs* **2002**, *11*, 1.
- Demoliou-Mason, C. D. *Exp. Opin. Ther. Pat.* **1995**, *5*, 417.
- Buckley, G.; Cooper, N.; Dyke, H. J.; Galleway, F.; Gowers, L.; Gregory, J. C.; Hannah, D. R.; Haughan, A. F.; Hellewell, P. G.; Kendall, H. J.; Lowe, C.; Maxey, R.; Montana, J. G.; Naylor, R.; Picken, C. L.; Runcie, K. A.; Sabin, V.; Tuladhar, B. R.; Warneck, J. B. H. *Bioorg. Med. Chem. Lett.* **2000**, *10*, 2137.
- Thompson, W. J.; Terasaki, W. L.; Epstein, P. M.; Strada, S. J. *Adv. Cyclic Nucleotide Res.* **1979**, *10*, 69.
- Schneider, H. H.; Schmeichen, R.; Brezinski, M.; Seidler, J. *Eur. J. Pharmacol.* **1997**, *127*, 105.
- (a) Teixeira, M. M.; Reyina, S.; Robinson, M.; Shock, A.; Williams, T. J.; Williams, F. M.; Rossi, A. G.; Hellewell, P. G. *Br. J. Pharmacol.* **1994**, *111*, 811. (b) Teixeira, M. M.; Williams, T. J.; Hellewell, P. G. *Br. J. Pharmacol.* **1993**, *110*, 416.
- Buckley, G.; Cooper, N.; Dyke, H. J.; Gilbert, P. J.; Gregory, J. C.; Gowers, L.; Hannah, D. R.; Haughan, A. F.; Kendall, H. J.; Lowe, C.; Montana, J. G.; Picken, C. L.; Sabin, V.; Warneck J. B. H. In: *7-Methoxybenzofuran Oximes as PDE 4 Inhibitors: A Potential Treatment for Asthma. 11th RSC-SCI Medicinal Chemistry Symposium*, Churchill College, Cambridge, UK.
- Buckley, G. M.; Cooper, N.; Davenport, R. J.; Dyke, H. J.; Galleway, F. P.; Gowers, L.; Haughan, A. F.; Kendall, H. J.; Lowe, C.; Montana, J. G.; Oxford, J.; Peake, J. C.; Picken, C. L.; Richard, M. D.; Sabin, V.; Sharpe, A.; Warneck, J. B. H. *Bioorg. Med. Chem. Lett.* **2002**, *12*, 509.
- (a) Mauser, P. J.; Pitman, A.; Witt, A.; Fernandez, X.; Zurcher, J.; Kung, T.; Jones, H.; Watnick, A. S.; Egan, R. W.; Kreutner, W.; Adams III, G. K. *Am. Rev. Respir. Dis.* **1993**, *148*, 1623. (b) Mauser, P. J.; Pitman, A. M.; Fernandez, X.; Foran, S. K.; Adams III, G. K.; Kreutner, W.; Egan, R. W.; Chapman, R. W. *Am. J. Respir. Crit. Care Med.* **1995**, *152*, 467.
- Costall, B.; Domeney, A. M.; Naylor, R. J.; Tattersall, D. *Neuropharmacology* **1987**, *26*, 1321.

ACTIVITY OF D4418, A NOVEL PHOSPHODIESTERASE 4 (PDE4)
INHIBITOR, EFFECTS IN CELLULAR AND ANIMAL MODELS OF
ASTHMA AND EARLY CLINICAL STUDIES.

Montana J, Cooper N, Hunt H, Oxford J, Gristwood R, Lowe C, Kendall H, Buckley G, Maxey R, Warneck J, Gregory J, Gowers L, Galleway F, Naylor R, Tudhalar B, Broadley K, Danahay H. Chiroscience R & D Ltd, Cambridge CB4 4WE, England.

D4418 8-methoxyquinoline-5-[N-(2,5-dichloropyridin-3-yl)]carboxamide) inhibits human PDE4 activity with IC₅₀ 200 nM, but is without activity against other human phosphodiesterases, and does not interact with a wide range of other enzymes and receptors studied. D4418 caused accumulation of intracellular cAMP in leukocytes, *in vitro*, at concentrations achieved after oral dosing in animals. Consistent with its ability to increase intracellular cAMP, D4418 inhibited LPS-induced release of TNF (IC₅₀ 0.16µM) and mitogen induced release of interleukin 5 (IC₅₀ 0.50µM) from peripheral blood mononuclear cells. D4418 is orally active, inhibiting LPS-induced increase in plasma TNF in rats with an ED₅₀ 10mg/kg. Further, D4418 inhibited antigen-induced accumulation of eosinophils into BAL in conscious guinea pigs (40% at 24 hr when administered orally at 10mg/kg at -1hr and +6hr relative to antigen) and provided inhibition of early (40% @ 10mg/kg p.o.) and late phase (100% @ 10mg/kg po) bronchoconstriction in these animals. In addition to anti-inflammatory activity, D4418 also inhibited U46619 induced bronchoconstriction in allergic guinea pigs (100% at 10 mg/kg p.o.). D4418 exhibited an excellent safety profile. At a dose of 60 mg/kg p.o. in ferrets and 60 mg/kg po in dogs, D4418 did not cause retches/vomiting. At doses up to 50mg/kg p.o., D4418 was without effect on gastrointestinal system, weight, food consumption haematological or histological parameters. In Phase I clinical studies, D4418 showed good plasma exposure across a range of doses (e.g. C_{max} 1409ng/ml, AUC 6782 ng.h/ml @ 200mg) and was well tolerated at all doses administered. In summary, D4418 is a potent, selective, orally active PDE4 inhibitor with pronounced anti-inflammatory activity in several cellular and animal models of asthma with an improved side effect profile in animal models and man.

INTRODUCTION

Asthma is a complex disease characterised by reversible airway obstruction, airway inflammation and non-specific airway hyper-reactivity to a variety of environmental and pharmacological challenges. Evidence is now accumulating which implicates airway inflammation as the major underlying pathological process for both the acute and long-term manifestation of asthma involving the release of various mediators from activated inflammatory and immune cells. Prolonged exposure of the airway to these substances produces epithelial damage and smooth muscle hypertrophy. These are morphological changes, which may contribute to the airway hyper-reactivity associated with asthma.

The agents currently available for the treatment of asthma such as β_2 -agonists and steroids are not altogether satisfactory. The β_2 -agonists relieve broncho-constriction through relaxation of airway smooth muscle, but are not thought to treat the underlying disease. The steroidal anti-inflammatory agents can cause sodium and water retention, hypertension, osteoporosis, hyperglycaemia, increased susceptibility to infection, and growth retardation in children.

Recently, cyclic nucleotide phosphodiesterases (PDE's) have received a considerable amount of attention as molecular targets for novel anti-asthma agents. PDE's are involved in the hydrolysis of the active second messengers, the cyclic nucleotides cAMP and cGMP to their 5' inactive forms. The inhibition of the PDE enzymes would, therefore, result in the accumulation of these active molecules. cGMP and cAMP cause a decrease in airway smooth muscle tone, cAMP also decreases inflammatory cell activity.

PDE IV is the predominant PDE isoenzyme in airway smooth muscle and inflammatory cells. From various *in vivo* and *in vitro* studies using animal models the inhibition of this isoenzyme has been shown to have anti-inflammatory effects *via* inhibition of the release of various mediators and of other inflammatory cell activities which play a key role in the asthma disease process. PDE IV inhibitors have been shown to reverse allergen induced bronchoconstriction. Thus, PDE IV inhibitors could offer a new treatment for asthma.

To date the dose limiting side-effects seen for PDE IV inhibitors are nausea and emesis. The research programme at Chiroscience has been directed towards identifying an effective PDE IV inhibitor with reduced nausea and emesis side-effects. This is based on a paradigm in which it is believed selective inhibition of the rolipram low affinity PDE IV form over the rolipram high affinity PDEIV form will lead to a compound with an improved side effect profile. This poster illustrates how this *in vitro* paradigm translates into animal models of airway disease and emesis, and discloses that D4418, a compound identified using this approach, has a good safety profile in man at doses which should provide efficacy based on animal data.

***IN VITRO* PROFILE OF D4418**

D4418 has been evaluated in a number of *in vitro* enzyme assays to look for PDE isoenzyme selectivity. As can be seen from Table I, the compound is a potent, selective PDE IV inhibitor showing greater than 100 fold selectivity for PDE IV over the other PDE isoenzymes. Comparison with the prototypical PDE IV inhibitor, rolipram, also shows a 20 fold increase in PDE IV inhibitory potency over this standard.

The PDE IV isoenzyme has been found to have 2 sites termed high and low affinity rolipram binding sites and these have been characterised using the standard PDE IV inhibitor, rolipram. Rolipram has been found to preferentially select for the high affinity site with an IC_{50} 100 times lower than that found for the low affinity site (Table II). Whilst rolipram shows good efficacy in animal models of lung disease, it has the dose limiting side effects of nausea and emesis in animals and man. A number of other PDE IV inhibitors have also been investigated in efficacy and side effect models, and have been shown to elicit similar effects to rolipram. All of these compounds have a similar *in vitro* profile to rolipram in that they are more potent at the high affinity PDE IV site than the low affinity site. As can be seen from Table II, D4418 is more potent at the low affinity site than the high affinity site and constitutes a 480 increase in selectivity over rolipram. Consequently, this more selective compound provides a significantly reduced emetic profile than rolipram in animal models.

In order to assess the cell penetration of D4418, it was evaluated in a number of cell based assays (Table I). PDE IV inhibitors are known to suppress $TNF\alpha$ release, thus we investigated the effects of D4418 on LPS induced $TNF\alpha$ release from human peripheral blood mononuclear cells (PBMC's). D4418 was a very potent inhibitor of $TNF\alpha$ *in vitro* in this assay showing comparable inhibitory potency to its PDE IV enzyme inhibitor potency. Interleukin 5 (IL5) plays a key role in asthma because of its' importance in eosinophil proliferation, differentiation and activation and we have shown that D4418 also inhibits this cytokine in whole blood, again at concentrations comparable to its enzyme IC_{50} .

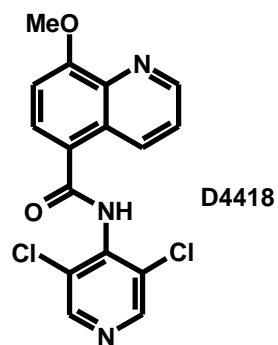

Table I - *In vitro* Profile of D4418

	IC ₅₀ (μM) or % inhibition at 20μM						
	PDE I	PDE II	PDE III	PDE IV	PDE V	TNF#	IL5 ^{''}
D4418	31%	22%	10%	0.17	14%	0.12	0.5
Rolipram	IA	IA	16%	3.6	19%	0.17	1.4

Inhibition of LPS induced TNF release from human PBMC

'' Inhibition of PHA and PMA induced IL5 release whole blood

IA= inactive

Table II – Selectivity for PDE IV High/Low Affinity Sites

	IC ₅₀ (μM)		
	PDE IV	RBA	Ratio
D4418	0.17	0.53	0.3
Rolipram	3.6	0.025	144

RBA= high affinity rolipram binding site

IN VIVO PROFILE OF D4418

Guinea pig models of airway sensitisation are commonly used for the evaluation of potential anti-asthma drugs. In the model outlined here we are able to demonstrate the three pathological features of asthma namely the early phase late phase bronchoconstriction, inflammatory cell infiltration and airway hyper-reactivity. The model involves using ovalbumin sensitised guinea pigs which are challenged with aerosol ovalbumin under mepyramine maleate protection. Airway function (represented as airway resistance, negative values denoting bronchoconstriction) is measured in conscious animals for 24 hours after challenge. At 24 hours hyper-reactivity to a low dose thromboxane mimetic challenge (U46619) is measured. This low dose of U46619 will only result in bronchoconstriction in sensitised animals and the response is defined as 'hyper-reactivity'. The animals are then sacrificed and bronchoalveolar lavage carried out to measure cell infiltration. The effect of D4418, (10mg/kg, p.o.) in this model is illustrated in the figures below.

D4418 elicits a significant inhibition of the early phase response in this model (ca 45%) and completely abolishes the late phase response (Figure I). A concomitant inhibition of cell influx into the lung is also observed (ca 40% inhibition of the infiltration of macrophages, eosinophils and neutrophils). Similarly, the U46619 induced hyperreactivity is completely inhibited by D4418.

Figure I - Inhibition of Antigen Induced Bronchoconstriction in the Guinea pig by D4418 at 10mg/kg, po.

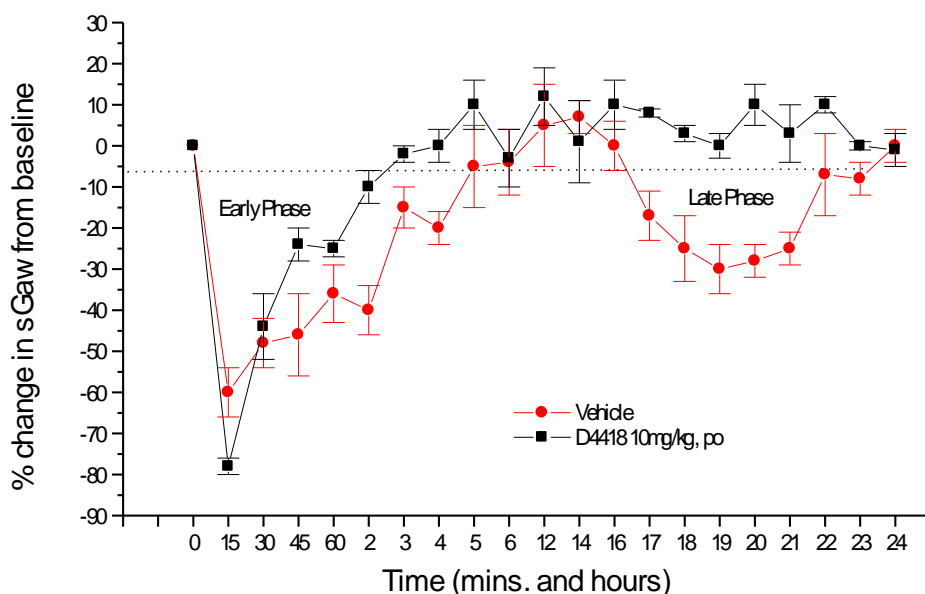

sGaw = specific airway conductance, negative values represent bronchoconstriction.

Effect of D4418, on Bronchoalveolar Cell Infiltration in the Guinea pig at 10mg/kg, po

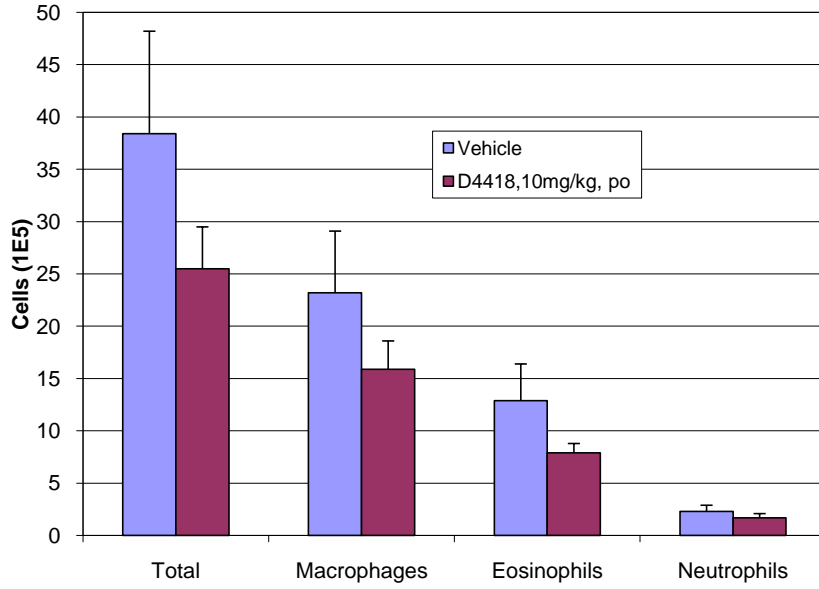

Airway Response to Inhaled U46619 24hrs After OVA Challenge

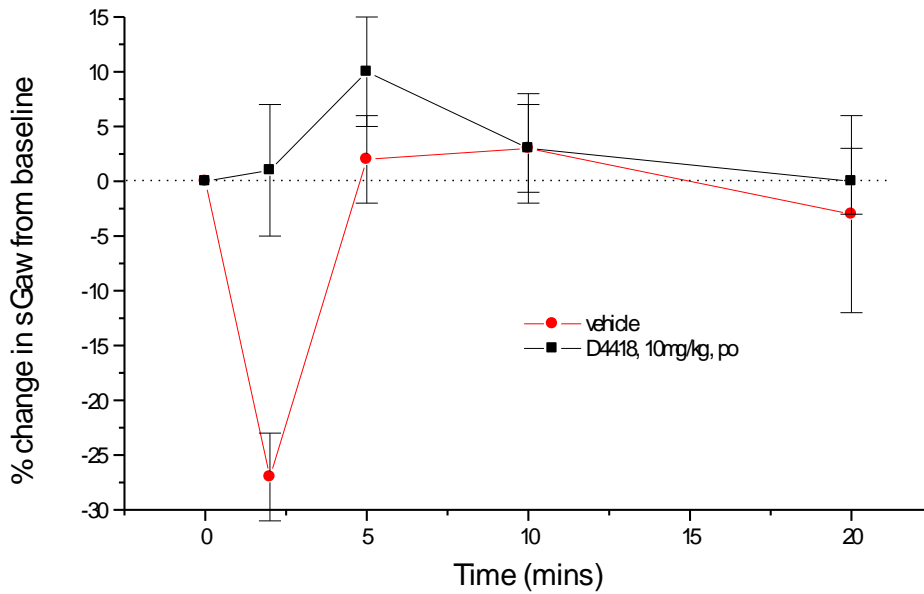

100% inhibition of the airway hyper-reactivity is observed.

To ensure that the effect observed in the guinea pig is due to D4418, the pharmacokinetic profile of the compound was determined. The compound was well absorbed after oral dosing, showing a good plasma half life and plasma levels well in excess of the enzyme inhibitory concentrations up to 4h post dosing. As can be seen from Figure II, D4418 has a bioavailability of 69%.

FIGURE II – PLASMA CONCENTRATIONS OF D4418 IN THE GUINEA PIG AFTER IV/PO DOSING

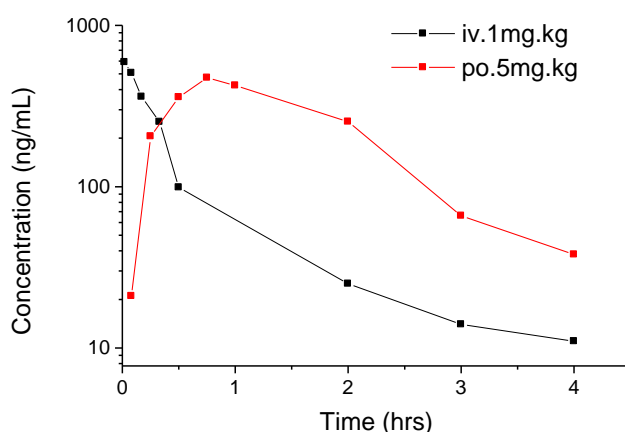

The classic side effects of existing PDE IV inhibitors are nausea and emesis. At doses below those required for emesis animals will manifest a pattern of behavioural changes characteristic of nausea. The ferret is the species most commonly used to model emesis, a range of emetic drugs spanning a wide range of mechanisms have been evaluated in this model at is generally considered that this species is similar to man. In this model the nausea side effects observed are commonly head burrowing, salivation and mouth scratching.

D4418 has been administered to ferrets at doses up to 100mg/kg, p.o. No emesis was observed at any dose nor any of the nausea related behavioural changes. However, at the very high dose of 100mg/kg, p.o., retching was observed in one of four animals. Rolipram causes the behavioural effects, retching, and vomiting in ferrets at 0.3mg/kg p.o., thus illustrating that D4418 has a significantly improved side effect profile. This can be seen more clearly by comparing the dose of each compound required for efficacy and that showing the nausea/emesis side effects (Table III).

TABLE III – THERAPEUTIC INDEX IN ANIMAL STUDIES

	Efficacy* (mg/kg po)	Emesis# (mg/kg po)	Ratio
D4418	10	100	0.1
Rolipram	10	0.3	30

* Efficacious dose in guinea pig eosinophilia model

Incidence of Retching and Vomiting in the Ferret for Oral Dosing of Rolipram and D4418

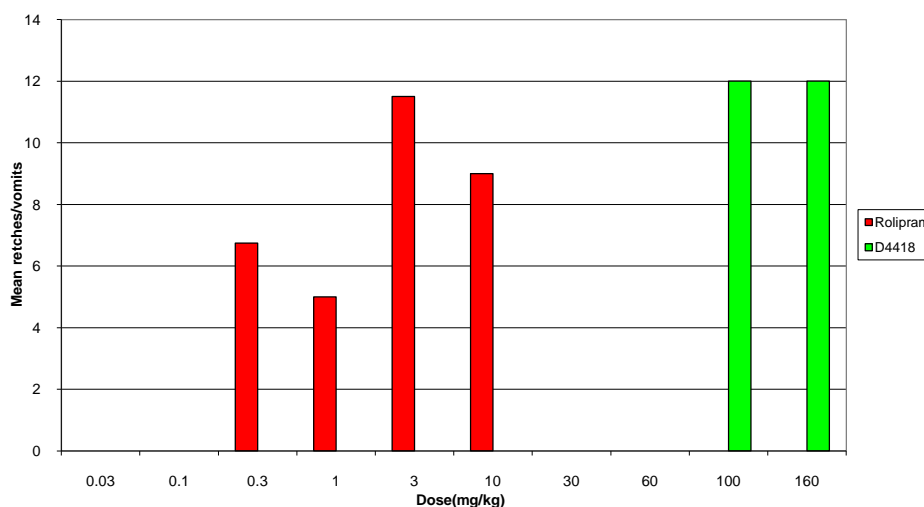

Behavioural/emesis effects in the ferret

TOXICOLOGY AND CLINICAL PROFILE

A series of preclinical safety studies were performed to support the Phase 1 evaluation of D4418. This included *in vitro* genetic toxicology studies (Ames and chromosome aberration studies), and escalating single and multiple dose oral toxicological evaluation in rats and dogs. These studies showed that there was no significant toxicological findings in either species at plasma concentrations that were significantly higher than that required to see efficacy in animal models.

In the Phase I clinical study an escalating single dose, randomised, placebo controlled protocol was employed ranging from 5mg to 200mg. The aim of the study was to assess safety, tolerability and pharmacokinetics in healthy volunteers. The results of the study showed that D4418 provided a good half-life and plasma exposure in man (Figure III), and that even at the highest dose, the compound did not show any signs of emesis. The side effects observed (headache, dizziness, nausea) were mild and occurred in the higher dose groups (Table IV).

TABLE IV – ADVERSE EVENTS OBSERVED

- Mild nausea (5 cases) seen at higher doses - no effect on daily activity - no treatment required.
- Mild dizziness (8 cases) seen at higher doses - no effect on daily activity - no treatment required.

**Plasma Concentrations in Healthy Male Subjects
(n=5) following 200mg D4418 po**

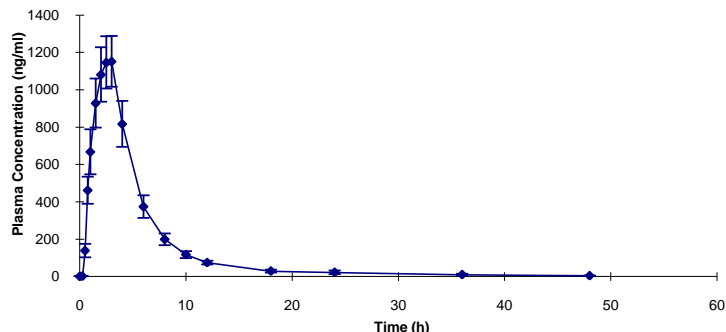

SUMMARY

D4418 from its *in vitro* profile is a selective PDE IV inhibitor.

In a guinea pig model of asthma, D4418 has been shown to inhibit the pathological features of this disease at an oral dose of 10 mg/kg. This coupled with its' lack of emesis in the ferret, when dosed orally at up to 60mg/kg, shows it to have an excellent therapeutic window.

D4418 selects for the low affinity catalytic site of the PDE IV isoenzyme over the high affinity site, which appears to confirm the hypothesis that this type of selectivity is indicative of less emetic PDE IV inhibitors.

Following oral administration to the rat and dog, D4418 is well absorbed, the maximum plasma concentration generally being observed within 2 hours of dosing. In the rat, urine was the main route of excretion. The majority of the dose was eliminated within 24 hours of dosing.

In single and repeated dose toxicity studies, in rats and dogs, D4418 was well tolerated and produced no evidence of specific or target organ toxicity at plasma concentrations significantly in excess of those predicted in the clinical situation.

In a phase I clinical study in healthy volunteers, D4418 showed good plasma exposure across a range of doses, with no significant side effects even at the highest dose tested. This illustrates that the paradigm established in *in vitro* assays, not only translates into relevant animal models of disease and side effects, but also into man.



Pergamon

Bioorganic & Medicinal Chemistry Letters 12 (2002) 1617–1619

BIOORGANIC &
MEDICINAL
CHEMISTRY
LETTERS

8-Methoxyquinolines as PDE4 Inhibitors

Motasim Billah,^c George M. Buckley,^a Nicola Cooper,^a Hazel J. Dyke,^a Robert Egan,^c
Ashit Ganguly,^c Lewis Gowers,^a Alan F. Haughan,^a Hannah J. Kendall,^a
Christopher Lowe,^a Michael Minnicozzi,^c John G. Montana,^a Janet Oxford,^a
Joanna C. Peake,^a C. Louise Picken,^a John J. Piwinski,^c Robert Naylor,^b
Verity Sabin,^{a,*} Neng-Yang Shih^c and Julie B. H. Warneck^a

^aCelltech Group plc, Granta Park, Abingdon, Cambridge CB1 6GS, UK

^bDept. of Pharmacology, University of Bradford, Bradford BD7 1DP, UK

^cSchering-Plough Corporation, Galloping Hill Road, Kenilworth, NJ 07033-0530, USA

Received 8 March 2002; accepted 4 April 2002

Abstract—The synthesis and pharmacological profile of a novel series of 2-substituted 8-methoxyquinolines is described. The 2-trifluoromethyl compound was found to be a potent inhibitor of phosphodiesterase type 4 (PDE4). © 2002 Elsevier Science Ltd. All rights reserved.

Inhibitors of PDE4 (a cAMP specific phosphodiesterase found in inflammatory cells and airway smooth muscle) have been investigated extensively as a potential treatment for asthma.¹ We have previously reported novel methoxybenzo-fused heterocycles (such as 7-methoxybenzofurans,² 7-methoxybenzimidazoles,³ 8-methoxyquinolines³ and 7-methoxyfuro-[2,3-*c*]-pyridines⁴) as PDE4 inhibitors. The most efficacious of these compounds in vivo was the 8-methoxyquinoline **D4418**.³ Because the in vitro and in vivo profiles of **D4418** were so promising, we next prepared a series of 8-methoxyquinoline-5-carboxamides with a variety of substituents at the 2-position. Our objective was to improve in vitro potency, in vivo efficacy and plasma exposure and half life.

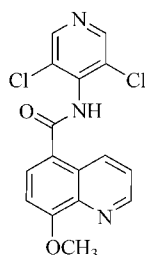

D4418

The 8-methoxyquinolines **2a** and **2b** were prepared by methylation of commercially available 8-hydroxyquinolines (Scheme 1).

2c was prepared by Skraup quinoline synthesis starting with 2-methoxyaniline (Scheme 2).

o-Anisidine was reacted with ethyl 1,1,1-trifluoroacetate in the presence of polyphosphoric acid to give a quinolone which was chlorinated at the 4-position with phosphorous pentachloride in phosphorous oxychloride. The 4-chloro substituent was removed by hydrogenation to give **2d** (Scheme 3).

2e was prepared from **2a** using butyllithium followed by iodomethane (Scheme 4).

The 8-methoxyquinolines **2a–2e** were brominated *para* to the methoxy group and then carbonylated to give 8-methoxyquinoline-5-carboxylic acids **3a–3e** (Scheme 5).

3a–3e were activated as acid chlorides or *p*-nitrophenyl esters and then reacted with the sodium salt of 4-amino-3,5-dichloropyridine to give the 8-methoxyquinoline-5-carboxamides **4a–4e** (Scheme 6).

4b was reacted with methylmagnesium bromide to give the 2-acetyl compound **4f** which was itself reacted with sodium borohydride to give **4g** and with *O*-methylhydroxylamine to give **4h** (Scheme 7).

*Corresponding author. Tel.: +44-1223-896513; fax: +44-1223-896400; e-mail: verity.sabin@celltechgroup.com

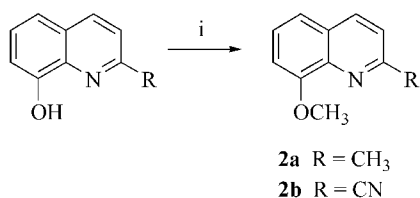

Scheme 1. Reagents and conditions: (i) MeI, NaOH, TBAI, THF, H₂O.

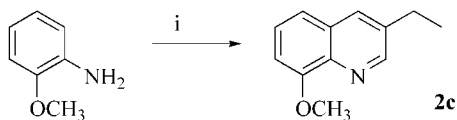

Scheme 2. Reagents and conditions: (i) H₂SO₄, I₂, 2-ethyl acrolein.

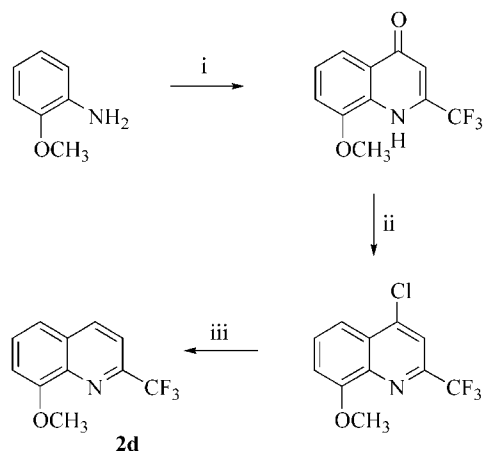

Scheme 3. Reagents and conditions: (i) EtO₂CCH₂COCF₃, PPA; (ii) PCl₅, POCl₃; (iii) H₂, Pd/C.

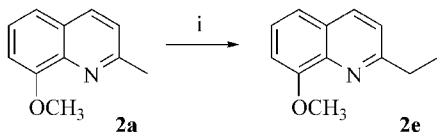

Scheme 4. Reagents and conditions: (i) BuLi, THF then MeI.

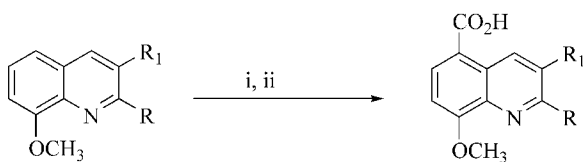

Scheme 5. Reagents and conditions: (i) Br₂, MeOH; (ii) CO, PdCl₂(PPh₃)₂, Et₃N, THF or DMF, H₂O.

The 8-methoxyquinoline-5-carboxamides **4a–4h** were screened *in vitro* against PDE4 and PDE3, and in a rolipram binding assay (RBA) (Table 1).

4a was 2-fold more potent against PDE4 than **D4418**. Incorporating nitrile at the 2-position (**4b**) not only decreased activity against PDE4 but also increased activity at the rolipram binding site, leading to a very

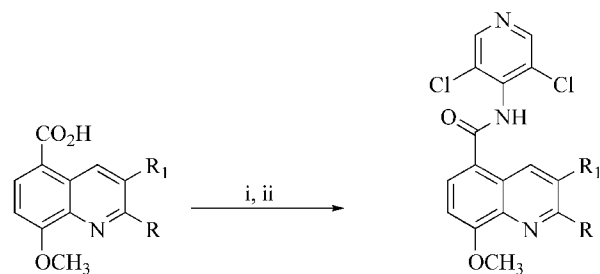

Scheme 6. Reagents and conditions: (i) C₂Cl₂O₂, DMF, DCM or *p*-nitrophenol, Et₃N, DMAP, DCM; (ii) sodium salt of 4-amino-3,5-dichloropyridine, DMF.

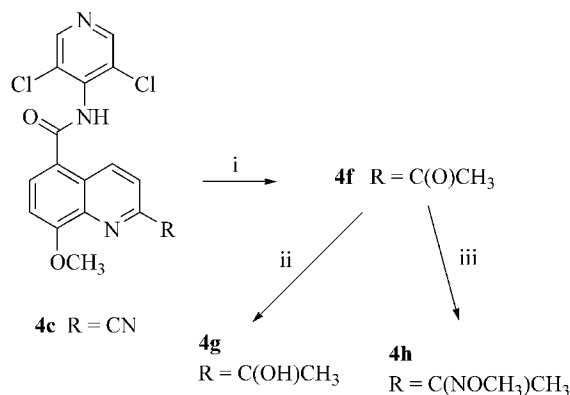

Scheme 7. Reagents and conditions: (i) MeMgBr, THF; (ii) NaBH₄, EtOH; (iii) MeONH₂, pyridine, toluene.

poor ratio. However, replacing the methyl group of **4a** with trifluoromethyl (**4d**) improved activity against PDE4. Of the two ethyl compounds **4c** and **4e**, the 2-isomer **4e** was significantly more potent and had a better ratio than the 3-isomer **4c**. The 2-acetyl compound **4f** was less potent against PDE4 than **D4418**, and had a similar ratio. Reduction of the acetyl group in **4f** to give the alcohol **4g** improved activity against PDE4 and maintained the ratio, while converting **4f** to the methoxy oxime **4h** improved activity against both PDE4 and in the RBA and was therefore detrimental to the ratio.

On the basis of its potency against PDE4 and selectivity for the catalytic site over the rolipram binding site, **4d** was selected for evaluation in guinea pig pharmacokinetic studies⁷ and in a guinea pig lung eosinophilia study.⁸ Pharmacokinetic studies in the guinea pig (Fig. 1), dosing orally at 5 mg/kg, showed **4d** to have a C_{max} of 380 ng/mL, an AUC of 1174 ng h/mL and an oral bioavailability of 78%.

In a guinea pig lung eosinophilia model, **4d** caused significant levels of inhibition of eosinophil influx when administered orally at 10 and 3 mg/kg (Fig. 2).

4d was assessed for emetic side effects in a ferret emesis model.⁹ No emesis was observed when the compound was dosed orally at 6 mg/kg to a group of four animals.

Table 1. 2-Substituted quinoline-5-carboxamides^a

	R	R ₁	PDE4 IC ₅₀ ⁵	RBA IC ₅₀ ⁶	PDE 4:RBA	PDE 3 (%)
D4418	H	H	0.17	0.53	0.32	10
4a	CH ₃	H	0.088	0.074	1.19	21
4b	CN	H	0.70	0.043	16.28	38
4c	H	CH ₂ CH ₃	0.21	0.16	1.31	12
4d	CF ₃	H	0.051	0.077	0.66	15
4e	CH ₂ CH ₃	H	0.043	0.0753	0.57	35
4f	C(O)CH ₃	H	0.44	1.5	0.29	27
4g	C(OH)CH ₃	H	0.18	0.79	0.22	30
4h	C(NOCH ₃)CH ₃	H	0.21	0.14	1.5	22

^aValues are shown as IC₅₀ (μM) or per cent inhibition at 20 μM and are the means of at least two experiments. RBA, rolipram binding assay. PDE4 was obtained from human U937 cells, rolipram binding protein was obtained from rat brain tissues, and PDE3 was obtained from human platelets.

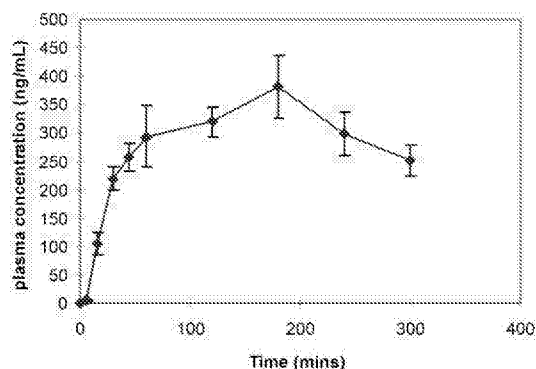

Figure 1. PK profile of **4d** in guinea pig dosing orally at 5 mg/kg ($n=4$).

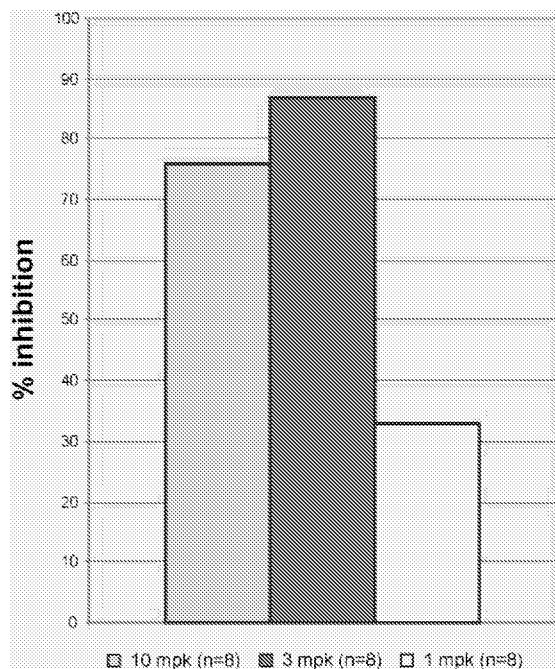

Figure 2. Inhibition of guinea pig lung eosinophilia by oral dosing of **4d** at 1, 3 and 10 mg/kg.

In conclusion, **4d** is a novel, potent and selective inhibitor of PDE4. Compared with **D4418**, it had an improved plasma half life in vivo when dosed orally to guinea pigs, and significantly improved activity in a guinea pig lung eosinophilia model. Further studies on compounds in this series will be reported in due course.

References and Notes

- (a) Karlsson, J.-A.; Aldous, D. *Exp. Opin. Ther. Pat.* **1997**, *7*, 989. (b) Dyke, H. D.; Montana, J. G. *Exp. Opin. Invest. Drugs* **1999**, *8*, 1301.
- Buckley, G. M.; Cooper, N.; Dyke, H. J.; Galleway, F.; Gowers, L.; Gregory, J. C.; Hannah, D. R.; Haughan, A. F.; Hellewell, P. G.; Kendall, H. J.; Lowe, C.; Maxey, R.; Montana, J. G.; Naylor, R.; Picken, C. L.; Runcie, K. A.; Sabin, V.; Tuladhar, B. R.; Warneck, J. B. H. *Bioorg. Med. Chem. Lett.* **2000**, *10*, 2137.
- Buckley, G. M.; Cooper, N.; Dyke, H. J.; Galleway, F.; Gowers, L.; Haughan, A. F.; Kendall, H. J.; Lowe, C.; Maxey, R.; Montana, J. G.; Naylor, R.; Oxford, J.; Peake, J. C.; Picken, C. L.; Runcie, K. A.; Sabin, V.; Sharpe, A.; Warneck, J. B. H. *Bioorg. Med. Chem. Lett.* **2002**, *12*, 1613.
- Buckley, G. M.; Cooper, N.; Davenport, R. J.; Dyke, H. J.; Galleway, F. P.; Gowers, L.; Haughan, A. F.; Kendall, H. J.; Lowe, C.; Montana, J. G.; Oxford, J.; Peake, J. C.; Picken, C. L.; Richard, M. D.; Sabin, V.; Sharpe, A.; Warneck, J. B. H. *Bioorg. Med. Chem. Lett.* **2002**, *12*, 509.
- Thompson, W. J.; Terasaki, W. L.; Epstein, P. M.; Strada, S. J. *Adv. Cyclic Nucleotide Res.* **1979**, *10*, 69.
- Schneider, H. H.; Schmeichen, R.; Brezinski, M.; Seidler, J. *Eur. J. Pharmacol.* **1997**, *127*, 105.
- The pharmacokinetic profiles of the selected compounds were determined in animals cannulated in the right carotid artery for blood collection. For oral dosing, the compound was prepared in 0.4% w/v methylcellulose in water. Samples were collected at 0.5, 1, 2, 4, 6, 8 and 12 h post-dosing. Plasma was obtained by centrifugation of the blood sample and the drug concentration was then determined using liquid chromatography-mass spectrometry following protein precipitation.
- (a) Mauser, P. J.; Pitman, A.; Witt, A.; Fernandez, X.; Zurcher, J.; Kung, T.; Jones, H.; Watnick, A. S.; Egan, R. W.; Kreutner, W.; Adams, G. K. III *Am. Rev. Respir. Dis.* **1993**, *148*, 1623. (b) Mauser, P. J.; Pitman, A. M.; Fernandez, X.; Foran, S. K.; Adams, G. K. III; Kreutner, W.; Egan, R. W.; Chapman, R. W. *Am. J. Respir. Crit. Care Med.* **1995**, *152*, 467.
- Costall, B.; Domeney, A. M.; Naylor, R. J.; Tattersall, F. D. *Neuropharmacology* **1987**, *26*, 1321.



Pergamon

Bioorganic & Medicinal Chemistry Letters 12 (2002) 1621–1623

BIOORGANIC &
MEDICINAL
CHEMISTRY
LETTERS

Synthesis and Profile of SCH351591, a Novel PDE4 Inhibitor

Motasim Billah,^c Nicola Cooper,^a Francis Cuss,^c Richard J. Davenport,^a Hazel J. Dyke,^a Robert Egan,^c Ashit Ganguly,^c Lewis Gowers,^a Duncan R. Hannah,^a Alan F. Haughan,^a Hannah J. Kendall,^a Christopher Lowe,^a Michael Minnicozzi,^c John G. Montana,^a Robert Naylor,^b Janet Oxford,^a Joanna C. Peake,^a John J. Piwinski,^c Karen A. Runcie,^a Verity Sabin,^{a,*} Andrew Sharpe,^a Neng-Yang Shih^c and Julie B. H. Warneck^a

^aCelltech Group plc, Granta Park, Abington, Cambridge CB1 6GS, UK

^bDepartment of Pharmacology, University of Bradford, Bradford BD7 1DP, UK

^cSchering-Plough Corporation, Galloping Hill Road, Kenilworth, NJ 07033-0530, USA

Received 8 March 2002; accepted 4 April 2002

Abstract—The syntheses and pharmacological profiles of some 2-trifluoromethyl-8-methoxyquinoline-5-carboxamides are described. **SCH351591** is a potent selective inhibitor of phosphodiesterase type 4 (PDE4). © 2002 Elsevier Science Ltd. All rights reserved.

PDE4 inhibitors are a class of compounds that have been extensively investigated as a treatment for asthma and other inflammatory disorders.¹ We have recently reported a novel series of 8-methoxyquinoline-5-carboxamide PDE4 inhibitors which had good selectivity for PDE4 and an acceptable therapeutic ratio for binding at the catalytic site over the rolipram binding site.² Of this series, one of the most potent compounds in vitro was the 2-trifluoromethyl quinoline **SCH365351**. **SCH365351** was active in a guinea pig lung eosinophilia model³ when dosed at 10 and 3 mpk and also had good plasma exposure in guinea pigs.

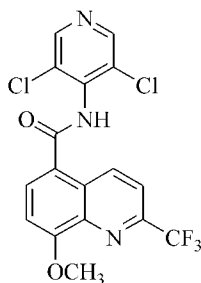

SCH365351

However, a major metabolite was observed in a rat PK study on **SCH365351** (Fig. 1). At time points > 3 h, the

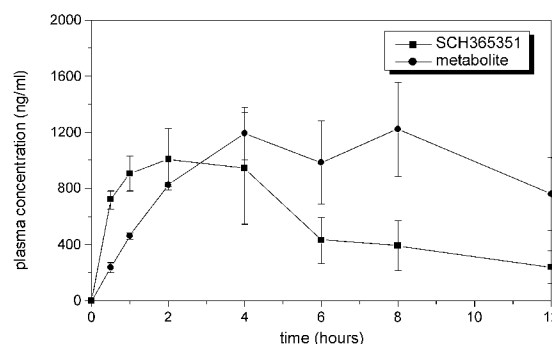

Figure 1. PK profile of **SCH365351** and the major metabolite in rats.

levels of metabolite were higher than those of the parent compound.

The metabolite was identified as the pyridine *N*-oxide, a discovery which prompted us to investigate the profile of this compound and the SAR around other pyridine *N*-oxides of that type.

SCH365351 was dissolved in chloroform and treated with peracetic acid to give the *N*-oxide **3a** (Scheme 1).

8-Methoxy-2-trifluoromethylquinoline-5-carboxylic acid was activated by conversion either to the acid chloride or to the *p*-nitrophenyl ester and then reacted with the

*Corresponding author. Tel.: +44-1223-896513; fax: +44-1223-896400; e-mail: verity.sabin@celltechgroup.com

sodium salts of various substituted 4-amino pyridines to give amides such as **2b–2d** (Scheme 2).

These were oxidised to the *N*-oxides **3b–3d** using peracetic acid as described above. **2b–2d** and **3a–3d** were screened in vitro against PDE4 and in a rolipram binding assay (RBA) (Table 1).

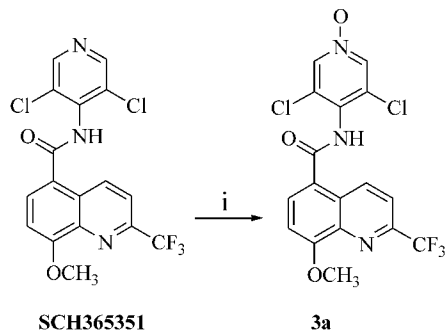

Scheme 1. Reagents and conditions: (i) peracetic acid (36–40% in acetic acid), 50°C, 7 days, CHCl₃.

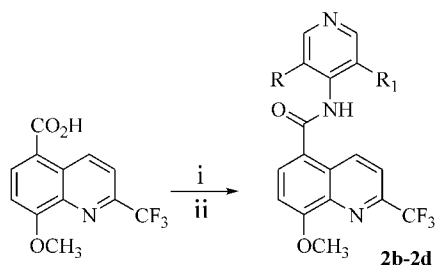

Scheme 2. Reagents and conditions: (i) C₂Cl₂O₂, DMF, DCM or *p*-nitrophenol, Et₃N, DMAP, DCM; (ii) sodium salt of appropriate amino pyridine, DMF.

Table 1. 2-Trifluoromethylquinoline-5-carboxamides^a

	R	R ₁	PDE4 IC ₅₀ ⁴	RBA IC ₅₀ ⁵	PDE4:RBA
SCH365351	Cl	Cl	0.051	0.077	0.66
2b	Cl	H	1.12	0.11	10
2c	Me	Me	0.12	0.058	2.1
2d	F	F	0.035	0.038	0.94
3a (SCH351591)	Cl	Cl	0.06	0.15	0.40
3b	Cl	H	0.24	0.37	0.65
3c	Me	Me	0.15	0.38	0.39
3d	F	F	0.07	0.06	1.17

^aValues are shown as IC₅₀ (μM) and are the means of at least two experiments. RBA, rolipram binding assay. PDE4 was obtained from human U937 cells and rolipram binding protein was obtained from rat brain tissues.

Table 2. In vitro profile of SCH351591^a

PDE4	0.06
PDE1	15%
PDE2	0%
PDE3	31%
PDE5	5%
PDE7	10%

^aValues are shown as IC₅₀ (μM) or percent inhibition at 10 μM and are the means of at least two experiments. PDE1 was recombinant enzyme, PDE2, 3 and 5 were obtained from human platelets, PDE7 was obtained from a human T-lymphocyte cell line.

The activities of the *N*-oxides **3a–3d** against PDE4 were similar to or improved over those of the parent pyridines SCH365351 and **2b–2d**. The PDE4:RBA ratios were improved except in the case of **3d**. Both the monochloro and dimethyl compounds **3b** and **3c** were significantly less active against PDE4 than **3a**; the difluoro compound **3d**, though of similar activity to **3a** against PDE4, had a much poorer ratio. The dichloropyridine-*N*-oxide **3a** was therefore selected for further studies and given the number SCH351591.

SCH351591 was screened against other PDE isozymes and was found to be selective for PDE4 over PDE1, 2, 3, 5 and 7 (Table 2).

Pharmacokinetic studies⁶ in the rat (Fig. 2), dosing orally at 3 mg/kg, showed SCH351591 to have a C_{max} of 3058 ng/mL and an AUC_{0-t} of 50503 ng h/mL, a considerable improvement over SCH365351 (C_{max} = 1008 ng/mL, AUC_{0-t} = 6860 ng h/mL).

The guinea pig PK profile (Fig. 3), was also greatly improved over SCH365351. (C_{max} of 1393 ng/mL and an AUC_{0-t} of 15757 ng h/mL when dosed orally at 3 mg/kg compared with C_{max} = 380 ng/mL and AUC_{0-t} = 1174 ng h/mL for SCH365351.)

When administered orally in a guinea pig lung eosinophilia model,⁷ SCH351591 caused significant levels of inhibition of eosinophil influx at 10, 3 and 1 mg/kg (Fig. 4).

SCH351591 was assessed for emetic side effects in a ferret emesis model.⁸ No emesis was observed when the

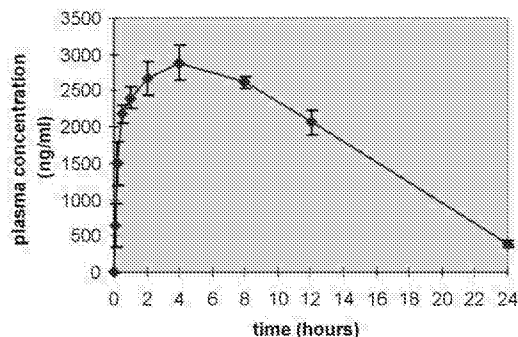

Figure 2. PK profile of SCH351591 in rats dosed orally at 3 mg/kg (*n* = 3).

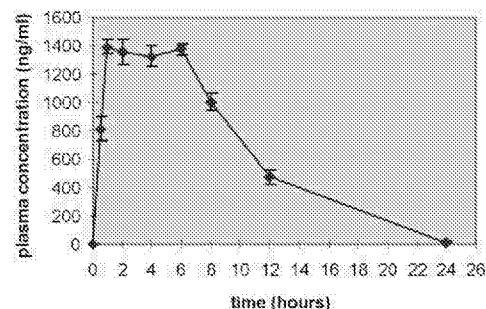

Figure 3. PK profile of SCH351591 in guinea pigs dosed orally at 3 mg/kg (*n* = 3).

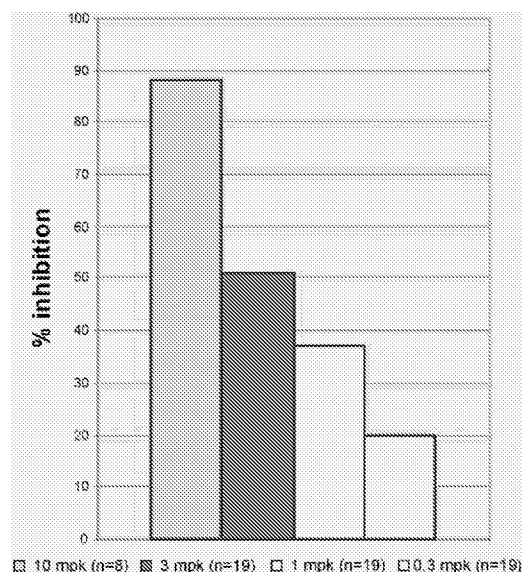

Figure 4. Inhibition of guinea pig lung eosinophilia by oral dosing of SCH351591.

compound was dosed orally to a group of four animals at 5 mg/kg each, despite appreciable plasma levels ($C_{max} = 3500$ ng/mL, $AUC_{0-t} = 26700$ ng h/mL) at this dose.

In summary, SCH351591 is a potent selective inhibitor of PDE4 with an excellent PK profile and significant activity in an in vivo model at doses which showed no emetic side effects. It was therefore selected for further studies, and details on the outcome of these will be disclosed in subsequent publications.

References and Notes

- (a) Karlsson, J.-A.; Aldous, D. *Exp. Opin. Ther. Pat.* **1997**, *7*, 989. (b) Dyke, H. D.; Montana, J. G. *Exp. Opin. Invest. Drugs* **1999**, *8*, 1301.
- Billah, M.; Buckley, G. M.; Cooper, N.; Dyke, H. J.; Egan, R.; Ganguly, A.; Gowers, L.; Haughan, A. F.; Kendall, H. J.; Lowe, C.; Minnicozzi, M.; Montana, J. G.; Oxford, J.; Peake, J. C.; Picken, C. L.; Piwinski, J. J.; Naylor, R.; Sabin, V.; Shih, N.-Y.; and Warneck, J. B. H., *Bioorg. Med. Chem Lett.* **2002**, *12*, 1617.
- (a) Mauser, P. J.; Pitman, A.; Witt, A.; Fernandez, X.; Zurcher, J.; Kung, T.; Jones, H.; Watnick, A. S.; Egan, R. W.; Kreutner, W.; Adams, G. K., III *Am. Rev. Respir. Dis.* **1993**, *148*, 1623. (b) Mauser, P. J.; Pitman, A. M.; Fernandez, X.; Foran, S. K.; Adams, G. K., III; Kreutner, W.; Egan, R. W.; Chapman, R. W. *Am. J. Respir. Crit. Care Med.* **1995**, *152*, 467.
- Thompson, W. J.; Terasaki, W. L.; Epstein, P. M.; Strada, S. J. *Adv. Cyclic Nucleotide Res.* **1979**, *10*, 69.
- Schneider, H. H.; Schmeichen, R.; Brezinski, M.; Seidler, J. *Eur. J. Pharmacol.* **1997**, *127*, 105.
- The pharmacokinetic profiles of the selected compounds were determined in animals cannulated in the right carotid artery for blood collection. For oral dosing, the compound was prepared in 0.4% w/v methylcellulose in water. Samples were collected at 0.5, 1, 2, 4, 6, 8 and 12 h post-dosing. Plasma was obtained by centrifugation of the blood sample and the drug concentration was then determined using liquid chromatography–mass spectrometry following protein precipitation.
- (a) Mauser, P. J.; Pitman, A.; Witt, A.; Fernandez, X.; Zurcher, J.; Kung, T.; Jones, H.; Watnick, A. S.; Egan, R. W.; Kreutner, W.; Adams, G. K., III *Am. Rev. Respir. Dis.* **1993**, *148*, 1623. (b) Mauser, P. J.; Pitman, A. M.; Fernandez, X.; Foran, S. K.; Adams, G. K., III; Kreutner, W.; Egan, R. W.; Chapman, R. W. *Am. J. Respir. Crit. Care Med.* **1995**, *152*, 467.
- Costall, B.; Domeney, A. M.; Naylor, R. J.; Tattersall, F. D. *Neuropharmacology* **1987**, *26*, 1321.

Pharmacology of *N*-(3,5-Dichloro-1-oxido-4-pyridinyl)-8-methoxy-2-(trifluoromethyl)-5-quinoline Carboxamide (SCH 351591), a Novel, Orally Active Phosphodiesterase 4 Inhibitor

M. MOTASIM BILLAH, NICOLA COOPER, MICHAEL MINNICOZZI, JULIE WARNECK, PENG WANG, JOHN A. HEY, WILLIAM KREUTNER, CHARLES A. RIZZO, SIDNEY R. SMITH, SIMON YOUNG, RICHARD W. CHAPMAN, HAZEL DYKE, NANG-YANG SHIH, JOHN J. PIWINSKI, FRANCIS M. CUSS, JOHN MONTANA, ASHIT K. GANGULY, and ROBERT W. EGAN

Schering-Plough Research Institute, Kenilworth, New Jersey (M.M.B., M.M., P.W., J.A.H., W.K., C.A.R., S.R.S., S.Y., R.W.C., N.Y.S., J.J.P., F.M.C., A.K.G., R.W.E.); and Celltech Chiroscience Ltd., Cambridge, United Kingdom (N.C., J.W., H.D., J.M.)

Received December 14, 2001; accepted March 19, 2002 This article is available online at <http://jpet.aspetjournals.org>

ABSTRACT

N-(3,5-Dichloro-1-oxido-4-pyridinyl)-8-methoxy-2-(trifluoromethyl)-5-quinoline carboxamide (SCH 351591) has been identified as a potent ($IC_{50} = 58$ nM) and highly selective type 4 phosphodiesterase (PDE4) inhibitor with oral bioactivity in several animal models of lung inflammation. *N*-(3,5-Dichloro-4-pyridinyl)-8-methoxy-2-(trifluoromethyl)-5-quinoline carboxamide (SCH 365351), the only significant in vivo metabolite, is also a potent and highly selective PDE4 inhibitor ($IC_{50} = 20$ nM). Both SCH 351591 and SCH 365351 inhibited cytokine production in human blood mononuclear cell preparations. Oral SCH 351591 significantly attenuated allergen-induced eosinophilia and airway hyperreactivity in allergic guinea pigs at doses as low as 1 mg/kg. In this model, oral SCH 365351 showed similar potency. When SCH 351591 was administered orally to allergic cynomolgus monkeys at 3 mg/kg, *Ascaris suum*-induced lung eosinophilia was blocked. Hyperventilation-

induced bronchospasm in nonallergic guinea pigs, a model for exercise-induced asthma, was also suppressed significantly by oral SCH 351591 at 0.3 mg/kg. Cilomilast (SB 207499; Ariflo), a PDE4 inhibitor currently being developed for asthma and chronic obstructive pulmonary disease (COPD), was 10- to 30-fold less potent than SCH 351591 at inhibiting guinea pig lung eosinophilia and hyperventilation-induced bronchospasm. In a ferret model of emesis, maximum nonemetic oral doses of SCH 351591 and cilomilast were 5 and 1 mg/kg, respectively. Comparison of plasma levels at these nonemetic doses in ferrets to those at doses inhibiting hyperventilation-induced bronchospasm in guinea pigs gave a therapeutic ratio of 16 for SCH 351591 and 4 for cilomilast. Thus, SCH 351591 exhibits a promising preclinical profile as a treatment for asthma and COPD.

Asthma is a complex multifactorial disease characterized by reversible airway obstruction, airway inflammation, and nonspecific airway hyperreactivity (Mayer and Wills-Karp, 1999; Bertrand, 2000). Chronic obstructive pulmonary diseases (COPDs), on the other hand, are characterized by mostly irreversible airway obstruction due to chronic bronchitis and emphysema (Hay, 2000). Inflammation of the airways is believed to be central to the airways dysfunction in asthma and COPD (O'Shaughnessy et al., 1997; Roche, 1998). In these conditions, the airway wall is infiltrated by a variety of inflammatory cells, including

mast cells, macrophages, T lymphocytes, eosinophils, and neutrophils. These cells release a host of mediators, including cytokines, chemokines, and bronchospastic agents that act in concert with neurotransmitters such as acetylcholine and neurokinins from pulmonary nerves to produce bronchospasm, pulmonary edema, mucus hypersecretion, and other features of asthma and COPD. Eosinophilia is the dominant feature of lung inflammation in asthma, whereas COPD is marked by an intense pulmonary neutrophilia. Although bronchodilators such as β -agonists and anticholinergics are widely used for symptomatic relief,

ABBREVIATIONS: COPD, chronic obstructive pulmonary disease; PDE, cyclic nucleotide phosphodiesterase; SPA, scintillation proximity assay; DMSO, dimethyl sulfoxide; TNF α , tumor necrosis factor- α ; PBMC, peripheral blood mononuclear cell; LPS, lipopolysaccharide; ELISA, enzyme-linked immunosorbent assay; IL, interleukin; PIP, pulmonary insufflation pressure; PD, provocative dose; BAL, bronchoalveolar lavage; MED, minimum effective dose; HIB, hyperventilation-induced bronchospasm; AUC, area under the curve; SCH 351591, *N*-(3,5-dichloro-1-oxido-4-pyridinyl)-8-methoxy-2-(trifluoromethyl)-5-quinoline carboxamide; SCH 365351, *N*-(3,5-dichloro-4-pyridinyl)-8-methoxy-2-(trifluoromethyl)-5-quinoline carboxamide.

glucocorticoids are the only drugs currently available that effectively treat inflammation in asthma but not in COPD (Bertrand, 2000; Hay, 2000). One group of potential therapies for chronic pulmonary conditions is inhibitors of type 4 cAMP-specific phosphodiesterase (PDE4), of which theophylline, a nonspecific PDE inhibitor currently available for the treatment of asthma and COPD, is considered as prototypic (Barnette and Underwood, 2000).

There are at least 11 PDE enzyme families that degrade cAMP and/or cGMP (Torphy, 1998; Giembycz, 2000). In recent years, PDE4 has been widely pursued as a target to develop selective inhibitors with the hope of reducing the adverse effects associated with nonselective inhibitors such as theophylline. PDE4 is viewed as an exciting anti-inflammatory target for several reasons: 1) leukocyte functions are suppressed by cAMP, 2) PDE4 is the predominant isoform in inflammatory and immune cells, and 3) inhibitors of PDE4 negatively regulate the functions of almost all proinflammatory and immune cells and exert widespread anti-inflammatory activities in animal models of asthma. In recent years, selective PDE4 inhibitors have entered clinical trials, but most have failed due primarily to dose-limiting emesis and gastrointestinal disturbances (Martin, 2001). Cilomilast and roflumilast represent a newer generation of PDE4 inhibitors (Barnette et al., 1998; Underwood et al., 1998; Torphy et al., 1999; Bundschuh et al., 2001; Hatzelmann and Schudt, 2001) and are now in advanced stages of clinical development, showing promising efficacy in allergic rhinitis, asthma, and COPD in phase II trials (Compton et al., 1999, 2001; Schmidt et al., 2001; Timmer et al., 2002).

In this article, we describe SCH 351591 (Fig. 1) as a novel, selective, potent PDE4 inhibitor. Oral efficacy of this compound was evaluated in several animal models of asthma, including inflammatory cell recruitment into the airways and airway hyperreactivity (two cardinal features of asthma) in allergic guinea pigs and cynomolgus monkeys, and hyper-ventilation-induced bronchospasm (a model of exercised-induced asthma) in guinea pigs. The emetic potential of SCH 351591 was evaluated in ferrets, a widely used model of emesis. We also present limited data on SCH 365351 (Fig. 1), the major, active metabolite of SCH 351591 found in mice,

rats, and monkeys, which may contribute to the efficacy of SCH 351591 in these species. We conclude from these studies that SCH 351591 exhibits a biological profile predictive of its utility in pulmonary conditions such as asthma and COPD.

Experimental Procedures

Materials. SCH 351591, SCH 365351, and cilomilast were synthesized at Celltech Chiroscience Ltd. (Cambridge, UK). Salbutamol was from Schering Plough (Kenilworth, NJ). [^3H]cAMP, [^3H]cGMP, [^3H]rolipram, scintillation proximity assay (SPA) beads, and Ficoll-Paque were from Amersham Biosciences UK, Ltd. (Little Chalfont, Buckinghamshire, UK). Rolipram was from RBI/Sigma (St. Louis, MO). *Ascaris suum* extract was from Greer Laboratories (Lenoir, North Carolina). Polyclonal human elevated IgE sera and affinity-purified polyclonal sheep anti-human IgE antibody were from The Binding Site (San Diego, CA). Heat-killed *Bordetella pertussis* was from Connaught Laboratories (North York, ON, Canada). PDE enzymes were obtained as described below. All other reagents were purchased from standard laboratory supply vendors including Sigma Chemical (St. Louis, MO) and Fisher Scientific (Springfield, NJ).

PDE Enzyme Assays. The PDE activity was determined radiometrically as described previously (Wang et al., 1997) by SPA. The assay mixture contained 50 mM Tris, pH 7.5, 8.3 mM MgCl_2 , 1.7 mM EGTA, various concentrations of inhibitor, and an aliquot of the enzyme solution in a final volume of 100 μl . After preincubation for 5 min at 30°C, the reaction was started by the addition of substrate (cAMP or cGMP). After incubation for an additional 30 min, the reaction was terminated by the addition of 900 μg of yttrium silicate SPA beads, and the vials were counted for radioactivity. Sufficient enzyme was added to achieve 15 to 20% substrate breakdown.

Compounds were dissolved in dimethyl sulfoxide (DMSO) and serially diluted with Tris-HCl buffer described above to obtain the desired final concentration of the inhibitors at a DMSO concentration of 0.5% (v/v). This DMSO concentration affected none of the PDE activities. All data were analyzed using XIFit (a feature of Microsoft Excel) to construct inhibition curves and calculate IC_{50} values. For kinetic analysis, PDE4 activity at six different cAMP concentrations spanning K_m ($\sim 5 \mu\text{M}$) was measured in the absence of inhibitor. This was repeated in the presence of six different concentrations of inhibitor. Data were analyzed by reciprocal plots ($1/v$ versus $1/s$ and s/v versus s) to determine the type of inhibition.

Human PDE4 obtained from U937 cells by anion exchange chromatography was assayed in the presence of 0.125 μM cAMP and 20,000 cpm [^3H]cAMP. Human PDE1 expressed in SF9 cells was assayed in the presence of 0.1 mM CaCl_2 , 125 U/ml calmodulin, 0.5 μM cAMP, and 20,000 cpm [^3H]cAMP. PDE2 purified from human platelets by anion exchange chromatography was assayed in the presence of 0.5 μM cGMP, 0.5 μM cAMP, and 20,000 cpm [^3H]cAMP. The PDE3 purified from human platelets by anion exchange chromatography was assayed in the presence of 0.125 μM cAMP and 20,000 cpm [^3H]cAMP. PDE5 purified from human platelets by anion exchange chromatography was measured in the presence of 0.125 μM cGMP and 20,000 cpm [^3H]cGMP. Human PDE7 purified from the HUT78 cell line by anion exchange chromatography was assayed in the presence of 0.034 μM cAMP and 20,000 cpm [^3H]cAMP.

Rolipram Binding Assay. The rolipram binding assay was performed radiometrically in 96-well MAFC NOB filter plates (Millipore Corporation, Bedford, MA). The assay mixture contained 20 mM Tris-HCl, pH 7.5, 2 mM MgCl_2 , 0.1 mM dithiothreitol, 100 μg of rat brain (excluding the cerebellum) membrane proteins, various concentrations of compound, and 0.5% (v/v) DMSO. Nonspecific binding was determined in the presence of 5 μM rolipram. The assay was started by the addition of 4 nM [^3H]rolipram (10,000 cpm). After incubation at 22°C for 1 h, the reaction mixture was filtered, washed with $3 \times 200 \mu\text{l}$ of ice-cold saline, the filters dried, 100 μl of scintillant added, and the plates left to stand for 1 h before counting for radioactivity.

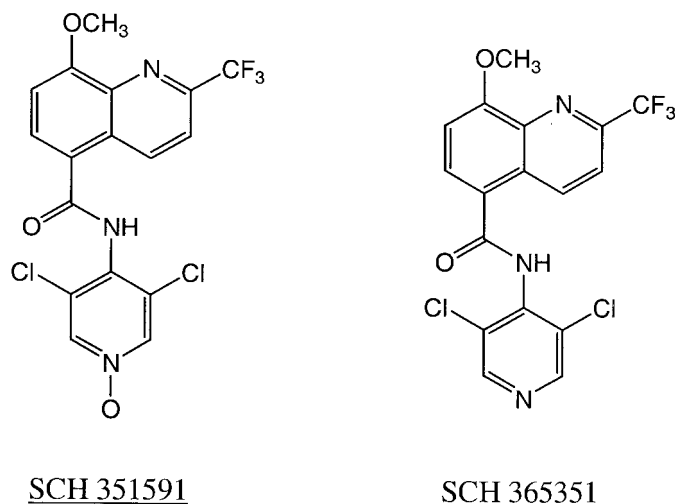

Fig. 1. Structures of SCH 351591 and SCH 365351. SCH 365351, a deoxygenated metabolite of SCH 351591, was found in variable extents in mice, rats, and monkeys.

Tumor Necrosis Factor- α (TNF α) Production by Peripheral Blood Mononuclear Cells (PBMCs). Human PBMCs were isolated from buffy coats by centrifugation on a density gradient of Ficoll-Paque. PBMCs were harvested, washed three times, resuspended at 2×10^6 /ml in RPMI 1640 medium containing 2% fetal bovine serum, and 250- μ l aliquots plated in 48-well tissue culture plates. Inhibitors were dissolved in DMSO, diluted in RPMI 1640 medium, and 100 μ l added to duplicate wells at a range of concentrations (final DMSO concentration of 0.5%). Cells were stimulated with lipopolysaccharide (LPS) at a final concentration of 100 ng/ml and incubated for 18 h at 37°C in an atmosphere of 5% CO₂ and 95% air. Cells were pelleted by centrifugation, and TNF α was measured in the supernatant by ELISA (R & D Systems, Minneapolis, MN).

Interleukin (IL)-5 Production by Human Peripheral Blood Leukocytes. Inhibitors were dissolved in DMSO, diluted in RPMI 1640 medium, and 100 μ l added to duplicate wells of a 48-well plate at a range of concentrations (final DMSO concentration of 0.5%). Buffy coat was diluted 2-fold with RPMI 1640 medium, and 200 μ l was added to each well. Cells were stimulated by the addition of 100 μ l of 10 μ g/ml phytohemagglutinin to a final concentration of 2.5 μ g/ml and 100 μ l of 500 nM phorbol-12-myristate-13-acetate solution to a final concentration of 100 nM. The plate was then incubated for 48 h at 37°C in an atmosphere of 5% CO₂ and 95% air. Cells were pelleted, and IL-5 in the supernatant was measured by ELISA (R & D Systems).

IL-12 Production by Human PBMCs. Human PBMCs were isolated from buffy coats by centrifugation on a density gradient of Ficoll-Paque. PBMCs were harvested, washed three times, resuspended at 3×10^6 /ml in serum-free RPMI 1640 medium, and 400- μ l aliquots plated in 48-well tissue culture plates. Inhibitors were dissolved in DMSO, diluted in RPMI 1640 medium, and 100 μ l added to duplicate wells at a range of concentrations (final DMSO concentration of 1%). Cells were stimulated with Pansorbin (*Staphylococcus aureus* suspension) at a final concentration of 0.075% and incubated for 18 h at 37°C in an atmosphere of 5% CO₂ and 95% air. Cells were pelleted by centrifugation, and IL-12 in the supernatant was measured by ELISA (R & D Systems).

Bronchodilator Activity in Isolated Guinea Pig Trachea. Cervical tracheal ring segments (5.0 mm in length) isolated from the Charles River Hartley strain of male guinea pigs (740–813 g) were equilibrated at 1.0 g of initial tension in Krebs' buffer (37°C) in the presence of indomethacin (2 μ M) and contracted with histamine (10 μ M). When the contraction stabilized (10–15 min), a cumulative concentration response with test compound (half-log concentration increments at 10-min intervals) was performed. The β -adrenoreceptor agonist salbutamol (10 μ M) was added at the end of each experiment to obtain a maximal reversal of the histamine-induced contraction. SCH 351591 and cilomilast stock solutions in DMSO were diluted with the assay buffer. Test compound-induced relaxations were normalized as percentage of maximum reversal.

Antiallergic Activity in Isolated Human Bronchus. Donor lung tissue was procured from five males and three females, 16 to 56 years old, by the International Institute for the Advancement of Medicine (Scranton, PA) and the Anatomic Gift Foundation (Woodbine, GA). Macroscopically normal lung tissue was procured after cancer resection from a 67-year-old female by the Cooperative Human Tissue Network (Eastern Division, University of Pennsylvania Medical Center, Philadelphia, PA). Hospital medications did not include corticosteroids, theophylline, or long-acting β -adrenergic agents. Lung tissue was received in physiological media on wet ice 20 to 48 h after removal. Bronchus segments (4–10-mm internal diameter) were isolated, prepared as 5-mm-wide epithelium-denuded transverse muscle strips, and used on the day of arrival.

Assays were performed in 37°C Krebs' buffer, pH 7.4, continuously aerated with 95% O₂, 5% CO₂ gas. Tissues were equilibrated at 1.0 g (<5-mm-diameter bronchus) or 2.0 g (>5-mm-diameter bronchus) initial tension, and a reference contraction to 30 μ M carbachol was obtained. Tissues were passively sensitized with 10% (v/v) human

IgE sera in buffer (2-h incubation), washed twice, and then incubated 30 min with SCH 351591, aminophylline, or vehicle. Contraction was induced with anti-human IgE antibody (1:1000 dilution in buffer) and followed for 90 min. Anti-human IgE antibody-induced contractions were assessed as the increase of gram tension over baseline at 10-min intervals over a period of 90 min and normalized as percentage of carbachol-induced contraction.

Induction of Cytokines in *Corynebacterium parvum*-Primed Mice. For priming with *C. parvum*, BDF1 mice were injected intravenously with 0.5 mg of heat-killed cells of ATCC strain 11827. One week after priming, mice were challenged i.v. with LPS (20 μ g/mouse). Serum cytokine levels were quantified by cytokine-specific ELISAs. The post-challenge levels of TNF α , IL-10, and IL-12 were measured in blood samples drawn at 1.5 h. Mice were dosed orally with either vehicle or SCH 351591 2 h before the LPS challenge.

LPS-Induced Pulmonary Inflammation in Rats. Male Sprague-Dawley rats (250–300 g) were anesthetized by inhalation of isoflurane (flow rate 1 ml/min; supplemented with O₂). Using a Penn-Centry microspray needle, 0.1 ml of a 100- μ g/ml LPS solution in saline was injected into the trachea. Animals not challenged with the LPS solution received 0.1 ml of saline. Animals were placed on a heat pad until they recovered from anesthesia. Afterward, they were returned to their cages and allowed food and water ad libitum. All animals survived these manipulations and no additional interventions were required to ensure their survival. Animals fasted overnight were orally dosed with either cilomilast, SCH 351591, or vehicle (0.4% methylcellulose) 2 h before the LPS challenge.

At appropriate time points after intratracheal challenge with LPS, animals were surgically prepared with a tracheal cannula. Surgery was performed under anesthesia. The airways were flushed with 2×2 ml of 0.9% saline and the two washings pooled. Lavage fluid was centrifuged (350g, 4°C, 7 min), supernatant aspirated, erythrocytes lysed, and pellet washed in phosphate-buffered saline containing 10% heat-inactivated fetal calf serum and 10 μ g/ml DNase I. The cell suspension was centrifuged, supernatant aspirated, and pellet resuspended in the same buffer. Total cell counts were performed using a Neubauer hemacytometer. Differential cell counts were conducted on Cytospin-prepared slides stained with Fisher's Leukostat stain. At least 200 cells were assessed per slide using standard morphological criteria to define mononuclear, neutrophilic, and eosinophilic cells.

Acute Allergic Bronchospasm in Guinea Pigs. Male Hartley guinea pigs were sensitized with an intraperitoneal injection (0.5 ml) of a saline suspension containing 100 mg/ml alum and 100 μ g/ml ovalbumin. Additionally, each animal was primed with an intraperitoneal injection (0.3 ml) of heat-killed *B. pertussis* (20 optical units/ml). Animals were returned to their cages and allowed food and water ad libitum. After 27 days, animals were ready for use and were fasted overnight before study.

Animals were surgically prepared with a tracheal cannula under anesthesia induced with the combination of 87 mg/kg ketamine and 15 mg/kg xylazine given intramuscularly and were then mechanically ventilated using a rodent respirator at settings of 55 breaths/min with 3 ml of inflation per breath. A side-port pressure transducer linked to a chart recorder was used to measure changes in pulmonary insufflation pressure (PIP).

While maintained on the rodent respirator, animals were exposed (15 breaths) to the aerosol of either saline or 0.1% ovalbumin generated by an ultrasonic nebulizer (model 25; DeVilbiss, Somerset, PA) and measurements of PIP were conducted throughout the exposure to saline or ovalbumin. Baseline and peak bronchospasm were recorded and the percentage of increase in PIP was calculated from these values. Two hours before the challenge, animals were orally dosed with SCH 351591, theophylline, or vehicle (0.4% methylcellulose).

Guinea Pig Model of Allergic Airway Hyperreactivity and Pulmonary Inflammation. Male Hartley guinea pigs were sensitized exactly as described above. Animals fasted overnight before the

study were exposed to two aerosol challenges, separated by 6 h, of either saline or 0.3% ovalbumin for 10 min each. The aerosol was generated by an ultrasonic nebulizer (model Ultra Neb99; DeVilbiss). To prevent anaphylactic bronchospasm, 30 min before the first antigen challenge, animals received the H₁ antagonist pyrilamine (10 mg/kg i.p.). Animals were returned to their cages and allowed food and water ad libitum.

Twenty-four hours after the first antigen challenge, animals were surgically prepared for PIP measurement as described above. Measurements of PIP were conducted before and during the intravenous administration of rising doses of acetylcholine (1, 3, 10, and 30 μ g/kg). Acetylcholine was dissolved in saline and given in a volume of 1 ml/kg for each dose. Bronchospasm to acetylcholine was expressed as the percentage of change in PIP over baseline (%PIP). Values of %PIP were plotted against the dose of acetylcholine, and a provocative dose (PD) that caused a 100% increase in PIP (PD₁₀₀) was calculated for each animal.

After the completion of acetylcholine treatment, the airways were flushed with 2 \times 3 ml of 0.9% saline, and the two washings were pooled. Total cells and eosinophils in lavaged fluid were enumerated as described above for LPS-challenged rats.

Animals were orally dosed with either SCH 351591, SCH 365351, cilomilast, or vehicle (0.4% methylcellulose), 2 h before the first antigen challenge and then again 1 h before the second antigen challenge.

Hyperventilation-Induced Bronchoconstriction in Guinea Pigs.

Studies were performed on male Hartley guinea pigs ranging in weight from 400 to 600 g. The animals were fasted overnight but given water ad libitum. Anesthesia was induced by intraperitoneal injection of 50 mg/kg sodium pentobarbital. Animals were prepared with tracheal, jugular venous, and esophageal catheters and were mechanically ventilated throughout the experiment with a rodent ventilator (Harvard Apparatus, Holliston, MA). The ventilation setting used for eupneic respiration was 1.25 ml/100 g at a frequency of 50 breaths/min.

Guinea pigs were placed in a whole-body plethysmograph and catheters connected to the outlet ports. A differential transducer measured the pressure difference across the wire mesh screen, which covered a 1-inch hole in the wall of the plethysmograph and was used to measure airflow. The airflow signal was integrated to a signal proportional to volume. Volume calibrations were performed with a 5-ml syringe. Transpulmonary pressure was measured with a differential pressure transducer (Validyne Engineering, Northridge, CA) as the pressure difference between the trachea and the esophagus. The volume, airflow, and transpulmonary pressure were monitored with a pulmonary analyzer (model 6; Buxco Electronics, Sharon, CT) and used for derivation of pulmonary resistance (R_L) and dynamic lung compliance (C_{DYN}). Both R_L and C_{DYN} were computed for each breath and digitally recorded every 6 s on a printer.

Hyperventilation was induced by increasing the respiratory rate from 50 to 185 breaths/min for 10 min. Tidal volume was not changed. After 10 min of hyperventilation, the respiratory rate was returned to the eupneic rates of 50 breaths/min. For the oral studies, the peak increase in R_L over baseline due to hyperventilation was determined in animals receiving SCH 351591, aminophylline, cilomilast, or vehicle. All treatments were given 2 h before the hyperventilation challenge. In separate studies the ability of compounds to reverse the peak bronchospasm was also evaluated. For these reversal studies, animals were hyperventilated for 10 min, and 2 min later compounds were given i.v. The changes in R_L over basal value were measured just before and then again 5 min after the i.v. administration of the compound, and these values were used to calculate percentage of reversal.

For the oral studies, SCH 351591, cilomilast, and aminophylline were given in a 0.4% methylcellulose suspension. For the i.v. studies, SCH 351591 was given in 100% DMSO (0.1 ml/animal), whereas salbutamol and aminophylline were dissolved in saline.

Pulmonary Changes in Allergic Monkeys. Twelve naturally allergic male monkeys (mean body weight 7.3 kg) were assigned to the study. On day 1 of the experiment, each animal was anesthetized with 10 mg/kg i.m. ketamine, and anesthesia was maintained by continuous intravenous infusion of 0.05 to 0.15 mg/kg/min propofol. Animals were intubated with a cuffed endotracheal tube and intermittent positive pressure ventilation started with 100% oxygen. Blood pressure, body temperature, and arterial oxygen saturation were monitored.

Bronchial reactivity to histamine was then measured. Increasing doses of intravenous histamine dihydrochloride dissolved in saline (0.1–10 μ g/kg) were given until a 100% increase in total respiratory resistance (measured using the forced oscillation technique) was obtained. Pulmonary mechanics returned to baseline between each dose of histamine. A rapid intravenous infusion of 10 ml/kg lactated Ringer's solution was given, if necessary, toward the end of the histamine dosing to maintain arterial blood pressure. Next, fiber optic bronchoscopy was performed and a bronchoalveolar lavage (BAL) obtained by instilling and then withdrawing 2 \times 10-ml aliquots of 0.9% saline into the right lung. BALs were kept on ice until processed. The plane of anesthesia was lightened and the monkeys were dosed via a stomach tube with 3 mg/kg SCH 351591 in 1 ml/kg methylcellulose vehicle followed by a 3-ml flush with vehicle, or an equal volume of vehicle alone.

Two hours later the monkeys were reanesthetized and the lungs were mechanically ventilated with 100% oxygen at 30 breaths/min with a tidal volume of 10 ml/kg to maintain end tidal CO₂ in the range 35 to 40 mm Hg. Pulmonary resistance and compliance were calculated from recordings of transpulmonary pressure and airflow. Once the mechanics measurements were stable, animals were given three vital capacity breaths, and baseline readings were taken. Each animal then inhaled 15 breaths of nebulized *A. suum* extract (Greer Laboratories) in saline at a concentration determined previously to give an acute allergic response [dilutions of 1:1–1:10,000 (v/v)]. Pulmonary mechanics were monitored for 5 min then the animals were recovered and returned to their cages.

Early in the morning of day 2 (time 24 h) each animal was anesthetized with ketamine, the histamine dose response was measured, and a BAL was performed on the left lung. After a 3-week rest period the treatments were crossed over and the experiment repeated until each animal received both treatments.

Any red blood cells present in the BAL samples were removed by lysis, and cell pellets were reconstituted in 0.9% saline. Total and differential cell counts were performed by manual methods using 200 cells for the differential count.

Ferret Emesis Assay. Male albino and fitch ferrets (0.9–1.3 kg; Eastwoods Directory Services, Godalming, Surrey, UK) were housed in groups of five per cage with free access to food and water. Compounds dissolved in syrup BP 1:1 in water were administered orally. The animals were then transferred to individual observation cages and observed continuously for a 4-h period. The behavior was recorded by videocamera, and the tapes were subsequently played back to assess emesis. Emesis was defined as rhythmic abdominal contractions that were either associated with the expulsion of the gastrointestinal contents (i.e., vomiting) or were not associated with the expulsion of the gastrointestinal contents (retching). Data are expressed as the number of animals that responded of the total number tested per dose. A dose response was constructed for each compound and at the maximum nonemetic dose, blood samples were drawn at various time points through the left jugular vein cannulae for the determination of compound concentration in the blood.

Quantification of Compound Concentration in Blood. Blood samples drawn from monkeys, guinea pigs, and ferrets were spun down, and the plasma was harvested and stored at -70°C . Aliquots of plasma samples (40 μ l) were transferred into minivials, and 100 μ l of acetonitrile containing 0.4 ng/ μ l of an internal standard was added. After vortexing and centrifugation, the supernatant was transferred to a high-performance liquid chromatography microvial.

Aliquots (30 μ l) of the supernatant were injected into a TSQ 7000 LC-APCI/MS/MS system equipped with an APCI source (Thermo Finnigan, San Jose, CA). The liquid chromatographic system included a 600 S controller, a 616 pump, and a 717 plus autosampler (Waters, Milford, MA). Chromatographic separation was achieved with a reverse phase liquid chromatography column (Luna 3 μ m, phenyl-hexyl, 50 \times 4.6 mm; Phenomenex, Torrance, CA) using an acetonitrile/water gradient. Solvent A consisted of 20:80 acetonitrile/water, with 0.6 ml of glacial acetic acid and 0.6 ml of 90% formic acid per liter of solvent. Solvent B consisted of 100% acetonitrile with 0.6 ml of glacial acetic acid and 0.6 ml of 90% formic acid. SCH 351591 ($MH^+ = 432$) and SCH 365351 ($MH^+ = 416$) were quantified using selected reaction monitoring; monitoring the product ions of $m/z = 254$ for both target compounds. The internal standard with $MH^+ = 398$ was monitored by measuring the product ion of $m/z = 378$. Argon gas at 2.0 millitorr was used for collision-activated dissociation of the precursor ions. Dwell time for each precursor-product ion transition was 0.3 s. Standard curve samples containing both target compounds were run in duplicate with the same sets. The method was found to be linear from 5 to 5000 ng/ml. The limit of quantification was 5 ng/ml for both compounds.

Statistics. For *in vivo* studies in guinea pigs, rats, and mice, comparison between groups were performed using analysis of variance, and post hoc differences were assessed using Fisher's protected least significant difference. This analysis was performed using StatView for Macintosh. Data from the monkey studies were analyzed by Student's paired *t* test.

Animal Handling. All studies using animals were done in accordance with the National Institutes of Health Guide for the Care and Use of Laboratory Animals and the Animal Welfare Act in a program approved by the American Association of the Accreditation of Laboratory Animals Care. Protocols used in these studies were approved by the Animal Care and Use Committee of Schering-Plough Research Institute.

Results

Inhibition of PDE4 and Rolipram-Binding Activity.

Hydrolysis of [3 H]cAMP to [3 H]AMP by PDE4 from human monocytic U937 cells was monitored by scintillation proximity assay. The effect of PDE4 inhibitors on high-affinity rolipram binding activity was assessed by their ability to compete with binding of [3 H]rolipram to rat brain membranes in a filtration binding assay. SCH 351591 (Fig. 1, see structure) inhibited both PDE4 activity and [3 H]rolipram binding in a concentration-dependent manner with IC_{50} values of 58 and 153 nM, respectively (Table 1). SCH 365351 (Fig. 1, see structure), the only significant circulating metabolite of SCH 351591, also inhibited both PDE4 activity ($IC_{50} = 20$ nM) and [3 H]rolipram binding ($IC_{50} = 75$ nM) with potencies greater than those of SCH 351591 (Table 1). Kinetic analyses revealed that inhibitions by these compounds of PDE4 and

TABLE 1

Inhibition of *in vitro* PDE4 activity and rolipram binding by SCH 351591, SCH 365351, and cilomilast

PDE4 was purified from cultured human monocytic U937 cells. Rolipram binding activity was measured by displacement of specific [3 H]rolipram binding to rat brain membranes. Values are displayed as geometric means with 95% confidence limits in parentheses and number of experiments in brackets.

Compound	IC_{50}	
	PDE4	RBA
	<i>nM</i>	
SCH 351591	58 (42, 81) [13]	153 (105, 223) [10]
SCH 365351	20 (14, 27) [18]	75 (49, 116) [5]
Cilomilast	86 (52, 140) [23]	27 (16, 43) [11]

TABLE 2

Inhibition of LPS-induced cytokine synthesis in blood leukocytes by SCH 351591, SCH 365351, and cilomilast

Cytokines released by LPS-treated human PBMCs ($TNF\alpha$ and IL-12) or buffy coat cells (IL-5) were measured by ELISA and concentrations that caused 50% inhibition (IC_{50}) were determined. Values are displayed as geometric means with 95% confidence limits in parentheses and number of experiments in brackets.

Compound	IC_{50}		
	$TNF\alpha$	IL-5	IL-12
	<i>nM</i>		
SCH 351591	59 (22, 157) [4]	50 (8, 324) [6]	14 (2, 86) [6]
SCH 365351	12 (2, 94) [3]	215 (115, 315) [2]	N.D.
Cilomilast	106 (50, 225) [18]	170 [1]	60 (34, 108) [5]

N.D., not done.

rolipram binding were reversible and noncompetitive (data not shown). Cilomilast inhibited PDE4 activity competitively with an IC_{50} of 86 nM (Table 1). Cilomilast was more potent than either SCH 351591 or SCH 365351 at inhibiting high-affinity [3 H]rolipram binding.

Selectivity. SCH 351591, SCH 365351, and cilomilast were tested for inhibition of PDE1, 2, 3, 5, and 7 at concentrations of 10 to 20 μ M. No significant inhibition was found (data not shown). Using cloned human PDE4 subtypes, SCH 351591 and SCH 365351 were found to inhibit all four subtypes (A, B, C, and D) equally well (data not shown), whereas cilomilast showed, as reported previously (Torphy et al., 1997), a 5- to 20-fold selectivity for D subtype over the others.

In Vitro Functional Activities. SCH 351591 and SCH 365351, like cilomilast, inhibited LPS-induced $TNF\alpha$ production by human PBMCs in a dose-dependent manner (Table

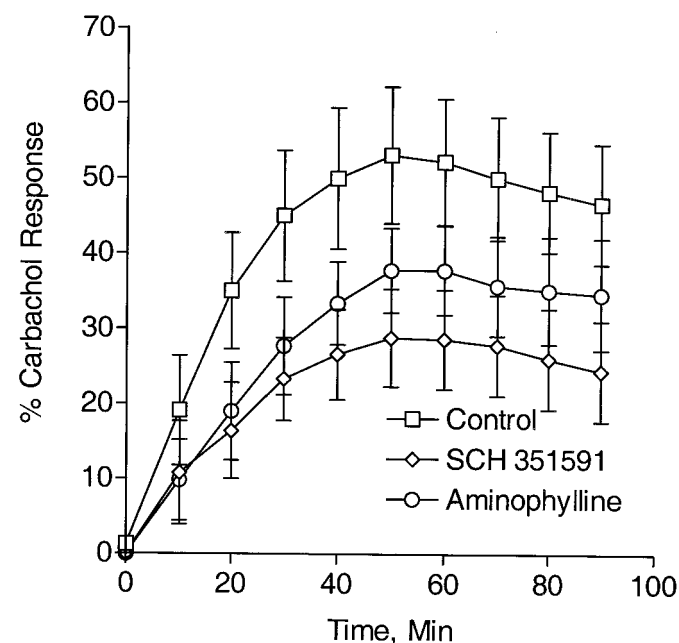

Fig. 2. Inhibition by SCH 351591 and aminophylline of anti-IgE antibody-induced contraction of isolated human bronchus. Contraction of muscle strips passively sensitized with human IgE sera was induced by anti-human IgE antibody. Contraction in the presence of vehicle, 1 μ M SCH 351591, or 1 μ M aminophylline was normalized to the 30 μ M carbachol reference contraction measured before tissue sensitization, and the values are means \pm S.E.M. ($n = 8-9$ patient determinations). Contraction, as represented by 90-min AUC estimates, was significantly inhibited by SCH 351591 ($p < 0.05$, analysis of variance with Dunnett's post hoc analysis).

2). SCH 351591 ($IC_{50} = 59$ nM) compared favorably with cilomilast ($IC_{50} = 106$ nM) but was less potent than SCH 365351 ($IC_{50} = 12$ nM). These compounds also inhibited IL-5 and IL-12 production by human blood leukocytes in a concentration-dependent manner (Table 2).

Anti-human IgE antibody induced contraction in passively sensitized isolated human bronchus. The peak contraction was significantly reduced (46%) by SCH 351591 at a concentration of 1 μ M (Fig. 2). In this assay, 1 μ M aminophylline was less effective than SCH 351591. Histamine-induced contraction of guinea pig trachea was potently reversed by the bronchodilator salbutamol (Fig. 3). In this assay, both SCH 351591 and cilomilast demonstrated poor activity, but their potencies were comparable with that of aminophylline (Fig. 3).

Inhibition of LPS-Induced Cytokine Production of Cytokine in *C. parvum*-Primed Mice. Mice previously primed with *C. parvum* produced $TNF\alpha$, IL-10, and IL-12 after an intravenous administration of LPS as measured by increases in serum levels of these cytokines. Production of $TNF\alpha$ and IL-12 was inhibited by SCH 351591 in a dose-

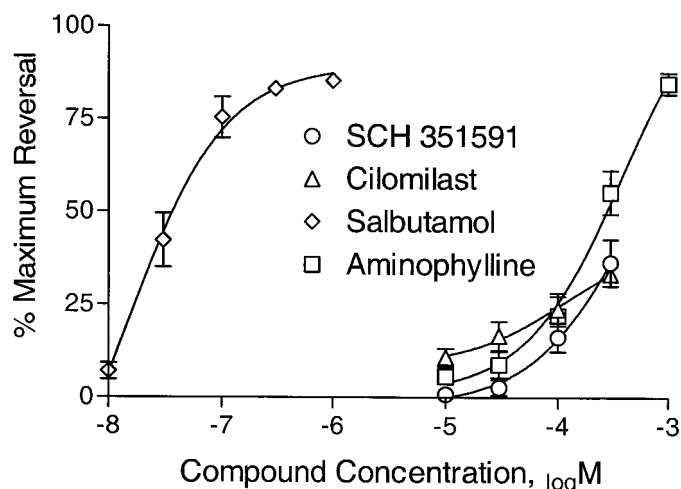

Fig. 3. Reversal of histamine-induced contractions of isolated guinea pig tracheal rings. When the contraction of tracheal rings to histamine (10 μ M) stabilized, a cumulative concentration response with each test compound was performed. Salbutamol (10 μ M) was added at the end of each experiment to obtain the maximal reversal. Values are means \pm S.E.M. of tissue responses normalized to the maximum reversal ($n = 4-8$ determinations).

TABLE 3
Effects of SCH 351591 on LPS-induced production of cytokines in *C. parvum*-primed mice

BDF1 mice primed previously with heat-killed *C. parvum* were dosed orally with indicated doses of SCH 351591 or vehicle. Two hours later, mice were challenged i.v. with LPS (20 μ g/mouse). Cytokine levels were measured by specific ELISAs in blood samples drawn 1.5 h after the challenge. Values are means \pm S.E.M. ($n = 8$ /group). Cytokines were not detectable in serum samples prepared from mice not treated with LPS. Numbers in parentheses represent percentage of inhibition.

SCH 351591 mg/kg	Serum Cytokine		
	$TNF\alpha$	IL-12	IL-10
		ng/ml	
0	2300 \pm 240	560 \pm 50	8 \pm 1
2	1360 \pm 140 (41) ^a	460 \pm 30 (19)	12 \pm 1 ^a
10	540 \pm 120 (77) ^a	300 \pm 30 (47) ^a	14 \pm 1 ^a
20	480 \pm 90 (79) ^a	260 \pm 40 (56) ^a	19 \pm 1 ^a

^a $p < 0.05$ compared with LPS control.

dependent manner with significant inhibition occurring at 2 mg/kg p.o. for $TNF\alpha$ and at 10 mg/kg p.o. for IL-12 (Table 3). In contrast, IL-10 production was enhanced by SCH 351591 treatment at all doses tested (Table 3), a finding consistent with the published observation that PDE4 inhibition enhanced the production of IL-10 in LPS-stimulated murine macrophages (Kambayashi et al., 1995).

Inhibition of LPS-Induced Lung Neutrophilia in Rats. Intratracheal administration of LPS to rats caused lung inflammation characterized by the appearance of neutrophils in the BAL fluid (Fig. 4). SCH 351591 at 3 mg/kg given orally 2 h before the LPS challenge inhibited neutrophil influx by 60%. No inhibition was seen at 0.3 mg/kg. In this model, cilomilast inhibited lung neutrophilia by 70% at

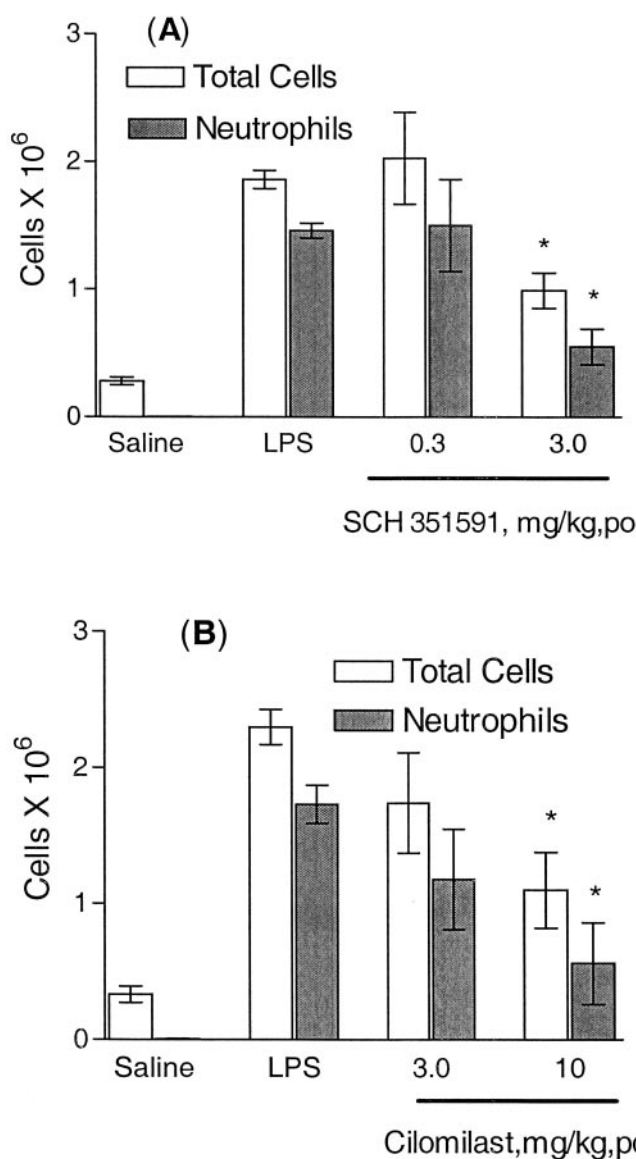

Fig. 4. Inhibition by SCH 351591 and cilomilast of LPS-induced lung neutrophilia in rats. Sprague-Dawley male rats (5/group) were dosed orally with indicated doses of either SCH 351591 or cilomilast for 2 h before intratracheal administration of 0.1 ml of a 100 μ g/ml LPS solution in saline. Eighteen hours after the LPS challenge, animals were sacrificed and the airways flushed. The BAL fluid was analyzed for total cells and neutrophils. *, $p < 0.05$ compared with LPS control.

TABLE 4

Effect of SCH 351591 on acute bronchospasm, airway reactivity, and lung inflammation in allergic guinea pigs

Two hours after a single dose of SCH 351591, sensitized guinea pigs (13–14/group) were challenged with OVA, and bronchospasm was measured and expressed as the percentage of the increase in PIP. In a separate experiment, sensitized guinea pigs (19/group) were dosed orally with SCH 351591 or vehicle 2 h before the first antigen challenge and then again 1 h before the second antigen challenge. Twenty-four hours after the first challenge, PIP to intravenous ACh was measured and the PD of ACh that caused a 100% increase in PIP (PD₁₀₀) was determined. After the completion of the acetylcholine experiment, BAL fluid was collected and analyzed for total cells and eosinophils. Numbers in parentheses represent the percentage of inhibition.

Treatment	SCH 351591	Increase in PIP	Airway Reactivity PD ₁₀₀	BAL Cells × 10 ⁶ /ml	
				Total Cells	Eosinophils
	<i>mg/kg</i>	<i>%</i>	<i>μg ACh/kg</i>		
Saline	0		11.9 ± 1	1 ± 0.2	0.2 ± 0
OVA	0	590 ± 60	7.5 ± 0.9	3.9 ± 0.4	1.4 ± 0.2
OVA	0.3	N.D.	9.3 ± 0.9	3.4 ± 0.5 (17)	1.2 ± 0.2
OVA	1.0	510 ± 50 (13)	11.2 ± 0.9 ^a	2.6 ± 0.2 (46) ^a	1 ± 0.1 (37) ^a
OVA	3.0	340 ± 50 (42) ^a	14.6 ± 1.0 ^a	2.5 ± 0.3 (50) ^a	0.8 ± 0.1 (51) ^a

ACh, acetylcholine; N.D., not done; OVA, ovalbumin.

^a *p* < 0.05 compared with OVA challenge.

10 mg/kg p.o., whereas 32% inhibition seen at 3 mg/kg was not statistically significant.

Effects on Acute Bronchospasm, Airway Hyperreactivity, and Lung Inflammation in Allergic Guinea Pigs.

Orally sensitized guinea pigs exposed to aerosolized ovalbumin developed an acute bronchospastic response. This response was significantly inhibited (71%) by theophylline (a nonselective PDE inhibitor) at a single oral dose of 100 mg/kg, given 2 h before the challenge (data not shown). When given orally, SCH 351591 inhibited (42%) bronchospasm significantly at 3 mg/kg (Table 4). However, in the same experiment, 21% inhibition observed at a higher dose (10 mg/kg) was not statistically significant (data not shown), suggesting that SCH 351591 exhibited only a partial efficacy in this model of acute bronchospasm.

When challenged with ovalbumin twice 6 h apart, actively sensitized guinea pigs developed a heightened responsiveness to acetylcholine as assessed by a reduced dose of acetylcholine for a fixed amount of response. PD₁₀₀, the i.v. dose of acetylcholine that increased PIP by 100%, was used as a measure of bronchial reactivity. PD₁₀₀ decreased significantly (*p* < 0.05) in ovalbumin-treated animals compared with control animals (Tables 4–6), demonstrating development of airway hyperreactivity. This airway hyperreactivity was dose dependently blocked by SCH 351591 as evidenced by the inhibition of the decrease in PD₁₀₀ (Table 4). Near complete inhibition of PD₁₀₀ decrease was seen at 1 mg/kg p.o. SCH 351591, but a partial inhibition at 0.3 mg/kg was not statistically significant. SCH 365351 was also effective at inhibiting airway hyperreactivity, causing a complete inhibition of PD₁₀₀ decrease at 1 mg/kg p.o. (Table 5). Interestingly, the PD₁₀₀ value in ovalbumin-treated animals dosed with 10 mg/kg SCH 365351 was substantially higher

than that in control animals (Table 5). A near complete inhibition of airway hyperreactivity by cilomilast was seen at 30 mg/kg p.o., whereas a partial inhibition at 3 mg/kg was not statistically significant (Table 6).

Sensitized animals challenged twice with antigen as described above also displayed a prominent pulmonary inflammation. This inflammation was characterized by an increase in the BAL recovery of total cells and eosinophils 24 h after the first antigen challenge (Tables 4–6). In this model, SCH 351591, given orally 2 h before the first antigen challenge and then again 1 h before the second antigen challenge, inhibited pulmonary recruitment of total cells and eosinophils in a dose-dependent manner with a minimum effective dose (MED) (defined as the minimum dose at which statistical significance is seen) of 1 mg/kg p.o. (Table 4). In a separate experiment not shown herein, the eosinophil influx in BAL fluid was inhibited by 88% at 10 mg/kg p.o. SCH 351591. SCH 365351 also was effective at inhibiting cellular influx into lungs (Table 5). In contrast, cilomilast at 30 mg/kg p.o. was ineffective at inhibiting cell migration into lungs (Table 6), although, in a separate experiment, a 30-mg/kg dose did cause a significant inhibition (51%) of total cell recruitment, but not of eosinophil recruitment. Thus, SCH 351591 is at least 30-fold more potent than cilomilast in this model.

Inhibition of Hyperventilation-Induced Bronchospasm (HIB) in Guinea Pigs. Given orally before the hyperventilation challenge, SCH 351591 dose dependently inhibited HIB with an MED of 0.3 mg/kg (Fig. 5A). SCH 351591 was about 10-times more potent than cilomilast (MED = 3 mg/kg p.o.). The nonselective PDE inhibitor aminophylline (30 mg/kg p.o.) caused an average inhibition of 43%, but this

TABLE 5

Effects of SCH 365351 on airway reactivity and lung inflammation in allergic guinea pigs

Airway reactivity and BAL cells were measured as described in Table 4. Numbers in parentheses represent the percentage of inhibition.

Treatment	SCH 365351	Airway Reactivity PD ₁₀₀	BAL Cells × 10 ⁶ /ml	
			Total Cells	Eosinophils
	<i>mg/kg</i>	<i>μg ACh/kg</i>		
Saline	0	12.7 ± 1.2	2.5 ± 0.9	0.2 ± 0.1
OVA	0	8.2 ± 1.1	5.4 ± 0.9	1.2 ± 0.3
OVA	1	14.6 ± 1.7 ^a	3.1 ± 0.7 (80) ^a	0.9 ± 0.2 (33)
OVA	3	13.6 ± 1.4 ^a	2.3 ± 0.6 (100) ^a	0.3 ± 0.1 (87) ^a
OVA	10	18.7 ± 2.2 ^a	2.5 ± 0.4 (100) ^a	0.6 ± 0.2 (63) ^a

OVA, ovalbumin.

^a *p* < 0.05 compared with OVA (*n* = 8 animals/group).

TABLE 6
Effects of cilomilast on airway reactivity and lung inflammation in allergic guinea pigs
Airway reactivity and BAL cells were measured as described in Table 4.

Treatment	Cilomilast mg/kg	Airway Reactivity PD ₁₀₀ μg ACh/kg	BAL Cells × 10 ⁶ /ml	
			Cells	Eosinophils
Saline	0	10.8 ± 1.9	0.6 ± 0.2	0.1 ± 0
OVA	0	5.4 ± 1.0	3.3 ± 0.5	1.1 ± 0.1
OVA	3	8 ± 1.8	3.4 ± 0.3	1.3 ± 0.1
OVA	30	9.9 ± 1.0 ^a	3.0 ± 0.4	1.1 ± 0.2

OVA, ovalbumin.

^a $p < 0.05$ compared with OVA ($n = 6$ animals/group).

was not statistically significant (data not shown). Maximum inhibition attained by either SCH 351591 or cilomilast was 50 to 60%.

The ability of intravenously administered SCH 351591 to reverse an ongoing HIB was evaluated in separate studies. Intravenous SCH 351591 reversed HIB in a dose-related manner with an MED of 0.3 mg/kg (Fig. 5B). Maximum reversal was 67% at 1 mg/kg. Intravenous aminophylline also produced a dose-related reversal of HIB (MED = 3 mg/kg), but was about 10-times less potent than SCH 351591. In contrast, the β -agonist salbutamol (MED = 0.001 mg/kg) was about 300-fold more potent than SCH 351591 at reversing HIB.

Inhibition of Lung Inflammation in Allergic Monkeys. When challenged with aerosolized *A. suum* extract, naturally allergic monkeys developed pulmonary inflammation characterized by an increased presence of total cells, eosinophils, and neutrophils in the bronchoalveolar lavage fluid collected 24 h after the antigen challenge (Table 7). When animals were given SCH 351591 at a single oral dose of 3 mg/kg 2 h before the antigen challenge, the influx of eosinophils in the bronchoalveolar lavage fluid was blocked by 80%. The influx of neutrophils was also inhibited. An acute bronchospasm induced by *A. suum* was unaffected by SCH 351591 (Table 7). The effect on bronchial hyperreactiv-

ity could not be ascertained because of large variability among animals (data not shown).

Induction of Emesis in Ferrets. When dosed orally with SCH 351591, one of eight ferrets retched at 8 mg/kg (Table 8). No emesis was seen at 5 mg/kg despite appreciable plasma levels ($C_{max} = 3.5 \mu\text{g/ml}$; $\text{AUC} = 26.7 \mu\text{g} \cdot \text{h/ml}$). The maximal no-effect dose for SCH 365351 was 6 mg/kg. Cilomilast was emetic at 3 mg/kg, but not at 1 mg/kg. At 1 mg/kg, the C_{max} and AUC values for cilomilast were $2.4 \mu\text{g/ml}$ and $18.3 \mu\text{g} \cdot \text{h/ml}$, respectively.

Therapeutic Ratio for SCH 351591. Studies in ferrets demonstrate that substantial plasma exposure of SCH 351591 and SCH 365351 can be achieved without emesis (see above). In the guinea pig efficacy model, SCH 351591 was active against hyperventilation-induced bronchospasm at an oral dose of 0.3 mg/kg with C_{max} and AUC values of $0.24 \mu\text{g/ml}$ and $1.7 \mu\text{g} \cdot \text{h/ml}$, respectively (Table 9). In this model, the efficacious dose of cilomilast against hyperventilation-induced bronchospasm was 3 mg/kg ($C_{max} = 0.5 \mu\text{g/ml}$; $\text{AUC} = 4.9 \mu\text{g} \cdot \text{h/ml}$). Comparison of the plasma levels of SCH 351591 at the guinea pig efficacy dose with those at the maximal no-effect dose of 5 mg/kg in ferrets ($C_{max} = 3.5 \mu\text{g/ml}$; $\text{AUC} = 26.7 \mu\text{g} \cdot \text{h/ml}$) gives a therapeutic ratio of 16 for SCH 351591 (Table 9). A similar calculation gives a therapeutic ratio of 4 for cilomilast.

Discussion

Intensive effort over the last decade to develop PDE4 inhibitors for the treatment of lung inflammatory conditions such as asthma and COPD has yielded a number of potent and selective PDE4 inhibitors (Martin, 2001). Two of these inhibitors (GlaxoSmithKline's cilomilast and Byk Gulden's roflumilast) are currently in phase III, and several others are in various stages of clinical development. In this report, we describe SCH 351591 and its metabolite SCH 365351 as novel PDE4 inhibitors with in vitro potencies comparable with cilomilast. Published studies show that roflumilast is over 100-fold more potent than cilomilast at inhibiting PDE4 enzyme and in vitro TNF α production (Hatzelmann and Schudt, 2001). SCH 351591 and SCH 365351 did not discriminate between the four PDE4 (A, B, C, and D) subtypes, but they were highly selective versus other PDE isozymes. Importantly, in several animal models of asthma, SCH 351591 showed good efficacy (oral ED₅₀ of 0.3–1 mg/kg) against lung inflammation, bronchial hyperreactivity, and hyperventilation-induced bronchospasm. In these assays, SCH 351591 was 10- to 30-fold more potent than cilomilast. In guinea pig and rat models of lung function and inflammation, orally

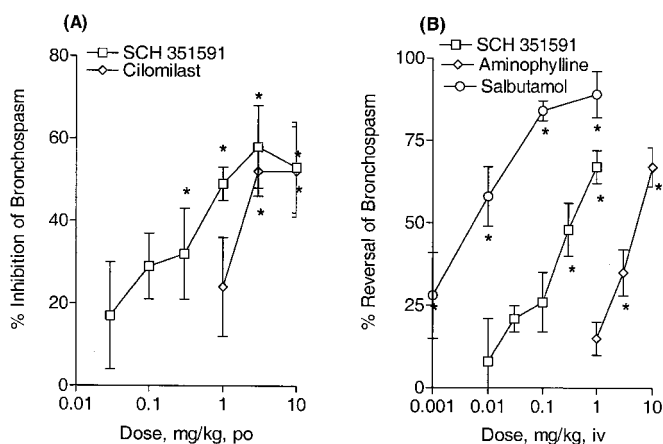

Fig. 5. Modulation by various inhibitors of HIB in guinea pigs. HIB was induced by transiently increasing the respiratory rates from 50 to 185 breaths/min. Compounds at indicated doses were given either orally 2 h before the challenge to ascertain inhibition of bronchospasm (A) or intravenously 2 min after the challenge to ascertain reversal of bronchospasm (B). Bronchospasm was measured as pulmonary resistance (R_L) and the percentage of inhibition and the percentage of reversal of bronchospasm were calculated. Values are means \pm S.E.M. ($n = 6$ –12 animals/group). *, $p < 0.05$ compared with vehicle control.

TABLE 7

Effects of SCH 351591 on *A. suum*-induced lung inflammation and acute bronchospasm in allergic monkeys

This was a placebo-controlled crossover study involving 12 naturally allergic cynomolgus monkeys. SCH 351591 (3 mg/kg) or vehicle was given orally 2 h before the challenge with *A. suum*. Immediately after the challenge, lung resistance (R_L) due to *Ascaris* was monitored for 5 min and expressed as percentage change over baseline. Twenty hours after the challenge, BAL fluid was collected and analyzed for total cells, eosinophils, and neutrophils. Values are expressed as means \pm S.E.M. ($n = 12$). Numbers in the parentheses represent the percentage of inhibition.

Treatment	BAL Cells $\times 10^6$ /ml			R_L % change due to <i>Ascaris</i>
	Total Cells	Eosinophils	Neutrophils	
Placebo	196 \pm 41	27 \pm 14	2 \pm 1	
SCH 351591	168 \pm 21	8 \pm 4	2 \pm 1	
<i>A. suum</i>	646 \pm 244	225 \pm 82	145 \pm 123	82 \pm 16
<i>Ascaris</i> and SCH 351591	272 \pm 31 (77) ^a	50 \pm 15 (79) ^a	15 \pm 6 (91) ^a	88 \pm 15

^a $p < 0.5$ compared with *A. suum* treatment only.

administered roflumilast was shown to be 30- to 300-fold more potent than cilomilast (Bundschuh et al., 2001), suggesting that the in vivo profile of roflumilast is likely to be superior to SCH 351591.

Compared by doses and by plasma levels of parent compound required for efficacy in guinea pigs and emesis in ferrets, SCH 351591 was 3- to 4-fold less emetic than cilomilast (Table 9). Several factors may contribute to the reduced emetic activity of SCH 351591. PDE4 exists in two unique conformations (Torphy et al., 1992, 1999; Torphy, 1998). One conformer binds rolipram with high affinity, and the occupation of these sites is associated with emesis and gastrointestinal disturbances. The other conformer binds rolipram much

less avidly, and inhibition of this low-affinity form is correlated with anti-inflammatory actions. SCH 351591 and SCH 365351 bind to this high-affinity conformer with reduced avidity compared with rolipram. This reduced avidity of cilomilast for high-affinity rolipram sites (about 20-fold less than that of rolipram itself) has been offered as an explanation as to why cilomilast is less emetic than rolipram (Barnette et al., 1998; Torphy et al., 1999). Recent studies using gene-disrupted mice suggest that PDE4D is more involved in emesis than PDE4B (A. Robichaud, personal communication). Notably, cilomilast inhibits PDE4D with a 5- to 10-fold greater potency than it does PDE4B, whereas SCH 351591 does not distinguish between the two subtypes. Furthermore, our unpublished data showed that cilomilast (3 mg/kg p.o.) blocked gastrointestinal mobility in rats more drastically (96%) than SCH 351591 (48% at 6 mg/kg p.o.). Thus, the improved emetic profile of SCH 351591 may be the result of several factors, including equipotency against PDE4 subtypes, reduced avidity for high-affinity rolipram binding sites, and reduced potential for gastrointestinal disturbance.

SCH 351591 exhibited a poor bronchodilatory activity in isolated guinea pig trachea (Fig. 3). However, it was more effective at inhibiting allergen-induced contraction of passively sensitized human bronchus (Fig. 2). These data are consistent with the previously suggested view that the ability of PDE4 inhibitors to suppress antigen-induced contraction is due to the inhibition of mast cell degranulation rather than to direct bronchodilation (Underwood et al., 1993, 1998). Under in vivo as well as in vitro conditions, allergen-induced contraction of human airways results from the release of mediators such as histamine and cysteinyl leukotrienes (Heaslip et al., 1992). Lung mast cells contain PDE3 and PDE4 (Giembycz, 2000), and complete inhibition of antigen-driven mediator release from these cells and of contraction of passively sensitized human airways occurs only when both PDE3 and PDE4 are inhibited (Giembycz, 2000; Schmidt et al., 2000). It is important to note that SCH 351591 (3 mg/kg p.o.) did not block allergen-induced acute bronchospasm in our allergic monkeys (Table 7). It is possible that higher doses of the compound might be needed to block mast cell mediator release in these monkeys. The finding that SCH 351591 effectively blocked lung inflammation without affecting acute bronchospasm suggests that SCH 351591 is a more potent inhibitor of inflammation than of mast cell mediator release. Reversal of hyperventilation-induced bronchospasm in guinea pigs by intravenously administered SCH 351591 (Fig. 5B) suggests that, in this model where neu-

TABLE 8

Emetic effects of SCH 351591, SCH 365351, and cilomilast in ferrets

Ferrets were monitored for emetic episodes for 4 to 6 h after oral dosing.

Compound	Emesis		
	Dose	Frequency	MND
	mg/kg		mg/kg
SCH 351591	15	1/4	5
	10	1/4	
	8	1/8	
	5	0/8	
SCH 365351	18	2/4	6
	15	1/8	
	6	0/4	
Cilomilast	10	4/4	1
	3	1/4	
	1	0/4	

MND, maximal nonemetic dose.

TABLE 9

Therapeutic indices of SCH 351591 and cilomilast

MED against hyperventilation-induced bronchospasm in guinea pigs (Fig. 5A) and maximum nonemetic dose (MND) against emesis in ferrets (Table 8) were determined under comparable experimental conditions for both compounds after a single dose.

Parameter	SCH 351591	Cilomilast
Guinea pig HIB		
MED (mg/kg p.o.)	0.3	3
C_{max} (μ g/ml) @ MED	0.24	0.5
AUC (μ g \cdot h/ml) @ MED	1.7	4.9
Ferret emesis		
MND (mg/kg p.o.)	5	1
C_{max} (μ g/ml) @ MND	3.5	2.4
AUC (μ g \cdot h/ml) @ MND	26.7	18.3
Therapeutic ratio		
C_{max} @ MND/ C_{max} @ MED	15	5
AUC @ MND/AUC @ MED	16	4

ropeptides released from the nerve endings are the major bronchospastic mediators, SCH 351591 could offer a significant bronchodilatory activity.

In recent clinical studies, orally administered cilomilast and roflumilast have been shown to improve lung function (forced expiratory volume in 1 s) significantly in patients with asthma and COPD (Compton et al., 1999, 2001; Timmer et al., 2002). This observation demonstrates that PDE4 inhibitors are capable of providing a clinically relevant level of bronchodilation in patients with asthma and COPD, despite the fact these compounds offer mild bronchodilatory activity in animal models. This beneficial effect on airflow may be attributed to the ability of cilomilast to attenuate bronchial hyperreactivity (Table 6) and hyperventilation-induced bronchospasm (Fig. 5A) and to amplify the cAMP-elevating effects of circulating catecholamines (Underwood et al., 1996). SCH 351591 was more potent than cilomilast against both bronchial hyperreactivity (Tables 4 and 6) and hyperventilation-induced bronchospasm (Fig. 5A) in our guinea pig models. Thus, SCH 351591 should compare favorably with cilomilast in its ability to improve forced expiratory volume in 1 s in patients with asthma and COPD.

It is believed that eosinophilic inflammation mediated at least in part by the cytokine network is a major contributor to the characteristic nonspecific bronchial hyperreactivity in asthma (Venge, 1990). Like other PDE4 inhibitors (Torphy, 1998), SCH 351591 exerted marked inhibitory effects on the accumulation in the lungs of neutrophils and eosinophils in several species, including rats (Table 3), guinea pigs (Table 4), and monkeys (Table 7) in response to diverse stimuli (ovalbumin, LPS, and *A. suum*). In addition, SCH 351591 inhibited the production of proinflammatory cytokine TNF α , while enhancing the production of anti-inflammatory cytokine IL-10 (Tables 2 and 3). Thus, modulation of the cytokine network and inhibition of the eosinophilic inflammation might have contributed to the effectiveness of SCH 351591 against airway hyperreactivity in allergic guinea pigs. Of note, however, in this regard is the fact that cilomilast inhibited bronchial hyperreactivity at doses where eosinophil infiltration remained unaffected (Table 6), suggesting that factors other than inflammation might be involved. One such factor may well be the inhibition of the release of inflammatory neuropeptides such as substance P from the sensory nerve endings. This is suggested by our observation that hyperventilation-induced bronchospasm, a response believed to be mediated by the release of neuropeptides (Ray et al., 1989), was effectively attenuated by SCH 351591 and cilomilast (Fig. 5A). PDE4 inhibitors such as rolipram inhibit the excitatory nonadrenergic and noncholinergic neurotransmission (Undem et al., 1994) and augment the nonadrenergic and noncholinergic relaxation of bronchus (Fernandes et al., 1994), further supporting the potential impact of PDE4 inhibitors on neuronal control of pulmonary function. It is also possible that PDE 4 inhibitors affect aspects of airway remodeling such smooth muscle hypertrophy and goblet cell metaplasia, thereby contributing to their beneficial effect on airway hyperreactivity.

SCH 351591, like other PDE4 inhibitors, affected the trafficking of neutrophils into the lungs (Tables 3 and 7). Although neutrophils are generally recognized as part of the inflammatory process in COPD but not in asthma, recent data demonstrate pronounced neutrophilia in the lungs of

asthma patients who are refractory to current treatments or suffer from severe exacerbations (Fahy et al., 1995; Wenzel et al., 1999; Norzila et al., 2000; Gibson et al., 2001). PDE4 inhibitors might prove beneficial in these patients.

In summary, we have identified SCH 351591 as a potent, selective, orally active PDE4 inhibitor. SCH 351591 blocked pulmonary inflammation and bronchial hyperreactivity in animal models of asthma and COPD with excellent potencies. This pharmacological profile of SCH 351591 coupled with its mild bronchodilatory activity indicates its potential utility as an effective oral therapy for asthma and COPD.

Acknowledgments

We thank Maureen Frydlewicz for excellent editorial assistance.

References

- Barnette MS, Christensen SB, Essayan DM, Grous M, Prabhakar U, Rush JA, Kagey-Sabotka A, and Torphy TJ (1998) SB207499 (Ariflo), a potent and selective second generation phosphodiesterase 4 inhibitor: in vitro antiinflammatory actions. *J Pharmacol Exp Ther* **284**:420–426.
- Barnette MS and Underwood DC (2000) New phosphodiesterase inhibitors as therapeutics for the treatment of chronic lung diseases. *Curr Opin Pulmon Med* **6**:164–169.
- Bertrand CP (2000) Asthma: where beyond steroids. *Curr Opin Chem Biol* **4**:407–411.
- Bundschuh DS, Eltze M, Barsig J, Lutz W, Hatzelmann A, and Beume R (2001) In vivo efficacy in airway disease models of Roflumilast, a novel orally active PDE4 inhibitor. *J Pharmacol Exp Ther* **297**:280–290.
- Compton CH, Ceder E, Nieman RB, Amit O, Langley SJ, and Sapene M (1999) Ariflo improves pulmonary function in patients with asthma: results of a study in patients taking inhaled corticosteroids. *Am J Respir Crit Care Med* **159**:A522.
- Compton CH, Gubb J, Ceder E, Nieman RB, Edelsen J, Amit O, Bakst A, Ayers JG, Creemers JPHM, Schultz-Werninghaus G, et al. (2001) Cilomilast, a selective phosphodiesterase-4 inhibitor for treatment of patients with chronic obstructive pulmonary disease: a randomized, dose-ranging study. *Lancet* **358**:265–270.
- Fahy JV, Kim KW, Liu J, and Boushey HA (1995) Prominent neutrophilic inflammation in sputum from subjects with acute asthma exacerbation. *J Allergy Clin Immunol* **95**:843–852.
- Fernandes IB, Ellis JL, and Undem BJ (1994) Potentiation of nonadrenergic noncholinergic relaxation of human isolated bronchus by selective inhibitors of phosphodiesterase isozymes. *Am J Respir Crit Care Med* **150**:1384–1390.
- Gibson P, Simpson JL, and Saltos N (2001) Heterogeneity of airway inflammation in persistent asthma: evidence of neutrophilic inflammation and increased sputum interleukin-8. *Chest* **119**:1329–1336.
- Giembycz MA (2000) Phosphodiesterase 4 Inhibitors and the treatment of asthma: where are we now and where do we go from here. *Drugs* **59**:193–212.
- Hatzelmann A and Schudt C (2001) Anti-inflammatory and immunoregulatory potential of the novel PDE4 inhibitor Roflumilast in vitro. *J Pharmacol Exp Ther* **297**:267–279.
- Hay DWP (2000) Chronic obstructive pulmonary disease: emerging therapies. *Curr Opin Chem Biol* **4**:412–419.
- Healip RJ, Hardysh BA, Berkenkopf JW, and Weichman W (1992) Effects of selective phosphodiesterase inhibitors on antigen-induced leukotriene release and leukotriene-dependent tracheal muscle contraction. *Am Rev Respir Dis* **145**:A859.
- Kambayashi T, Jacob CO, Zhou D, Mazurek N, Fong M, and Strassmann G (1995) Cyclic nucleotide phosphodiesterase type IV participates in the regulation of IL-10 and in the subsequent inhibition of TNF α and IL-6 by endotoxin-stimulated macrophages. *J Immunol* **155**:4909–4916.
- Martin TJ (2001) PDE4 inhibitors—a review of the recent patent literature. *Drugs* **4**:312–338.
- Mayer RJ and Wills-Karp M (1999) Recent insights into pathogenesis and control of asthma and atopic diseases. *Inflamm Res* **48**:469–470.
- Norzila MZ, Fakes J, Henry RL, Simpson J, and Gibson PG (2000) Interleukin-8 secretion and neutrophil recruitment accompanies induced sputum eosinophil activation in children with acute asthma. *Am J Respir Crit Care Med* **161**:769–774.
- O'Shaughnessy TC, Ansari TW, Barnes NC, and Jeffrey PK (1997) Inflammation in bronchial biopsies of subjects with chronic bronchitis: inverse relationship of CD8⁺ T lymphocytes with FEV₁. *Am J Respir Crit Care Med* **156**:852–857.
- Ray DW, Hernandez C, Leff AR, Drazen JM, and Solway J (1989) Tachykinins mediate bronchoconstriction elicited by isocapnic hyperpnea in guinea pigs. *J Appl Physiol* **66**:1108–1112.
- Roche WR (1998) Inflammatory and structural changes in the small airways in bronchial asthma. *Am J Respir Crit Care Med* **157**:S191–S194.
- Schmidt BMW, Kusma M, Feuring M, Timmer WE, Neuhauser M, Bethke T, Stuck BA, Hormann K, and Wehling M (2001) The phosphodiesterase 4 inhibitor roflumilast is effective in the treatment of allergic rhinitis. *J Allergy Clin Immunol* **108**:530–536.
- Schmidt DT, Watson T, Gordon D, Ruhlmann E, Branscheid D, Magnussen H, and Rabe KF (2000) The effects of selective and non-selective phosphodiesterase inhibitors on allergen- and leukotriene C4-induced contractions in passively sensitized airways. *Br J Pharmacol* **131**:1607–1618.
- Timmer W, Leclerc V, Birraux G, Neuhauser M, Hatzelmann A, Bethke T, and Wurst W (2002) The new phosphodiesterase 4 inhibitor roflumilast is efficacious in

- exercise-induced asthma and leads to suppression of LPS-stimulated TNF- α ex vivo. *J Clin Pharmacol* **42**:297–303.
- Torphy TJ (1998) Phosphodiesterase isozymes: molecular targets for novel anti-asthma agents. *Am J Respir Crit Care Med* **157**:361–370.
- Torphy TJ, Barnette MS, Underwood DC, Griswold DE, Christensen SB, Murdoch RD, Nieman RB, and Compton CH (1999) Airflo (SB207499), a second generation phosphodiesterase 4 inhibitor in the treatment of asthma and COPD: from concept to clinic. *Pul Pharmacol Ther* **12**:131–135.
- Torphy TJ, Christensen SB, Barnette MS, Burman M, Cieslinski LB, and Dewolf WE Jr (1997) Molecular basis for an improved therapeutic index of SB207499, a second generation phosphodiesterase 4 inhibitor. *Eur Respir J* **10**:313a.
- Torphy TJ, Stadel JM, Burman M, Cieslinski IB, McLaughlin MM, White JF, and Livi GP (1992) Coexpression of human cAMP-specific phosphodiesterase activity and high affinity rolipram binding in yeast. *J Biol Chem* **267**:1798–1804.
- Udem BJ, Meeker SN, and Chen J (1994) Inhibition of neurally mediated nonadrenergic noncholinergic relaxation of human isolated bronchus by isozyme selective phosphodiesterase inhibitors. *J Pharmacol Exp Ther* **271**:811–817.
- Underwood DC, Bochnowicz S, Osborn RR, Kotzer CJ, Luttmann MA, Hay DW, Gorycki PD, Christensen SB, and Torphy TJ (1998) Antiasthma activity of the second generation phosphodiesterase (PDE4) inhibitor SB207499 (Ariflo) in the guinea pig. *J Pharmacol Exp Ther* **287**:988–995.
- Underwood DC, Mathews JK, Osborn RR, Novak LB, Backowicz S, and Meunier (1996) Catecholamine and β -adrenoreceptor influences on airway reactivity to antigen in the guinea pig. *Int Arch Allergy Immunol* **109**:286–294.
- Underwood DC, Osborn RR, Novak LB, Mathews JK, Newsholme SJ, Udem BJ, Hand JM, and Torphy TJ (1993) Inhibition of antigen-induced bronchoconstriction and eosinophil infiltration in the guinea pig by the cyclic AMP-specific phosphodiesterase inhibitor, rolipram. *J Pharmacol Exp Ther* **266**:306–313.
- Venge P (1990) What is the role of the eosinophil. *Thorax* **45**:161–163.
- Wang P, Myers JG, Wu P, Cheewatrakoolpong B, Egan RW, and Billah MM (1997) Expression, purification, and characterization of human cAMP-specific phosphodiesterase (PDE4) subtypes A, B, C and D. *Biochem Biophys Res Commun* **234**:320–324.
- Wenzel SE, Schwartz LB, Largmack FL, Halliday JL, Trudeau JB, Gibbs RL, and Chu HW (1999) Evidence that severe asthma can be divided pathologically into two inflammatory subtypes with distinct physiologic and clinical characteristics. *Am J Respir Crit Care Med* **160**:1001–1008.

Address correspondence to: Dr. Motasim Billah, 2015 Galloping Hill Rd., K15-1-1660, Kenilworth, NJ 07033. E-mail: motasim.billah@spcorp.com
