

## Author's Accepted Manuscript

The impact of product returns and remanufacturing uncertainties on the dynamic performance of a multi-echelon closed-loop supply chain

Li Zhou, Mohamed M. Naim, Stephen M. Disney



[www.elsevier.com/locate/ijpe](http://www.elsevier.com/locate/ijpe)

PII: S0925-5273(16)30174-8  
DOI: <http://dx.doi.org/10.1016/j.ijpe.2016.07.021>  
Reference: PROECO6477

To appear in: *Intern. Journal of Production Economics*

Received date: 30 October 2015  
Revised date: 18 July 2016  
Accepted date: 27 July 2016

Cite this article as: Li Zhou, Mohamed M. Naim and Stephen M. Disney. The impact of product returns and remanufacturing uncertainties on the dynamic performance of a multi-echelon closed-loop supply chain, *Intern. Journal of Production Economics*, <http://dx.doi.org/10.1016/j.ijpe.2016.07.021>

This is a PDF file of an unedited manuscript that has been accepted for publication. As a service to our customers we are providing this early version of the manuscript. The manuscript will undergo copyediting, typesetting, and a review of the resulting galley proof before it is published in its final citable form. Please note that during the production process errors may be discovered which could affect the content, and all legal disclaimers that apply to the journal pertain.

**The impact of product returns and remanufacturing uncertainties on the  
dynamic performance of a multi-echelon closed-loop supply chain**

Li Zhou<sup>1</sup>, Mohamed M. Naim<sup>2</sup>, Stephen M. Disney<sup>2</sup>

<sup>1</sup>Faculty of Business, University of Greenwich, London, SE10 9LS, UK

<sup>2</sup>Logistics Systems Dynamics Group, Cardiff Business School, Cardiff University,  
Aberconway Building, Colum Drive, Cardiff, CF10 3EU, UK

Li.Zhou@gre.ac.uk

NaimMM@cardiff.ac.uk

DisneySM@cardiff.ac.uk

**Abstract**

We investigate a three-echelon manufacturing and remanufacturing closed-loop supply chain (CLSC) constituting of a retailer, a manufacturer and a supplier. Each echelon, apart from its usual operations in the forward SC (FSC), has its own reverse logistics (RL) operations. We assume that RL information is transparent to the FSC, and the same replenishment policies are used throughout the supply chain. We focus on the impact on dynamic performance of uncertainties in the return yield, RL lead time and the product consumption lead time. Two outcomes are studied: order rate and serviceable inventory. The results suggest that higher return yield improves dynamic performance in terms of overshoot and risk of stock-out with a unit step response as input. However, when the return yield reaches a certain level, the classic bullwhip propagation normally associated with the FSC does not always hold. The longer remanufacturing and product consumption lead times result in a higher overshoot and a longer time to recover inventory, as well as more oscillation in the step response at the upstream echelons. We also study bullwhip and inventory

variance when demand is a random variable. Our analysis suggests that higher return yield contributes to reduced bullwhip and inventory variance at the echelon level but for the CLSC as a whole the level of bullwhip may decrease as well as increase as it propagates along the supply chain. The reason for such behaviour is due to the interaction of the various model parameters and should be the subject of further analytical research. Furthermore, by studying the three-echelon CLSC, we produce a general equation for eliminating inventory offsets in an n-echelon CLSC. This is helpful to managers who wish to maintain inventory service levels in multi-echelon CLSCs.

*Keywords:* Dynamic Performance; Bullwhip; Inventory Variance; Remanufacturing; Closed-Loop Supply Chain; APIOBPCS.

## **1. Introduction**

Closed-loop supply chains (CLSCs) have been a popular research subject in the last three decades due to their recent adoption by industry. The key drivers for the industrial adoption of a CLSC are twofold: legislative pressure and economic benefit. Indeed, recently studies have demonstrated that new technology enables returns to be handled effectively, leading to an economic benefit (Atasu et al., 2008). However, uncertainties in the acquisition of used products/parts in terms of cost, quality, quantity and customer attitude are still the main barriers to achieving profitability (Wei et al., 2015; Seitz, 2007). Therefore, understanding the uncertainties and their impact on SC performance is critical for the success of a CLSC.

According to Vahdani et al., (2012), uncertainties in the CLSC can be grouped into environmental and system categories. The former refers to the performance of each

member–retailer, (re-)manufacturer and supplier–of a supply chain (SC). The latter is related to the managerial process at three levels of decision making: strategic, tactical and operational. Furthermore, Alexander et al., (2014) summarise decision making in sustainable SC management into 11 areas: pricing and cost, inventory, network, supplier selection, logistics, environmental management, risk management, performance management, life-cycle analysis, closed loop, and product recovery and recycling. This research covers, 5 out of the 11 aforementioned areas (ibid), i.e. *inventory and ordering performance management in a closed-loop SC that is involved in product recovery and recycling.*

We aim to explore the dynamics of a three-echelon CLSC constituting of a retailer, a manufacturer and a supplier. We focus on the dynamic performance of the whole CLSC. We assume that each echelon, apart from its usual operations in the forward SC, has its own reverse logistics or remanufacturing operations. These include the actions of collection, checking, sorting, product recovery and recycling, depending on the nature of the returns.

Building on the existing body of knowledge, we model each echelon based on the single-echelon study undertaken by Tang and Naim (2004), who adopted the well-established forward SC replenishment policy known as the Automated Pipeline, Inventory and Order Based Production Control System (APIOBPCS), from John et al. (1994). They coupled an APIOBPCS manufacturing model with a push-based remanufacturing process of the reverse SC. Hence, there is no feedback in the remanufacturing process as per the description by Van der Laan (1999), yielding a hybrid manufacturing–remanufacturing system commonly found in industry (Guide, 2000). The pull based remanufacturing process was studied by Zhou et al. (2006) and, although is not the subject of this study, forms the basis of future research.

In practice, there are many companies that have already adopted CLSC management approaches. As Jayaraman and Luo (2007) pointed out, a well-managed reverse logistics has become part of competitive advantages for companies. Major manufacturers of photocopy machines, such as Xerox and Canon, are remanufacturing their used products, claiming savings of several millions of US dollars (Jayaraman and Luo, 2007, Kainuma and Disney 2015). Likewise, HP launched a closed-loop cartridge recycling programme named 'Planet Partners', "which since its inception in 1991 has taken back and reprocessed 566 million ink and toner cartridges worldwide, extending to over 50 countries and covering 90 per cent of cartridges sold" (Nichols, 2014). According to the HP report, until 2014, "...HP's solution has used over 108 million pounds of recycled plastic from over 382 million HP ink cartridges...to (re-) manufacture over 2.5 billion closed-loop ink cartridges" and "More than 75% of HP ink cartridges and 24% of HP LaserJet toner cartridges contain recycled plastics" (HP, 2014). The HP cartridge CLSC is illustrated in Figure 1. In the HP closed-loop cartridge recycling process at the retailer echelon, the retailer who sells cartridges to customers also accepts the returns from the customers for refilling ink, which is undertaking a recovering process in order to resell. We assume that refilled cartridges are as good as new – a common pronouncement by remanufacturers (e.g. see All-Party Parliamentary Sustainable Resource Group, 2014). Otherwise, the returns are sent to HP recycling depots to undertake remanufacturing operations. At the HP manufacturing echelon, apart from manufacturing new cartridges, used cartridges are put through a multiphase process for remanufacturing and reprocessing, including separating materials for later use when producing 'new-like' HP inkjet cartridges. Similarly, at the HP material supplier echelon, while raw materials can be purchased from elsewhere, the suppliers themselves also extract and refine materials from

difference sources such as returned cartridges, plastic bottles, electronics, hangers, and so on. Each echelon has an information system that tracks returned parts in terms of yield and lead times at its immediate stage. The three echelons are connected through the orders placed to upstream echelons and returned parts that flow downstream.

Although there are a number of papers studying CLSCs (Tang and Naim, 2004; Zhou and Disney, 2005; Zhou et al., 2006; Hosoda et al., 2015), the majority of them focus a manufacturer and a remanufacturer in a single SC echelon. There is little research studying multiple-echelon CLSCs. Chatfield (2013) argued that using a two stage decomposition-based models significantly underestimates the bullwhip effect in a SC which may result in wrong decision-making. Chatfield's result suggests that to get more accurate dynamic insight a model of an entire SC must be considered. This justifies the need for this research which extends the single echelon two player model into a three echelon CLSC model.

Our contribution is to extend the research of Tang and Naim (2004) to a three-echelon CLSC and explore the dynamics of the order rate (ORATE) and actual inventories (AINV) at each echelon, as measured from three aspects:

- (a) the response to a step response, which gives us a *rich picture* of the system's dynamic behaviour (John et al., 1994; Zhou et al., 2010);
- (b) the order and inventory variance amplification ratios when the demand is an i.i.d. random demand (Chen and Disney, 2007); and
- (c) the mitigation against AINV offsets that are a detriment to satisfying customer demand from stock (Disney and Towill, 2005).

The paper is organised as follows. First, we review the relevant literature in Section 2. In Section 3, a model is described, and the corresponding continuous time, Laplace domain transfer functions of the CLSC against demand are derived. Section 4 analyses the system dynamics, investigates system performance via the order and inventory responses to a step input, studies bullwhip and inventory variance amplification, and explores the impact of lead time interrelationships on system dynamics. Section 5 concludes.

## **2. Literature Review**

### **2.1. System dynamic performance**

According to Chopra and Meindl (2001), ‘a SC is dynamic [system] and involves the constant flow of information, products and funds between different stages. Each stage of the SC performs different processes and interacts with other stages of the SC.’ SC dynamics consists of the interaction processes between departments and organisations (Higuchi and Troutt, 2004). It has both positive and negative aspects (Sarimveis et al., 2008). The positive aspect is effective collaboration among players in the value chain, which may lead to higher performance. On the other hand, the negative facet is independent decision making, which may result in delays and forecasting error caused by demand uncertainty, lead-time uncertainty, and different management philosophies and objectives between players in the chain (Sarimveis et al., 2008). These characteristics may lead to the expensive bullwhip effect (Lee et al., 1997; Metters, 1997; Wang and Disney, 2016).

Hence, it is important to understand how uncertainties affect system dynamics. One of the possible approaches to gaining understanding is to use control theory.

## 2.2. Modelling SC system dynamics

Forrester (1961) introduced system dynamics in the early 1960s as a modelling and simulation methodology for understanding long-term decision making in dynamic settings. A general discussion of dynamic simulation can be found in (Sterman, 2000). Towill et al. (1992) and Wikner et al., (1991), utilised system dynamics simulation to understand SC strategies for eliminating demand amplification. Other related studies can be seen in John et al. (1994), who studied the dynamic impact of work-in-progress (WIP) feedback on a single SC echelon using control theory techniques. The WIP information allowed for tighter control of the dynamics of the system, increasing stability and reducing the variance amplification effects in inventory and orders.

Hwang and Xie (2008) investigated the impact of various SC factors on system dynamics and chaotic behaviours. These factors include an exogenous factor, customer demand, and the endogenous factors of the ordering policy, information sharing and lead time. They conclude that the causes of system variability are not only exogenous and endogenous SC factors themselves, but also their interactions between them. Zhou et al. (2010) studied the three most commonly adopted strategies in an SC: Pass-Orders-Along, Demand Smoothing and Level Scheduling. They developed pragmatic rule-of-thumb guidelines for managers selecting and adopting a robust system for dealing with demand uncertainty. Fu et al. (2015) considered a four-echelon SC consisting of a retailer, wholesaler, distributor, and a manufacturer. They introduced a model predictive control strategy into an ordering policy to mitigate bullwhip.

## 2.3. Research on dynamic modelling of closed-loop SC



Early studies of inventory variance and bullwhip in CLSCs can be found in Tang and Naim (2004), Zhou and Disney (2005) and Zhou et al. (2006). Tang and Naim (2004) studied the impact of information transparency on system dynamics in a hybrid manufacturing/remanufacturing based on the APIOBPCS model (John et al., 1994). They assumed that the recovery process adopted a push policy (i.e. no inventory control policy at the recoverable stock site), concluding that information transparency improves the robustness of the system. Zhou et al. (2006) investigated the dynamic performance of the hybrid system by adopting the industrially prevalent Kanban policy in the remanufacturing loop. They studied dynamic performance based on criteria such as rise time, settling time and overshoot to find parameter settings for preferred nominal, fast and slow response systems. They highlighted that the remanufacturing process can improve the system's dynamic performance, without degrading either the environment or the economics of the SC.

Kenné et al. (2012) studied a manufacturer and remanufacturer closed-loop SC where three inventories were considered: manufacturing inventory, remanufacturing inventory and return inventory. In order to minimise inventory holding and backlog cost, both manufacturer and remanufacturer need to develop a policy to set the production rate of manufacturing and remanufacturing, respectively. In contrast, instead of just deciding the production rate, this paper examines the impact of the return rate on the dynamic performance at both the manufacturer and the remanufacturer.

Hosoda et al. (2015) investigated the benefit of getting advance notice of returns in a decentralised closed-loop SC. They assumed that market demand and return rate were stochastic and correlated to each other and that a stochastic random yield was present in the remanufacturing activities. They showed that sharing return and yield

information may reduce inventory variance, but could increase production variance. In addition, increasing return and yield rate may have a negative impact on the system. In this research, we assume that the return yield is proportional to the market demand and that the lead time of a product in the market place is exponentially distributed as in Zhou and Disney (2006).

This literature review highlights that system dynamics simulation has been used to study various CLSCs. However, there appears to be no research on the dynamics of multi-echelon CLSCs. This motivates us to investigate a three-echelon CLSC to study the pattern of system behaviour that is exhibited by multiple-echelon CLSCs.

### **3. Model Description**

We extend the single-echelon study of Tang and Naim (2004) to a three-echelon (retailer, manufacturer and supplier) CLSC, with each echelon adopting the same policy to maximise the benefits of transparency of remanufacturing flows at each echelon. Hence, information on the remanufacturing process, including the return yield, remanufacturing lead time and the product consumption lead time, is shared with the manufacturing process but limited to within the echelon. The connection between each echelon is solely through the orders placed to the nearest upstream echelon and the returns of end customer products.

The block diagram of the three-echelon CLSC is shown in Figure 2. In order to ensure consistency and benchmarking with previous studies, in particular the work of Tang and Naim (2004) which we are extending, we utilise the Laplace transform for our control engineering analysis coupled with simulation modelling. As highlighted by Zhou et al. (2006), by studying the system in the Laplace 's' domain, we focus on the time-varying characteristics of the system and the impact of shock and random stimuli.

In deriving transfer functions in the 's' domain, we exploit the classic step input as it helps to develop insights into dynamic behaviour, which is then supplemented by exploring responses to the i.i.d. random demand.

In figure 2 the solid lines represent the traditional forward operations in the SC such as selling at a retailer, manufacturing in a plant, and purchasing raw materials and delivery from a supplier. The dashed lines represent the additional reverse logistics operations such as product recovering process by the retailer, remanufacturing process by the manufacturer and material extracting/refining process by the supplier, denoted as REM1, REM2 and REM3 respectively. The APIOBPCS model (John et al., 1994) of this hybrid system can be expressed as follows: the order placed is based on the forecast of customer demand ( $AVCON$ ) *plus* a fraction ( $1/T_i$ ) of the discrepancy between actual ( $AINV$ ) and desired ( $DINV$ , set as 0) serviceable inventory levels *plus* a fraction ( $1/T_w$ ) of the discrepancy between actual working-in-process ( $WIP$ ) and target ( $T_p AVCON$ )  $WIP$  levels *minus* the completion rate of recycled/remanufactured products ( $REM$ ). In other words:

$$ORATE = Demand\ Forecast + \frac{Desired\ Inventory - Actual\ Serviceable\ Inventory}{T_i} + \frac{Target\ WIP - Actual\ WIP}{T_w} - Remanufactured\ Products \quad (1)$$

Where  $T_i$  and  $T_w$  are controllable decision variables which are made by each echelon forward SC. If we set 'desired inventory' as 0; target WIP is related to forecasted demand multiplied by  $T_p$ , an adjustable decision variable, then we have:

$$ORATE = Demand\ Forecast - \frac{1}{T_i} Actual\ Serviceable\ Inventory + \frac{T_p Demand\ Forecasting - Actual\ WIP}{T_w} - Remanufactured\ Products \quad (2)$$

Note, the demand forecasts are created with the exponential smoothing method. Figure 2 shows the duration of the forward SC operations (i.e. selling at retailer, production at manufacturer, purchasing and delivering at supplier) and the reverse SC operations (i.e. product recovering at retailer, disassembly and reprocessing at remanufacturer, material recovery and refining at supplier) are assumed to be drawn from an exponential distribution. In addition, all remanufactured products are assumed to be as-good-as-new.

In the remanufacturing process, we adopt a push-based system that assumes there is no control of the recoverable inventory. This assumption has often been made in the CLSC literature, for example see Van der Laan et al. (1999), Tang and Naim (2004) and Hosoda et al. (2015). Items are pushed into the reverse logistics operations process as soon as they are returned. It is noted that the WIP must account for the items in both manufacturing and remanufacturing processes. In addition, the orders cascades along the SC from the customer to suppliers.

As previously described, the retailer, manufacturer and supplier all have the capability to deal with returns at various levels, i.e. product, part and/or component, and material. Meanwhile each echelon also places new orders to the nearest upstream echelon. Both manufactured and remanufactured items are used to satisfy customer demand.

The following set of notation is used:

CONS (C)	consumption or sales rate from the customer
CONS (R)	consumption rate from the retailer
CONS (M)	consumption rate from the manufacturer
AVCON	average consumption in the forward pipeline
ORATE	order rate placed for new products
COMRATE	completion rate in the conventional pipeline

AINV	actual inventory of serviceable stock
DINV	desired inventory
WIP	work-in-process in the combination of forward and reverse pipeline
$j$	index variable denoting the SC echelon. $j=1$ refers to retailer; $j=2$ , manufacturer; $j=3$ , supplier.
$T_{aj}$	time to average consumption, exponential smoothing parameter
$T_{ij}$	time to adjust inventory
$T_{wj}$	time to adjust WIP
$T_{mj}$	actual forward/manufacturing pipeline lead time
$T_{pj}$	estimated pipeline lead time, a decision parameter that determines the inventory-offset error
$T_{cj}$	Time period that the products/parts/materials are held before they enter the reverse logistics operations
$T_{rj}$	actual reverse process/remanufacturing pipeline lead time
RAVCON	average consumption in the remanufacturing pipeline
RCOMRATE	recoverable rate from the remanufacturing pipeline
$s$	Laplace operator
$\alpha_j$	return yield at echelon $j$ , $0 \leq \alpha_j \leq 1$

The focus of this research is to examine how the return yield  $\alpha$ , remanufacturing lead time  $T_r$  and the consumption lead time  $T_c$  influence the system dynamics. We investigate two key variables: order rate and actual serviceable inventory level. The corresponding Laplace transform transfer functions at each echelon are derived in Appendix A. It should be noted that as initial conditions are assumed to be zero in the frequency domain, the actual responses will indicate a deviation from some initial absolute value (see Nise, 2011).

$$G_O(s)_j = \frac{ORATE}{CONS_j} \quad (3)$$

$$G_A(s)_j = \frac{AINV}{CONS_j} \quad (4)$$

We assume that each echelon adopts the same policy which means the decision variables are  $T_{ij} = T_i$  and  $T_{wj} = T_w$ . In addition, as our focus is on the uncertainties in reverse logistics, we assume that the lead times in the forward SC at each echelon are the same, i.e.  $T_{mj} = T_m$ .

Appendix A indicates that the transfer function of echelon  $j$  is the function of echelon  $j-1$  combined with echelon  $j$  related parameters:  $T_{ij}$ ,  $T_{cj}$ , and  $\alpha_j$ . Therefore, the upstream echelon has no influence on, but is affected by, the downstream echelon, and the uncertainty of demand and returns increases as we move up the CLSC.

We start by testing the initial- and final-values of the transfer functions. These checks are made to ensure that the initial conditions (via the Initial Value Theorem) and long-term behaviour (via the Final Value Theorem) behave as desired (Rasof, 1962). For ORATE and AINV, the initial values are

$$I_O(s)_j = \lim_{s \rightarrow \infty} s G_O(s) \quad \text{and} \quad I_A(s)_j = \lim_{s \rightarrow \infty} s G_A(s),$$

and the final values are,

$$F_O(s)_j = G_O(s)_j \Big|_{s=0} \quad \text{and} \quad F_A(s)_j = G_A(s)_j \Big|_{s=0}.$$

The initial and final values for ORATE and AINV at each stage are shown in Table 1.

It can be noted that the final values of ORATE are only affected by return yield  $\alpha_j$ ; while for AINV, the consumption lead time  $T_{cj}$  has no impact on its final value. From

Table 1, we can deduce the final value for the  $n^{\text{th}}$ -echelon in this CLSC as proved in

Appendix B:

$$\frac{ORATE}{CONS} \Big|_{j=n} = 1 - \sum_{j=1}^n \alpha_j \quad (5)$$

$$\frac{AINV}{CONS} \Big|_{j=n} = \frac{T_i}{T_w} \left[ \left( \sum_{j=1}^n \alpha_j - 1 \right) T_m + \left( 1 - \sum_{j=1}^{n-1} \alpha_j \right) T_{p_n} - \alpha_n T_{r_n} \right] \quad (6)$$

Subject to:  $\sum_{j=1}^n \alpha_j \geq 0$ .

Eq. (5) implies that the final value of ORATE could be negative. This might be meaningless in reality, but mathematically it holds. Eq (6) indicates that the final value of actual inventory at the  $n^{\text{th}}$  echelon is decided by the pipeline lead time and return yield. It can be adjusted through the variables  $T_i$ ,  $T_w$  and  $T_p$ . We note that  $T_a$  has no impact on the final value but the forecasting parameter does have an influence on system performance. This is in line with previous research on forward SC e.g. Dejonckheere et al., 2002.

The potential offset in the inventory levels can be avoided by adjusting the parameter  $T_{p_j}$  as shown in Table 2. We should note here that Tang and Naim (2004) derived an expression for  $T_{p_j}$  but only for a single echelon. Historically for forward SC  $T_{p_j}$  is equated to  $T_m$ , that is, there is an assumption that the estimated lead time equals the actual lead time (John et al., 1994). Tang and Naim (2004) showed, however, that for a hybrid manufacturing-remanufacturing system,  $T_{p_j}$  is now a control parameter used to eliminate inventory off-sets.

From Table 2, we extend the result for Tang and Naim (2004) so we can use mathematical induction to predict the resultant value of  $T_{pj}$  to eliminate inventory offsets at the  $n^{\text{th}}$  echelon, as shown in Appendix B. Hence,

$$T_{p_n} = \frac{\left(1 - \sum_{j=1}^n \alpha_j\right) T_m + \alpha_n T_r}{1 - \sum_{j=1}^{n-1} \alpha_j}. \quad (7)$$

In the following analysis,  $T_p$  is adjusted according to Eq (7).

#### 4. The Dynamic Impact of Product Returns and Lead Times

There are 24 variables in the system, which makes it difficult to derive analytical solutions of the complete parameter space. In order to simplify the analysis and highlight the impact of uncertainties, we start from adopting the parameter setting suggested by Tang and Naim (2004); that is,  $T_i = 8, T_m = 8, T_w = 8$  and  $T_a = 16$  at *all* echelons (unless otherwise stated), while  $T_{p_j}$  has been set according to Eq (7). As the product consumption lead-time,  $T_c$ , is generally longer than the manufacturing lead time, and the remanufacturing lead-time,  $T_r$ , is generally shorter than the manufacturing lead-time  $T_m$ , we have started our numerical investigation from  $T_m = 8, T_c = 32$  and  $T_r = 4$ . The value of  $a_j = 0.3$  was selected as it is representative of returns of PET bottles in the USA, Hosoda et al (2015).

##### 4.1. Dynamic performance with step input

We use the step response to assess the system's ability to cope with a sudden change. The step response is powerful, as from this simple shock input, the size and duration of the subsequent stock-out and the quantity of the ensuing overshoot in orders can be



readily determined, providing a rich understanding of the qualitative dynamics of the CLSC.

#### 4.1.1 Impact of the return yield $\alpha$

To understand the impact of the return yield we consider the following two scenarios:

*Scenario 1: Equal return yields,  $\alpha_1 = \alpha_2 = \alpha_3 = \alpha$ .*

First we assume that each echelon shares the same return yield,  $\alpha_1 = \alpha_2 = \alpha_3 = \alpha$ . We use this scenario as a benchmark to understand the influence of  $\alpha_j$  in general.

*Scenario 2: Convex decreasing return yield,  $\alpha_1 = \alpha$ ,  $\alpha_2 = \alpha / 2$ ,  $\alpha_3 = \alpha / 3$ .*

This scenario refers to the case when return quality is good; for instance, within the product warranty period the returned product might be resold after repair or refurbishment and the product has a much higher chance of being remanufactured in the downstream echelons. For instance, in the case of HP closed-loop cartridge recycling program, the sold cartridges are returned to retailers at a return yield  $\alpha$  of, say 80%, where half of them,  $\alpha/2=40\%$ , could be good enough to refill ink and directly resell, and  $\alpha/3=26.66\%$  of products will be recycled into plastic.

As shown in Figure 3, we start from setting all  $\alpha_i = 0$ , meaning that no returns are present in the CLSC, that is, a classic forward SC. It provides us with a benchmark to assess the influence of the returns on the CLSC.

Observation of ORATE suggests the following:

- The retailer's order rate is the least sensitive to the return yield, and higher echelons become increasingly more sensitive. This is because the accumulated pipeline lead time increases the uncertainty in the SC. To respond to this

challenge the upstream echelons have to first over-order, then under-order to the demand.

- The ORATE overshoot ranges from 33% at the retailer echelon to 250% at the supplier echelon, implying that the amplification phenomenon seems to be inevitable in a CLSC. However, others have shown that it could be alleviated if the planning system is carefully designed (Hosoda et al., 2015; Zhou et al., 2010).
- The classic cascade of increased peak orders as they are transmitted from one echelon to the next in a traditional forward SC does not always occur. With higher value of return yield there are cases where the behaviour results in complex interactions between echelons resulting in peak orders, say, for Scenario 1,  $\alpha = 0.6$ , at the manufacturer being both lower than that at the retailer and the supplier. Similar complex behaviours also result with regards to the rise and settling times.
- When the return yield reaches 50%, the supplier echelon starts suffering from large oscillations in orders and inventory levels. When  $\alpha$  is above 50%, both the manufacturer's and supplier's ORATE become negative, because their final values  $F_o(s)_2 = 1 - \alpha_1 - \alpha_2 \leq 0$  and  $F_o(s)_3 = 1 - \alpha_1 - \alpha_2 - \alpha_3 \leq 0$ . This means that with increasing returns, each echelon will mainly undertake a remanufacturing process and reduce the output of newly manufactured items. Therefore, orders placed onto the upstream echelon are reduced.

Figure 4 suggests that increasing the return yield to a certain level can reduce the risk of a stock-out. However, in general, the impact of  $\alpha$  on the retailer's inventory performance is not significant. While the retailer would welcome more high-quality

returns, the upstream echelons need to be cautious about how many returns to accept because of the chaos caused by high volume of returns that leads to higher risk of stock-out and overstock.

From the second echelon, all echelons' inventory overshoot the target (of zero), which rarely happens in a conventional SC when  $T_w = T_i$ . This results from the increased the complexity of the CLSC. Hence, the system needs extra capacity to cope with the uncertainties and to enable the system to return to its steady state within a reasonable time. This implies that carefully setting the parameters  $T_p$ ,  $T_w$  and  $T_i$  may improve dynamic performance.

It can be noted again that complex behaviours departing from the classic forward SC inventory variance phenomenon occurs with higher return yields. There is also the noticeable swing in inventory at the supplier echelon. Apart from taking longer to cope with the undershoot, the supplier has to hold a larger inventory for longer to meet customer demand, which is costly.

To summarise, suitable allocation of the returns among the actors in a CLSC helps to achieve better dynamic performance. This means that when designing a return network careful consideration should be given to how returns flow to the upstream echelons. But care is needed in understanding the complex behaviours with respect to higher return yields. We will address this further with our bullwhip and inventory variance analysis and in our discussions.

#### 4.1.2 Impact of the remanufacturing lead time, $T_r$

To investigate the influence of the lead time,  $T_r$ , we assume that all return yields equal 0.2, in total 0.6, as in Zhou et al. (2006). The varying  $T_r$  changes from 2, 4, 8, 16 to 32 while other parameters remain unchanged.

As shown in Figure 5, the results suggest the following:

- Longer remanufacturing lead times ( $T_r$ ) increase the overshoot in the order rate. This leads to more uncertainties in the system, such as changes in demand, resource allocation, transport issues, production (re-)scheduling etc. Therefore, quick recycling improves dynamic performance.
- The settling time also increases in  $T_r$  and more oscillation occurs in the upstream echelons. In particular, for the inventory, it increases the risk of both stock-out and overstock causing significant cost. This observation shows that shorter lead time results in better performance – a *rule of thumb* that works well in conventional SCs as well as CLSCs. Therefore, it is worth examining which other guidance in traditional SCs (Zhou et al., 2010) could be extended to CLSCs and how.
- When  $T_r \leq T_m$ , the impact of  $T_r$  on dynamic performance reduces. For example a 100% change in  $T_r$  (from 2 to 4 or from 4 to 8), induces less than 20% change in order rate overshoot and inventory undershoot. When  $T_r > T_m$ , the system becomes more sensitive to  $T_r$ . That is, a 100% change in  $T_r$  results in more than 60% change in both ORATE and AINV, and higher echelons exhibit even worse dynamic performance. This can be explained by the two production lead times  $T_m$  and  $T_r$  – the longer lead time dominates the other one. In our case, reducing the lead time will generally lead to better dynamic

performance; that is, less undershoot and overshoot, and shorter settling times.

Complex lead-time issues were also noticed in Hosoda et al (2015), but the behaviour of their model is significantly different to this model.

#### 4.1.3 Impact of product consumption lead time $T_c$

As shown in Figure 6, the impact pattern of  $T_c$  is similar to  $T_r$ . However, we argue that the consumption lead time – that is, the period that the product spends in the market place – tends to reflect the macro environment beyond the CLSC itself, such as it is affected regulation, policy and market attitudes.

Figure 6 suggests that shorter  $T_c$  results in better performance; that is, less undershoot and overshoot as well as quicker response times. This means that a short product life is preferable to a long product life, as it potentially leads to a system with less inertia. Based on the analysis of  $\alpha$  and  $T_r$ , we recognise the need to control the return volume and manage the remanufacturing lead time. Indeed,  $T_r$  may be closely related to the return quality: the better the quality, the less time is required to reprocess it. In both cases,  $T_c$  has a direct or indirect influence. For instance, to encourage prompt product returns, a retailer may offer a trade-in incentive, to reduce  $T_c$ , increase  $\alpha$  and, as better-quality products are returned, allows the SC to reduce  $T_r$ .

#### 4.2. Dynamic performance with random input

We now study the impact of uncertainties, i.e. the return yield, return lead-time and remanufacturing lead-time, on dynamic performance when an independent and identically distributed (i.i.d.) random demand is present. Dynamic performance is

measured as bullwhip and inventory variance amplification (Chen et al., 2000; Lee et al., 1997b);

$$Bullwhip = \frac{\sigma_{orate}^2}{\sigma_{demand(C)}^2}, \quad (8)$$

$$VarAINV = \frac{\sigma_{ainv}^2}{\sigma_{demand(C)}^2}. \quad (9)$$

Both bullwhip and inventory variance amplification have been well studied in the last three decades. It is widely accepted that bullwhip and inventory variance induce unnecessary costs (Naim, 2006). Therefore, it is important for practitioners to have an in-depth understanding of bullwhip and inventory variance. However, to obtain an accurate system dynamics performance related financial figure, a clear cost structure must be in place first (Das and Dutta, 2013; Robotis et al., 2012). This is beyond the scope of this paper.

Inventory variance determines the stock levels required to meet a given target customer service level. The higher the variance of inventory levels, the more stock will be needed to maintain customer service at the target level (Churchman et al., 1957). Both inventory variance and bullwhip directly affect SC economics (Zhou and Disney, 2006). Thus, avoiding or reducing bullwhip and inventory variance has a very real and important impact on the performance of a SC.

#### 4.2.1 Impact of the return yield, $\alpha$

Table 3 presents some numerical results from a simulation study Matlab/Simulink<sup>®</sup> over a 1000 time unit horizon. The simulation stops at  $\alpha = 0.6$ , because this is sufficient to deduce the impact pattern.

Observing Table 3, the results suggest the following:

Horizontally, a higher return yield reduces both bullwhip and AINV variance. This verifies the finding regarding the order rate: the higher the returns, the higher the remanufacturing and the smaller the production of new items, reducing the orders placed upstream.

Vertically, similar to our interpretation of the graphs in Figures 3 and 4, the classic forward SC behaviour, i.e. bullwhip and inventory variance increases from echelon to echelon, does not always hold true. Bullwhip at the manufacturer echelon may at times be less than that at the retailer, and in the case of Scenario 2,  $\alpha = 0.6$ , bullwhip decreases from one echelon to the next. There is clearly some interesting interplay regarding the various values of return yield vis-à-vis order placed at each echelon that determines the extent to the level of manufactured goods are required.

Note, when  $\alpha = 0.5$ , the result at supplier echelon becomes infinite mathematically due to a zero occurring in the denominator of  $T_{p_3}$  as shown in Table 2.

#### 4.2.2 Impact of lead times of $T_r$ and $T_c$

Analysing Figure 7, short lead times generally (but not always) lead to less bullwhip and lower inventory variances at each echelon. In more detail, Figure 7(a) shows that when  $T_r \leq T_m = 8$ , the manufacturer experiences the least bullwhip effect. When  $T_r > T_m$ , bullwhip amplifies when moving to the upstream echelons. Figure 7(b) indicates that inventory variance amplification always exists, and that  $T_r$  has a very insignificant impact on the retailer's inventory variance.

The impact of  $T_c$  is less significant compared to  $T_r$ . Within the same lead time change range (2, 32), bullwhip changes from 0.08 to 0.23 for  $T_c$  compared to the bullwhip change range (0.15, 0.8) for  $T_r$ . In the same fashion, the impact of  $T_c$  on inventory is less sensitive than that of  $T_r$ . Figure 7(c) shows that when  $T_r = T_m$  and  $T_c \leq 2T_m$  the retailer has the most bullwhip, and the manufacturer again has the least bullwhip. When  $T_c > 2T_m$  the supplier has the most bullwhip. Figure 7(d) suggests that when  $T_r = T_m$  and  $T_c \leq T_m$  the manufacturer benefits the most. When  $T_c > T_m$  the inventory variance increases in upstream echelons. Therefore, there is a potential opportunity for coordination of lead time between echelons to result in better dynamic performance as a whole in terms of bullwhip and inventory variance.

Overall, from Figure 7 we learn that shortening lead times often helps to reduce bullwhip and inventory variances. The relationship between lead times,  $T_r/T_m$  and  $T_c/T_m$ , plays an important role in deciding the value of bullwhip and inventory variance, which leads to the next section exploring how the lead-times relationship affects the system dynamics.

#### 4.2.3. Exploring the impact of lead-times relationship on system dynamics

The above analyses are based on the assumptions:  $T_i = 8$ ,  $T_w = 8$ ,  $T_a = 16$ ,  $T_m = 8$ ,  $T_c = 32$ ,  $T_r = 4$ ,  $\alpha = 0.2$  (unless otherwise stated). In particular,  $T_m = 8$  is the benchmark against the other two physical lead-times:  $T_c$  and  $T_r$ . However, in practice, the lead-times may vary. We therefore need to look at how three physical lead-times interactively affect the system dynamics. By changing the benchmarking lead-time,



$T_m$ , from 2 to 16 representing the relationship of  $T_r/T_m$  from 2 to 1/4, and  $T_c/T_m$  from 16 to 2. The simulation results are summarised in Table 4.

Table 4 reveals: first, at the entire CLSC level:

(a) the CLSC dynamic performance does not always benefit from reverse logistics, i.e. the total variance with RL operations sometimes is bigger than without RL operations. This contradicts the findings of many, such as Zhou and Disney (2005), Zhou et al., (2006) and others who claimed that reverse logistics contributes to smooth bullwhip and inventory variance in a two stage one echelon CLSC. But it verifies the argument (Chatfield, 2013) that we cannot assume that the result from one echelon holds true in an entire SC.

(b) to be more specific, when remanufacturing lead time is long, e.g.  $T_r > 2T_m$ , the CLSC overall performance reduces. This reflects reality as when reverse logistics lead-times increase, there will be no financial benefit to the corporation. For instance, if refilling a returned cartridge takes much longer than producing a new cartridge, neither retailer nor manufacturer would undertake this operation for the sake of profit. Because a longer lead time results in higher a labour cost, while remanufactured products are usually cheaper than the products produced from new materials. So, taking the manufacturing lead-time as a benchmark, the remanufacturing lead-time becomes critical to the decision whether or not to undertake reverse logistics. This also suggests that investment in technology to process returns in a more effective and efficient manner (i.e. to reduce  $T_r$ ), is certainly worthwhile.

(c) In general, a well-coordinated CLSC requires total SC lead-times to be minimised as short lead-times induce better dynamic performance.

Second, at the echelon level:

(a)  $T_c$  has an insignificant impact on system dynamics. This makes intuitive sense because the time that a product is held by a consumer is so long compared to production lead time and remanufacturing lead time that it can be ignored when considering its impact on dynamics. However, if a better return quality could be obtained from a shorter  $T_c$ , it should be encouraged from system dynamics viewpoint.

(b) in a fast to moderate speed system, i.e.  $T_m \in (2,8)$  and  $T_r \in (2,8)$ , there are opportunities for a manufacturer to be the highest beneficiary of best dynamic performance as highlighted in grey in Table 4. This might be explained in that the forward logistics operations have been managed effectively, hence the lead time  $T_m$  is short. Therefore, the manufacturer can enjoy the extra ‘incoming supplies’ from reverse logistics provided it is not too complicated to handle, i.e.  $T_r$  is relatively short.

(c) Having said this, nevertheless, a very interesting and also important phenomenon we find in the CLSC is related to that previously highlighted in Sections 4.1.1 and 4.2.1 wherein bullwhip and inventory variance does not always increase from one echelon to the next but may in fact decrease, as shown in italic underlined font in Table 4. This only occurs in the ‘fast’ systems, i.e.  $T_r$  and  $T_m \leq 4$ , and  $T_c \leq 16$ . This finding certainly creates hope for upstream echelons to achieve better performance than downstream echelons.

## 5. Conclusion

We investigated a three-echelon CLSC consisting of a retailer, manufacturer and supplier. We assumed that an APIOBPCS model is adopted by all three echelons in their manufacturing process, and a push-based policy in their remanufacturing process. We focused on the impact of the return yield, recycling process/remanufacturing lead time and product consumption lead time on the system's dynamic performance. Two variables were studied, order rate and serviceable inventory.

Our findings suggest that a higher return yield does in itself result in decreased bullwhip. But the degree to which it decreases, and the propagation between echelons, is clearly a complex interplay between control parameter settings, the degree of return yield at each echelon and the lead-times in the system.

However, the returns do contribute to less bullwhip and inventory variance overall. Return yield is typically uncontrollable and with government legislation, (such as the automotive industry's end-of-life responsibilities), there is a requirement for vehicle manufacturers to ensure that all products are disposed of safely or remanufactured. Therefore, while there is potential for rationally allocating the return yield, that is, the number of used products, to each echelon in order to get better overall performance of the CLSC, regulatory constraints might restrict such a possibility.

The impact of the remanufacturing lead time,  $T_r$ , has less impact than the return yield on the system dynamics. Larger  $T_r$  leads to a higher overshoot and a longer time to recover inventory levels, as well as more oscillation in the upstream echelons. The product consumption lead time,  $T_c$ , has a similar influence. However, in some situations  $T_c$  could be a controllable parameter through marketing and promotion. In terms of bullwhip and inventory variance, longer lead times generally increase bullwhip and inventory variance. Nevertheless, an important result is that, due to the

interaction between the various lead times, namely  $T_m$ ,  $T_r$ , and  $T_c$ , bullwhip does not always amplify along a CLSC as would be expected in a traditional forward SC. This has considerable ramifications with regard to the generalised expectations governing the bullwhip effect.

Given the regulatory constraints and physical uncertainties pertaining to the return process, our most significant contributions in this study are

(1) the ability to ensure customer service levels through maintaining inventory at an appropriate level. Hence, our general finding ensures that inventory offsets are eliminated for an n-echelon CLSC.

(2) Analysing the variances of order rate and inventory under random demand suggests that manufacturing lead time can be a good benchmark for the supplier who wishes to achieve a better performance. In particular, shortening the remanufacturing lead times results in a better dynamic performance for both step input and i.i.d. random input.

(3) Systematic study of the relationship of lead-times in an entire CLSC provides a fuller picture for corporations to understand the risks and benefits of embedding reverse logistics into a traditional forward SC. If reverse logistics operations' lead time is much longer than forward SC lead time, this will result in worse overall system dynamics performance.

(4) The finding that bullwhip and inventory variance in the CLSC may actually be reduced when propagated along the SC suggests some interesting complex interplays between model parameters, which should inspire further analytical study in order to understand root causes and to allow strategy development for upstream echelons who are typically in a disadvantageous position in traditional SC.

Our research has been limited to exploring the impact of hybrid manufacturing–remanufacturing on the dynamics of a multi-echelon CLSC. We have not attempted to design solutions for mitigating the bullwhip effect or inventory variance. Instead, we have obtained a generalised rule for avoiding inventory offset. Hence, future research is required to identify ‘optimum’ policies. We have also only considered a push-based remanufacturing policy. It may be worth examining a CLSC with other policies. Additionally, in the current system we assume that there is a linear relationship between input and output. To more closely reflect reality, further study could explore non-linear closed-loop SC models.

## Reference

- All-Party Parliamentary Sustainable Resource Group (2014) Remanufacturing: towards a resource efficient economy. Policy Connect, CAN Mezzanine, 32-36 Loman Street, London SE1 0EH.
- Alexander, A., Walker, H. and Naim, M. (2014), “Decision theory in sustainable supply chain management : a literature review”, *Supply Chain Management: An International Journal*, Vol. 19 No. 5/6, pp. 504 – 522.
- Atasu, A., Sarvary, M. and Van Wassenhove, L. (2008), “Remanufacturing as a Marketing Strategy”, *Management Science*, Vol. 54 No. 10, pp. 1731–1746.
- Chatfield, D.C. (2013), “Underestimating the bullwhip effect: a simulation study of the decomposability assumption”, *International Journal of Production Research*, Vol. 51 No. 1, pp. 230–244.
- Chen, F., Drezner, Z., Ryan, J.K. and Simchi-Levi, D. (2000), “Quantifying the Bullwhip Effect in a Simple Supply Chain: The Impact of Forecasting, Lead Times, and Information”, *Management Science*, Vol. 46 No. 3, pp. 436–443.
- Chen, Y.F. and Disney, S.M. (2007), “The myopic Order-Up-To policy with a proportional feedback controller”, *International Journal of Production Research*, Vol. 45 No. 2, pp. 351–368.
- Chopra, S. and Meindl, P. (2001), *Supply Chain Management*, Prentice-Hall, New Jersey.
- Churchman, C.W., Ackoff, R.L. and Arnoff, E.L. (1957), *Introduction to Operations Research*, John Wiley & Sons, New York.
- Das, D. and Dutta, P. (2013), “A system dynamics framework for integrated reverse supply chain with three way recovery and product exchange policy”, *Computers & Industrial Engineering*, Elsevier Ltd, Vol. 66 No. 4, pp. 720–733.

- Dejonckheere, J., Disney, S., Lambrecht, M. and Towill, D. (2002), “Transfer function analysis of forecasting induced bullwhip in supply chains”, *International Journal of Production Economics*, Vol. 78 No. 2, pp. 133–144.
- Forrester, J.W. (1961), *Industrial dynamics*, MIT Press, Cambridge, MA.
- Fu, D., Ionescu, C., Aghezzaf, E.-H. and De Keyser, R. (2015), “Quantifying and mitigating the bullwhip effect in a benchmark supply chain system by an extended prediction self-adaptive control ordering policy”, *Computers & Industrial Engineering*, Elsevier Ltd, Vol. 81, pp. 46–57.
- Henkin, L. (1960), “On Mathematical Induction”, *The American Mathematical Monthly*, Vol. 67 No. 4, pp. 323–338.
- Higuchi, T. and Troutt, M.D. (2004), “Dynamic simulation of the supply chain for a short life cycle product—Lessons from the Tamagotchi case”, *Computers & Operations Research*, Vol. 31, pp. 1097–1114.
- Hosoda, T., Disney, S.M. and Gavirneni, N. (2015), “The impact of information sharing, random yield, correlation, and lead times in closed loop supply chains”, *European Journal of Operational Research*, Elsevier Ltd., Vol. 246 No. 3, pp. 827–836.
- Hwang, H.B. and Xie, N. (2008), “Understanding supply chain dynamics: A chaos perspective”, *European Journal of Operational Research*, Vol. 184 No. 3, pp. 1163–1178.
- John, S., Naim, M.M. and Towill, D.R. (1994), “Dynamic analysis of a WIP-compensated decision support system”, *International Journal of Management Systems Design*, Vol. 1 No. 4, pp. 283–297.
- Kainuma, Y. and Disney, S.M., (2015), “The cascade reuse supply chain at Fuji Xerox: A stochastic analysis”, 26th Production and Operations Management Society Annual Conference, Washington, USA, May 8th –May 11th, 10 pages.
- Kenné, J.-P., Dejax, P. and Gharbi, A. (2012), “Production planning of a hybrid manufacturing–remanufacturing system under uncertainty within a closed-loop supply chain”, *International Journal of Production Economics*, Vol. 135 No. 1, pp. 81–93.
- Van der Laan, E.A., Salomon, M. and Dekker, R. (1999), “An investigation of leadtime effects in manufacturing/remanufacturing systems under simple push and pull control strategies.”, *European Journal of Operational Research*, Vol. 115, pp. 195–214.
- Lee, H., Padmanabhan, V. and Whang, S. (1997a), “The bullwhip effect in supply chains”, *Sloan management review*, Vol. 38 No. 3, pp. 93–102.
- Lee, H.L., Padmanabhan, V. and Whang, S. (1997b), “Information Distortion in a Supply Chain: The Bullwhip Effect”, *Management Science*, Vol. 43 No. 4, pp. 546–558.
- Metters, R. (1997), “Quantifying the bullwhip effect in supply chains”, *Journal of Operations Management*, Vol. 15, pp. 89–100.
- Naim, M.M. (2006), “The impact of the net present value on the assessment of the dynamic performance of e-commerce enabled supply chains”, *International*

*Journal of Production Economics*, Vol. 104 No. 2, pp. 382–393.

- Rasof, B. (1962), “The initial- and final-value theorems in Laplace transform theory”, *Journal of the Franklin Institute*, Vol. 274 No. 3, pp. 165–177.
- Robotis, A., Boyaci, T. and Verter, V. (2012), “Investing in reusability of products of uncertain remanufacturing cost: The role of inspection capabilities”, *International Journal of Production Economics*, Elsevier, Vol. 140 No. 1, pp. 385–395.
- Sarimveis, H., Patrinos, P., Tarantilis, C.D. and Kiranoudis, C.T. (2008), “Dynamic modelling and control of supply chain systems: A review.”, *Computers & Operations Research*, Vol. 35, pp. 3530 – 3561.
- Seitz, M. A. (2007), “A critical assessment of motives for product recovery: the case of engine remanufacturing”, *Journal of Cleaner Production*, Vol. 15 No. 11-12, pp. 1147–1157.
- Sterman, J. (2000), *Business Dynamics: Systems Thinking and Modelling for a Complex World*, McGraw-Hill, NY.
- Tang, O. and Naim, M.M. (2004), “The impact of information transparency on the dynamic behaviour of a hybrid manufacturing/remanufacturing system”, *International Journal of Production Research*, Vol. 42 No. 9, pp. 4135–4152.
- Towill, D.R., Naim, M.M. and Wikner, J. (1992), “Industrial dynamics simulation models in the design of supply chains”, *International Journal of Physical Distribution & Logistics Management*, Vol. 22 No. 5, pp. 3–13.
- Vahdani, B., Tavakkoli-Moghaddam, R., Modarres, M. and Baboli, A. (2012), “Reliable design of a forward/reverse logistics network under uncertainty: A robust-M/M/c queuing model”, *Transportation Research Part E: Logistics and Transportation Review*, Elsevier Ltd, Vol. 48 No. 6, pp. 1152–1168.
- Wang, X. and Disney, S.M. (2016), “The bullwhip effect: Progress, trends and directions”, *European Journal of Operational Research*, Elsevier Ltd, Vol. 250, No. 3, 691–701.
- Wei, S., Cheng, D., Sundin, E. and Tang, O. (2015), “Motives and barriers of the remanufacturing industry in China”, *Journal of Cleaner Production*, Elsevier Ltd, Vol. 94, pp. 340–351.
- Wikner, J., Towill, D.R. and Naim, M.M. (1991), “Smoothing supply chain dynamics”, *International Journal of Production Economics*, Vol. 22 No. 3, pp. 231–248.
- Zhou, L., Disney, S. and Towill, D.R. (2010), “A pragmatic approach to the design of bullwhip controllers”, *International Journal of Production Economics*, Elsevier, Vol. 128 No. 2, pp. 556–568.
- Zhou, L. and Disney, S.M. (2006), “Bullwhip and inventory variance in a closed loop supply chain”, *OR Spectrum*, Vol. 28 No. 1, pp. 127–149.
- Zhou, L., Naim, M.M., Tang, O. and Towill, D.R. (2006), “Dynamic performance of a hybrid inventory system with a Kanban policy in remanufacturing process”, *Omega*, Vol. 34 No. 6, pp. 585–598.

Accepted manuscript



### Appendix A: The derivation of the transfer functions of the model

There is one input, i.e. customer demand denoted as CONS, and two outputs that are being investigated, i.e. order rate (ORATE) and inventory (AINV). Their transfer functions with respect to customer demand are:

$$G_o(s)_j = \frac{ORATE}{CONS} \text{ and } G_A(s)_j = \frac{AINV}{CONS}$$

where  $j$  refers to the  $j^{th}$  echelon in the CLSC,  $j \in [1, n]$ .

Let us start from the first echelon, i.e. the retailer.

$$ORATE1 = \frac{CONS}{1 + sT_{a1}} + \frac{1}{T_{w1}} \left( \frac{CONST_{p1}}{1 + sT_{a1}} - \frac{\left( \frac{ORATE1 - COMRATE1 + REM1 - REM1(1 + T_{r1})}{s} \right)}{s} \right) - \frac{AINV1}{T_{i1}} - REM1 \quad (A1)$$

We can derive ORATE1's transfer function with respect to CONS, COMRATE1, REM1 and AINV1 from

$$COMRATE1 = \frac{ORATE1}{1 + sT_{m1}} \quad (A2)$$

$$REM1 = \frac{\alpha_1 CONS}{(1 + sT_c)(1 + sT_{r1})} \quad (A3)$$

And

$$AINV1 = \frac{COMRATE1 + REM1 - CONS}{s} \quad (A4)$$

By substituting Eq. (A2) and Eq. (A3) into Eq. (A4), then into Eq. (A1), and solving the equation,  $G_o(s)_1$  is derived

$$G_o(s)_1 = \frac{ORATE1}{CONS} = \frac{(1 + sT_{m1}) \left( \frac{sT_{i1}(-\alpha_1(1 + sT_{a1})T_{r1} + (1 + sT_c)T_{p1}(1 + sT_{r1})) + (-\alpha_1(1 + sT_{a1})(1 + sT_{i1}) + (1 + sT_c))}{(1 + s(T_{a1} + T_{i1}))(1 + sT_{r1}))T_{w1}} \right)}{(1 + sT_{a1})(1 + sT_c)(1 + sT_{r1})(T_{w1} + sT_{i1}(T_{m1} + T_{w1} + sT_{m1}T_{w1}))} \quad (A5)$$

Substituting Eq. (A2), Eq. (A3) and Eq. (A5) back into Eq. (A4), yields

$$G_A(s)_1 = \frac{AINV1}{CONS} = T_{i1} \frac{\left( \alpha_1 (T_{m1} - T_{r1} + sT_{m1}T_{w1})(1 + sT_{a1}) - (1 + sT_c)(1 + sT_{r1}) \right) \left( T_{m1} + sT_{a1}T_{m1} - T_{p1} + s(T_{a1} + T_{m1} + sT_{a1}T_{m1})T_{w1} \right)}{(1 + sT_{a1})(1 + sT_c)(1 + sT_{r1})(T_{w1} + sT_{i1}(T_{m1} + T_{w1} + sT_{m1}T_{w1}))} \quad (A6)$$

To simplify the analysis so that the impact of the uncertainties we want to analyse can

be better understood, we assume that  $T_{m1} = T_{m2} = \dots T_m$  ;  $T_{a1} = T_{a2} = \dots T_a$  ;

$$T_{i1} = T_{i2} = \dots T_i ; T_{w1} = T_{w2} = \dots T_w ; T_{p1} = T_{p2} = \dots T_p .$$

Therefore, Eq.(A5) and Eq.(A6) can be rewritten as

$$G_O(s)_1 = \frac{ORATE1}{CONS} = \frac{(1 + sT_m) \left( \begin{array}{l} sT_i((1 + sT_c)T_p(1 + sT_{r1}) - \alpha_1(1 + sT_a)T_{r1}) + \\ (1 + sT_c)(1 + s(T_a + T_i))(1 + sT_{r1}) - \end{array} \right) T_w}{(1 + sT_a)(1 + sT_c)(1 + sT_{r1})(T_w + sT_i(T_m + T_w + sT_mT_w))} , \quad (A7)$$

and

$$G_A(s)_1 = \frac{AINV1}{CONS} = T_i \frac{\left( \alpha_1 (T_m - T_{r1} + sT_mT_w)(1 + sT_a) - (1 + sT_c)(1 + sT_{r1}) \right) \left( T_m + sT_aT_m - T_p + s(T_a + T_m + sT_aT_m)T_w \right)}{(1 + sT_a)(1 + sT_c)(1 + sT_{r1})(T_w + sT_i(T_m + T_w + sT_mT_w))} . \quad (A8)$$

From the second echelon, using the same process we can derive

$$ORATE2 = \frac{ORATE1}{1 + sT_a} + \frac{1}{T_w} \left( \frac{ORATE1T_p}{1 + sT_a} - \frac{REM2(1 + T_{r2}) - REM2}{s} \right) - \frac{AINV2}{T_i} - REM2 \quad (A9)$$

Note that compared to the first echelon Eq. (A1), in Eq. (A9) on the right-hand side

(RHS), ORATE1 has replaced CONS in the first and second items.

$$COMRATE2 = \frac{ORATE2}{1 + sT_m} \quad (A10)$$

$$REM2 = \frac{\alpha_2 CONS}{(1 + sT_c)(1 + sT_{r2})} \quad (A11)$$

$$AINV2 = \frac{COMRATE2 + REM2 - ORATE1}{s} \quad (A12)$$

Again, note that in Eq. (A12), CONS is replaced by ORATE1, where

$$ORATE1 = G_o(s)_1 CONS$$

Substituting Eq. (A10) and Eq. (A11) into Eq. (A12), then into Eq. (A9), and solving the equation, the second echelon  $G_o(s)_2$  is derived.

$$G_o(s)_2 = \frac{ORATE2}{CONS} = T_i(1 + sT_m)T_w \frac{\left( \frac{(1 + sT_m)(sT_iT_p + T_w + s(T_a + T_i)T_w) - \alpha_2 sT_iT_{r2} + \alpha_2 T_w + \alpha_2 sT_iT_w}{T_iT_w + sT_iT_{r2}T_w} + \frac{\left( sT_i \left( (1 + sT_c)T_p(1 + sT_{r1}) - \alpha_1(1 + sT_a)T_{r1} \right) + \left( (1 + sT_c)(1 + s(T_a + T_i)) - \alpha_1(1 + sT_a)(1 + sT_i) \right) (1 + sT_{r1})T_w}{(1 + sT_a)^2 T_i(1 + sT_{r1})T_w(T_w + sT_i(T_m + T_w + sT_mT_w))} \right)}{(1 + sT_c)(T_w + sT_i(T_m + T_w + sT_mT_w))} \right)}{(1 + sT_c)(T_w + sT_i(T_m + T_w + sT_mT_w))} \quad (A13)$$

Substituting Eq. (A13) back into Eq. (A10), and substituting Eq. (A11), Eq. (A12)

becomes

$$G_A(s)_2 = \frac{AINV_2}{CONS} = Ti \left( \frac{\left( \frac{\left( sT_i \left( (1+sT_c)T_p(1+sT_{r1}) - \alpha_1(1+sT_a)T_{r1} \right) + \left( (1+s(T_a+T_i))(1+sT_{r1}) - \alpha_1(1+sT_a)(1+sT_i) + (1+sT_c) \right) T_w}{(1+sT_a)^2(1+sT_{r1})} \right) + \frac{\alpha_2(T_m - T_{r2} + sT_m T_w)(T_w + sT_i(T_m + T_w + sT_m T_w))}{1+sT_{r2}}}{(1+sT_m)(T_m + sT_a T_m - T_p + s(T_a + T_m + sT_a T_m)T_w)} \right)}{(1+sT_c)(T_w + sT_i(T_m + T_w + sT_m T_w))^2} \right) \quad (A14)$$

The same process is applied to the third echelon, but we have to omit the result of  $G_O(s)_3$  and  $G_A(s)_3$  due to the large size of the final results, which can be supplied on request.

Applying the same steps, we can derive the  $n^{\text{th}}$ -echelon  $G_O(s)_n$  and  $G_A(s)_n$ :

$$ORATE_n = \frac{ORATE_{n-1}}{1+sT_a} + \frac{1}{T_w} \left( \frac{ORATE_{n-1} T_p}{1+sT_a} - \frac{ORATE_n - COMRATE_n + REM_n(1+T_{rn}) - REM_n}{s} \right) - \frac{AINV_n}{T_i} - REM_n \quad (A15)$$

$$COMRATE_n = \frac{ORATE_n}{1+sT_m} \quad (A16)$$

$$REM_n = \frac{\alpha_n CONS}{(1+sT_c)(1+sT_{rn})} \quad (A17)$$

$$AINV_n = \frac{COMRATE_n + REM_n - ORATE_{n-1}}{s} \quad (A18)$$

As long as can be  $ORATE_{n-1}$  is derived, then  $G_O(s)_n$  and  $G_A(s)_n$  are obtainable.

**Appendix B: Proof by mathematical induction (Henkin, 1960).**

Proof that the multi-echelon CLSC final values of ORATE and AINV deduced from the three-echelon CLSC are true.

1. *ORATE final value*

$$F(O)_{j=n} = 1 - \sum_{j=1}^n \alpha_j \quad (\text{B1})$$

Proof: when  $j = 1$ ,  $F(O)_{j=1} = 1 - \alpha_1$  holds;

When  $j = 2$ ,  $F(O)_{j=2} = 1 - \alpha_1 - \alpha_2$  holds;

Assume that when  $j = k$ ,  $F(O)_{j=k} = 1 - \sum_{j=1}^k \alpha_j$  is true;

Then  $F(O)_{j=k} = 1 - \sum_{j=1}^k \alpha_j = 1 - \alpha_1 - \alpha_2 - \dots - \alpha_k$  is also true.

Hence, when  $j = k + 1$ ,

$$F(O)_{j=k+1} = 1 - \alpha_1 - \alpha_2 - \dots - \alpha_k - \alpha_{k+1} = 1 - \sum_{j=1}^{k+1} \alpha_j \text{ is also true.}$$

Therefore, Eq. (B1) must hold.

2. *AINV final value*

$$F(A)_{j=n} = \frac{T_i}{T_w} \left[ \left( \sum_{j=1}^n \alpha_j - 1 \right) T_m + \left( 1 - \sum_{j=1}^{n-1} \alpha_j \right) T_{p_n} - \alpha_n T_{r_n} \right] \quad (\text{B2})$$

Proof. When  $j = 1$ ,  $F(A)_{j=1} = \frac{T_i}{T_w} [(\alpha_1 - 1)T_m + T_{p1} - \alpha_1 T_{r1}]$  holds;

When  $j = 2$ ,  $F(A)_{j=2} = \frac{T_i}{T_w} [(\alpha_1 + \alpha_2 - 1)T_m + (1 - \alpha_1)T_{p2} - \alpha_2 T_{r2}]$  holds;

Assume that  $j = k$ ,  $F(A)_{j=k} = \frac{T_i}{T_w} \left[ \left( \sum_{j=1}^k \alpha_j - 1 \right) T_m + \left( 1 - \sum_{j=1}^{k-1} \alpha_j \right) T_{p_k} - \alpha_k T_{r_k} \right]$  is true;

Thus,  $F(A)_{j=k} = \frac{T_i}{T_w} [(\alpha_1 + \alpha_2 + \dots + \alpha_k - 1)T_m + (1 - \alpha_1 - \alpha_2 - \dots - \alpha_{k-1})T_{p_k} - \alpha_k T_{r_k}]$ .

Then when  $j = k + 1$ ,

$$\begin{aligned} F(A)_{j=k+1} &= \frac{T_i}{T_w} [(\alpha_1 + \alpha_2 + \dots + \alpha_k + \alpha_{k+1} - 1)T_m + (1 - \alpha_1 - \alpha_2 - \dots - \alpha_{k-1} + \alpha_k)T_{p_{k+1}} - \alpha_{k+1}T_{r_{k+1}}] \\ &= \frac{T_i}{T_w} \left[ \left( \sum_{j=1}^{k+1} \alpha_j - 1 \right) T_m + \left( 1 - \sum_{j=1}^k \alpha_j \right) T_{p_{k+1}} - \alpha_{k+1} T_{r_{k+1}} \right] \end{aligned}$$

holds.

Therefore, Eq. (B2) must hold.

3. To derive  $T_{p_n}$  at the  $n^{\text{th}}$ -echelon in order to avoid inventory offset.

To inventory avoid offset, let

$$F(A)_{j=n} = \frac{T_i}{T_w} \left[ \left( \sum_{j=1}^n \alpha_j - 1 \right) T_m + \left( 1 - \sum_{j=1}^{n-1} \alpha_j \right) T_{p_n} - \alpha_n T_{r_n} \right] = 0$$

$$\text{That is } \left( \sum_{j=1}^n \alpha_j - 1 \right) T_m + \left( 1 - \sum_{j=1}^{n-1} \alpha_j \right) T_{p_n} - \alpha_n T_{r_n} = 0$$

$$\text{Therefore, } T_{p_n} = \frac{\left( 1 - \sum_{j=1}^n \alpha_j \right) T_m + \alpha_n T_{r_n}}{1 - \sum_{j=1}^{n-1} \alpha_j}. \quad (\text{B3})$$

Table 1. Initial and final value of the three-echelon CLSC system

Measures	Initial value	Final value
$\left. \frac{ORATE}{CONS} \right _{j=1}$	0	$1 - \alpha_1$
$\left. \frac{AINV}{CONS} \right _{j=1}$	0	$T_i \frac{(\alpha_1 - 1)T_m + T_{p1} - \alpha_1 T_{r1}}{T_w}$
$\left. \frac{ORATE}{CONS} \right _{j=2}$	0	$1 - \alpha_1 - \alpha_2$
$\left. \frac{AINV}{CONS} \right _{j=2}$	0	$T_i \frac{(\alpha_1 + \alpha_2 - 1)T_m + (1 - \alpha_1)T_{p2} - \alpha_2 T_{r2}}{T_w}$
$\left. \frac{ORATE}{CONS} \right _{j=3}$	0	$1 - \alpha_1 - \alpha_2 - \alpha_3$
$\left. \frac{AINV}{CONS} \right _{j=3}$	0	$\frac{T_i}{T_w} \left( \begin{aligned} &((\alpha_1 + \alpha_2 + \alpha_3 - 1)T_m \\ &+ (1 - \alpha_1 - \alpha_2)T_{p3} - \alpha_3 T_{r3}) \end{aligned} \right)$

Table 2.  $T_p$  for no inventory offset

Measures	To avoid inv. off-set
$\left. \frac{AINV}{CONS} \right _{j=1}$	$T_{p1} = (1 - \alpha_1)T_m + \alpha_1 T_{r1}$
$\left. \frac{AINV}{CONS} \right _{j=2}$	$T_{p2} = \frac{(1 - \alpha_1 - \alpha_2)T_m + \alpha_2 T_{r2}}{1 - \alpha_1}$
$\left. \frac{AINV}{CONS} \right _{j=3}$	$T_{p3} = \frac{(1 - \alpha_1 - \alpha_2 - \alpha_3)T_m + \alpha_3 T_{r3}}{1 - \alpha_1 - \alpha_2}$

Table 3. Bullwhip and AINV variance amplification

Scenario		$\alpha$	0	0.1	0.2	0.3	0.4	0.5	0.6
Bullwhip	1	Retailer	0.1875	0.1788	0.1705	0.1626	0.1552	0.1474	0.1414
		Manufacturer	0.1979	0.1762	0.1557	0.1362	0.1173	0.0967	0.0789
		Supplier	0.3047	0.2568	0.2104	0.1622	0.0987	NA*	0.1965
	2	Retailer	0.1875	0.1788	0.1705	0.1626	0.1552	0.1474	0.1414
		Manufacturer	0.1979	0.1862	0.1728	0.1579	0.1412	0.1227	0.1014
		Supplier	0.3047	0.2865	0.2654	0.2389	0.207	0.1633	0.0315
Inventory Variance	1	Retailer	7.333	7.295	7.258	7.22	7.183	7.143	7.11
		Manufacturer	10.06	9.422	8.817	8.242	7.695	7.133	6.729
		Supplier	16.84	14.86	12.96	11.11	9.604	NA*	10.97
	2	Retailer	7.333	7.295	7.258	7.22	7.183	7.143	7.11
		Manufacturer	10.06	9.53	9.004	8.48	7.955	7.43	6.911
		Supplier	16.84	15.88	14.77	13.49	12.01	10.24	13.32

\*: The special case that  $ORATE3$  and  $AINV3$  become infinite expression due to a zero occurring in the denominator of  $T_{p_3}$ .

$$T_i = 8; T_m = 8; T_w = 8; T_a = 16; T_c = 32; T_r = 4$$

Table 4. The impact of the lead-times and their relationships on system dynamics

$T_m$	Var.	Echelon	$T_r$					$T_c$				
			2	4	8	16	32	2	4	8	16	32
BW		Retailer	0.12	0.13	0.13	0.15	0.18	0.09	0.10	0.11	0.12	0.13
		Manufacturer	0.08	0.09	0.10	0.13	0.20	0.05	0.05	0.06	0.07	0.09
		Supplier	0.08	0.09	0.11	0.18	0.36	0.05	0.05	0.05	0.07	0.09
2	VarINV	Retailer	4.31	4.29	4.26	4.26	4.68	4.17	4.18	4.21	4.25	4.29
		Manufacturer	3.06	3.17	3.37	3.88	5.91	2.21	2.29	2.54	2.88	3.17
		Supplier	3.04	3.28	3.84	5.44	12.34	1.94	1.86	2.09	2.68	3.28
<b>Total (<math>\alpha=0.2</math>)</b>			<b>10.07</b>	<b>11.05</b>	<b>11.82</b>	<b>14.04</b>	<b>23.67</b>	<b>8.51</b>	<b>8.52</b>	<b>9.05</b>	<b>10.06</b>	<b>11.05</b>



		<b>Total (<math>\alpha=0</math>)</b>	<b>11.80</b>									
		Retailer	0.14	0.14	0.15	0.17	0.20	0.10	0.11	0.12	0.13	0.14
	BW	Manufacturer	0.10	0.11	0.12	0.16	0.24	0.06	0.06	0.07	0.09	0.11
		Supplier	0.11	0.12	0.15	0.23	0.47	0.07	0.06	0.07	0.09	0.12
4		Retailer	5.53	5.53	5.51	5.51	5.91	5.15	5.24	5.35	5.46	5.53
	VarINV	Manufacturer	4.80	4.99	5.34	6.11	8.66	3.27	3.44	3.88	4.50	4.99
		Supplier	5.43	5.87	6.85	9.38	18.85	3.26	3.19	3.67	4.48	5.87
		<b>Total (<math>\alpha=0.2</math>)</b>	<b>16.11</b>	<b>16.76</b>	<b>18.12</b>	<b>21.56</b>	<b>34.33</b>	<b>11.92</b>	<b>12.09</b>	<b>13.17</b>	<b>14.75</b>	<b>16.76</b>
		<b>Total (<math>\alpha=0</math>)</b>	<b>18.51</b>									
		Retailer	0.17	0.17	0.18	0.20	0.24	0.13	0.14	0.15	0.16	0.17
	BW	Manufacturer	0.15	0.16	0.18	0.22	0.32	0.09	0.09	0.11	0.13	0.16
		Supplier	0.19	0.21	0.26	0.38	0.73	0.12	0.11	0.13	0.17	0.21
8		Retailer	7.23	7.26	7.26	7.23	7.49	6.47	6.65	6.89	7.12	7.26
	VarINV	Manufacturer	8.49	8.82	9.42	10.59	13.87	5.62	5.96	6.79	7.93	8.82
		Supplier	12.08	12.96	14.90	19.93	34.09	7.70	7.15	8.34	10.72	12.96
		<b>Total (<math>\alpha=0.2</math>)</b>	<b>28.30</b>	<b>29.57</b>	<b>32.18</b>	<b>38.55</b>	<b>56.74</b>	<b>20.13</b>	<b>20.10</b>	<b>22.41</b>	<b>26.23</b>	<b>29.57</b>
		<b>Total (<math>\alpha=0</math>)</b>	<b>34.92</b>									
		Retailer	0.24	0.24	0.25	0.28	0.32	0.19	0.20	0.22	0.23	0.24
	BW	Manufacturer	0.29	0.31	0.34	0.41	0.58	0.19	0.20	0.23	0.27	0.31
		Supplier	0.51	0.56	0.66	0.92	1.64	0.35	0.35	0.39	0.48	0.56
16		Retailer	9.21	9.28	9.32	9.27	9.27	7.89	8.18	8.60	9.03	9.28
	VarINV	Manufacturer	16.18	16.72	17.69	19.32	23.48	11.00	11.67	13.14	15.15	16.72
		Supplier	32.73	34.68	38.87	48.11	72.83	20.55	21.27	24.36	29.82	34.68
		<b>Total (<math>\alpha=0.2</math>)</b>	<b>59.16</b>	<b>61.79</b>	<b>67.14</b>	<b>78.31</b>	<b>108.12</b>	<b>40.17</b>	<b>41.87</b>	<b>46.94</b>	<b>54.98</b>	<b>61.79</b>
		<b>Total (<math>\alpha=0</math>)</b>	<b>81.79</b>									
		Retailer	0.42	0.42	0.44	0.47	0.53	0.35	0.37	0.39	0.41	0.42
	BW	Manufacturer	0.88	0.92	0.99	1.15	1.50	0.67	0.70	0.77	0.85	0.92
32		Supplier	2.55	2.73	3.13	4.04	6.40	1.97	2.01	2.20	2.50	2.73
		Retailer	11.14	11.26	11.38	11.37	11.16	9.14	9.53	10.12	10.78	11.26
	VarINV	Manufacturer	33.40	34.25	35.78	38.31	43.27	24.50	25.72	28.24	31.61	34.25

---

Supplier	112.80	117.70	128.00	149.20	199.10	81.85	84.74	93.14	106.50	117.70
<b>Total (<math>\alpha=0.2</math>)</b>	<b>161.18</b>	<b>167.28</b>	<b>179.73</b>	<b>204.55</b>	<b>261.96</b>	<b>118.48</b>	<b>123.07</b>	<b>134.86</b>	<b>152.65</b>	<b>167.28</b>
<b>Total (<math>\alpha=0</math>)</b>	<b>263.50</b>									

---

Accepted manuscript

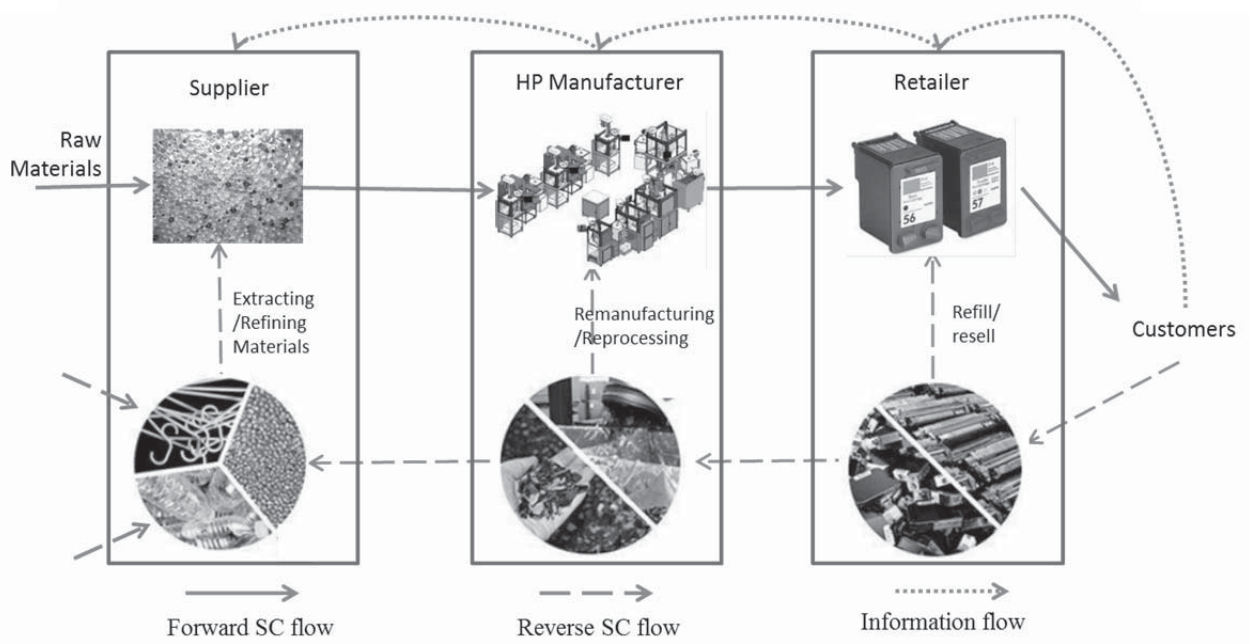

Figure 1. A three-echelon cartridge CLSC

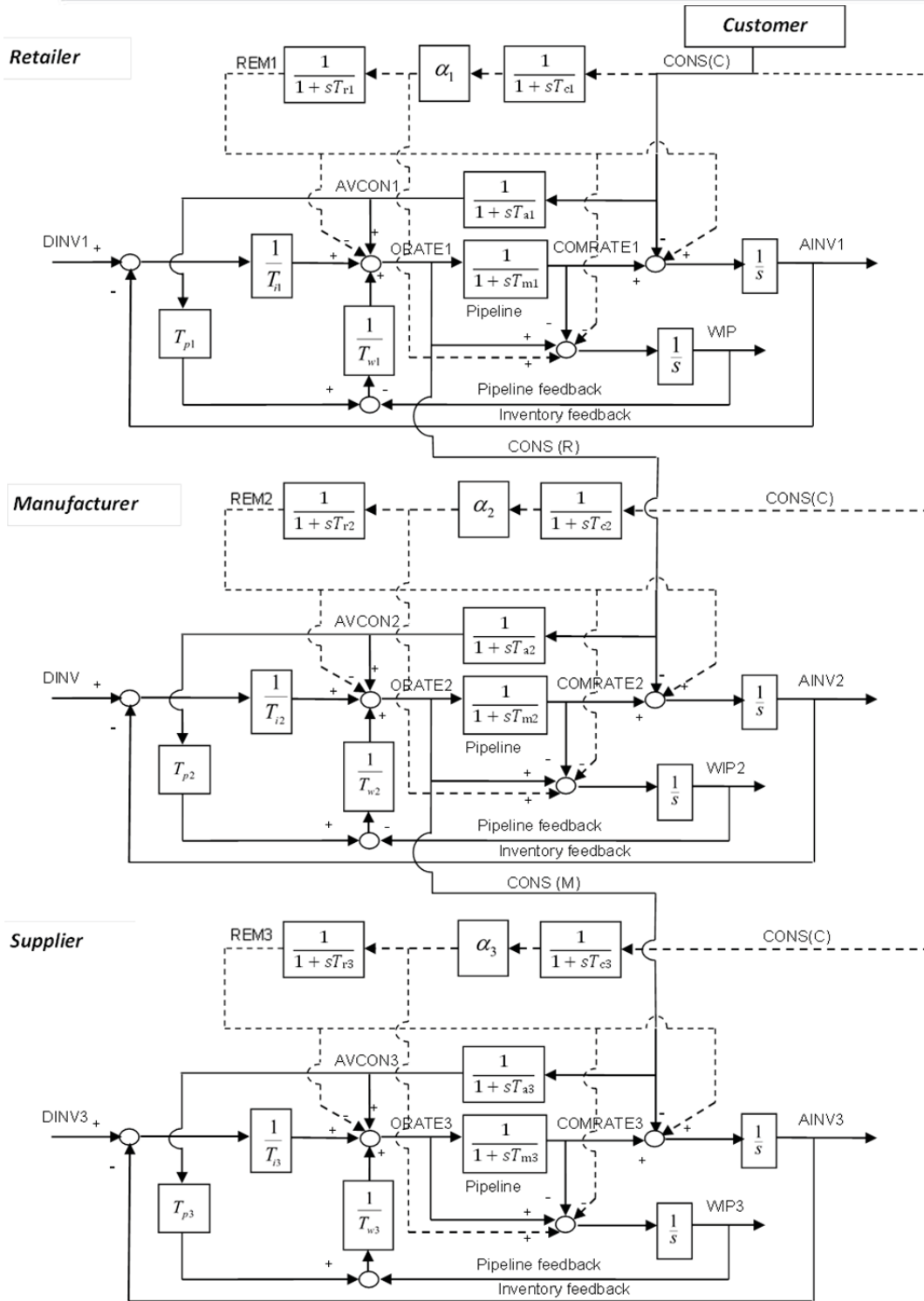
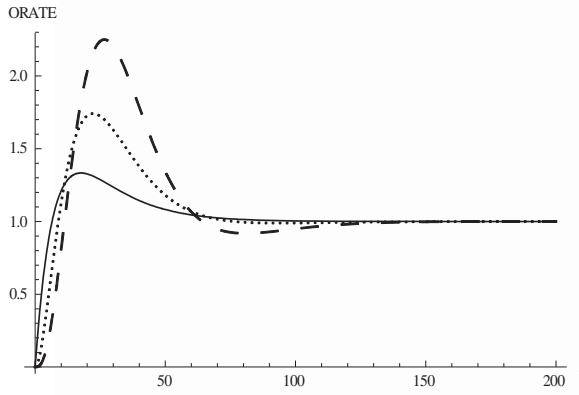

Figure 2. Block diagram of a three-echelon CLSC

Scenario 1:

$$\alpha_1 = \alpha_2 = \alpha_3$$

 $\alpha=0$ 

Scenario 2:

$$\alpha_1 = \alpha, \alpha_2 = \alpha/2, \alpha_3 = \alpha/3$$

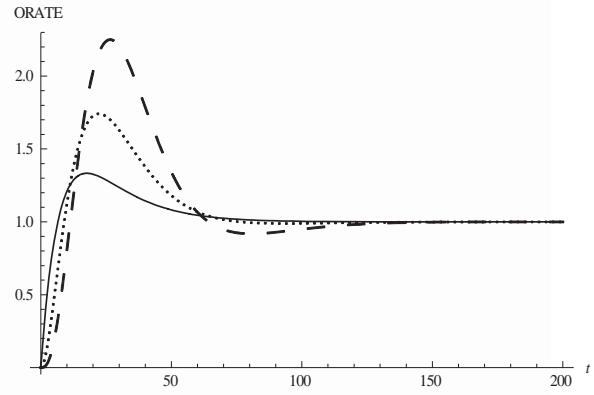
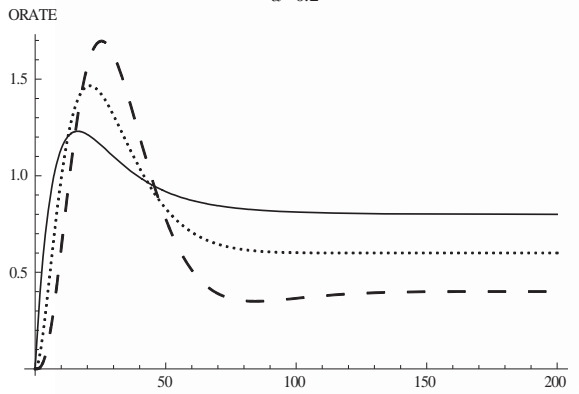
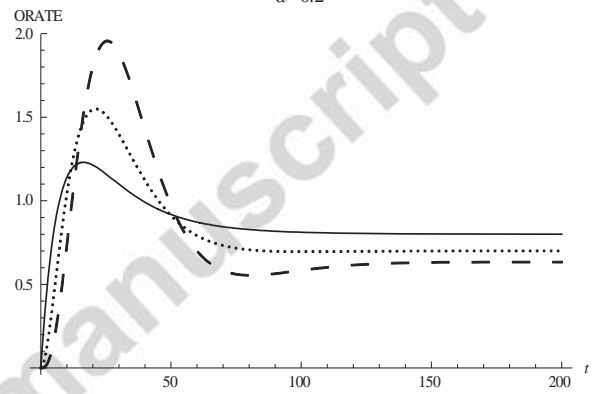
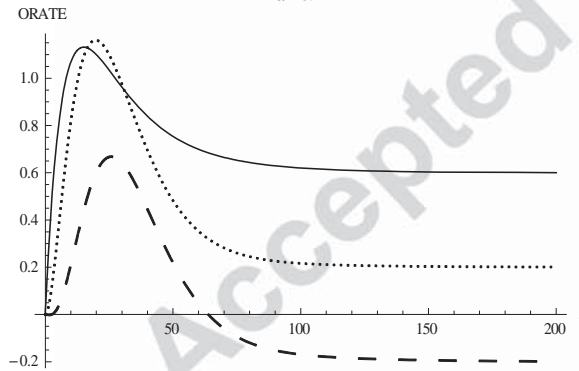
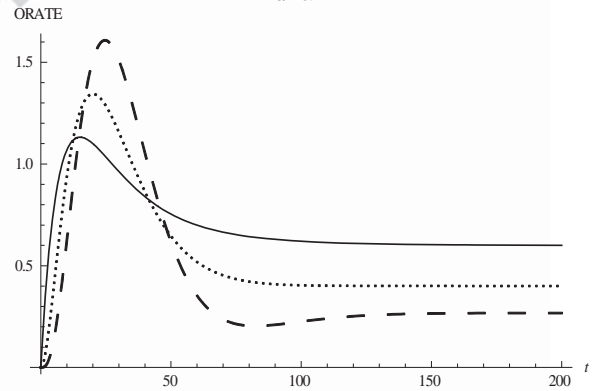
 $\alpha=0$  $\alpha=0.2$  $\alpha=0.2$  $\alpha=0.4$  $\alpha=0.4$ 

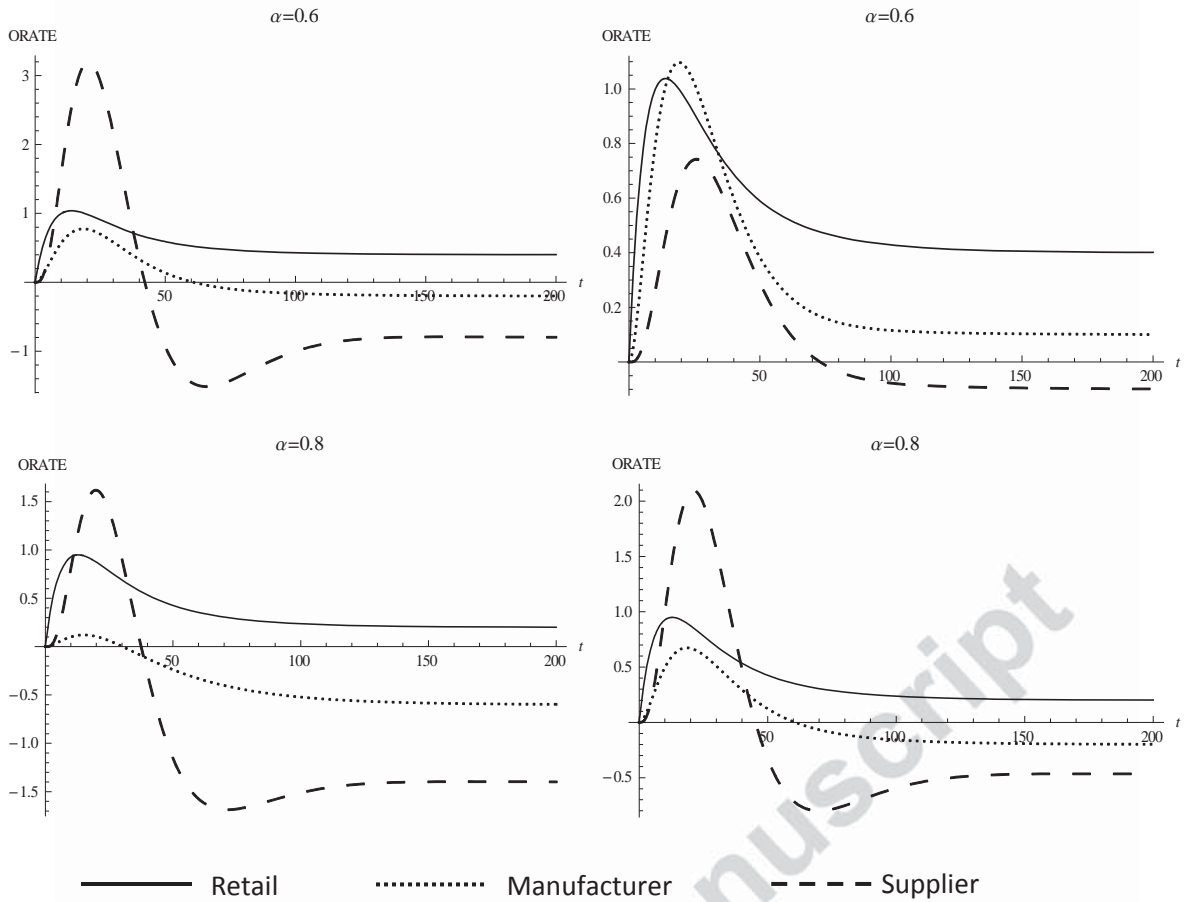
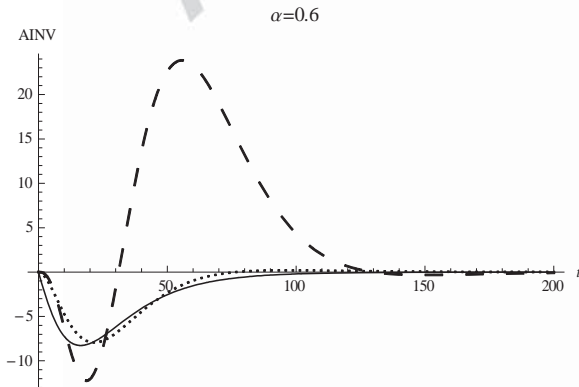
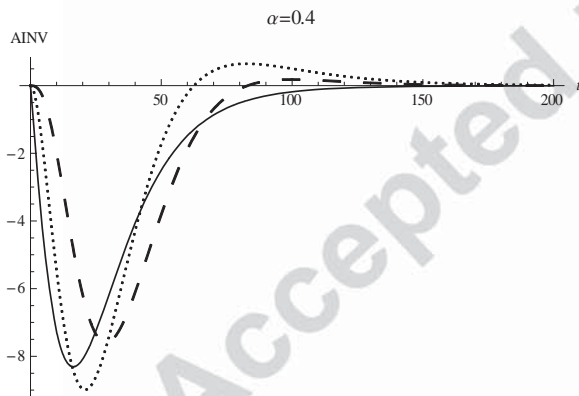
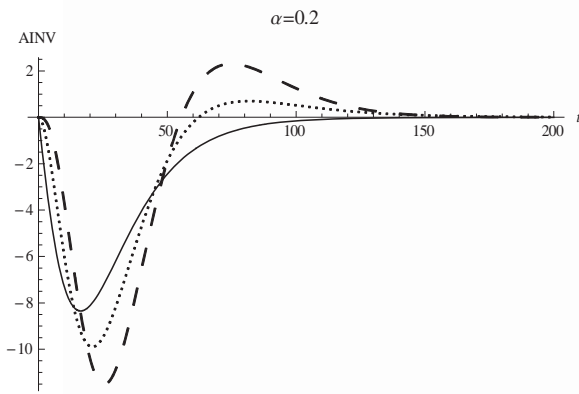
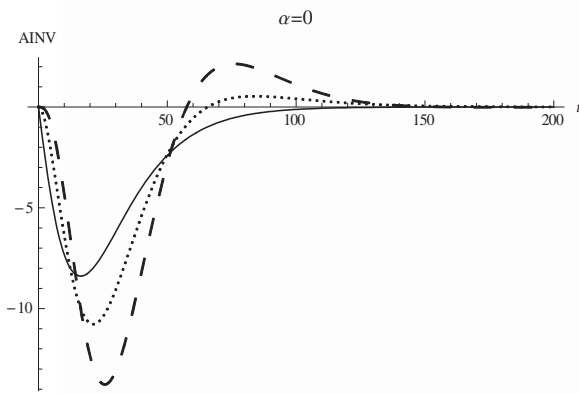

Figure 3. The impact of return yield  $\alpha_j$  on ORATE

$$T_i = 8, T_m = 8, T_w = 8, T_a = 16, T_c = 32, T_r = 4$$

Scenario 1:

$$\alpha_1 = \alpha_2 = \alpha_3$$



Scenario 2:

$$\alpha_1 = \alpha, \alpha_2 = \alpha/2, \alpha_3 = \alpha/3$$

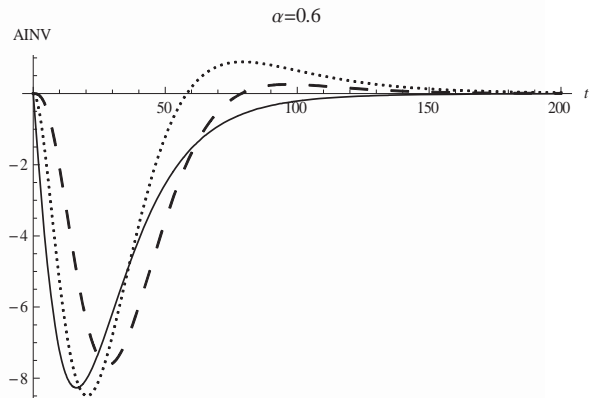
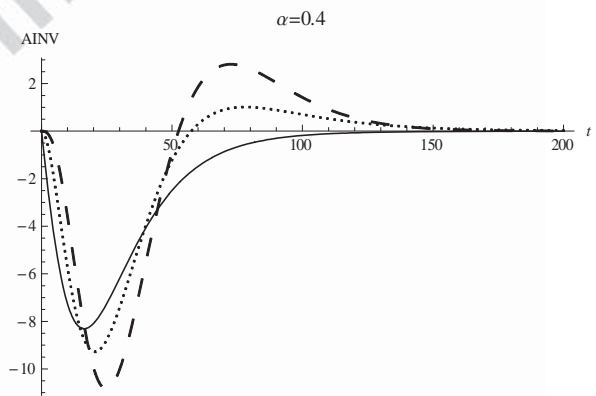
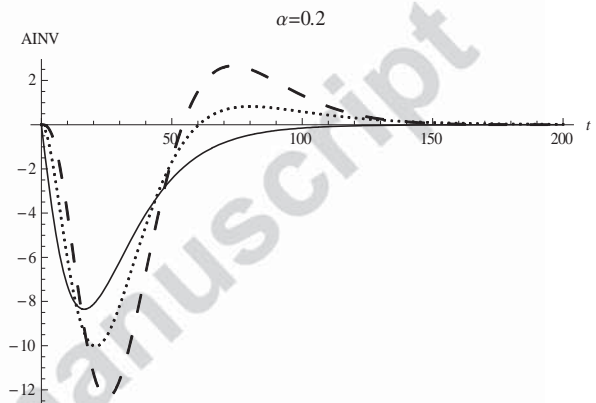
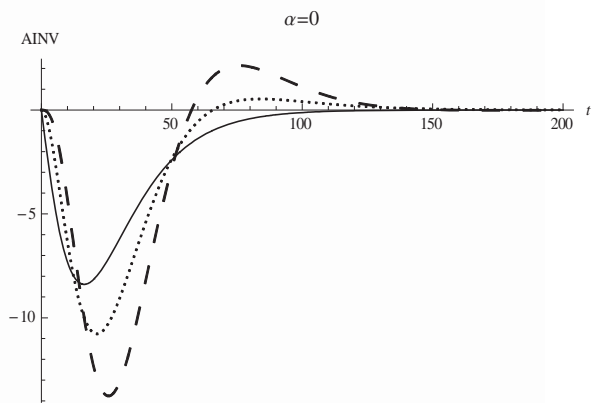

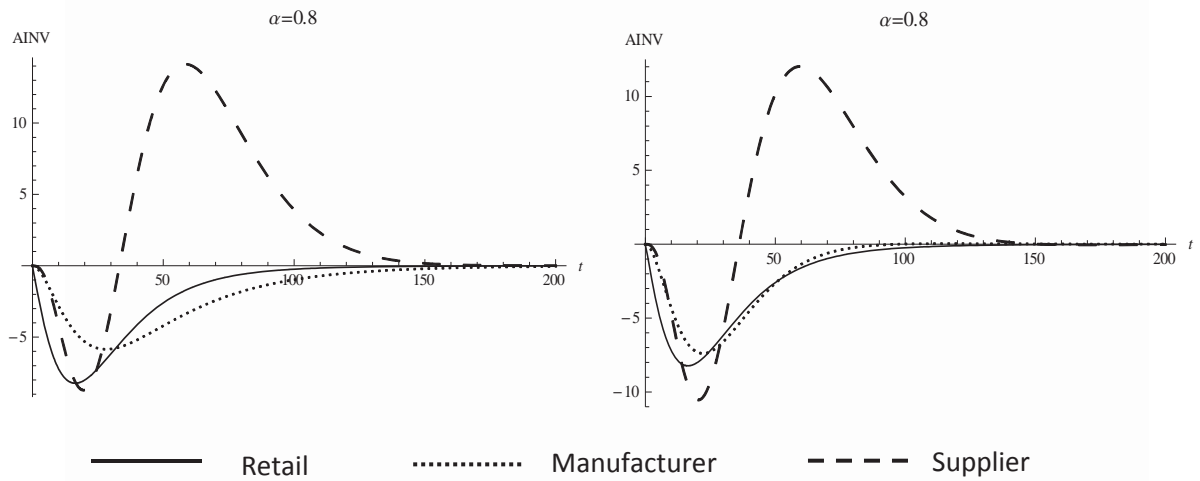
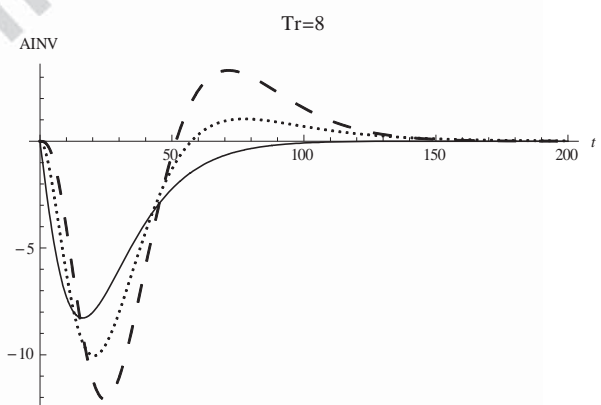
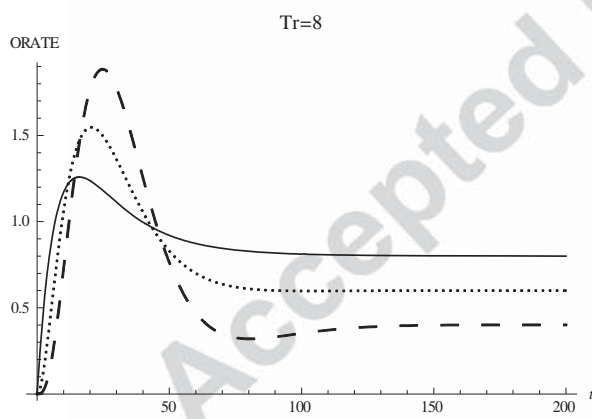
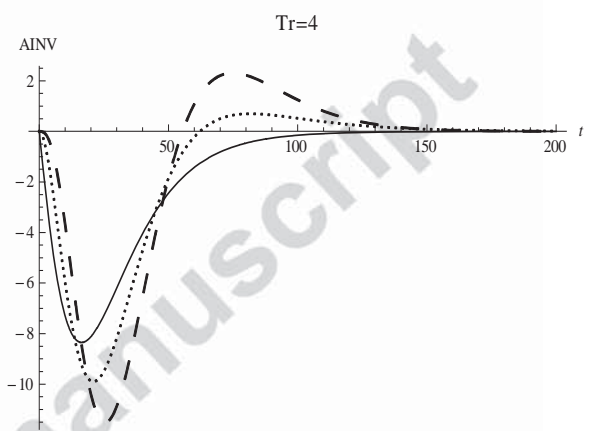
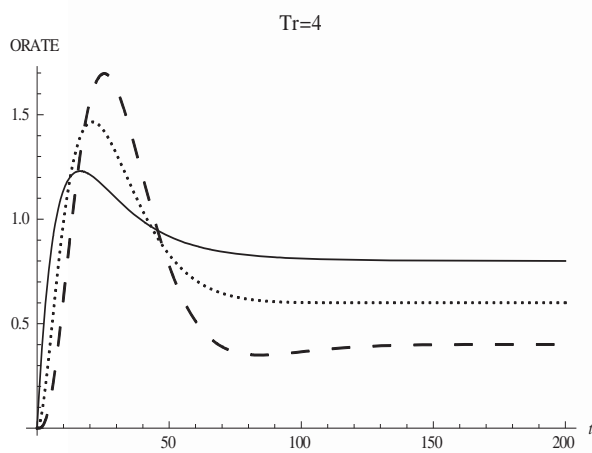
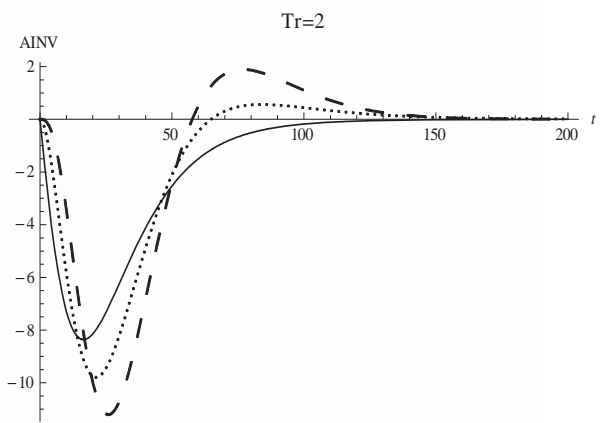
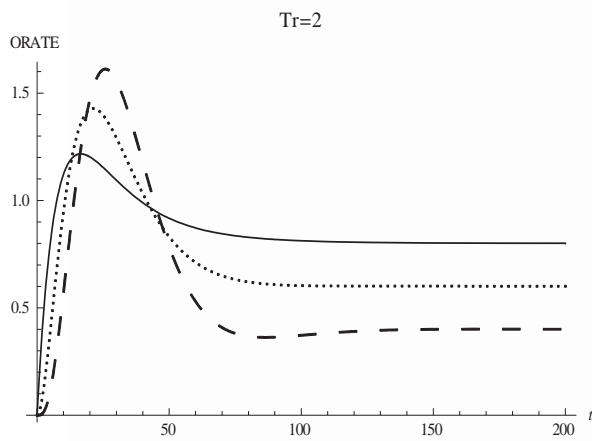

Figure 4. The impact of return yield  $\alpha_j$  on AINV

$$T_i = 8, T_m = 8, T_w = 8, T_a = 16, T_c = 32, T_r = 4$$

Accepted manuscript





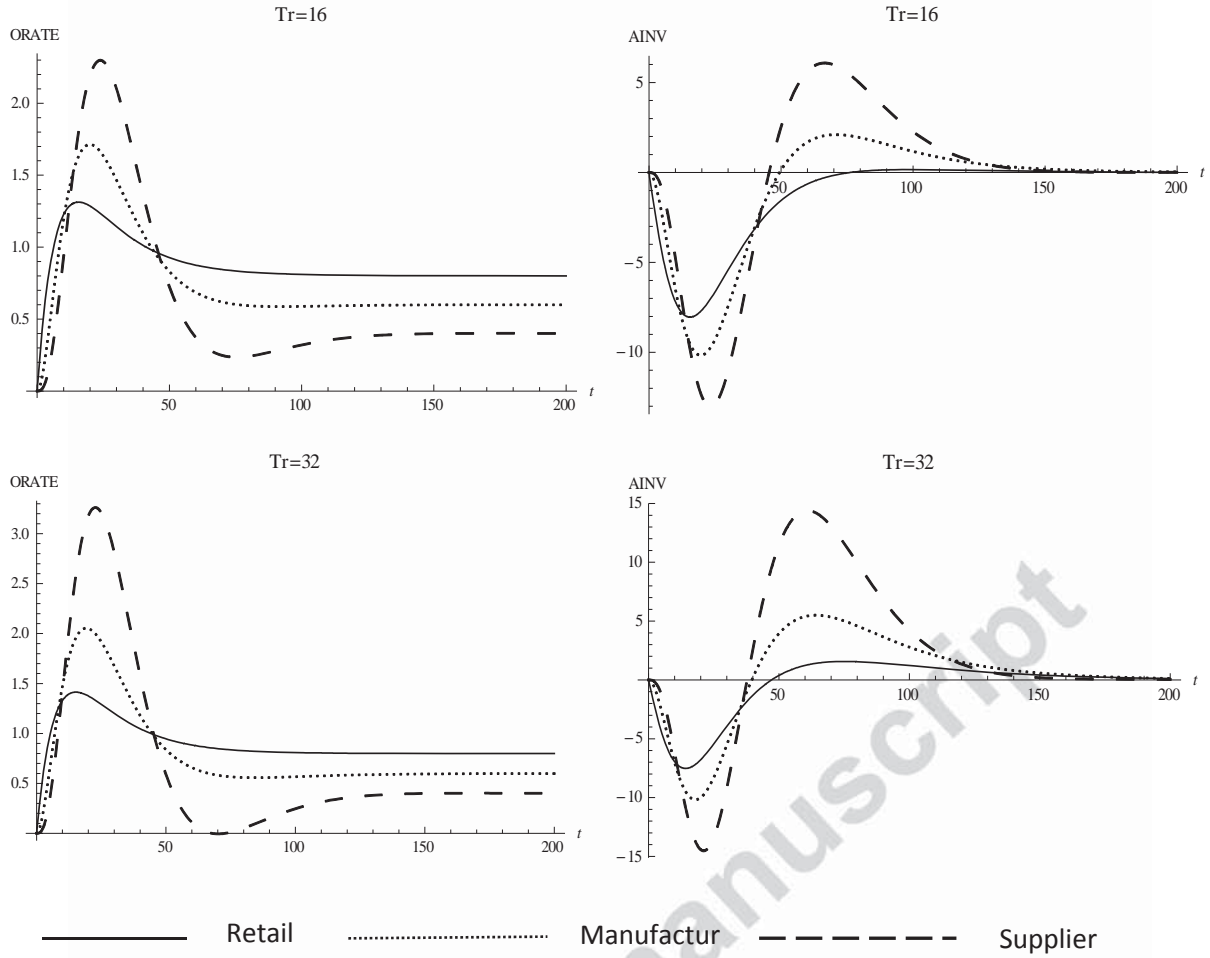
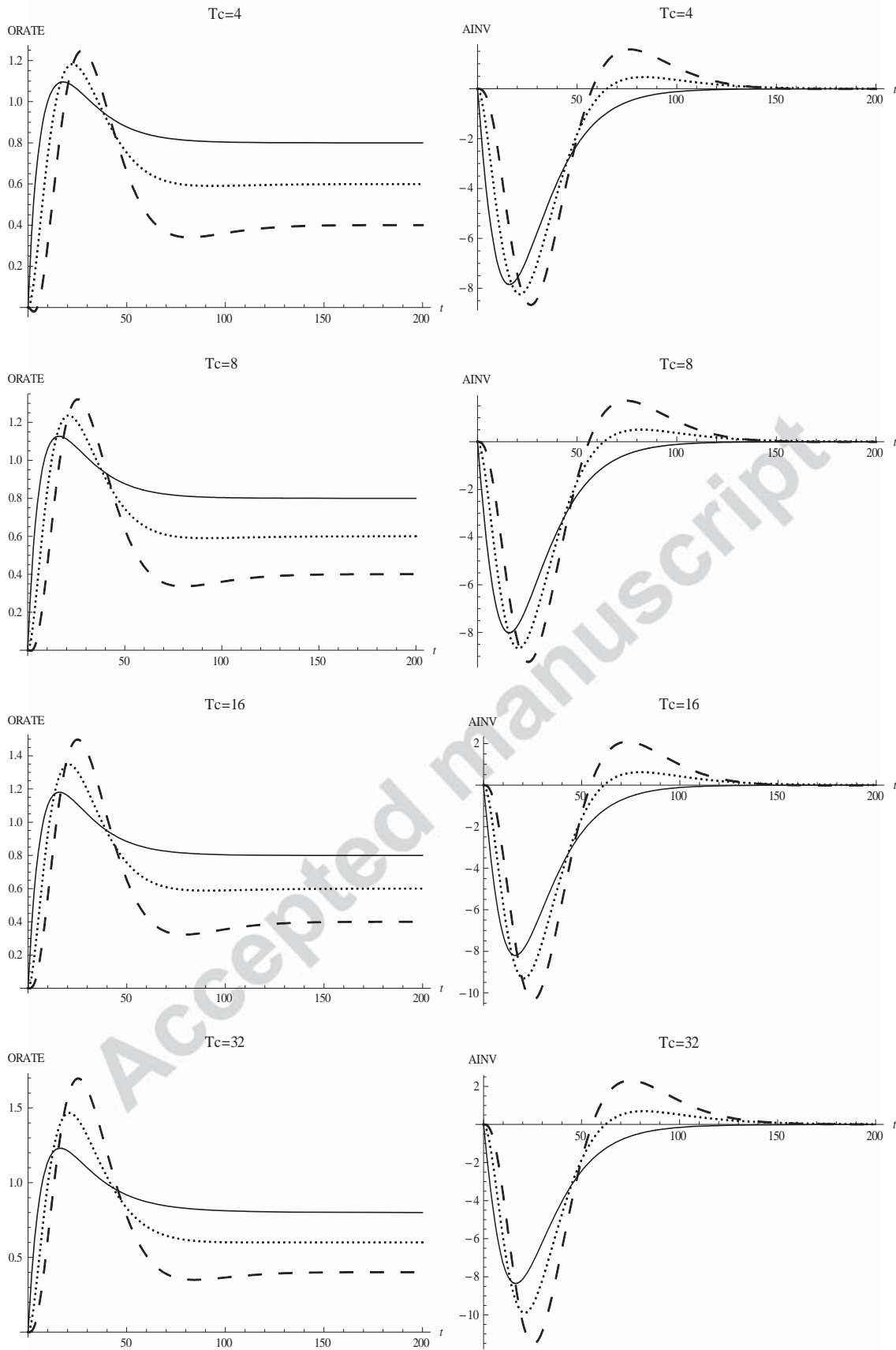

Figure 5. The impact of remanufacturing lead time  $T_r$

$$T_i = 8, T_m = 8, T_w = 8, T_a = 16, T_c = 32, \alpha = 0.2, T_r = T_{r1} = T_{r2} = T_{r3}$$



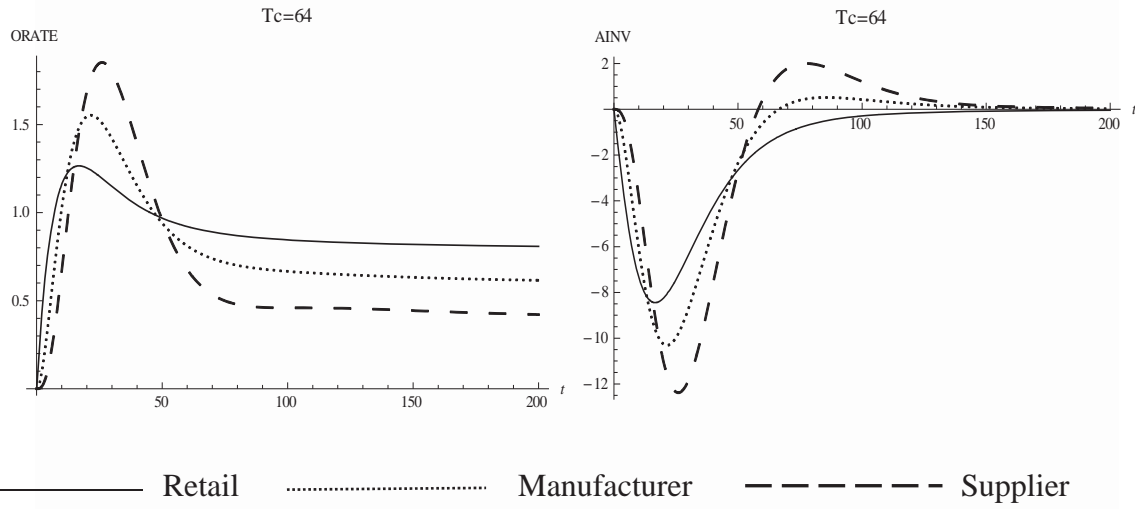
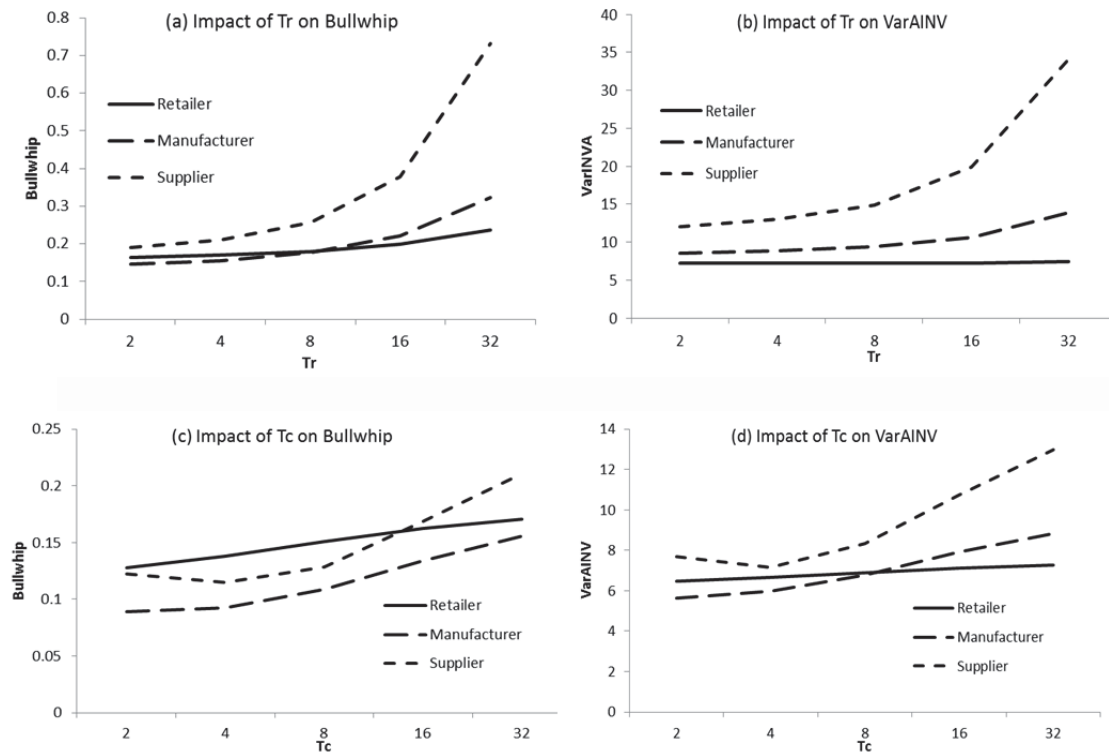

Figure 6. The impact of product consumption lead time  $T_c$   
 $T_i = 8, T_m = 8, T_w = 8, T_a = 16, T_c = T_{c1} = T_{c2} = T_{c3}, T_r = 4, \alpha = 0.2$



$$\alpha = 0.2; T_a = 16; T_i = 8; T_m = 8; \text{ either } T_r = 4 \text{ or } T_c = 32..$$

Figure 7. The impact of lead times of  $T_r$  and  $T_c$