

Shear design of high strength concrete beams with combination of links and horizontal web steel

J. Motamed¹, A.M. Alani² and A. Al-Hussaini³

University of Greenwich; University of Westminster

The existing recommendations in the Eurocode 2 and British Code of Practice for the shear design of beams are derived from research conducted essentially on normal strength concrete (NSC) with cube strengths up to 50 MPa, and it was found that the shear strengths of high strength concrete (HSC) members made with limestone aggregate are below characteristic resistances of identical normal strength concrete (NSC). The experimental tests by Kuchma, Vegh, Simionopoulos, Stanik and Collins have shown that significant differences exist in the angle of crack of shear failure of NSC and HSC.

The paper presents data from five beams tested by the first author which demonstrate that HSC with limestone aggregate has a reduced shear strength compared to NSC made with gravel exhibiting a gap in knowledge in the design approach to shear resistance of HSC beams.

Previous investigations have suggested that horizontal web steel can contribute to the overall shear resistance of a reinforced concrete member in conjunction with the other constituents, concrete, tension and shear steel. The paper also presents data from tests on eleven beams tested by the first author which show that shear resistance of HSC beams are highly dependent on dowel action resulting from horizontal web bars (HWB) positioned at the centre of the depth of the beam. Past attempts to quantify this dowel action are investigated and an improved design rule is proposed.

Notation

a	shear span from the centre of a point load to the centre of a support (mm)	S	spacing of links along the beam length (mm)
A_b	area of cross-section of horizontal web steel (mm ²)	V_{bu}	contribution of central bars to V_u (kN)
A_{st}	amount of tension steel (mm ²)	V_{calc}	calculated ultimate shear strength (kN)
A_{sv}	area of cross-section of a link (mm ²)	V_{col}	horizontal shear force across the column (N)
b	breadth of the beam (mm)	V_{cu}	contribution of concrete to V_u (kN)
b_n	net breadth of the beam at level of dowels reinforcement (mm)	V_{du}	dowel force (N)
b_w	web width of the beam (mm)	V_{dw}	strut formed by HWB dowel action to resist shear in direction of shear crack (N)
d	effective depth of the cross-section (mm)	V_{dwx}	strut from HWB dowel action to resist shear in horizontal direction at shear crack (N)
d_b	diameter of each HWB (mm)	V_{dwy}	strut from HWB dowel action to resist shear in vertical direction at shear crack (N)
D_{cr1}	dowel force in a single HWB (N)	V_{lu}	contribution of links to V_u (kN)
f_c	cylinder compression strength of concrete (N/mm ²)	$V_{Rd,c}$	calculated design shear resistance of a member without shear reinforcement (N)
f_{ct}	indirect tensile strength (N/mm ²)	V_{Rk}	calculated characteristic shear resistance (N)
f_{cu}	cube compression strength of concrete (N/mm ²)	$V_{Rk,c}$	calculated characteristic shear resistance of a member without shear reinforcement (N)
f_{yl}	yield for longitudinal reinforcement (N/mm ²)	V_{test}	measured ultimate shear strength (kN)
f_{yv}	yield strength of stirrups reinforcement (N/mm ²)	V_u	experimental ultimate shear resistance (kN)
f_y	yield stress of reinforcement (N/mm ²)	Z	flexural lever arm (mm)
I	moment of inertia of the structure from transformed section (mm ⁴)	σ_{be}	design bearing stress (N/mm ²)
J_v	moment of inertia of dowel bars + concrete cover directly below bars. (mm ⁴)	ρ_b	ratio of horizontal web reinforcement (A_b/bd)
M_{dw}	dowel moment resisted by HWB in the shear span (Nmm)	ρ_1	ratio of tension reinforcement (A_s/bd)
n	number of dowel bars	ρ'_1	ratio of compression reinforcement (A'_s/bd)
		ρ_w	ratio of web reinforcement (vertical stirrups)

1 Department of Civil Engineering, University of Greenwich

2 Department of Civil Engineering, University of Greenwich

3 School of Architecture and the Built Environment, University of Westminster

Introduction

A significant number of experimental tests have been carried out over the last 50 years to investigate the influence of dowel action on the shear behaviour of reinforced concrete (RC) beams. Morsch referred to the dowel action of longitudinal reinforcement on many occasions early in the last century (Morsch, 1902). However, dowel action is primarily dependent on the tensile strength of the concrete, and increase in the dowel capacity depends on the increase in the strength of the concrete and vertical crack displacement, therefore an appreciable dowel force develops only towards the ultimate load when shear cracks are actually opening, Figure 1.

When designing for shear resistance using Eurocode 2 or BS8110, the characteristic shear resistance of a slender rectangular section reinforced concrete beam can be assessed by applying the following expressions:

EC2 without shear stirrups is

$$V_{Rk,c} = 0.18(100f_c \cdot \rho_i)^{\frac{1}{3}} \cdot \left(1 + \sqrt{\frac{200}{d}}\right) \cdot bd \quad (1)$$

BS8110 without shear stirrups

$$V_{Rk,c} = 0.27(100f_c \cdot \rho_i)^{\frac{1}{3}} \cdot \left(\frac{d}{400}\right)^{\frac{1}{4}} \cdot bd \quad (2)$$

When shear stirrups are present the BS8110 expression changes to

$$V_{Rk} = 0.27(100f_c \cdot \rho_i)^{\frac{1}{3}} \cdot \left(\frac{d}{400}\right)^{\frac{1}{4}} \cdot bd + \rho_w \cdot f_{yv} \cdot bd \quad (3)$$

Equations 1 to 3 are in N and mm units. Coefficient 0.18 in equation 1 is recommended but may be modified in National Annexes. In EC2, there is a limit of $f_c \leq 90 \text{ N/mm}^2$.

In present UK recommendations, BS 8110 restricts concrete f_{cu} strength to a value of 40 N/mm^2 for equations 2 and 3 and the Concrete Society's recommendations of 1998 restricted concrete strength to 100 N/mm^2 but this was amended reduced to 60 N/mm^2 in 2004, motivated in part by this research work.

At the characteristic level the EC2 resistance in equation 1 is slightly above that of BS8110 in equation 2. However, EC2 applies a partial safety factor of 1.5 to obtain design resistances, while the BS8110 factor is only 1.25. When designing to EC2, shear resistances are about 10% below those from BS8110 equation (2), although the difference is in effect reduced by the UK's only just higher load factors.

Equations 1, 2 and 3 are derived from research conducted essentially on normal strength concrete (NSC) with cube strengths of up to 50 Mpa and it is demonstrated that they are not applicable to high strength concrete (HSC). The development of dowel action in beams is a result of the longitudinal reinforcement taking some shear force in a crack, initiated by the vertical movement of two opposite crack surfaces. On the contact area of the concrete and the steel there are stresses which are perpendicular to the longitudinal reinforcement. Dowel failure occurs with the formation of a crack next to the steel bar and in the same direction as the bar.

The shear force in the bar increases proportionally to the

vertical crack displacement, therefore an appreciable dowel force develops only towards the ultimate load when shear cracks are actually opening.

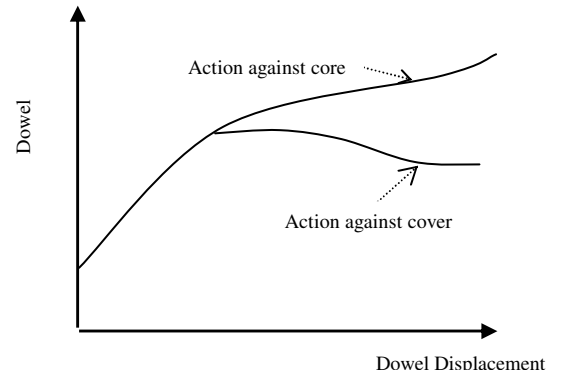

Figure 1: Dowel load in relation to the action against core concrete as compared to the cover

Source: Baumann, 1968

In practice, dowel action occurs in reinforced concrete at both flexural and shear cracks and the forces against the cover are decisive for the failure of the dowel action, therefore an appreciable dowel force develops only towards the ultimate load, when shear cracks are actually opening. Dowel bars may also act against the core of concrete resulting in a bending of the bar and local crushing of the concrete alternatively, may cause splitting in the plane of the bar if the cover is small.

Horizontal web bars (HWB) increase the shear strength of a beam by developing improved dowel action when they are placed close to the centre of the depth of the beam or in the beam core and are considered effective for design purposes. There is a need to include a provision for the direct contribution of HWB to shear resistance when designing for shear.

Experimental investigation

The size and the length of the test specimens were chosen to make the beams fail in shear ($a/d=3$) and to ensure that the specimens were sufficiently large to simulate real structural elements. Figures 2 to 4 to show the details of the eleven beams which were $150 \times 300 \text{ mm}$ in section with a span of 2.2m. For all beams the tension steel was 3T20 ($\rho_1 = 2.37\%$, $d=265 \text{ mm}$) and shear links were R6 at 200mm centres in the shear spans. Both NSC and HSC beams were tested without and with horizontal web steel of 2T12, 2T20 and 2T25. The beam notation is explained in Table 1.

Tests were carried out on three specimens representing the steel in the links and the average value f_{yv} was 250 N/mm^2 . The reinforcement used for the top, bottom and horizontal web steel was high yield, hot rolled deformed bars with a guaranteed yield value f_{yl} of 460 N/mm^2 . Details of concrete strengths, f_{cu} and f_{sp} are given in Table 1. In the concrete mix design, Rapid Hardening Portland cement was used together with 20mm gravel for NSC and 10mm limestone for HSC. f_{cu} was around 44 N/mm^2 for the NSC and 111 N/mm^2 for the HSC.

Table 1: Data for the beams tested by the first author at the University of Westminster

Beam No	Top Steel	Stirrup	Space (mm)	Horizontal web bar (HWB)	Cube Strength (f_{cu}) N/mm ²	Splitting strength (f_{sp}) N/mm ²	Ultimate load ($2V_u$) kN
NSC1	2T20	2R6	200	0	43.2	2.98	160
NSC2	2T20	2R6	200	2T12	41.0	3.01	203
NSC3	2T20	2R6	200	2T20	47.7	3.22	200
NSC4	2T20	2R6	200	2T25	43.3	2.97	210
HSC1-1	2R6	2R6	200	0	109.0	4.21	140
HSC1-2	2R6	2R6	200	0	101.2	-	143.3
HSC1-3	2R6	2R6	200	0	106.6	-	160.0
HSC2	2R6	2R6	200	2T12	109.3	5.20	265
HSC3	2R6	2R6	200	2T20	112.5	4.34	280
HSC4	2R6	2R6	200	2T25	112.5	4.34	300
BJ-2	2T20	2R6	200	0	118.1	4.3	142

Notes: f_{yv} (stirrup) = 250 N/mm². f_{yt} (longitudinal) 460 N/mm².

* Flexure reinforcement started to yield at failure only for the HSC beams with HWB

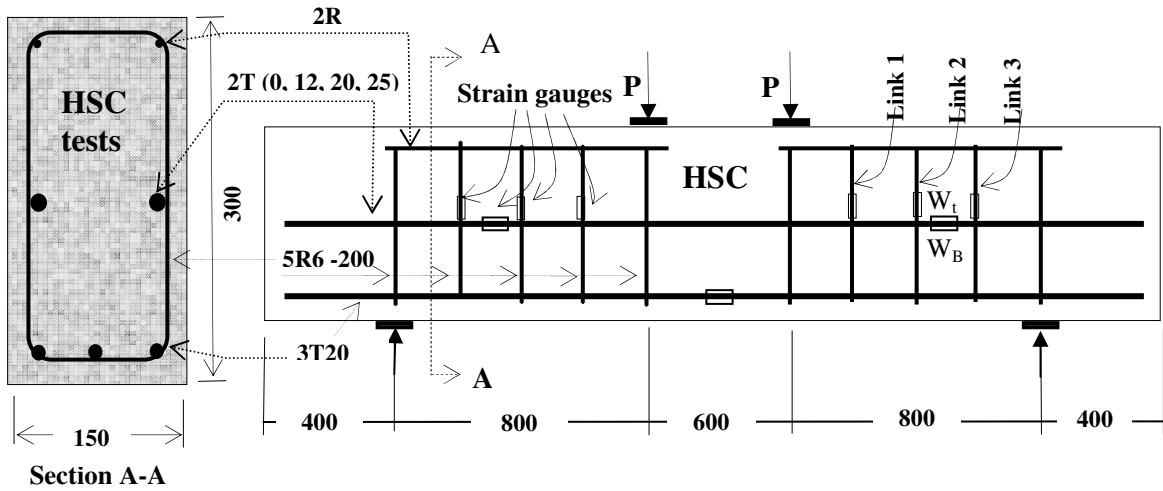

Figure 2: HSC beams with and without HWB, with strain gauges with $a/d=3.02$

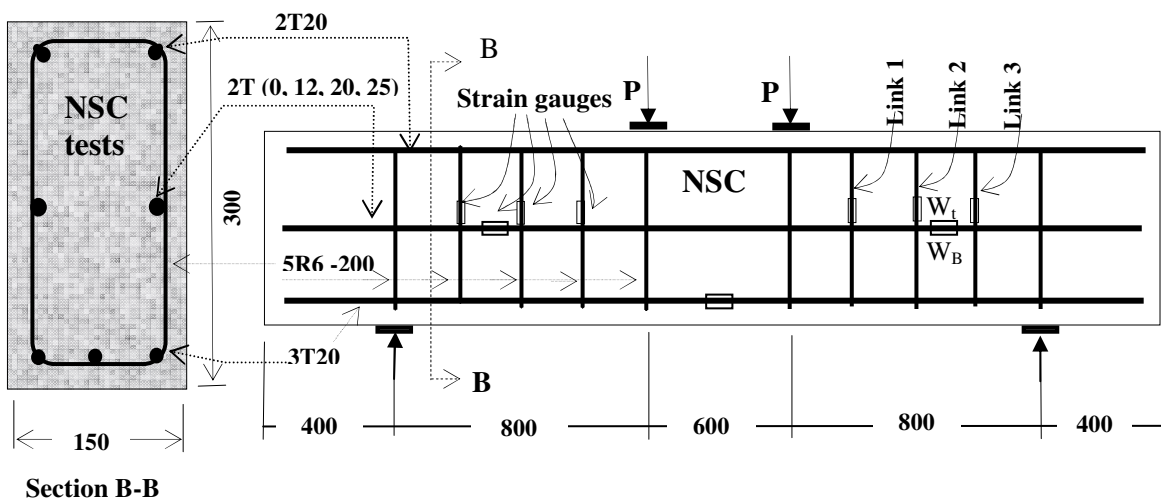

Figure 3: NSC beams with and without HWB, with strain gauges with $a/d=3.02$

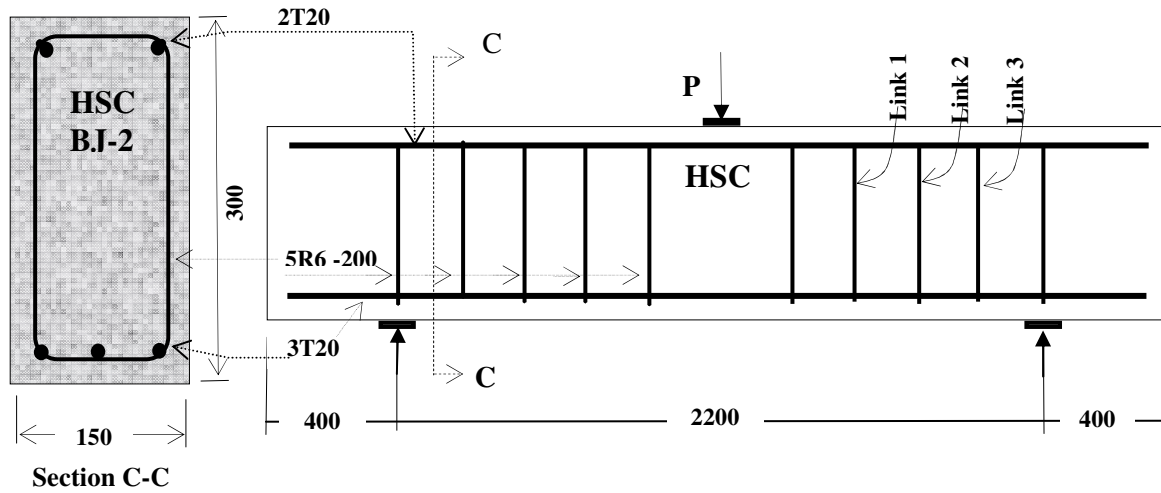

Figure 4: BJ-2 is HSC beam with stirrup and $a/d=4.15$

For HSC, the water: cement ratio was kept at 0.29 with the addition of admixtures. The beam specimens, 150 mm BS cubes for NSC and 100mm BS cubes for HSC, were cured in 28 days. The compressive strength tests were conducted on the same days as the beam tests. The concrete for all the beams was compacted using an immersion mechanical poker vibrator.

Beam test procedures: At each load increment, the vertical deflection at mid-span as well as the strains in the links, horizontal web bars and tensile reinforcing bars, were recorded. The development of cracks was also observed and recorded.

Test results and discussions

A summary of the test specimens details and results is given in Table 1. The discussion of this part is presented in seven sections: (a) Shear failure loads; (b) Load-deflection behaviour; (c) Crack propagation d) Shear resistance of HSC beams compared to NSC; (e) Load-strain behaviour; f) Tension reinforcement strain behaviour.

(a) *Shear failure loads.* The first HSC1 failure load of 130 kN ($f_{cu} = 109 \text{ N/mm}^2$) appeared low, the first result was compared with the second HSC1 failure load of 140 kN ($f_{cu} = 101.2 \text{ N/mm}^2$) and third failure load of 160 kN ($f_{cu}=106.6 \text{ N/mm}^2$). The average ultimate load carried by these three similar HSC1 beams was 143.3 kN ($f_{cu}=105.6 \text{ N/mm}^2$) as compared to ultimate load of beam NSC1 which was 160 kN ($f_{cu}=43.2 \text{ N/mm}^2$). The links were similar in the two and neither contained any horizontal web steel. NSC1 did have 1.55% of compression reinforcement which was not present in HSC1. The inclination of the critical shear crack was much steeper in HSC1 at about 50° as compared with approximately 35° in NSC1.

The surprising reduction of shear resistance with increasing concrete strength found for beams NSC1 and HSC1 was reversed when horizontal web steel was provided. With two 25mm web bars in both, the ultimate loads for HSC4 ($f_{cu}=112.5 \text{ N/mm}^2$) and NSC4 ($f_{cu}=43.3 \text{ N/mm}^2$) were 300 kN and 210 kN respectively. The major increase of shear

strength for the HSC beams occurred between HSC1 (without horizontal web bars) and HSC2 (2T12) with ultimate loads of 130 kN and 265 kN. With increasing the HWB, HSC3 (2T20) carried 280 kN and HSC4 (2T25) took 300kN.

With ordinary concrete the influence of horizontal bars was modest; NSC1 (no web bars)-160kN, NSC2 (2T12)-203kN, NSC3 (2T20)- 200kN and NSC4 (2T25)-210kN.

The results for the four high strength concrete beams with horizontal web steel demonstrated that no limit to improvement in shear resistance as the result of increasing the area of horizontal web reinforcement was reached. When the diameter of the web bars was increased from 20 to 25mm a further 7% improvement was recorded.

(b) *Load-deflection behaviour.* Mid-span deflections were measured by a single gauge mounted from the laboratory floor and included any settlements of the supports.

The deflection of beam HSC1 was fairly similar to that of NSC1. Both beams were without any horizontal web reinforcement the 1.55% of compression reinforcement, which was present in NSC1, reduced its deflection but the higher strength and elastic modulus of the concrete in HSC1 with no compression steel counter-weighted the compression steel in NSC1. The deflection of beam NSC1 was greater than for NSC4 (2T25) at equal loads and NSC1's deflection near failure was the greater.

The deflections of HSC2, HSC3 and HSC4 did not change by more than 15% as the area of horizontal web steel was increased in beams of high strength concrete.

(c) *Crack propagation.* At loads of 40 to 60 kN, small flexural cracks appeared, at the bottom surface in the region of constant bending moment. As the load was increased new flexural cracks appeared in the shear spans spreading from the load application sections towards the supports and the flexural cracks in the shear spans tended to become somewhat inclined. This was followed by the sudden occurrence of a wide shear crack in one of the shear spans, which lead to failure. A crack angle was defined as the angle between a tangent to the crack at the centre of the depth of the beam and its x-axis. The angle of the failure crack for the higher strength concrete beam HSC1 was about 50° compared to the 35° for

normal beam NSC1.

Beams HSC2, HSC3 and HSC4 had respective angles of cracks of about 43°, 45° and 42° compared to beams NSC2, NSC3 and NSC4 with angles of cracks 28°, 27° and 27°.

HSC1 and NSC2 had dowel cracks at the level of the bottom steel. These cracks were formed at 120kN (92% V_u) and 140kN(64% V_u). NSC3 and HSC4 may possibly have had dowel cracks in mid-web formed at 190kN (86% V_u) and 230kN (77% V_u). HSC3 and NSC4 developed web dowel cracks at 210kN (75% V_u) and 200kN (95% V_u).

(d) *Shear resistance of HSC beams compared to NSC.* A group of tests in Table 2 suggests a possible problem with high strength limestone aggregate concrete. When considering these results one needs to bear in mind that the amount of shear reinforcement used in the HSC beams was below the minima of both EC2 and the Concrete Society recommendations, which are $\rho_w f_y \geq 0.08$ and $\rho_w f_y \geq 0.039 f_{cu}^{2/3}$. Even so, it is somewhat surprising that the ratio of the ultimate shear to the characteristic resistance, calculated by the BS equation without a limit on f_{cu} and ignoring the requirement on $\rho_w f_y$, was as low as 0.69 with beam HSC1-1.

The ultimate strengths of three of the four HSC beams (HSC1-1, HSC1-2 & BJ-2) were below both that of a reference beam NSC1 with gravel aggregate of normal strength value f_{cu} and the resistances were calculated ignoring the stirrups.

depends on the roughness of the crack surfaces and the widths of the cracks.

The review (Regan et al, 2005) of differences in the behaviour of dense concrete made with different aggregates based on several experiments (Taylor, 1970; KaWar,1980; Walraven, 1979; Motamed, 1997) on aggregate interlock concluded that the shear transfer strength of specimens made with limestone aggregate failed to increase with increasing concrete strength. The same trend seems to occur to a lesser degree in other aggregates and members without shear reinforcement are likely to be even more affected.

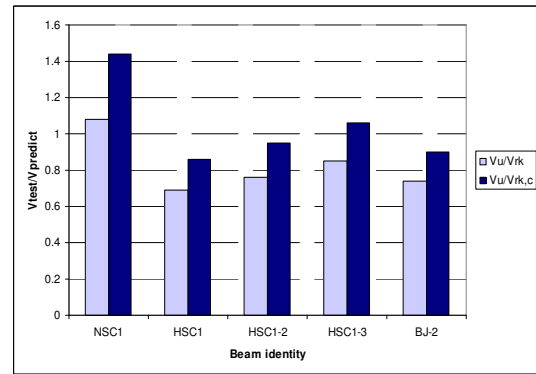

Figure 5: Comparison of experimental test results with BS8110 design rule, equations 2 and 3

Table 2: Comparison of tests results of beams from Table 1 with BS8110 equations 2 and 3.

Beam No.	ρ_i %	a/d	f_c (N/mm ²)	V_u (kN)	V_{rkc} (kN)	V_u/V_{Rk} equ (3)	$V_u/V_{Rk,c}$ equ (2)
NSC1	1.58	3.02	34.6	80	51.6	1.08	1.44
HSC1-1	0.14	3.02	94	65	71.9	0.69	0.86
HSC1-2	0.14	3.02	86.2	70	69.9	0.76	0.95
HSC1-3	0.14	3.02	91.6	80	71.3	0.85	1.06
BJ-2	1.58	4.15	103.1	71	74.2	0.74	0.90

Notes: Details of beams are in Table 1.

In Table 2, the ratio of empirical values of ultimate shear resistance is compared to the predicted value from BS8110 for beams without HWB. All beams have stirrups, $\rho_w f_{yw} = 0.47$ N/mm² or $V_s = 18.72$ kN.

Comparing the mean shear failure load V_u of 71.7 kN for HSC1, HSC1-2 and HSC1-3 with NSC1 which had a shear failure load V_u of 80 kN, HSC beams have on average 11.6% less shear resistance compared to equivalent NSC beams.

It was found that the shear strengths of HSC members are often below characteristic resistances calculated according to EC2 and BS8110.

In reinforced concrete members without shear reinforcement, shear resistance is mainly affected by the transfer of shear forces across cracks of which a large part of the applied shear is carried across flexural cracks. The force transfer across early 45° cracks develops a resistance greater than those anticipated for 45° truss models when shear steel is present. The magnitude of the shear transferred across a crack

(e) *Load-strain behaviour.* A comparison can be made between strains in links for the beams HSC4 and NSC4. Both beams had 2T25 horizontal web reinforcement. In the beam NSC4 links 1, 2 and 3 yielded at 200 kN. Whereas, in HSC4 links 2 and 3 yielded at 200 kN and link 1 yielded at about 230 kN. This shows that the difference between HSC and NSC is quite small at the stage of stirrup yield-nothing like so big as the difference in failure load. Beam HSC4 continued to sustain load for an increment of 100 kN after links 2&3 yielded and an increment of 70 kN after link 1 yielded. The horizontal web reinforcement (2T25) of HSC4 yielded at 270 kN, Figure 6(d).

One possible explanation is that the horizontal web reinforcement in beam HSC4 was stabilising arching. This resulted in yielding of the links and increased the forces in the main steel near supports. This tie effect of the tension steel continued until the tension reinforcement reached 90% of its yield strain at 300 kN when the beam failed, Figure 6 (d). In the beam NSC4 links 1,2 and 3 yielded at 200 kN.

In beam HSC1, link 2 yielded at about 100 kN and link 3 reached 80% of its yield at 110kN. Shear failure occurred with a crack positioned between links 2 and 3, when link 1 had not yet reached 40% of its yield, and the strain at mid-span of the tension steel had reached only 40% of its yield, Figure 7(d).

(f) *Tension reinforcement strain behaviour.* Past research (Rogowsky and MacGregor, 1986; Hejazi, 1997) has shown, however, that the HWB has little, if any, effect on the shear strength of NSC beams. This is due to the comparatively low crushing strength of NSC which crushes before reaching sufficient plasticity to bring the tension bar to yield. Similarly, as shown in Figure 6 (a, b & c) in NSC of $a/d=3.05$ with HWB and stirrups, the arching action does not develop enough to bring HWB or tension bar to yield (Motamed, 2010). Whereas Figure 6 (d, e& f) shows that HSC beams of $a/d=3.05$ with HWB have high enough concrete strength to bring the tension bar to yield.

In beam NSC4, cracks initiate as inclined tension cracks and at 160 kN inclined web cracks rapidly develop up to 200 kN. Strain on the bottom face of web bar W_b increases corresponding to readings on top face W_t until 160 kN loading, after which the bottom face W_b remains constant. In beam NSC3, inclined web cracks develop at 170 kN. Strain on W_b increases corresponding to readings on W_t up to 160 kN loading, after which W_b remains constant, Figure 6 (b). In beam NSC2, strain on W_b increases corresponding to readings on W_t until 130 kN loading, after which W_b remains constant, Figure 6(c).

(g) *Influence of dowel action on links at the centre of the shear span.* Strain fluctuation in the centre link for beams NSC1, NSC3, HSC1 and HSC3 is shown in Figure 7 (a & b). Beam NSC3 has a rate of increase in strain of 0.0042×10^{-3} per kN up to 140 kN, 0.0243×10^{-3} per kN from 140 kN to 160 kN, and 0.16×10^{-3} per kN up to 6.77×10^{-3} strain. It was recorded experimentally, Figure 7(d), that after HSC3 has passed its yield value of 1.3×10^{-3} several times over reaching 9.9×10^{-3} at 200 kN, a significant shear crack causes the centre link to yield but the dowel action from HWB resists the shear forces from 200 kN to 280 kN or the final 80kN (40%) loading.

For beam NSC3, the presence of HWB does not make much difference in strain on the centre link until 120 kN, Figure 7 (c). NSC1, which has no HWB, yields at 120 kN, Figure 7(a).

The experimental results for beams HSC1 and HSC3 show that after 120 kN as the strain in centre link of HSC1 reaches 1.8×10^{-3} , 138% of its yield value, the beam abruptly fails, whereas when HWB is present the strain in centre link remains as little as 0.17×10^{-3} , 13 % of its yield value, up to 180 kN loading. However, due to the formation of large shear cracks, the centre link reaches strain of 9.9×10^{-3} (760% of its yield) at 200 kN but at this stage the HWB resists the shear forces for another 80kN, or a further 40% increase in loading, Figure 7(f).

Proposal of an alternative design rule

The shear resistance of rectangular reinforced concrete beams with vertical stirrups can be assessed by the BS8110 equation (3).

In this code, upper limits of $\rho < 3\%$ and $f_{cu} < 40 \text{ N/mm}^2$ are imposed. One way of assessing the total shear resistance of a member with a single layer of horizontal web steel is to add its dowel resistance to the above V_{cu} .

Using Baumann's dowel cracking expression:

$$D_{cr1} = K.b_n.d_b.f_{cu}^{\frac{1}{3}} \quad (4)$$

Baumann's equation is based on the idea that; The bearing length is proportional to:

$$\sqrt[4]{\left(\frac{\text{Flexural stiffness of dowel}}{\text{Modulus of support}} \right)}$$

When there are n dowel bars then;

Flexural stiffness of total dowel = $n \times$ Stiffness of one bar.

The modulus of support ought to be practically independent of the number of bars. This suggests a change of Baumann's equation from equation (4) to:

$$D_{cr1} = K.b_n.d_b.\sqrt[4]{n}.f_{cu}^{\frac{1}{3}} \quad (5)$$

To check if the movements of cracks should be sufficient for the mobilisation of D_{cr} , reference was made to published measurements of vertical movements at flexural cracks that developed into shear cracks. It was clear that the movements are large enough for dowel resistance to be fully achieved as it is limited by the tensile strength of the concrete, and a movement of about 0.1 mm can adequately mobilise it.

Hence if D_{cr} is adequately mobilised, the suggested formulation for the shear strength of the beam with stirrups to BS8110 equation (3) with horizontal web reinforcement is;

$$V_{cu} = 0.27 (100f_{cu}.\rho_i)^{\frac{1}{3}} \cdot \left(\frac{d}{400} \right)^{\frac{1}{4}} .bd + A_{sv}.d \frac{f_{yv}}{s} + b_n.d_b.\sqrt[4]{n}.f_{cu}^{\frac{1}{3}} \quad (6)$$

The other proposal by Desai based on including dowel action in BS8110 equation (3) is;

$$V_{cu} = 0.27 (100f_c.\rho_i)^{\frac{1}{3}} \cdot \left(\frac{d}{400} \right)^{\frac{1}{4}} .bd (1 + 0.40 \rho_b) + A_{sv}.d \frac{f_{yv}}{s} \leq V_{max} \quad (7)$$

The maximum allowable shear from equation 7 is given as;

$$V_{max} = 1.4 \times 0.27 (100f_c.\rho)^{\frac{1}{3}} \cdot \left(\frac{d}{400} \right)^{\frac{1}{4}} .bd + A_{sv}.d \frac{f_{yv}}{s} \quad (8)$$

It is difficult to follow why the ratio of main reinforcement should affect the contribution of the web bars in equation 7. The upper limit in equation (8) is also hard to understand. For all the beams 6 mm diameter single links at 200 mm centres were used, therefore

$$V_{lu} = A_{sv} \cdot d \frac{f_{yv}}{s} \quad (9)$$

where $A_{sv} = 56.6 \text{ mm}^2$, $f_{yv} = 250 \text{ N/mm}^2$, $d = 270 \text{ mm}$ & $s = 200 \text{ mm}$
Hence $V_{lu} = 19.1 \text{ kN}$
where $100 A_s/bd = 2.33$, $d=265$, $b=150$. From the modified Baumann equation

$$V_{bu} = 1.64 b_n d_b \sqrt[4]{n} \cdot f^{\frac{1}{3}} \quad (10)$$

$$V_{bu} = 1.95 b_n d_b f^{\frac{1}{3}} \quad (\text{where } n=2 \text{ and } b_n = b-2d_b)$$

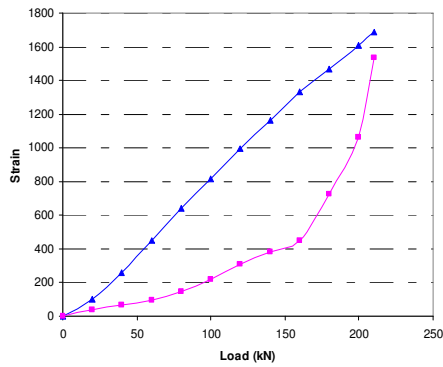

a) Beam NSC4, strain W_i on top of web bar (T25) and tension reinforcement (T20) not yielding.

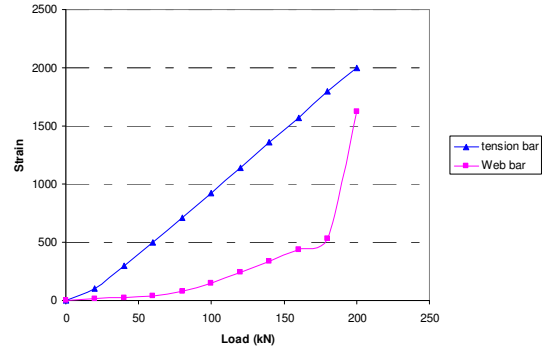

b) Beam NSC3, strain W_i on top of web bar (T20) and tension bar (T20) not yielding

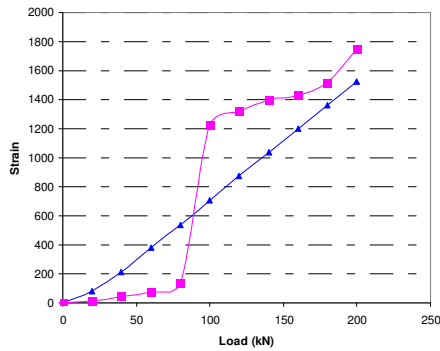

c) Beam NSC2, strain W_i on top of web bar (T12) and tension reinforcement T(20) not yielding.

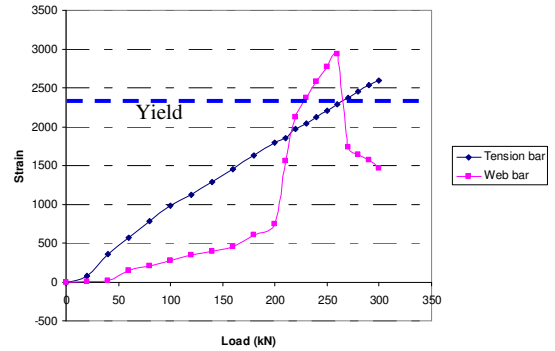

d) Beam HSC4 with strain W_i on top web bar (T25) and tension reinforcement (T20) yielding.

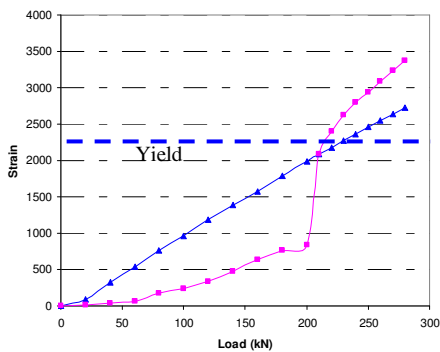

e) Beam HSC3, strain W_i on top of web bar (T20) and tension reinforcement (T20) yielding.

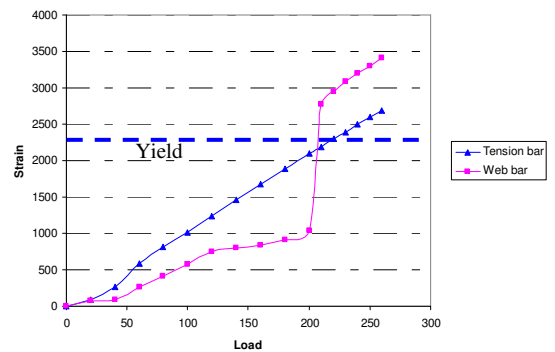

f) Beam HSC2, strain W_i on top web bar (T12) and tension reinforcement (T20) yielding.

Figure 6: Strains recorded in tension reinforcement T20 and on the upper part of HWB. Refer to Figure 4) to identifying location of strain gauge W_i on top surface of HWB

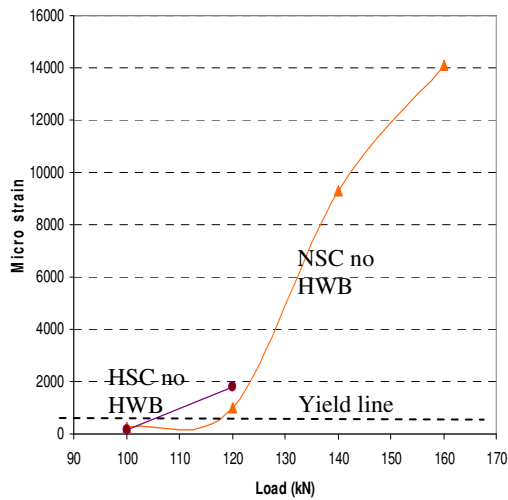

a) NSC1 and HSC1 (both without HWB)

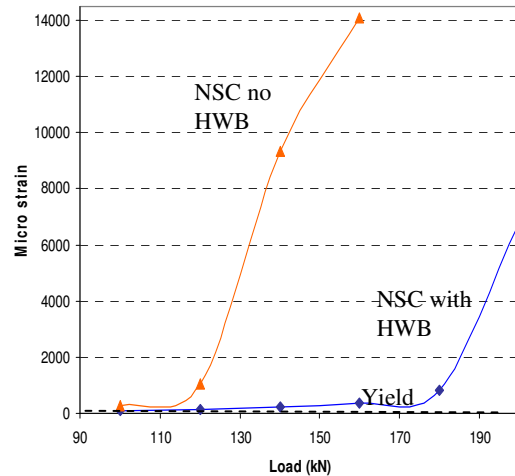

b) NSC1(no HWB) and NSC3(with 2T20)

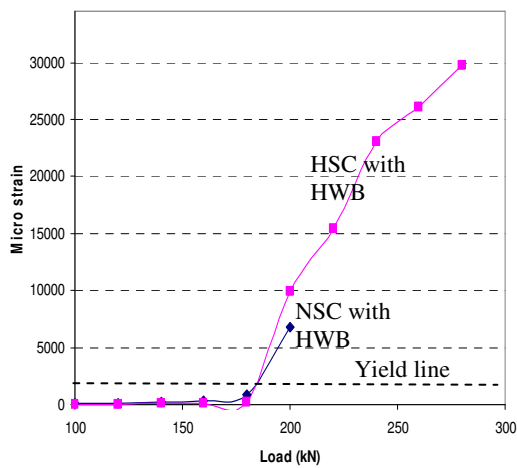

c) NSC3 and HSC3 (both with 2T20 HWB)

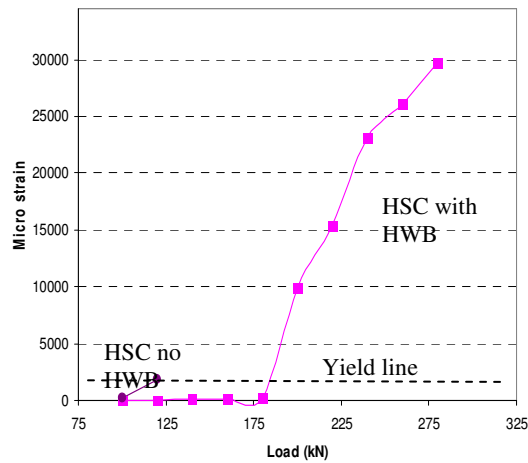

d) HSC1(no HWB) and HSC3 (with 2T20)

Figure 7: Influence of presence of HWB on strains in link 2 (at the centre of shear span) are compared for NSC and HSC

Note: see Figures 2 and 3 for location of link 2

Comparison of shear design rules for HWB

The test results from the experimental work in Table 1 with an average value for HSC1 beam compared with predictions from the proposed expression and Desai's equation are shown in Table 3. Further investigations by studying experimental tests for four normal strength beams without links with horizontal web steel tested to failure (Hejazi, 1997) are carried out, Figure 8. Concrete types for beams and their failure loads are shown in Table 5 Geometry, tension steel and amount of HWB in these four beams correspond to the four NSC beams shown in Figure 3 and Table 1. However, NSC beams in Figure 3 have stirrups, compression reinforcement and 3 T20 tension

Reinforcement compared to those in Figure 8 which have no stirrups or compression steel and 3T16 tension reinforcement. Comparing the value of f_{cu} in Table 5 and Table 1, the concrete strength of f_{cu} beam NSC3-0 and NSC3 with HWB of 2T-20 differs by 27% but the difference in f_{cu} in other matching pairs of beams is very small (0.03% to 0.08%). Modified Baumann design rule for shear prediction including the dowel action of the web bar remains conservative as the diameter of the web bar increases. Table 4 shows that the contribution of HWB to shear resistance in NSC beams V_{test} / V_{Bau} is 14% larger for beams with stirrups indicating that HWB is more effective in such beams.

Table 3: Experimental values of ultimate shear resistance compared to values predicted from the proposed and Desai's formulae for beams with horizontal web bars.

Beam No	NSC1	NSC2	NSC3	NSC4	HSC1	HSC2	HSC3	HSC4
f_{cu} (N/mm ²)	43.2	41.0	47.7	43.3	109.0	109.3	112.5	112.5
V_{cu} (kN)	56.1	55.2	58.0	56.1	76.4	76.5	77.2	77.2
V_{lu} (kN)	19.1	19.1	19.1	19.1	19.1	19.1	19.1	19.1
Web Steel	-	2T12	2T20	2T25	-	2T12	2T20	2T25
V_{bau} (kN)	-	10.2	15.6	17.1	-	14.1	20.7	23.5
$V_{cu(bau)}$ (kN)	91	100	108	108	111	125	132	135
V_{test} (kN)	80	101.5	100	105	65	132.5	140	150
$\frac{V_{test}}{V_{cu(Bau)}}$	0.88	1.02	0.93	0.97	0.59	1.06	1.06	1.11
$100\rho_b$	0	1.06	1.50	2.44	0	1.06	1.50	2.44
$V_c(1+0.4)$ (kN)	56.1	67.6	81.2	78.7	76.4	93.6	108.1	108.1
$V_{cu(Des)}$ (kN)	91	102	116	113	111	128	143	143
$\frac{V_{test}}{V_{cu(Des)}}$	0.88	1.00	0.86	0.93	0.59	1.04	0.98	1.05

Notes: BS 8110's limit on f_{cu} has been ignored.

*Average values of HSC1-1, HSC1-2 and HSC3-1 from Table 1 are represented as values of HSC1.

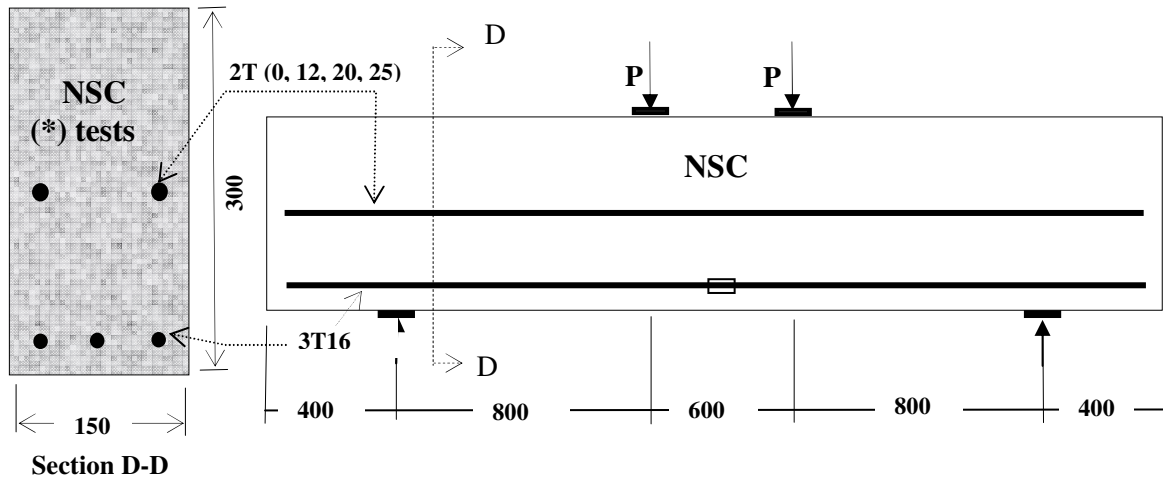

Figure 8: Four beams of NSC without stirrups with and without HWB corresponding to four beams shown in Figure 3.

Table 4: Comparison of accuracy of prediction of shear resistance of HWB for beams with and without stirrup

	Web bars	2T12	2T20	2T25
	ρ_b %		0.56	1.5
NSC	V_{test} / V_{Bau}	1.21	1.08	1.15
NSC*		1.06	1.02	0.95

Conclusion

This paper presents a shear design rule for beams with horizontal web bars which is shown to provide a more accurate prediction of shear strength than existing design equations

The proposed design rule is most accurate for beams with stirrups and gives the most consistent results when applied to higher strength concrete.

The use of strain gauges and Demec enabled the cracking and deformation of slender reinforced high strength and normal strength concrete beams with stirrups, with and without horizontal web steel, to be investigated at loads up to peak load.

Design rules proposed as a result of previous research by Desai hold fair for the beams tested here, as they produce reasonable estimates of ultimate shear resistance.

As shown in Table 5, a maximum 33% increase in shear resistance is recorded, the maximum improvement expected from HWB in NSC.

Table 5: Calculation of average stirrup support for HWB shear resistance

Web bar	0	2T-12	2T-20	2T-25
No links	NSC1*	NSC2*	NSC3*	NSC4*
F_{cu} (N/mm ²)	40.3	42.2	37.7	40
V_{test*} (kN)	48.9	57.5	65	63.5
With links	NSC1	NSC2	NSC3	NSC4
F_{cu} (N/mm ²)	43.2	41	47.7	43.3
V_{test} (kN)	80	101.5	100	105
V_s (kN)	18.72	18.72	18.72	18.72
$V_t - V_s$ (kN)	61.28	82.78	81.28	86.28
$V_{test} - V_s$ - V_{test*} (kN)	12.38	25.28	16.28	22.78
$V_{Support}$ (kN)	0	12.9	3.9	10.4

Research by Desai and Vollum and the present tests on normal strength concrete beams with stirrups shows that for normal strength concrete there is a limit to the maximum contribution of HWB for beams with or without links.

Design rules proposed by EC2 and BS8110 for normal strength concrete beams, with stirrups, and without horizontal web reinforcement are not valid if extrapolated to high strength concrete beams.

In general, the tests on high strength concrete beams proved that horizontal web reinforcement located towards the centre of the beam improves the shear resistance significantly.

The results for beam HSC1 compared with those for beams HSC2, HSC4 and NSC4 showed an enhancement of shear resistance of about 130% when horizontal web steel is provided.

Research by Desai and Vollum show that the horizontal bars can provide, for design purposes, when considering fire exposure, their location protected by the surrounding concrete would be of some advantage.

Further research will be required to find more realistic design rules for the enhancement of the shear resistance of high strength reinforced concrete members when horizontal web reinforcement is provided at the centre of the cross section.

Acknowledgements

The first author would like to acknowledge the support of late Jon Davis, the manager of the Construction Hall at The University of Westminster

References

- Al-Hussaini, A., Motamed, J. 'HSC beams with combination of links and horizontal web steel as alternative shear reinforcement'. *6th International Symposium on Utilization of High Strength/High Performance Concrete, Leipzig*, June 2002
- Baumann, T. "Tests to study the dowel action of the

- bending tension reinforcement of reinforced concrete beams," *Bericht Nr. 77*, Munich Technischen Hochschule, (English Translation by PCA), 1968
- Baumann, T., Rusch, H. 'Versuche zum Studium der Verdubelungswirkung der Biegezugbewehrung eines Stahlbetonbalkens, (Tests studying the dowel action of the flexural tensile reinforcement of reinforced concrete beams.) Berlin, Wilhelm Ernst und Sohn, 1970, Deutscher Ausschuss fur Stahlbeton, Heft 210. pp. 42-82
- BSI (2004) European Standard EN 1992-1-1:2004, Eurocode 2: Design of concrete structures, Part 1, General rules and rules for buildings, BSI, 2004, London.
- BSI (British Standard Institution) (1997) BS 8110 Part 1: Structural use of concrete: Code of practice for design and construction, London.
- Concrete Society: 'Design guidance for high strength concrete', *Tech. Rep. No 49*, Slough, The Concrete Society, 1998.(amended 2004)
- Desai, S.B. Horizontal web steel as shear reinforcement. *Magazine of Concrete Research*, Vol.47. No.171. June 1995.pp. 143-152
- Hejazi, J. '*Horizontal web steel as shear reinforcement*'. MSc dissertation, University of Westminster, 1997
- Kawar, A.N. N. '*Punching strength of plain concrete*', Dissertation, University of Birmingham, Dept. of Civil Engineering, 1980
- Kuchma D, Vegh P, Simionopoulos K, Stanik B and Collins M. P., 'The Influence of concrete strength, distribution of longitudinal reinforcement, and member size, on the shear strength of reinforced concrete beams' *CEB Bulletin d'Information No 237 - Concrete Tension and Size Effects*, 1997
- Morsch, E. 'Der Eisenbetonau, seine Theorie und Anwendung'. Published in English as 'Concrete-Steel construction'. New York, Engineering News Publishing Co. 1909 & McGraw-Hill Book Company, New York, 368pp translated from 3rd (1908) German edition. German publication of first edition (1902)
- Motamed, J. '*Shear in normal strength and high strength reinforced concrete beams with stirrups and horizontal web bars*'. University of Westminster, MSc Diss, 1997.
- Motamed, J., '*Monolithic beam to external column joints in reinforced concrete*'. University of Westminster', PhD thesis, May 2010.
- Regan, P. E., Kennedy -Reid I. L., Pullen, A. D., Smith, D. A. 'The influence of aggregate type on the shear resistance of reinforced concrete' – *The Structural Engineer*. 6 December 2005
- Rogowsky, D. M , MacGregor, J.G. "Design of deep reinforced concrete continuous beams," *Concrete International : Design and Construction*, Vol.8, No 8, August 1986, pp.49-58
- Taylor, H. P. J. 'Investigation of the forces carried across cracks in reinforced concrete beams in shear by interlock of aggregate', Tech. Rep. 42.447, *Cement and Concrete Association*, London, Nov 1970
- Walraven, J. '*Experiments on shear transfer in cracks in concrete, Part II: Analysis of test results*', Report 5-79-1 0, Dept of Civil Engineering, Delft University of Technology, Nov 1979