



HOST-SEEKING BEHAVIOUR  
IN THE MALARIA VECTOR  
*ANOPHELES GAMBIAE*

FRANCES MADELINE HAWKES

A thesis submitted in partial fulfilment of  
requirements of the University of Greenwich for  
the degree of Doctor of Philosophy

JUNE 2013

## **DECLARATION**

I certify that this work has not been accepted in substance for any degree, and it is not currently being submitted for any degree other than that of Doctor of Philosophy being studied at the University of Greenwich. I also declare that this work is the result of my own investigations except where otherwise identified by references and that I have not plagiarised the work of others.

Student's signature

Date

Supervisor's signature

Date

## **ACKNOWLEDGEMENTS**

This research was supported by studentship funding from the University of Greenwich's Research and Enterprise Fund. I am incredibly grateful for the opportunity the University has given me, and the support and encouragement I have received from so many people throughout my time at Greenwich and the Natural Resources Institute, both as an undergraduate and post-graduate student.

I cannot thank enough my supervisors, Dr Gabriella Gibson and Professor Stephen Torr, for all their support: scientific, technical, professional, practical, emotional and probably other ways I don't even realise yet. I think you took a chance on me and I hope I've not let you down. I would also like to thank my second supervisors who provided supervisory support at the beginning and end of the project, Professor Alan Cork and Professor Phil Stevenson, respectively.

My brief time in Burkina Faso was one of the most stimulating and profound experiences of my life and a genuine privilege. I am truly indebted to Dr Roch Dabiré and Dr Karine Moulin for their warm hospitality in Bobo and their continuing assistance with data sharing and grant applications. The Institut de Recherche en Sciences de la Santé (IRSS) and Institut de Recherche pour le Développement (IRD) were both very welcoming host institutes. Dr Frédéric Simard ensured we landed, ate, had somewhere to sleep in Ouagadougou and a way to travel on to Bobo, for which I am truly grateful. I kindly thank Karim, Harvé, Traore and Issa for looking after us and making the experience so memorable and successful, despite my terrible French! I hope to see you all soon!

None of this project would have been possible without the assistance of Natalie Morley, Dudley Farman, Mark Parnell, Caroline Troy and Professor John Orchard. From arranging visas, ordering random chemicals, managing my budget and helping with the student club, to bringing me horse blood

every fortnight, you have all been very patient with my bizarre requests and inability to fill in forms correctly. Thank you for keeping everything running, you've all been there when I needed you.

Thanks go to Dr Stephen Young for hours of help answering my statistics questions, ranging from the technical to the philosophical, and for help with making canny devices. I would also like to extend thanks to: James Broom and Dr Ian Dublon for their help maintaining our mosquito colonies, and for Ian's cheerful assistance with all things audio-visual during my techy learning curve; Gareth Jones for providing the lovely photographs of *An. gambiae*'s eyes; and all the students at NRI for their camaraderie. Again, I must thank IRSS for providing the initial colony of mosquitoes used in laboratory experiments and Dr Karine Moulin for sharing human landing catch data.

Thank you to my closest friends, Alex, Matt, Tammy and Vic (yes, I put you in alphabetical order), each of whom has helped to save a little bit of my sense of humour and perspective. My parents, June and Eric, my brother David and my extended family have all been incredibly supportive during my studies and I am grateful for all their encouragement, help and support, particularly with all the things outside of work – thanks to all my whānau!

Luke Whitehorn deserves the biggest thanks of all, not least for his patience in sharing his extensive knowledge of physics, maths and “computers” and his help with making many of the illustrative figures in this thesis. Luke, you've sat next to me the whole time I've been on this rollercoaster (and at times got out and pushed), even when geography got in the way; it is no exaggeration to say I couldn't have done it without you. Thank you 😊

## ABSTRACT

In sub-Saharan Africa, 90% of malaria cases are the result of transmission by the *Anopheles gambiae* species complex, causing 600,000 deaths annually. Increasingly, *An. gambiae* demonstrate behavioural and physiological resistance to control interventions and this, coupled with inadequate sampling methods, necessitates urgent development of new, efficient monitoring and control tools for malarial mosquitoes. The aim of this project was to examine the host-seeking behaviour of female *An. gambiae* to identify behavioural attributes that could be exploited in the design of novel trapping systems. To facilitate this, a wind tunnel arena with three-dimensional video-tracking was developed to quantify host-seeking flight of *An. gambiae* when presented with host-associated stimuli. In a constant flow of carbon dioxide and human-derived volatiles, mosquitoes were most active early in the night, suggesting a periodic responsiveness to olfactory stimuli, priming them to respond to potential hosts early in the night. Later spontaneous activity may increase the likelihood of encountering host odour plumes. Mosquitoes exhibited smooth and tortuous flight in up, down and crosswind directions in flows of clean and host odour-laden air, demonstrating a flexible suite of host-seeking behaviours. It is proposed that 'dipping' flight, consisting of high frequency vertical oscillations, may represent an alternative strategy to optomotor-guided anemotaxis in very low-light levels. When presented with black and clear targets in a flow of host odour-laden air, mosquitoes closely approached both targets more frequently than in a flow of clean air. Black targets were approached more frequently and collision avoidance was characterised by a rapid change to steep vertical flight. That mosquitoes avoided colliding with clear targets suggests involvement of an un-described sensory mechanism for detecting surfaces. Based on these findings, a prototype sticky trap incorporating a visual cue was tested in a malaria endemic region of Burkina Faso. The visually conspicuous trap caught more *An. gambiae* than a control trap, although both were equally efficient; additional design features could further optimise the visual trap. Overall, project results indicate that female *An. gambiae*

exhibit a variety of integrated stimuli-response mechanisms that control navigation through the environment and towards potential hosts. Furthermore, they validate the approach of using quantified behaviours to improve the efficacy of monitoring tools.

## TABLE OF CONTENTS

<b>1</b>	<b>Introduction .....</b>	<b>1</b>
1.1	Rationale .....	1
1.2	Aim .....	5
1.3	Objectives.....	6
<b>2</b>	<b>Literature Review .....</b>	<b>7</b>
2.1	Introduction.....	7
2.2	Mosquito biology.....	7
2.3	Activation and initial flight .....	12
2.4	Long-range orientation.....	16
2.5	Visual cues .....	26
2.6	Host selection, pre-attack resting and landing .....	31
2.7	Conclusion.....	35
<b>3</b>	<b>General Methods .....</b>	<b>37</b>
3.1	Background .....	37
3.2	Wind tunnel and flight arena design.....	40
3.3	Cameras, three-dimensional tracking and lighting .....	43
3.4	Three-dimensional data analysis .....	46
3.5	Mosquito colony.....	46
<b>4</b>	<b>Modification of Spontaneous Activity in Host-seeking <i>Anopheles gambiae</i> Presented with Host-associated Odours..</b>	<b>48</b>
4.1	Background .....	48
4.2	Materials and methods .....	51
4.3	Results.....	57
4.4	Discussion .....	61

<b>5</b>	<b>Characterising Host-seeking Flight in <i>Anopheles gambiae</i> in the Presence and Absence of Host Odour.....</b>	<b>64</b>
5.1	Background .....	64
5.2	Materials and methods .....	68
5.3	Results.....	78
5.4	Discussion .....	91
<b>6</b>	<b>Host-seeking Behaviour of <i>Anopheles gambiae</i> in Response to Visual and Olfactory Stimuli.....</b>	<b>100</b>
6.1	Background .....	100
6.2	Materials and methods .....	103
6.3	Results.....	108
6.4	Discussion .....	119
<b>7</b>	<b>Field Testing of a New, Visually Conspicuous Sticky Trap .....</b>	<b>125</b>
7.1	Background .....	125
7.2	Materials and methods .....	129
7.3	Results.....	133
7.4	Discussion .....	138
<b>8</b>	<b>General Discussion.....</b>	<b>146</b>
8.1	Activation of host-seeking .....	146
8.2	Host-seeking flight .....	148
8.3	The role of visual cues in host-seeking.....	151
8.4	Prototype trap design based on laboratory findings.....	153
8.5	Future research areas .....	154
8.6	Conclusions .....	156
<b>9</b>	<b>References.....</b>	<b>157</b>
	<b>Appendix A: Calculations for Track Analysis .....</b>	<b>188</b>



<b>Appendix B: Three-dimensional Animated Flight Track Graphs .....</b>	<b>191</b>
Supplementary material 5a: Smooth, tortuous and dipping tracks in clean air and host odour .....	191
Supplementary material 6a: Examples of tracks responding and not responding to a target .....	191
CD of Supplementary material 5a and 6a .....	192

## TABLE OF FIGURES

<b>Figure 2.1</b> Taxonomic classification of mosquitoes in relation to other closely-associated Diptera.....	8
<b>Figure 2.2</b> Life cycle of the mosquito.....	9
<b>Figure 2.3</b> Head of female culicid, showing mouthparts used for piercing the skin of, and imbibing blood from, a host.....	10
<b>Figure 2.4</b> Postulated optic flow fields for (A) upwind and (B) crosswind flight, mapped across the ventral region of an insect's visual field.....	17
<b>Figure 2.5</b> Representation of odour plume packets dispersing in the wind.	22
<b>Figure 2.6</b> Electroantennogram responses from an array of moth antennae positioned 150 cm downwind of a pheromone plume point source.....	23
<b>Figure 2.7</b> The displacement of an insect relative to the ground beneath (its track) is a vector sum of its course heading and displacement caused by wind-induced drift.....	25
<b>Figure 2.8</b> Schematic of a directional flight trap (ramp trap).....	30
<b>Figure 3.1</b> Example of a typical Y-tube, or dual port, olfactometer.....	38
<b>Figure 3.2</b> Three-dimensional visualisation of wind tunnel showing main components.....	42
<b>Figure 3.3</b> Orthographic projection of cameras' fields of view inside wind tunnel flight arena.....	44

<b>Figure 3.4</b> Aerial view of black infrared transmitting floor markers as captured by infrared-sensitive cameras. ....	46
<b>Figure 4.1</b> Exploded view of holding array, showing sixteen chambers that hold individual mosquitoes. ....	52
<b>Figure 4.2</b> Pre-treatment levels of movement-related activity for female <i>An. gambiae</i> across the scotophase (score of '1' for each 30 s period with any amount of walking, jumping or flying).....	58
<b>Figure 4.3</b> Mean activity scores for female <i>An. gambiae</i> for resting, walking, jumping and flying for each treatment group, recorded at hours 3, 6 and 10 of the scotophase.. ....	58
<b>Figure 4.4</b> Effect of host cues on the mean change in level of all movement-related activities (control score – treatment score) for constant carbon dioxide plus host odour (dark grey), pulsed carbon dioxide plus host odour (grey) and a treatment-control of no added host cues (light grey) .....	61
<b>Figure 5.1</b> Carbon dioxide concentration, ppm, across central cross-section of flight arena.....	71
<b>Figure 5.2</b> Diagrammatic representation of directional heading definitions used to categorise track directions as upwind, downwind or crosswind. ....	75
<b>Figure 5.3</b> Model of concentric hemispheric shell volumes centred around the black floor marker. ....	77
<b>Figure 5.4</b> Track parameters for smooth and tortuous tracks in clean air and host odour, $\pm$ SE. ....	81

<b>Figure 5.5</b> Change in mean 3D angle to due upwind (0°) of upwind (A) and downwind (B) tracks in clean air, ±SE.....	83
<b>Figure 5.6</b> Mean slope values for dip ascents and descents in clean air and host odour, ±SE. ....	85
<b>Figure 5.7</b> Summary of dip characteristics in clean air and host odour, ±SE. ....	86
<b>Figure 5.8</b> Spatial distribution of clean air data points in x (crosswind), y (up/downwind) and across the x-y plane.....	88
<b>Figure 5.9</b> Spatial distribution of host odour data points in x (crosswind), y (up/downwind) and across the x-y plane.....	89
<b>Figure 5.10</b> Comparison of distribution of data point distances from centre of floor marker in clean air and host odour treatments.....	90
<b>Figure 5.11</b> Simplified dispersal of odour from a point source, where r is the maximum distance of odour detection. ....	94
<b>Figure 6.1</b> Photographs of the ventral view of the head of male and female <i>An. gambiae</i> .....	101
<b>Figure 6.2</b> Example tracks reaching the minimum distance from the target (≤15 cm) required to satisfy 'response' criteria. ....	106
<b>Figure 6.3</b> Example tracks not reaching the minimum distance from the target (≤15 cm) required to satisfy response criteria. ....	107

<b>Figure 6.4</b> Proportion of mosquitoes activated in clean air and host odour during assays with either a clear or black target present in the centre of the flight arena, plus activation results when no target was present from experimental data presented in Chapter 5, $\pm$ SE. ....	109
<b>Figure 6.5</b> Proportion of tracks showing responses to clear and black targets in the absence or presence of host odour, $\pm$ SE. ....	111
<b>Figure 6.6</b> Mean minimum distance to clear and black targets of mosquitoes responding to targets in the presence of host odour, $\pm$ SE. ....	112
<b>Figure 6.7</b> Frequency histogram of minimum distance to clear and black targets of mosquitoes responding to targets in the presence of host odour. ....	113
<b>Figure 6.8</b> Mean flight parameters of mosquitoes not responding to the presence of a black target in clean air. ....	115
<b>Figure 6.9</b> Mean flight parameters of mosquitoes responding to the presence of a black target in host odour. ....	116
<b>Figure 6.10</b> Mean flight parameters of mosquitoes not responding to the presence of a clear target in clean air. ....	117
<b>Figure 6.11</b> Mean flight parameters of mosquitoes responding to the presence of a clear target in host odour. ....	118
<b>Figure 7.1</b> Schematic of sticky trap design. ....	130
<b>Figure 7.2</b> Mean catches of mosquitoes for sticky traps plus their adjacent E-net, $\pm$ SE. ....	135

**Figure 7.3** Total nightly catches of mosquitoes for clear and black sticky traps in relation to visible fraction of the Moon's illuminated disk..... 135

**Figure 7.4** Mean nightly catch of *An. gambiae* in up and downwind collecting trays for E-nets adjacent to clear and black traps,  $\pm$ SE. .... 136

**Figure 7.5** Mosquito catch from sticky traps as a proportion of sticky trap plus E-net catch  $\pm$ SE. .... 137

**Figure 7.6** Mean nightly catch of *An. gambiae s.l.* from different collection methods  $\pm$ SE. .... 138

## TABLE OF TABLES

<b>Table 1.1</b> Characteristics of the <i>Anopheles gambiae</i> species complex. ....	2
<b>Table 5.1</b> Flight track parameters used in analysis of three dimensional flight track data, their definitions and units. ....	73
<b>Table 5.2</b> Summary of data collected in flight characterization assays in clean air and host odour. ....	79
<b>Table 5.3</b> Flight height data for smooth and tortuous tracks in host odour and clean air. ....	79
<b>Table 6.1</b> Summary of data collected during target response assays in clean air and host odour with a clear target and a black target. ....	110
<b>Table 7.1</b> Total mosquito collections from all clear and black sticky traps and E-nets, baited with human odour over seven nights in Burkina Faso. ....	133

## GLOSSARY

**Allochthonous** Pertaining to biotic and abiotic material originating in a place other than where it is found.

**Anthropophagy (alt. Anthropophily)** The tendency of an organism to feed on humans.

**Anemotaxis** Movement oriented with respect to a current of air

**Apposition** An image formed when each ommatidium of a compound eye is stimulated only by light passing through its own lens system.

**Ecdysis** The moulting of the cuticle in some invertebrates.

**Eclosion** The emergence of an adult insect or larva from a pupal case or egg, respectively.

**Electroantennogram (EAG)** Technique that records voltage changes between the base and the tip of the antenna when an insect is exposed to volatile substances.

**Endogenous** Factors growing or originating from within an organism.

**Endophagy** The habit of feeding inside buildings, particularly human dwellings and animal shelters.

**Endophily** The habit of resting inside buildings, particularly human dwellings and animal shelters, after consuming a blood meal.

**Entrainment** The coupling of a self-sustained oscillation to an external oscillation, with the result that both have the same frequency.



**Exogenous** Factors growing or originating from outside an organism.

**Exophagy** The habit of feeding outdoors.

**Exophily** The tendency of an organism to spend a large part of its life cycle outdoors.

**Gametocyte** A cell from which reproductive cells develop.

**Gravid** A female distended with eggs.

**Haematophagy** The habit of feeding on the blood of another organism.

**Holometabolism** Complete metamorphosis of an insect through four life stages (egg, larva, pupa and adult).

**Instar** An insect larval stage between one moult and another.

**Johnston's organ** The collection of mechanosensory neurons found in the pedicel of the antenna that detect the motion of the flagellum on the third and final antennal segment.

**Kairomone** A chemical or mixture of chemicals that, when emitted by one organism, can induce an adaptively favourable response in another heterospecific organism, but does not benefit the emitter.

**Odour** The volatile emanation of a chemical or mixture of chemicals that stimulates an organism's olfactory organs.

**Oligophagy** The characteristic of feeding on a narrow range of food substances.

**Ommatidium (pl. Ommatidia)** The individual light sensitive units that form compound eyes.

**Opportunism** A flexible feeding behaviour whereby food is acquired from a variety of different sources, depending on their availability.

**Oviposition** Process of laying eggs by oviparous animals (those animals where little or no embryonic development occurs within the mother).

**Parous** Describes a female that has given birth to one or more viable offspring or has laid an egg or eggs.

**Rhabdom** The crystalline structure lying under the cornea and occurring in the central part of each ommatidium. Consists of micro-villi from photoreceptor cells and contains a visual pigment, rhodopsin.

**Speed (alt. Flight speed)** Displacement per second ( $\text{cm s}^{-1}$ ).

**Sporozoite** Motile, spore-like stage in the life cycle of some parasitic sporozoans (including the malaria parasite) that is typically the infective agent introduced to a host.

**Superposition** An image formed when ommatidia receive both light passed through their own lenses and those of adjacent ommatidia.

**Synanthropy** The characteristic of living in close association with human habitations.

**Taxis (pl. Taxes)** Directional movement towards (positive) or away from (negative) a source of stimulus.

**Vector** (*Biology*) An organism that carries a disease-causing organism from an infected individual to a healthy one. (*Mathematics*) A quantity possessing both magnitude and direction.

**Velocity** The direction and magnitude of displacement per second ( $\text{cm s}^{-1}$ ).

**Zoophagy (alt. Zoophily)** The tendency of an organism to feed on mammals other than humans.

# 1 INTRODUCTION

## 1.1 Rationale

The mosquito *Anopheles gambiae sensu stricto* Giles (Diptera: Culicidae) acts as the main vector of the human malaria parasite, genus *Plasmodium* Marchiafava and Celli (Heamosporidia: Plasmodiidae). There were nearly one million deaths from malaria in 2008, with an estimated 247 million cases worldwide (WHO, 2010). In order to inform effective and practicable vector control measures, it is essential that we develop a full understanding of mosquitoes' behavioural responses to the individual stimuli produced by their natural hosts (Torr, 1994; Ferguson et al., 2010). The specialist anthropophilic feeding preferences of *An. gambiae* and its close, synanthropic association with humans contributes to its success as a disease vector (Clements, 1992; Curtis, 1996). Gauging the role and relative importance of different host-associated stimuli may allow targeted, efficient management practices to be developed that effectually exploit quantified behavioural responses to these stimuli (Gibson & Torr, 1999).

*Anopheles gambiae* is a species complex (*An. gambiae sensu lato*), historically known for its diverse ecology and behaviour (Gillies & Coetzee, 1987). Attempts to delineate the sibling species within the complex date back to the 1940s and continue to this day, with the recent description and naming of two new species (Coetzee et al., 2013).

Table 1.1 lists the most current binomial nomenclature for the complex and briefly describes behavioural characteristics that are particularly pertinent to vector-host interactions. As the emerging nomenclature has not yet been systematically integrated into the literature and to enable easier reference to existing literature, the present research retains reference to *Anopheles gambiae s.s.*, unless otherwise declared as M or S molecular form and does not adopt the new binomial *An. coluzzii* Coetzee & Wilkerson **sp. n.** for M molecular form. Species names used here are as cited in the original article.

**Table 1.1 Characteristics of the *Anopheles gambiae* species complex.**

Name and author	Characteristics
<i>Anopheles amharicus</i> Hunt, Wilkerson & Coetzee <b>sp. n.</b>	Formerly <i>An. quadriannulatus</i> . Ethiopian distribution; considered exophilic, exophagic, zoophilic. Negligible role in malaria transmission (Torr et al., 2008).
<i>Anopheles arabiensis</i> Patton	Associated with arid climates. Zoophilic when livestock freely available, but will feed readily on humans regardless of the presence of other mammals (Gillies & Coetzee, 1987). Prefer to feed outdoors, but will enter houses in presence of human odour if cattle unavailable (Torr et al., 2008; Tirados et al., 2011b). Complex role in malaria transmission (Russel et al., 2011).
<i>Anopheles bwambae</i> White	Inhabits only the Semliki Valley, Uganda, breeding in brackish water. Reported to freely enter houses in nearby villages. Contributes to local malaria transmission (White, 1985).
<i>Anopheles coluzzii</i> Coetzee & Wilkerson <b>sp. n.</b>	Formerly <i>An. gambiae sensu stricto</i> Mopti (M) molecular form. Prevalent in West Africa. Associated with breeding in irrigated fields. Less dependent on rainy season for breeding, so contributes to transmission for longer periods of the year (Gimonneau et al., 2010). Considered strongly anthropophilic, endophagic, endophilic (Costantini et al., 1993; Besansky et al., 2004; Lefèvre et al., 2009). (Continued overleaf)

**Table 1.1 Continued**

---

<i>Anopheles gambiae sensu stricto</i> Giles	Formerly <i>An. gambiae sensu stricto</i> Savannah (S) molecular form. Found across sub-Saharan Africa, except for arid zones. Associated with breeding in ephemeral water bodies; role in transmission associated with breeding during the rainy season (Gimonneau et al., 2010). Considered strongly anthropophilic, endophagic, endophilic (Costantini et al., 1993; Besansky et al., 2004; Lefèvre et al., 2009).
<i>Anopheles melas</i> Theobald	Salt water species found on West African coast (Gillies & de Meillon, 1968). High levels of outdoor human biting reported (Reddy et al., 2011)
<i>Anopheles merus</i> Dönitz	Salt water species found on East African coast (Gillies & de Meillon, 1968). Known to feed in and outdoors on a variety of mammalian hosts. Some role in malaria transmission (Kipyab et al., 2013).
<i>Anopheles quadriannulatus</i> Theobald	Formerly all <i>An. quadriannulatus</i> ; now only used for southern African populations (Coetzee et al., 2013).

---

The high vectorial capacity of *An. gambiae* s.s. (both M and S form) in malaria transmission arises from the way its ecology and behaviour determine its contact with human hosts, particularly its endophagic and anthropophilic characteristics, coupled with its longevity. These place it in human-made habitats and result in repeated cycles of humans being bitten; this allows human malaria gametocytes to be picked up from one human by a mosquito, matured over 12 days in the vector's body, then deposited in

other human hosts as sporozoites, the causative agents of clinical human malaria (Curtis, 1996).

Reports of greater early-evening feeding occurring outdoors in wild populations of *An. gambiae*, driven by behavioural adaptations to intra-domiciliary interventions (Reddy et al., 2011; Russell et al., 2011) and chemical resistance to the insecticides certified by WHO for mosquito control (Ranson et al., 2009; Edi et al., 2012), highlight a pressing need for less biased, more cost effective mosquito traps to monitor population abundance, age-structure and infection rates, particularly for outdoor biting populations (Athrey et al., 2012; Shukla, 2012). Cryptic subpopulations with divergent behaviour and vector-host-parasite interactions are also emerging in sub-Saharan Africa (Riehle et al., 2011; Yakob, 2011; Stevenson et al., 2012). Moreover, it is increasingly acknowledged that outdoor control interventions will be needed to address residual malaria transmission in these exophagic and exophilic vectors; without these, there is a serious risk that current gains in reduced malaria morbidity and mortality may be lost (Gatton et al., 2013).

A more extensive understanding of the complete behavioural repertoire employed by *An. gambiae* during host-seeking flight might identify traits that could be exploited in the development of such monitoring and control devices. Torr (1994) reflected that successful monitoring and control of tsetse flies (Diptera: Glossinidae) has been founded on an extensive understanding of the complex behavioural sequence that guides blood-seeking tsetse from their resting sites, through odour plumes, to eventually land and feed on their hosts. Intermittently, apposite and ingenious field monitoring (Gillies et al., 1978; Torr et al., 2008), behavioural assay (Gibson, 1985; Gibson, 1995; Lacey & Cardé, 2011) and chemical ecology (Cork & Park, 1996) techniques have been used to elucidate aspects of the mosquito lifecycle, drawing on techniques developed for the study of tsetse flies. Yet, progress in advancing a wide understanding of host-seeking behaviour has been piecemeal, with olfactory assays representing a large proportion of research into trapping and control technology (Ferguson et al., 2010).

Furthermore, it is only recently that advances in technology have made it possible to apply some techniques used to study relatively large, diurnal tsetse, such as video tracking, to small, nocturnal insects like mosquitoes.

Given the changing dynamic of malaria transmission in sub-Saharan Africa, and the paucity of data relating to host-seeking behaviour in *An. gambiae*, it is timely to reinvigorate a systematic effort to understand the many aspects of environment, physiology and particularly behaviour that make *An. gambiae* such an efficient vector of malaria parasites (Curtis, 1996; Ferguson et al., 2010; Shukla, 2012). By using inter-disciplinary methods, this project therefore aims to apply the approach used to understand and, ultimately, control tsetse, notably the quantification of behavioural responses to host cues, to improve methods of catching and killing vector mosquitoes. Such an effort is also likely to contribute to a better understanding of the fundamental biology of this species, and perhaps other insects.

## **1.2 Aim**

The remit of this project is to increase our understanding of the sequence of host-seeking behaviours that take mated female mosquitoes from their resting sites, through odour plumes to their potential hosts. In particular, attention will be paid to the mosquito which acts as the main African vector of human malaria parasites, namely *An. gambiae*. It is anticipated that the project's findings can then be exploited in the development of control strategies for these vectors, thereby helping to reduce the spread of mosquito-borne malaria.

With this in mind, the project addresses three key aims. These are to:

1. Capture in three-dimensions the free-flight behaviours exhibited by *An. gambiae* in the presence and absence of stimuli implicated in host location, including olfactory cues from whole hosts and visual stimuli;



2. Quantify observed free-flight behaviours using new and existing metrics, whilst considering the ease with which assays could be adapted for result verification in the field; and
3. Suggest ways to exploit known behavioural responses to specific stimuli by incorporating relevant findings into the development of new, attractive trapping methods for monitoring and control of *An. gambiae*.

### **1.3 Objectives**

In order to achieve the project aims, several objectives have been identified, which consider the potential role of specific host-associated stimuli in governing host-seeking behaviour in *An. gambiae*. These objectives are to:

- Determine whether host-associated olfactory stimuli may influence the circadian periodicity of host-seeking activity in *An. gambiae*;
- Describe the free-flight behaviour of *An. gambiae* in a flow of clean air and quantify how this differs in the presence of natural olfactory stimuli from a whole host;
- Characterise the free-flight behaviour of *An. gambiae* in response to visually conspicuous and inconspicuous objects and determine whether any observed responses to these objects are altered by the presence of natural olfactory stimuli from a whole host; and
- Incorporate relevant laboratory results into the design of a new mosquito trap and evaluate its correspondence with laboratory findings and suitability as a monitoring and/or control tool through field testing.

## **2 LITERATURE REVIEW**

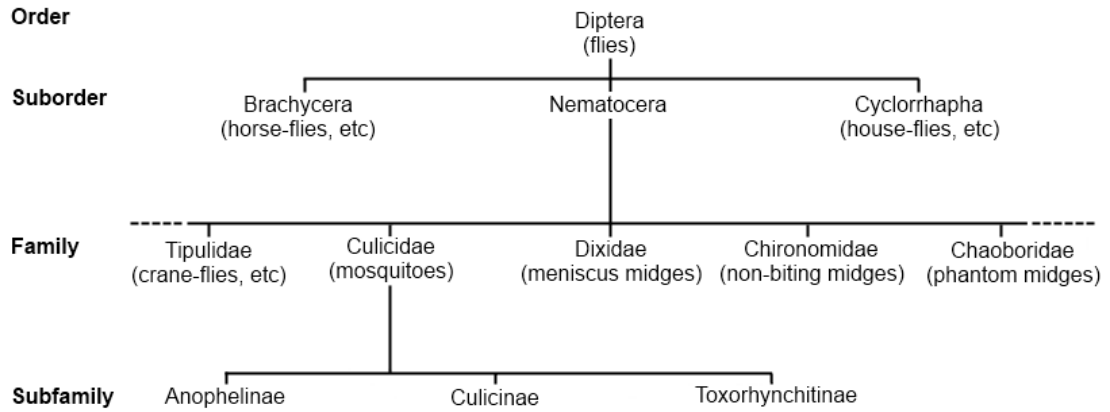
### **2.1 Introduction**

Haematophagous dipterans are capable of vectoring pathogens of both humans and livestock, and mosquitoes in particular are known to transmit the causative agents of dengue fever, malaria, yellow fever and arboviral encephalitides (CDC, 2007). Of particular epidemiological relevance is malaria, which caused nearly one million deaths in 2008, mostly among African children (WHO, 2010). The malaria parasite is transmitted to humans only by mosquitoes belonging to the genus *Anopheles*, although only around 25% of *Anopheles* species can carry the malaria parasite, *Plasmodium spp.* Marchiafava and Celli (Haemosporida: Plasmodiidae) (McGavin, 2003).

In order to break the cycle of malaria transmission, a greater understanding of the biology, ecology and behaviour of the main African vector species, *Anopheles gambiae sensu stricto* Giles (Diptera: Culicidae) (henceforth *An. gambiae*) may open the possibility for new ways of controlling the species.

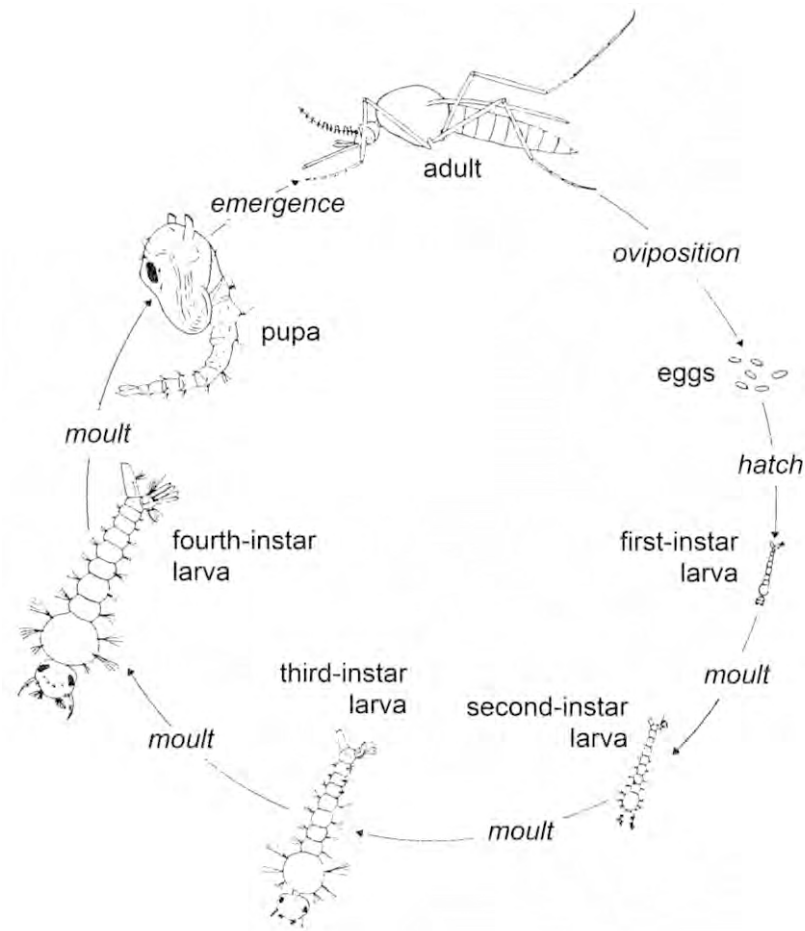
### **2.2 Mosquito biology**

Mosquito species belong to the order Diptera, or the true flies. Adults of this order are characterised by the presence of relatively large compound eyes, a mobile head and one pair of functional front wings, the second pair of hind wings having been reduced to form balance organs called halteres (McGavin, 2003). The mosquito family Culicidae belongs to the dipteran suborder Nematocera, meaning ‘thread-horned’, which refers to the long maxillary palps and multi-segmented, thread-like antennae found in members of this suborder. Nematocerans are slender-bodied with delicate legs and wings and often have aquatic larvae, as is the case with mosquitoes (McGavin, 2003). There are three subfamilies within the culicids: Toxorhynchitinae, Anophelinae and Culicinae, which together encompass ~ 3500 species of mosquito (Figure 2.1; Clements, 1992).



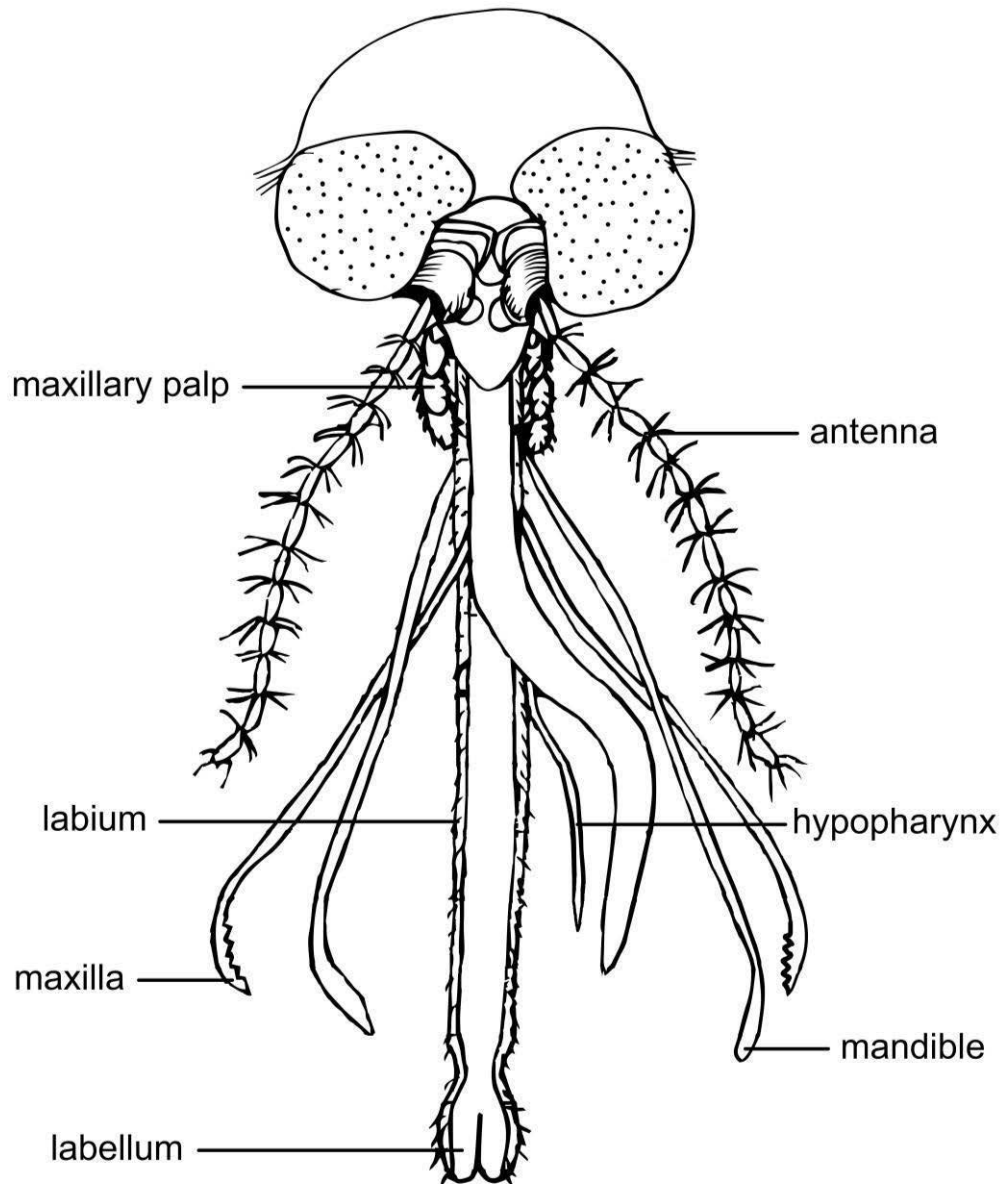
**Figure 2.1 Taxonomic classification of mosquitoes in relation to other closely-associated Diptera (After Snow, 1990).**

As holometabolic insects, mosquitoes undergo complete metamorphosis from an egg, through aquatic larval and pupal stages to a terrestrial adult stage, the whole cycle taking between 15-20 days (Figure 2.2; McGavin, 2003). The time to emergence of a larva from an egg is dependent on species and environmental conditions and typically takes between a few days and a few weeks. The aquatic larvae feed on particulate matter and organic detritus, but must remain in frequent contact with the water's surface in order to breathe air through a pair of spiracles which break the surface tension of the water. Larval mosquitoes proceed through four instars, the fourth ecdysis resulting in emergence of the non-feeding, but motile, pupal form. Within one or two days, depending on temperature, the fully formed adult stage will eclose from the pupal cuticle. Both male and female adult mosquitoes can survive by feeding on plant nectars with their elongate proboscises (Clements, 1992).



**Figure 2.2 Life cycle of the mosquito.** Only the adult stage is terrestrial, the others being aquatic (After Snow, 1990).

Females of anopheline and culicine mosquito species are obligate blood feeders, requiring the protein from blood to develop their eggs. They have serrated mandibles and maxillae, capable of sawing through the skin of a host; the whole stylet bundle is pushed through the skin, the surrounding labium folds back and blood can then be sucked up the food canal and saliva, which contains substances that can prevent haemostasis and closing of the wound, can be pumped down the hypopharynx into the host (Figure 2.3; McGavin, 2003). Thus, the act of blood feeding may result in a mosquito picking up blood-borne *Plasmodium* malaria gametocytes from, or passing their sporozoites on to, humans (Clements, 1992).



**Figure 2.3** Head of female culicid, showing mouthparts used for piercing the skin of, and imbibing blood from, a host. The stylet bundle is comprised of the maxillae, mandibles and hypopharynx (After McGavin, 2003).

Furthermore, with respect to their population dynamics, mosquitoes are r-selected strategists capable of ovipositing between 50 and 500 eggs at a time (Pianka, 1970; Clements, 1992); this makes human-enforced population control very difficult, because large numbers of eggs can be generated from a reservoir of only a few adult mosquitoes. Each adult female can survive

long enough to engage in ~ 4 oviposition cycles and therefore has the potential to become infected and re-infect subsequent hosts. It is these physiological characteristics, coupled with the strong anthropophagic habit of *An. gambiae*, which makes this species of mosquito such an efficient vector of disease (White, 1974; Curtis, 1996; Besansky et al., 2004).

Much research has focussed on improving our knowledge of the ways in which female mosquitoes search for, locate and finally land on and bite their human hosts, because this is the key vector-host interaction that perpetuates the spread of malaria, and other mosquito-borne diseases (Smallegange, et al., 2003). There are a wide range of sensory stimuli that can be detected by mosquitoes in their search for a blood meal, each thought to operate over different spatial scales. These can be broadly categorised as olfactory stimuli, the chemical cues emanating from a host, thermal stimuli, caused by the heat and convection currents in the close vicinity of a host, and visual stimuli also perceived by a mosquito within close range of a host (Clements, 1999). Olfactory stimuli are considered to operate over a metre or more away from the odour source (long range), visual stimuli around a metre to half a metre away (medium to close range) and thermal stimuli within centimetres of the host's body (close range) (Cardé & Gibson, 2010). In terms of the behaviours initiated by these stimuli, it is thought that mosquito host location begins with initial activation, which leads to long-range orientation along an odour plume, followed by a period of pre-attack resting, culminating in the final short-range approach and alighting on and probing the host (Clements, 1999; Gibson & Torr, 1999; Cardé & Gibson, 2010).

An awareness of the behavioural implications of each of the various stimuli involved in host location is key to developing more effective monitoring and control strategies for malaria mosquitoes and *An. gambiae* in particular. There follows a brief review of the current position of research in this field, examining in sequence what leads an inseminated female to a successful blood meal from a human host. This body of research forms the framework for the approach taken in this project.

### 2.3 Activation and initial flight

Activation is generally considered to be the induction of flight activity (Gillies, 1980) and consists of the transition from either a stationary position or ranging flight to movement towards a potential host, normally driven by an encounter with some form of host cue (Clements, 1999). The precise usage varies from author to author; here, activation is used to refer to the transition from a stationary position to either ranging flight in search of resource-related cues or immediate cue-following flight. It is thought that spontaneous activation is an endogenously controlled circadian rhythm in mosquito species and there exist variations in these circadian activity patterns, which are dependent on the physiological condition of the individual (Jones et al., 1974; Jones & Gubbins, 1979; Rowland, 1989).

Compared to virgin females, which have a peak of activity that coincides with male swarms at dusk, inseminated females of *An. gambiae* have high levels of activity throughout the night, indicating a shift towards a behaviour that may increase their chance of an encounter with a host or its odour cues (Jones et al., 1974). This shift is triggered by the insertion of male accessory gland hormone and the mating plug during mating, representing two mechanisms by which males increase the likelihood of their sperm fertilizing the next generation. In the short term, the mating plug prevents other males in the swarm from mating with an inseminated female, whilst the accessory gland switches the female from swarming at dusk to responding to host odours throughout the night, so she will rarely encounter another male (Jones & Gubbins, 1978; Clements, 1999). Circadian rhythms, coupled with physiological and environmental factors, are thus understood to govern the intensity of stochastic activity and therefore the occurrence of specific behavioural activities, including those relating to host-seeking.

Within the 'active' phase of its circadian pattern of activity, a mosquito can be activated directly by exposure to host cues. Perhaps the most ubiquitous chemical exploited by haematophagous arthropods searching for vertebrate hosts is carbon dioxide, which is not surprising since all vertebrates produce

this gas as a result of respiration (Takken & Knols, 1999). Kellogg (1970) showed through electrophysiological methods that neurones on the maxillary palps of *Aedes aegypti* Linnaeus (Diptera: Culicidae) mosquitoes were sensitive to sudden increases in carbon dioxide over a small range of 0.01 to 0.5%. This suggests that mosquitoes are sensitive to instantaneous changes in concentration of carbon dioxide (Gillies, 1980). This view is consistent with the identification of a phasic (rapidly habituated) response from peg sensilla on the maxillary palps of mosquitoes, an adaptation that has the evolutionary advantage of only generating a signal in the presence of a fluctuating source of carbon dioxide, which more likely represents a potential host (Kellogg, 1970; Dekker et al., 2005).

Experimental data increasingly support this concept. When exposed to continuous carbon dioxide in a flight tunnel, only 20% of *An. arabiensis* and 22% of *Culex pipiens fatigans* Say (now known as *Culex quinquefasciatus*) (Diptera: Culicidae) left a release chamber, and ~ 50% of those flew upwind (Omer, 1979). However, activation was increased when the carbon dioxide was introduced intermittently; ~ 50% of both species left the release chamber, with ~ 80% of these then flying upwind. In *An. gambiae*, ten 5 s pulses of carbon dioxide each followed by 25 s of clean air induced 60% of individuals to take off in a wind tunnel (Healy & Copland, 1995).

Variation in the fine-scale structure of carbon dioxide plumes, and the intermittent signals these deliver, have also been shown to result in different activation levels. Geier et al. (1999) described different activation levels in *Ae. aegypti* under exposure to three different plume structures: filamentous, turbulent and homogenous. The filamentous plume delivered the most intermittent carbon dioxide signal, based on measuring pulse amplitude and duration in a smoke simulation. Activation was highest in a filamentous plume of 4% carbon dioxide, high in turbulent plumes, and inhibited in a homogenous plume, possibly as a result of sensory habituation. Dekker et al. (2001) reported similar results for *An. gambiae*, with increased upwind flight



and trapping for this species in a turbulent plume of carbon dioxide compared to a homogenous plume.

The behavioural responses of mosquitoes to different concentrations of carbon dioxide have been studied extensively, particularly in relation to activation. Assuming an average tidal volume of ~ 500 mL and twelve breaths a minute, the average human respiratory volume is ~ 6 L min<sup>-1</sup>. Of this output, the carbon dioxide concentration is approximately 4.5% (Gillies, 1980). More zoophilic mosquito species, or those that are opportunistic in nature, tend to be more readily activated and attracted to carbon dioxide, due to its ubiquitous emission by all vertebrates (Costantini et al., 1996). In this regard, *An. gambiae* is considered to be more anthropophilic than other members of the *Anopheles gambiae* species complex and most other Afro-tropical mosquito species, in part due to its weak response to carbon dioxide baits compared to sibling species such as *An. arabiensis* (Costantini et al., 1996; Gibson et al., 1997).

Although 4% carbon dioxide activates mosquitoes in the field, low levels have been found to be sufficient to induce activation in the laboratory for several species. Daykin et al. (1965) reported that when exposed to 0.2% carbon dioxide in a moving air stream, *Ae. aegypti* were induced to take-off rapidly upwind for ~ 2 min, whereas clean air only saw random take-offs; this concentration was subsequently revised and lowered by Eiras and Jepson (1991) after activating *Ae. aegypti* with an increase in carbon dioxide concentration of as little as 0.03%. Healy and Copland (1995) recorded a similar response in *An. gambiae*, establishing that a threshold increase of as little as 0.01% carbon dioxide or higher activated around 60% of mosquitoes in a wind tunnel. Undiluted human breath resulted in the same level of activation as an approximately equal concentration of carbon dioxide, suggesting that other chemical components of human breath have a negligible effect on activation of *An. gambiae*.

Host odours can also play a role in the activation of host-seeking mosquitoes, appearing to function more effectively as an activator when presented alongside carbon dioxide (Clements, 1999). Omer (1979) tested the responses of *An. arabiensis* and *Cx. pipiens fatigans* to carbon dioxide and human hands. By introducing both of these stimuli to a wind tunnel, maximal departure from a release apparatus was achieved in both species, and the presence of carbon dioxide alongside the hand saw an increase of 20-35% in the number of mosquitoes trapped around the hand than achieved by the hand alone. For *An. gambiae*, significantly more individuals were activated and trapped when presented with homogenous skin odour plus turbulent carbon dioxide than with skin odour alone (Dekker et al., 2001).

Homogenous odour plumes elicit responses in mosquitoes, unlike homogenous plumes of carbon dioxide. A homogenous plume of human skin odour was observed to activate and induce upwind flight in *Ae. aegypti*; furthermore, a 100-fold increase in skin odour concentration increased activation from 40% to 95% of individuals and upwind flight from 10% to 87% of fliers (Geier et al., 1999). Dekker et al. (2001) found that a plume of odour caused significantly more activation than clean air alone. However, they also found that the addition of a plume of homogenous carbon dioxide reduced activation in the presence of homogenous skin odour. The mechanisms underlying this interaction are not well understood. Odour receptors are believed to be tonic and therefore mosquitoes should be sensitive to continual stimulation by host odours (Knols et al., 1997). The disruption to this expected outcome caused by the presence of a homogenous plume of carbon dioxide is difficult to unravel; additional and perhaps unknown mechanisms besides sensory adaptation may be involved (Dekker et al., 2001). These studies have shown that in addition to their roles as activators, carbon dioxide and skin odour can also act as attractants and possibly arrestants, highlighting the need for discerning bioassays to differentiate between these behaviours.

## 2.4 Long-range orientation

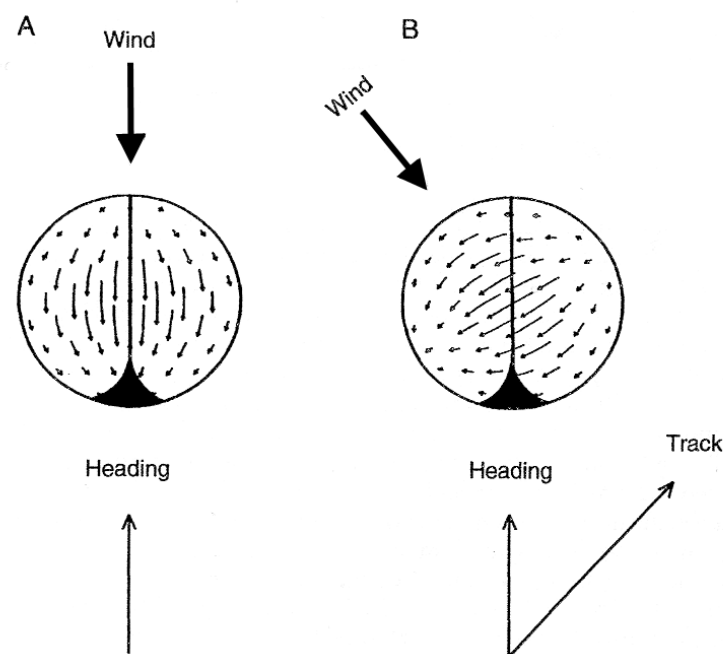
After receiving the initial cues that trigger activation, normally from a combination of both endogenous and exogenous sources, a mosquito must orientate and travel towards the potential host generating the exogenous cues. This process involves a number of complex elements. The focus of the following review will be the role of visual cues in facilitating upwind orientation and host location by mosquitoes, the effect of human odour on host-seeking and how plume structure can influence the success of upwind flight.

### 2.4.1 *Flight in moving air and optomotor-guided anemotaxis*

The morphological characteristics of the Nematocera, described in Chapter 2.2, account to some extent for the weak flying capabilities of insects within this suborder, including mosquitoes; in still air they generally reach speeds of only  $\sim 20 \text{ cm s}^{-1}$  (Gibson, 1995; McGavin, 2003). Despite this, it is often necessary for mosquitoes to fly upwind in search of a host. Locating a source of wind-borne cues, be they odour and/or carbon dioxide, requires the ability to detect both the chemical stimuli and the direction of the wind. Although odour plumes alert individuals to the presence of a host, they are not comprised of smooth concentration gradients and therefore cannot in themselves provide directional cues, so these must be obtained by detecting the direction of the wind carrying the odour (Cardé & Willis, 2008).

Based upon the landmark research by Kennedy (1940) with day-flying *Ae. aegypti*, and a wealth of research since then, it is understood that most insects use visual cues to orient themselves in relation to wind direction. By constructing a wind tunnel with a moveable floor pattern, Kennedy (1940) was able to show that as the floor pattern was moved in the same direction as the air flow, mosquitoes seemingly perceived this visual feedback as an indication that their flight speed had increased and responded by decreasing their actual speed in the air. So-called optomotor-guided anemotaxis remains the prevailing theory explaining how mosquitoes and other flying insects are

able to navigate relative to wind direction (Cardé, 2009). Further work has sought to elucidate details of the mechanisms at work. David (1982) described how *Drosophila hydei* Sturtevant (Diptera: Drosophilidae) use parallax cues to control their flight speed at different heights and went on to illustrate the proposed optic flow fields that traverse an insect's visual field (Figure 2.4; David, 1986). By minimising the transverse image flow across their ommatidia and turning either against or with the direction of image movement, an insect can thus achieve upwind or downwind flight, respectively.



**Figure 2.4 Postulated optic flow fields for (A) upwind and (B) crosswind flight, mapped across the ventral region of an insect's visual field.** The circles represent an insect's visual field and arrow lengths over these are proportional to the speed of image flow over the visual field (After David, 1986).

Reconciling a visually-driven mechanism with nocturnally active species such as *An. gambiae*, with poor visual resolution (Land, 1997) and, therefore, limited or no perception of visual cues, was addressed in a theory put forward by Gillett (1979). This suggested that flying insects may oscillate

through the atmospheric boundary layer, where viscous drag at the ground's surface slows wind speed (Denny, 1993); by dropping and rising abruptly through the vertical plane, it was hypothesised that an insect could perhaps detect with its mechanoreceptors a change in the apparent hind- or head-wind and adjust its track accordingly.

There is, however, little experimental evidence to support this idea, and it may be possible that even in extremely low light conditions, flying insects can use visual cues to determine their orientation to the wind in the way put forward by Kennedy (1939). Baird et al. (2011) have demonstrated that even in low light conditions of between 1 and 12 lux, the sweat bee, *Megalopta genalis* Meade-Waldo (Hymenoptera: Halictidae), can still process visual cues for flight control. Furthermore, in *An. gambiae*, Gibson (1995) was able to show empirically that individuals were capable of responding to a moving floor pattern with optomotor guided manoeuvres in white light levels as low as  $10^{-5}$  W m<sup>-2</sup> (moonless starlit night), and probably also in lower levels than this. These findings suggest that mosquitoes may well be able to use visual cues in very low light intensities in order to orient in moving air, although there may be limits, below which other, as yet unproven, mechanisms could take over.

#### 2.4.2 Odour cues

The chemical ecology of mosquito responses to host odours forms a large area of research, with implications for the *in vitro* formulation of odour profiles that can be successfully used to attract and trap host-seeking females, perhaps even in sufficient numbers to enable effective mass trapping (Takken & Knols, 1999; Okumu et al., 2010). An exhaustive review of the field cannot be covered here, and so an overview of the chemical ecology of anophelines mosquitoes is given.

Kairomones are chemicals or mixes of chemicals that, when emitted by one organism can induce an adaptively favourable response in another

heterospecific organism, but result in no benefit to the emitter (Whittaker & Feeny, 1971; Atkins, 1980). Thus, the odours emitted by humans are kairomones (often crudely referred to as attractants), as they are detected by the olfactory organs of host-seeking mosquitoes and allow them to locate and feed on the human source of the odours.

The development and experimental field application of odour-baited entry traps demonstrated conclusively that a number of disease vectoring mosquitoes are attracted by human kairomones alone, without the confounding presence of non-olfactory stimuli (Costantini et al., 1993). These traps, which draw odour-baited air from a host in a tent, through tubing to a box trap, were deployed in Burkina Faso and showed the markedly different catch composition that resulted from using different host odour sources. In a calf-baited trap, the ratio of *An. gambiae* to *An. arabiensis* was 8% to 92% respectively, whilst a human-baited trap caught 48% *An. gambiae* and 52% *An. arabiensis*; this approach thus confirmed the long-held notion that *An. gambiae* is far more anthropophilic than its sibling species within the Gambiae Complex. Furthermore, it suggested that the process of host differentiation appears to begin at some distance from the host, under the influence of different olfactory cues (Costantini et al, 1998).

Confirmation of the presence and effectiveness of host-specific airborne volatiles has informed research attempts at perfecting a formulation of synthetic attractive odours, or 'man in a bottle' (Takken & Knols, 1999: 140), that could be used to trap host-seeking mosquitoes. Much of this research has focussed on incrementally identifying the behaviourally relevant chemical constituents of human skin, a time-consuming task, given that human skin is associated with around 350 different chemical compounds (Zwiebel & Takken, 2004), although some recently formulated odour blends are reported to be as attractive as complete human odour (Okumu et al., 2010; Mukabana et al., 2012).

Cork and Park (1996) used gas chromatography combined with electroantennography to identify some of the compounds from human sweat which gave significant electrophysiological whole antennal responses in *An. gambiae*, including 2-hydroxypropanoic acid (lactic acid), which is formed as a result of anaerobic glycolysis in sweat production (Clements, 1999). 1-Octen-3-ol (octenol) occurs in very low concentrations in sweat samples, but also triggers an electrophysiological response in many mosquito species; it has been suggested that octenol may be at least one of the compounds used to differentiate between vertebrate hosts, as the antennal olfactory cells may be more sensitive to octenol in those species with more zoophilic feeding habits, such as *An. maculipennis atroparvus* van Thiel (Diptera: Culicidae) and *An. quadriannulatus* (Cork & Park, 1996; Takken et al., 1997a; van den Broek & den Otter, 1999). Ammonia, particularly in incubated sweat, has also been found to act as a kairomone to *An. gambiae* when presented in isolation and even in the presence of a repellent blend of several carboxylic acids; however, attraction was found to increase when both ammonia and the carboxylic acids were presented with lactic acid, although lactic acid is not considered a prerequisite in attracting *An. gambiae* (Braks et al., 2001; Meijerink et al., 2001; Smallegange et al., 2005).

These findings highlight the complex synergistic and antagonistic effects of various combinations, concentrations, volumes and ratios of chemicals thought to attract mosquitoes, and *An. gambiae* in particular. These results are already influencing the development of synthetic host odours (Okumu et al., 2010; Mukabana et al., 2012). However, most laboratory-based studies regarding olfactory 'attraction' are often limited to Y-tube-type assays and, whilst useful, are therefore limited by the weakness inherent when using these types of assay to comment on behaviour. Furthermore, Vickers (2006) notes that incomplete odour blends may not evoke 'natural' orientation behaviour. Although an essential starting point to begin identifying which of the myriad compounds may be involved in host location, laboratory studies on a larger spatial scale are necessary, to avoid mis-attributing particular

behaviours that result from the physical constraints of small dual ports or unnaturally extreme wind dynamics (Kennedy, 1977).

### *2.4.3 Plume structure*

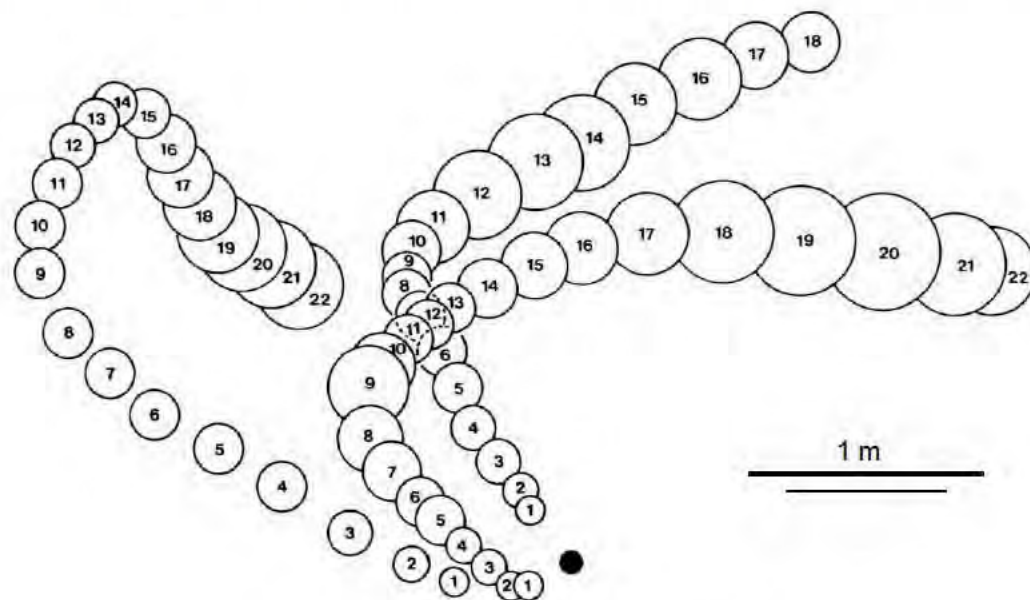
Irrespective of the precise formulation of the chemical compounds eliciting host-seeking flight in female mosquitoes, the spatial and physical characteristics of how these odour plumes are carried by the wind is of interest in understanding how mosquitoes are able to locate a host source generating a kairomone plume. Cardé and Willis (2008) define an odour plume as the volume throughout which the concentration of odour is equal to or greater than the behavioural threshold of the organism under study. However, odour plume phenomena are both difficult to observe and model experimentally, and so little is known of their precise characteristics (Cardé, 1996).

Murlis and Jones (1981) were able to demonstrate empirically that rather than having a continuous structure, odour plumes are in fact highly intermittent and appear downwind as a series of odour bursts, or packets, interspersed with pockets of clean air. Under their experimental setup, packet frequency could vary from between four times a second, to once every 20 seconds, and more frequent, shorter bursts were found closer to the source. Furthermore, packets were shown to have variable duration and odour concentration and so an instantaneous measure of these quantities would likely give an unreliable picture of an insect's position relative to the odour source; true chemotaxis is therefore unlikely to occur in plume following insects unless they are within only millimetres of the odour source (Cardé & Willis, 2008).

Vegetation and changing wind dynamics also affect plume structure. It has been hypothesised that in favourable conditions, with an open habitat, steady wind speed and small changes in wind direction, upwind flight would likely lead to an odour source, as the wind direction within any odour packet would



be aligned to the true origin of the odour (David et al., 1982, as reported in Clements, 1999). Such conditions rarely exist in nature and it has been found that, counter-intuitively, the instantaneous wind direction within a plume packet can often not be directly aligned with a plume's downwind axis (Elkington et al., 1987). In this case, flying upwind could lead an insect outside a plume, as the odour plume meanders downwind, at least in the horizontal plane (Figure 2.5; Elkington et al., 1987; Brady et al., 1989).

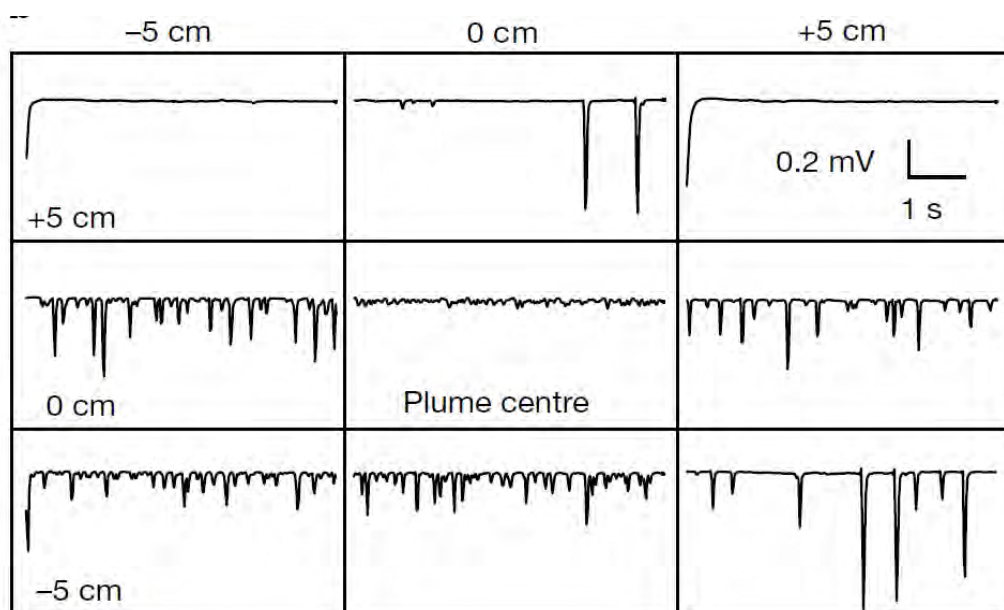


**Figure 2.5 Representation of odour plume packets dispersing in the wind.** Puffs of smoke originate at the black dot. Circles show successive positions and approximate diameters at 1 s intervals. Small and large scale bars show 1 m at ground elevation and 1.5 m elevation, respectively (After Brady et al., 1989).

The extent of this meandering is increased by the presence of physical obstructions in the landscape, including vegetation and buildings, which can force vertical and horizontal deviations in the path of a plume relative to wind direction (Cardé & Willis, 2008). Such obstacles can also contribute to unreliable directional cues within a plume, for as a plume moves around an obstacle, turbulent eddies and vortices are formed around the leeward sides

of the obstacle, which can result in air flowing in an upwind direction, back towards, rather than away from the source (Brady et al., 1989).

Complex fluid dynamics, shaping moving air currents and odour plumes, are beyond the remit of this review. However, Vickers et al. (2001) used an ingenious method to capture biologically relevant aspects of plume composition; by mounting an array of male moth antennae within a pheromone plume and performing simultaneous electroantennograms (EAG) on the antennae, they were able to record the spatiotemporal characteristics of the plume as it would be detected by a moth inside the plume. Mapping the pheromone's plume dynamics in this way shows position-dependent variation in the amplitude and frequency of EAG responses from the antennae (Figure 2.6).



**Figure 2.6 Electroantennogram responses from an array of moth antennae positioned 150 cm downwind of a pheromone plume point source.** Fine-scale spatiotemporal structure of the plume as represented by EAG depolarisation in a wind speed of  $60 \text{ cm s}^{-1}$ ; higher amplitude bursts were found at the periphery of the plume at higher wind speeds (After Vickers et al., 2001).

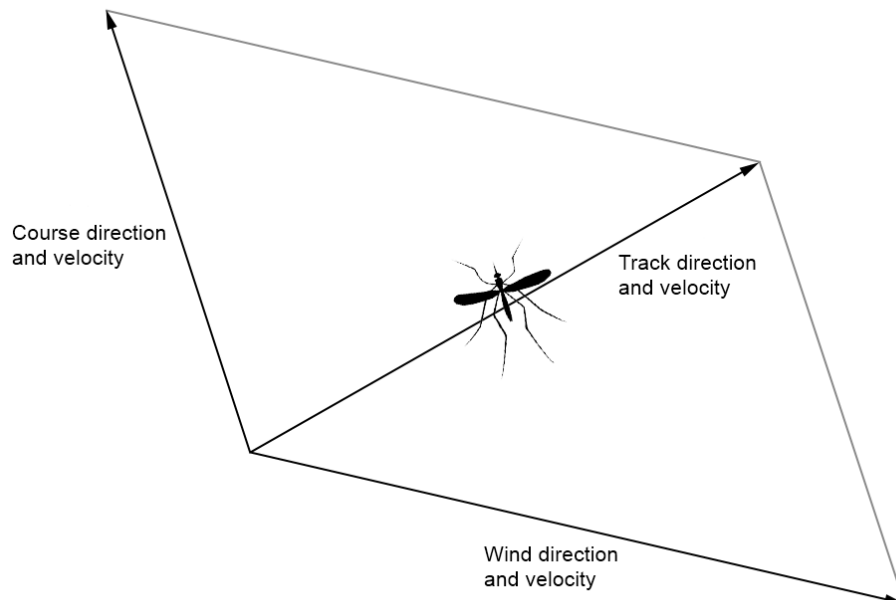
In addition, the authors fitted a free-flying moth with an EAG-linked third antenna and from these results found greater EAG responses when the moth was in flight, compared to when it was at rest, suggesting an organism's level of activity influences olfactory detection and possibly even the higher sensory representation of odour signals (Vickers et al., 2001).

Tracer gases, such as titanium tetrachloride, have also been used to visualise fine-scale plume structure, with photo-ionization detectors providing quantitative data relating to plume properties, such as plume area and signal concentration, fluctuation and intermittency, under various flow regimes. Justus et al. (2002) observed a plume disturbed by a downwind disc had higher intermittency, but lower peak concentration, than an undisturbed plume, whilst Girling and Cardé (2007) determine that signal intermittency increases with distance from the plume origin, even under different flow regimes, although a physical baffle upwind of the plume source increases the downwind distance at which air mixing occurs.

Our most fully developed understanding of plume following in insects relates to moths (Lepidoptera). These insects are known to create a zigzag pattern in the horizontal plane as they 'cast' crosswind, moving upwind only when they detect odour, and counterturning more frequently and rapidly when they lose contact with the plume (Cardé, 1996; Cardé, 2009). These insects provide inadequate analogues for nocturnal mosquito species such as *An. gambiae*: although they fly at similar ground speeds relative to wind speeds as mosquitoes, the plumes they follow tend to originate from a stationary 'point source' of female-specific pheromone (Cardé, 1996; Cardé & Gibson, 2010).

However, useful metrics derived from this field of study can be applied to the study of the flight manoeuvres of other flying insects, including mosquitoes. The most pertinent of these parameters are track, course and drift (Figure 2.7). A track refers to the three-dimensional path of a flying insect over the ground and is the sum of the insect's course (its direction and velocity

through the air) and the direction and velocity of wind-induced drift it encounters (Cardé, 2009).



**Figure 2.7** The displacement of an insect relative to the ground beneath (its track) is a vector sum of its course heading and displacement caused by wind-induced drift (After Cardé, 2009).

Further research is needed to increase our currently limited understanding of mosquito plume following behaviour; it is likely multiple navigational strategies are involved, as there is no one single consistent environmental condition in which plume following is likely to operate (Cardé & Willis, 2008). There is no clear consensus as to whether mosquitoes fly significantly upwind overall in the absence of host odours, and laboratory studies have often produced conflicting results. For example, *An. gambiae* has been reported in some studies to fly upwind in clean air and with exposure to a plume of carbon dioxide (Takken et al., 1997a), yet not to do so in a clean air stream in other studies (Healy & Copland, 1995). Neither *An. arabiensis* nor *Cx. pipiens fatigans* were induced to fly upwind in either a stream of moving air or still air conditions, only doing so in the presence of host odour cues

(Omer, 1979). Wind tunnel assays are also often biased towards over-representing upwind flight because insects are usually released from a downwind position. Differentiating the factors that instigate upwind flight and those that elicit host-seeking flight is particularly difficult, as both must to some extent involve sensory cues that exist in both situations (Clements, 1999). It is also crucial that other important modalities that affect host-seeking behaviour, such as visual stimuli, be considered alongside studies of odour-mediated flight, less their potential additive affects be neglected (Cardé, 1996).

## 2.5 Visual cues

Very little is known of mosquito responses to visual cues. Much of that which is known has been derived from day flying species, such as *Ae. aegypti*, and often does not relate to host seeking behaviour (Clements, 1999).

The structure and visual parameters of mosquito eyes differ depending on the photoperiodic host-seeking behaviour pattern of the species; that is to say their eyes differ on physiological, rather than taxonomical grounds (Kawada et al., 2006). The conical shape of rhabdoms within the ommatidia of nocturnal species, notably *An. gambiae*, appear to have evolved in response to the low light levels they encounter during their nocturnal activity, and allow them to capture more light than would otherwise be possible (Land et al., 1997). *Anopheles gambiae* have a resolvable angle calculated to be around 40°, with very high sensitivity to light (Land et al., 1997), whereas this parameter is about 12.3° in *Ae. aegypti*, which still have high sensitivity to light, albeit slightly lower than in *An. gambiae* (Muir et al, 1992). Nocturnal mosquitoes therefore appear to have developed an eye structure that sacrifices resolution for higher sensitivity to light.

*Anopheles gambiae* have such great sensitivity to light that, even when host-seeking in near darkness, visual cues may play an important role. Given that they have exhibited the visually dependent optomotor response in as little as

$10^{-5} \text{ W m}^{-2}$  of white light, a level congruent with one log unit of starlight, it would appear that discerning high contrast visual patterns is possible by this species in very low light conditions (Chapter 2.4.1; Gibson, 1995). Low light levels are likely to occur frequently in the field, particularly indoors, under dense vegetation or on nights with a new moon or heavy cloud cover. If visual cues are indeed used in the process of host-seeking, such an adaptation would appear to be very valuable in facilitating successful blood-feeding.

Insect eyes often have a zone of acute vision, where large facets and high acuity improve resolution (Land, 1997). With the exception of *Armigeres subalatus* Coquillett (Diptera: Culicidae) and *Toxorhynchites towadensis* Matsumura (Diptera: Culicidae), the facets of mosquito eyes are typically largest in the antero-ventral region (Land et al., 1999). This is unusual in insects, where antero-dorsal regions tend to be enhanced to facilitate pursuit of mates and prey on the wing; it is supposed that the larger ventral facets in most mosquito species are required to follow ground patterns during optomotor-guided navigation in very dimly lit conditions (Land, 1997).

The nocturnal flight behaviour of mosquitoes from different vegetative habitats is thought to differ in response to visual cues. This was investigated in Florida in relation to vertical and horizontal barriers (Birlingmeyer, 1975). On encountering a barrier, trap catches suggested mosquitoes retreated from the barrier, increased their elevation and then attempted forward flight, repeating the process until clear of the obstacle. Field species appeared to be more affected by barriers than woodland or intermediate species, and seemed to take fewer, larger steps, perhaps owing to the infrequency and scale of obstacles within an open field environment. Birlingmeyer (1975) hypothesised that this ascending flight may relate to the position of the horizon, at least for field species, as approaching a barrier would raise the apparent height of the horizon, and ascending would restore the horizon to an optically desired level. How this mechanism might function in woodland species is unclear.

Bidlingmeyer and Hem (1979 and 1980) conducted a series of experiments to further examine the visual attraction of mosquitoes to conspicuous objects in their environment. The first involved constructing suction traps from materials with different visual properties and with different structural characteristics, including black and weathered plywood traps with and without panels, transparent acrylic and buried traps with transparent acrylic or black coated risers and baffles (Bidlingmeyer & Hem, 1979). Those traps surrounded by black plywood caught the highest number of adult mosquitoes from eight out of the nine species caught in the study, suggesting a high visual response in nocturnal species. Based on the assumption that a transparent riser would be more difficult to avoid than an opaque one, it was concluded that the larger counts of mosquitoes caught in traps with an opaque riser must represent a positive attraction to the visual cue these create. Furthermore, the visible traps caught a lower proportion of blood-fed and gravid females, suggesting host-seeking females from many species are more attracted to conspicuous visual objects, or that gravid females may be repelled from them.

The transparent acrylic trap was deemed not to be entirely invisible to mosquitoes, as it caught numbers comparable to those traps with visible coverings (Bidlingmeyer & Hem, 1979). No mention was made as to how much the traps were handled before use, or if they were cleaned between nights, and it may be possible that residual volatiles from the hands of the experimenters remained on the surface of the traps, thus providing additional olfactory stimuli, or that changes in wind dynamics around the obstacles gave mosquitoes an indication of their presence.

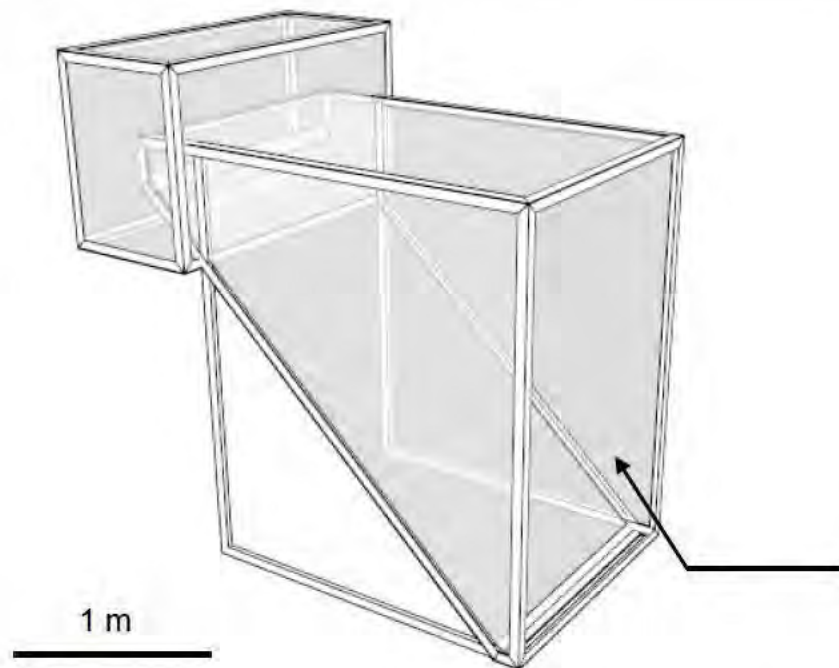
A subsequent study considered the effect of the competing visual cues created by adjacent traps. By laying out a regularly spaced grid of suction traps and comparing catches, it became apparent that trap catches were inversely related to the number of adjacent traps (Bidlingmeyer & Hem, 1980). Furthermore, catches from traps at the corner, edge and middle of the grid were thought to be proportional to the area over which the traps were

perceived by approaching mosquitoes. Working on this assumption and based on the distances between traps, it was determined that many species were responding to the traps' visual cues from between 15 and 20 m distance. *Uranotaenia sapphrina* Osten Sacken (Diptera: Culicidae) and *Cx. quinquefasciatus* were the only species found to have an even ratio of catches within all traps and, given trap spacing, appeared to be responding to the visual cues only when within 7.5 m or less of the traps. Ascertaining how these results would differ with the addition of host odours could provide additional data to elucidate whether the range and strength of visual attraction is modified in the presence of such additional stimuli.

A number of mosquito species have demonstrated two fundamental responses to visual stimuli or barriers when presented with and without odour: aversion and attraction. *An. melas* was shown to avoid unbaited directional flight traps (Figure 2.8; Gillies, 1969), yet when the same traps were baited with a calf, the number of individuals caught in the traps increased (Snow, 1976). This suggests that whilst the traps could be visually perceived by *An. melas*, they were avoided unless odour was present, indicating an odour-activated attraction to visual cues. In *Culex thalassius* Theobald (Diptera: Culicidae), however, there were high catches in the flight traps, regardless of the presence or absence of odour from the calf, with the highest number of catches on moonlit nights (Snow, 1976), implying a consistent attractive response to visual cues, enhanced when the traps were better illuminated. *Anopheles melas* is known to feed on bovids and other large mammals, whilst *Cx. thalassius* is an opportunistic feeder, including mammals, reptiles and birds in its host range (Clements, 1999). It is conceivable that the nature of their responses to visual cues reflects host seeking strategies that may lead to a suitable host; the less discerning *Cx. thalassius* may investigate any conspicuous object that could represent a host, whereas *An. melas* might avoid objects that may either be inanimate or not within its feeding range, and is only attracted to investigate visual cues that may indicate a suitable host when coupled with receipt of a host-



associated kairomone. Without additional experimental manipulation, such speculation remains empirically unsupported.



**Figure 2.8 Schematic of a directional flight trap (ramp trap).** Mosquitoes fly into the trap opening and are directed upwards by the ramp (see arrow) towards the funnel-like entrance of a collection box. Aligning the box relative to wind direction allows interpretation of flight direction (After Gillies, 1969).

Visual stimuli have an important role to play in how both nocturnal and diurnal mosquito species negotiate obstacles and barriers and respond to sightings of potential hosts. Given the scarcity of data relating to the use of visual cues in mosquito host location, there is a pressing need for further research, particularly in developing a better understanding of how responses to visual stimuli may modify or be modified by other stimuli. Trap catches could be greatly improved if evidence can be found to explain the relationship between multiple host cues, which likely have an additive effect in stimulating the chain of behaviours that leads a mosquito towards a potential blood meal.

## 2.6 Host selection, pre-attack resting and landing

Perhaps the least well understood behaviour associated with host-seeking is the final approach female mosquitoes take towards their hosts (Gibson & Torr, 1999). These behaviours are further clouded by issues of host preference and the degree to which a species will attack outdoors or indoors; this is of particular interest in the Gambiae Complex where ongoing research reveals an increasingly complex picture (Ferguson et al., 2010).

### 2.6.1 Host selection

Host preference is not easily ascertained, but the role of *An. gambiae* as the main vector of human malaria makes host-selection in this species of particular interest, as host-choice is a crucial determinant of the transmission intensity of *Plasmodium* (Curtis, 1996; Lyimo & Ferguson, 2009). Considered to be strongly anthropophilic, *An. gambiae* has shown a preference for human odours in laboratory assays (Pates et al., 2005) and in field tests (Costantini et al., 1998a). In the former, a dual-choice olfactometer study, individuals of *An. gambiae* were found to enter a trapping device readily, even when offered a choice of no odour versus no odour, suggesting a strongly endophilic character, although both *An. gambiae* and *An. quadriannulatus* indicated a strong preference for human odour over cow odour in the presence of carbon dioxide. In the later field study, which used odour-baited entry traps, *An. gambiae* demonstrated a stronger preference to human odour than cow odour, although 92% of *An. arabiensis* still preferred human odour over cow odour.

The lines differentiating zoophily, anthropophily, generalism and opportunism are necessarily relative, and there exists a high degree of plasticity in the host preferences of siblings within the Gambiae Complex, which is thought to have an underlying polymorphism for host preference (Besansky et al., 2004; Pates et al., 2005). Host choice is not even consistent within the *An. gambiae* sub-species, which shows spatial and temporal variation in host preference across Africa: compared to individuals in Tanzania, *An. gambiae*

from the Gambia were found to be 77 times more likely to choose cattle over humans (Killeen et al., 2001). Ecological adaptation of some species to human habitations and the close proximity of wild and domesticated animals in these areas creates a complex set of interactions in which individuals will take blood from non-preferred hosts when environmental conditions create such selective pressures (Clements, 1999). Moreover, the propensity for performing field work and collecting samples for human blood indexing in largely human-built habitations may upwardly bias our estimations of specialization across many mosquito species (Lyimo & Ferguson, 2009).

Even within a preferred host species, there is evidence of variation in the attractiveness of individuals to *An. gambiae* (Knols et al., 1995). Out of a group of 27 human subjects, skin emanations from each differed significantly in their attractiveness to female *An. gambiae* in a dual port olfactometer, and EAG readings showed higher amplitude responses to emanations collected from subjects that had elicited an 'attractive' behavioural response in the olfactometer assay (Qiu et al., 2006). It has yet to be determined if the greater attractiveness of some human subjects occurs as a result of the samples containing higher amounts of attractants, or lower amounts of repellents. Individual attractiveness is further confounded by infection with the malaria parasite *Plasmodium falciparum* Welch, which would stand to enhance its transmission if the attractiveness of its vertebrate host to mosquito vectors is increased. Conflicting reports on the behavioural effect of human malaria infection on mosquito host selection have as yet been unable to clarify the importance of this factor in host attraction (Lacroix et al., 2005; Mukabana et al., 2007).

Pregnant women in particular have been shown to be more attractive to *An. gambiae* than non-pregnant women. It is hypothesised that this may be a result of their higher respiration rate, or behaviours which increase their exposure to biting mosquitoes (Ansell et al., 2002). These findings may also relate to those of Port et al. (1980), who found that the proportion of blood meals taken by mosquitoes of the Gambiae Complex from persons in a

group under a bed net could be linked to the total weight or surface area that the individual person contributed to the group. Whether this effect can be attributed to the greater output of metabolic products, such as sweat and carbon dioxide, which would be present with heavier weight, or the higher heat profile created by a larger surface area, is still unclear.

### 2.6.2 *Pre-attack resting*

As alluded to previously, the nature of pre-attack resting and final short-range navigation to a host are very poorly understood (Gibson & Torr, 1999). Observations of *Anopheles* spp. moving to the vicinity of human dwellings and resting before their final approach makes a strong case for indoor residual spraying, where a resting mosquito will likely be in contact with sufficient pesticide to reduce longevity and reproductive success (Clements, 1999). The precise nature of, and mechanisms mediating such behaviour can only currently be speculated on, however it may be that in the same way that initial activation is triggered by particular kairomones and circadian periodicities, certain chemical or visual cues, in combination with an endogenous rhythm, may instigate a resting phase. Such a phase may proffer an ecological advantage by allowing a mosquito to collect directional information from host-associated cues, or to perceive movement from resting hosts. Experimental assays should allow for observation of this phenomenon and this could be achieved by increasing assay duration.

Thermal stimuli in the form of warm and moist convection currents are implicated in providing the close-range cues used by mosquitoes in their final short-range orientation to a host (Clements, 1999). Increasing relative humidity in one port of a dual choice olfactometer induced significantly more *An. gambiae* to enter when the alternative was stable or falling relative humidity (Takken et al., 1997b). In a vertical olfactometer bioassay, the thermal current created by a warmed dish increased the temperature of the air above to create a temperature gradient comparable to that created by a human hand; this induced significantly more *Ae. aegypti* to enter the trap below than in its absence. Water heated to 30°C had a similar effect,

significantly increasing trap catch of mosquitoes compared to that achieved with water at ambient temperature. Although convection currents and increased relative humidity resulted in mosquito responses, a human hand was significantly more attractive than the artificial treatment, presumably as it emitted a more complete range of both physical and olfactory host-associated cues (Eiras & Jepson, 1994).

Semi-field trials in which synthetic baits were augmented with heat, moisture or heat and moisture indicated that the later combination worked synergistically to increase the attractiveness of the bait to *An. gambiae* to a level equivalent to a highly attractive human (Olanga et al., 2010). However, moisture alone was ineffective in improving bait attraction, a result that may be due to test mosquitoes having free access to water before the assay, or fluctuations in humidity being associated with changes in behavioural response. Suffice to say, the precise role of heat, humidity and their associated convection currents requires further investigation and should focus on landing and probing behaviours, as these close-range activities seem likely to be influenced by such stimuli.

### 2.6.3 *Landing and biting*

Landing on a host, probing and biting represent the final stage in the successful search for a blood meal. It has been suggested that variations in the density of human eccrine sweat glands or skin temperatures can enhance the attractiveness of certain parts of the body to biting mosquitoes (De Jong & Knols, 1995). Although the experimental conditions in this study did not control for factors such as body stance or the effect of removing human breath on temperature and humidity profiles, it raised interesting questions about how a mosquito may locate its host in close, often dark conditions and suggests that different species may preferentially bite certain parts of the body. Both *Cx. quinquefasciatus* (Oduola & Awe, 2006) and *An. gambiae* (De Jong & Knols, 1995) are reported to bite the lower leg and foot region most readily, whilst *Anopheles albimanus* Wiedemann (Diptera: Culicidae) (Knols et al., 1994), *An. quadriannulatus* (Dekker et al., 1998) and

*An. atroparvus* (De Jong & Knols, 1995) are thought to locate bites around the face and head.

Whether these patterns can be attributed to the presence of attractive or arresting volatiles in the chosen area, or to the release of repellent compounds from non-preferred sites is as yet unverified. Dekker et al. (1998) demonstrated that the distribution of biting sites chosen by *An. gambiae* could be altered by changing the position of a human subject from sitting to lying with legs extended into the air; this implies that there may be an interaction between the odours that may stimulate landing and biting and convection currents, as a horizontal posture has a markedly different convective air stream than a vertical position (Clements, 1999).

Controlled laboratory assay of such specific behavioural responses as final attack and landing are associated with a number of difficulties. For example, although it was shown that *An. gambiae* would land readily on samples of sweat, sweat extract and 2-oxopentanoic acid rather than a control, this response only peaked after about four minutes; this may have been due to excess quantities of solvent having an initially retardant effect on landing behaviour (Healy & Copland, 2000). Such observations highlight the need to develop assays that allow sufficient time for the full expression of the complete suite of behavioural responses that may be prompted by the presented stimuli.

## **2.7 Conclusion**

In a field situation, the suite of behaviours involved in host-seeking are the product of a plethora of environmental and host-related factors. Identifying chemical blends that elicit upwind host-seeking flight only utilises one facet of the sequence which could lead to successful location of a host, or indeed successful trapping or biocide delivery. Attracting an individual mosquito to the vicinity of a synthetic odour source may, in fact, be redundant, given that human habitations in areas requiring mosquito monitoring and control will

always generate an abundant source of such cues. When considering the highly synanthropic tendency of *An. gambiae*, it could be expected that this species will always find human habitations a source of attractant odours and respond accordingly. Drawing vectors away from human habitations is only of use if they can then be trapped or killed before setting off in search of a real host.

An understanding of dwelling navigation and entry, host approach and landing behaviours is likely to inform the development of technologies that either maximise trap entry or enable the delivery of sufficient doses of insecticides to control vector populations of *An. gambiae*. Quantifying the effect of integrated stimuli should be the focus of future research that aims to exploit behavioural responses in the construction of effective lures or traps that can then be used for monitoring and control of vector mosquitoes, and *An. gambiae* in particular.

### 3 GENERAL METHODS

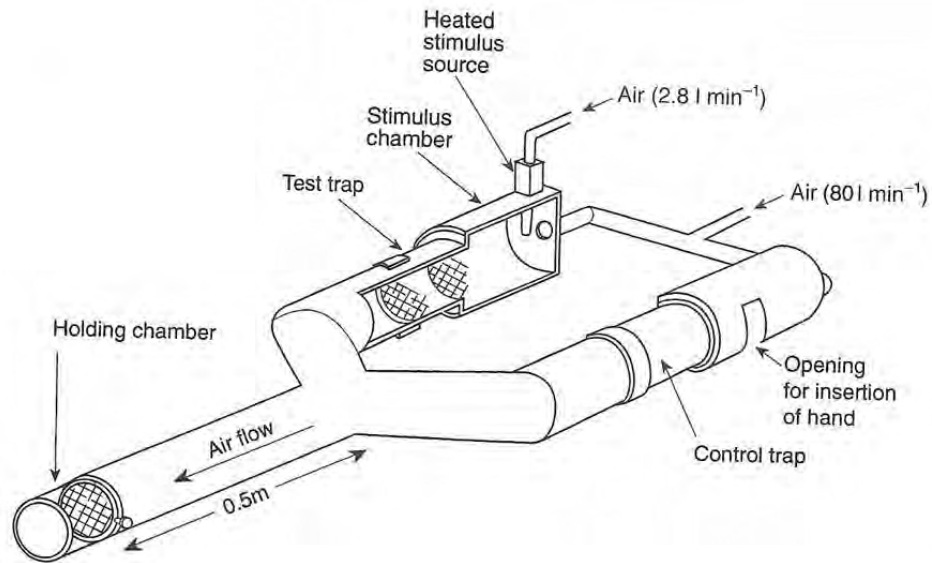
#### 3.1 Background

An increased understanding of the complete behavioural repertoire employed by *An. gambiae* during host-seeking flight could identify traits which can be exploited in the development of monitoring devices. Reports of increased outdoor feeding in wild populations of *An. gambiae* (Russell et al., 2011), driven by behavioural adaptations (Reddy et al., 2011) and chemical resistance (Edi et al., 2012) to indoor interventions, highlight a pressing need for less biased, more cost effective mosquito traps to monitor population abundance, particularly for outdoor-biting populations (Athrey et al., 2012).

Directly observing the behaviour of relatively small and nocturnal insects can be problematic in the field; laboratory-based assays offer a favourable starting point from which to begin quantifying the free-flight of mosquitoes, and nocturnal mosquito species in particular (Cardé & Gibson, 2010). Following advances in software and video equipment, the technology to electronically capture, process and reconstruct in three dimensions the flight activity of nocturnal insect species has become more affordable and more readily available.

Small-scale olfactometers have traditionally been used in determining the response of insects to different odour blends and, although the resulting responses are often described as behavioural, the test insect is usually presented with a binary choice, as is the case with widely used Y-tube olfactometers (Figure 3.1). This effectively limits any response to an *either/or* outcome, but provides an essential starting point for determining an insect's overall response in terms of attraction or repellence (Clements, 1999).





**Figure 3.1 Example of a typical Y-tube, or dual port, olfactometer.** The branches of the 'Y' contain putative attractants, repellents, or controls. Insects released from the holding chamber travel up the length of the single tube, then 'choose' which branch to continue down, presumably based on an 'attractive' or 'repellent' response to the odour emanating from a stimulus chamber (reproduced from Clements, 1999).

However, such assays are not suitable for elucidating behavioural mechanisms for a number of reasons. Conceptually, they are based on grouping different behaviours or series of behaviours into all-encompassing categories, largely based on responses to chemical stimuli alone (Kennedy, 1978). In practical terms, there are also limitations which make them unsuitable for teasing out specific behaviours. In Y-tube and dual port olfactometers (Figure 3.1), steep odour gradients often exist between the two ports emitting test substances, as well as wind shear as the two air streams converge. Furthermore, small olfactometers can confine an insect's movement whilst possibly providing distorted visual cues, due to the close proximity of bounding walls on all sides (Daykin & Kellog, 1965; Kennedy, 1977). For example, Geier et al. (1999) and Geier and Boeckh (1999) used a wind tunnel with a diameter of 8 cm and a working length of ~ 80 cm. This can confound attempts to measure the processes at work, as a test insect may be responding to these uncontrolled elements. Gibson and Torr (1999)

emphasise the importance of using whole hosts, rather than unnaturally high doses of particular odour components, reflecting the observation of Clements (1999), who laments that “almost nothing is known of the flight behaviour of mosquitoes in *natural* host odour plumes”.

Studies over the last decade have made progress in addressing these concerns, and have utilised free-flight arenas to observe the behaviour of mosquitoes. These experiments have tended to focus on small-scale presentations of odour plumes with fine differences in the composition of the odour plume. For example, Geier et al. (1999) found *Ae. aegypti* exhibit different flight responses when exposed to plumes with a filamentous, turbulent or homogenous structure, whilst Dekker and Cardé (2011) presented *Ae. aegypti* with turbulent and filamentous human odour and carbon dioxide and observed moth-like casting when test-individuals left the odour plume and upwind surging when they were inside the odour plume. These plumes ranged in diameter from 0.14 cm (Geier et al., 1999) to 0.5 cm (Dekker & Cardé, 2011). Such data has been invaluable in determining the sensitivity of mosquitoes to particular odour plume structures, helping to make clear some of the behavioural repertoire that the organism has at its disposal when faced with these odour plumes.

However, neither of these experiments use host odour derived from a whole host. Although it is important to present stimuli in a controlled fashion, it is also vital that we understand the behavioural responses of mosquitoes to the complex composite cues they will be exposed to in the wild from whole host odour sources (Vickers, 2000). Particular responses have been selected for in this wild environment over evolutionary time (Vickers, 2000) and so behavioural, transduction and processing responses to evolutionarily relevant stimuli may not necessarily resemble the behavioural patterns observed in responses to odours and plume structures that may never present themselves in the field. Chow et al. (2011) note the multimodal integration of sensory stimuli allows “neural circuits to be activated in a behaviourally context-specific manner.” As such, it is important to build on

existing behavioural studies with experiments that allow multiple stimuli to be presented in a way that closely resembles the characteristics the stimuli may have in the wild and this experimental context has been applied in this research.

### **3.2 Wind tunnel and flight arena design**

Kennedy (1977) outlined some fundamental principles that should be considered in developing assays which move beyond the limitations described above. Key elements of effective wind tunnel design include:

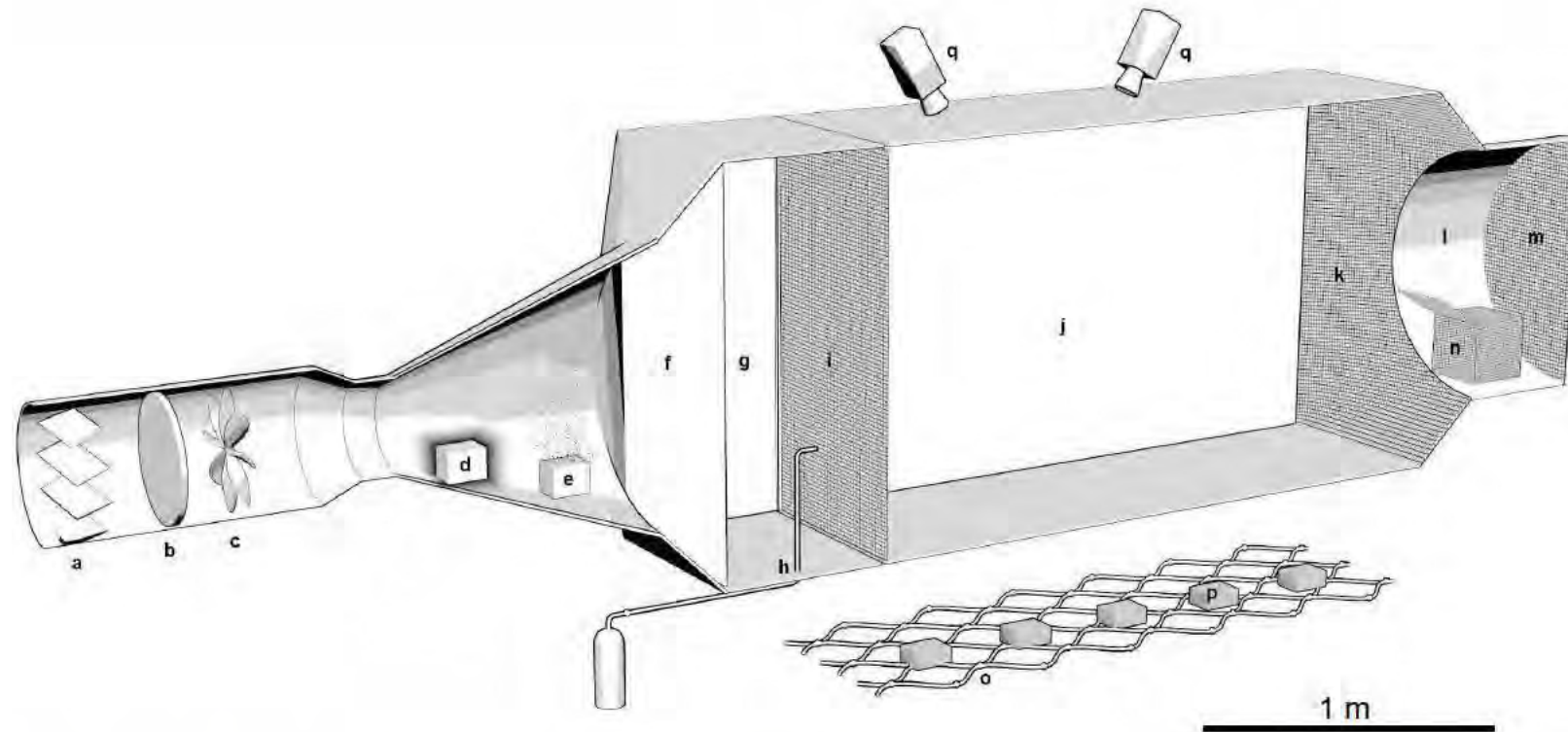
- A laminar air flow, to reduce the effects of mechanical cues and to allow for homogenisation of temperature and humidity.
- A host odour source which can be presented as a plume, simulating the spatial variations of plume structure that would be expected in the field.
- A sufficiently spacious flight arena in which test insects can execute flight manoeuvres unconstrained by the dimensions of the arena and to which objects can be added without restricting flight.
- Controlled visual cues that provide sufficient optomotor feedback for flight orientation.
- Suitable lighting arrangements that mimic night conditions for nocturnal species, whilst allowing suitable recording to take place.
- A means to record flight parameters remotely and without encroaching on experimental conditions or creating additional cues.

These elements have been adapted and drawn on in the design and construction of the wind tunnel and flight arena devised for the current research. With the intention of addressing the research aim and objectives (set out in Chapter 1), the experimental arena facilitates three-dimensional

tracking of the flight behaviour of *An. gambiae* in response to olfactory, visual and physical stimuli.

A cross-section schematic of the wind tunnel and flight arena designed for and used in this research is shown in Figure 3.2. The working flight arena (1.2 x 1.2 m; length 2 m) is environmentally controlled at  $25 \pm 2$  °C and  $65 \pm 5\%$  RH. Flight arena walls and floor are constructed of white opal Perspex (The Plastic Shop, UK), the roof of clear Perspex (The Plastic Shop, UK) and the upwind impelling section of brushed black steel.

An impelling fan (Fischbach GmbH, Germany), draws in clean air from outside the building (at two storeys height), which then passes through a charcoal filter and is heated and humidified with a 2 kW fan heater (Glen, UK) and atomising humidifier (Hydrofogger, USA), respectively. A screen of brushed cotton restricts the immediate downwind flow of air; the air pressure behind this screen forces the air across the surface of the screen and then evenly through the fabric, creating a laminar air flow into the odour delivery chamber. The system is, therefore, capable of maintaining laminar air flow of  $0.1 \pm 0.02$  m s<sup>-1</sup> as measured at an array across the downwind side of the brushed cotton screen. White netting screens the flight arena from potential visual cues within the odour delivery chamber.



**Figure 3.2 Three-dimensional visualisation of wind tunnel showing main components.** (a) shutter; (b) charcoal filter; (c) impelling fan; (d) fan heater; (e) atomising humidifier; (f) brushed cotton screen; (g) odour delivery chamber; (h) carbon dioxide source; (i) net screen; (j) flight arena; (k) downwind net joining j and l; (l) insect release chamber; (m) terminal downwind netting; (n) insect release box; (o) fairy light net on laboratory floor; (p) infrared light emitting diode array; (q) video cameras.

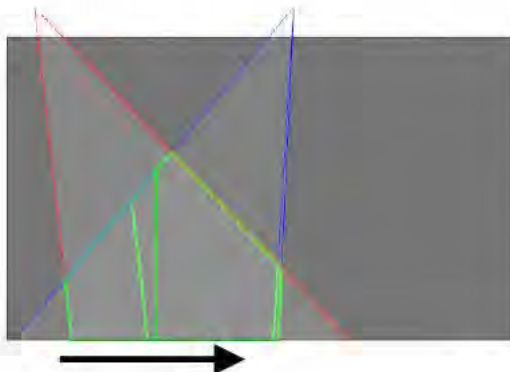
### 3.3 Cameras, three-dimensional tracking and lighting

Two high resolution analogue cameras (SHC-735p; Samsung, Korea) fitted with a 1/3" infrared corrected, C mount varifocal lens ( $f:1.0$ ) with auto-iris were mounted 10 cm above the flight arena facing towards each other at  $\sim 20^\circ$  from the vertical to create an overlapping field of view (equivalent to an area covering  $\sim 60 \times 85$  cm on the arena floor, shown in Figure 3.3) to enable 3D tracking. The camera signal is split and sent to a PC, where 3D flight coordinates are obtained in real time at 50 Hz by TrackIt3D (BIOBSERVE GmbH, Germany; Fry et al., 2000), and a digital video recorder (SRD-470D, Samsung, Korea), for later video playback and data validation.

Figure 3.3 shows the field of view of both cameras and the area of overlap between the two in which 3D tracking is possible. An area corresponding to highest carbon dioxide readings ( $> \sim 1500$  ppm) in tracking experiments is indicated by the solid orange circle; the dashed orange circle represents a plume of greater than background concentration carbon dioxide ( $> \sim 1000$  ppm). Background environmental carbon dioxide is  $\sim 380$  ppm and ambient background levels inside the arena when no additional carbon dioxide is added are approximately 460 ppm; this discrepancy is likely a result of the urban situation of the laboratory and its proximity ( $\sim 15$  Km) to a coal-fired power station. Although there are clean air corridors either side of this odour plume, they fall outside the area of 3D tracking.

Lighting within the arena is designed to mimic the low light levels experienced by *An. gambiae* when it is most active, i.e. during crepuscular and nocturnal periods. The flight arena is lit from beneath by an array of 208 white light emitting diodes (LEDs) (Kontsmide, Sweden), providing  $0.001 \text{ W m}^{-2}$  of visible light in the range 420 to 680 nm. This is equivalent to full moonlight illumination (NASA, 1969; Young et al., 1987).

Side view (y-z axis)

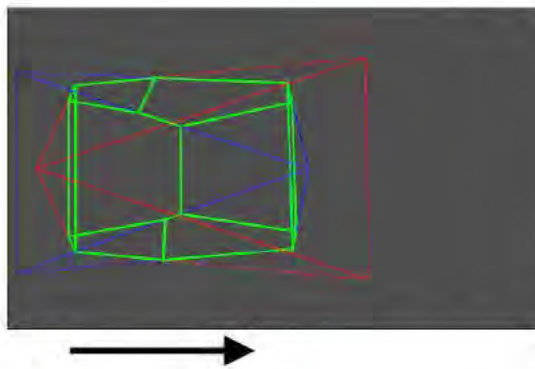


1 m

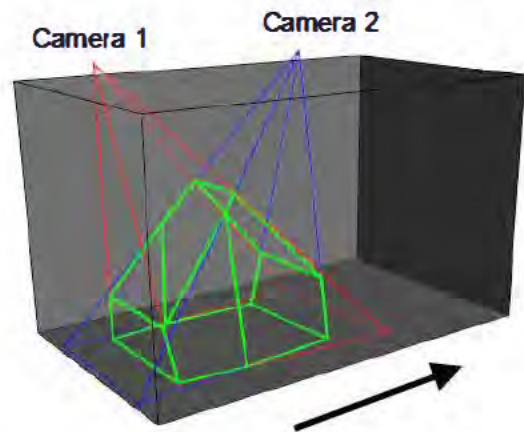
Crosswind view (x-z axis)



Aerial view (x-y axis)



3D projection

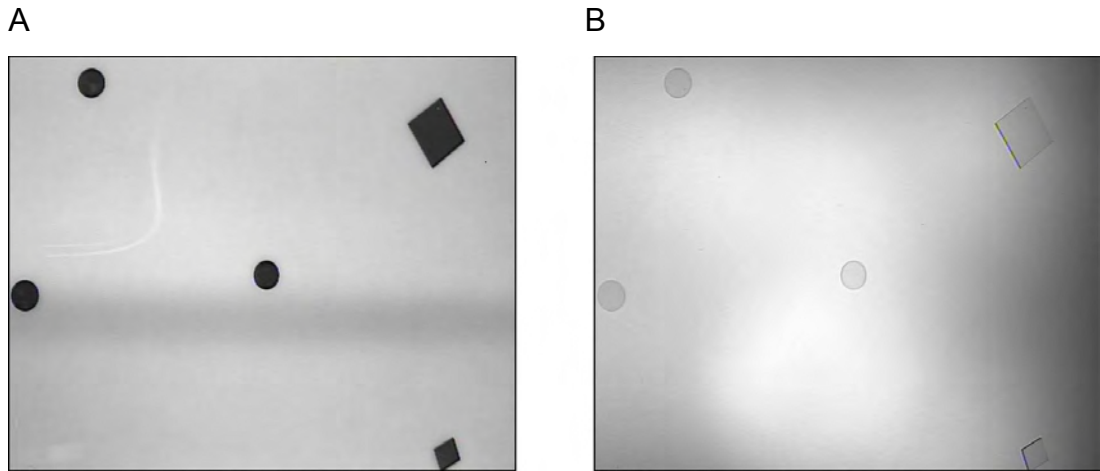


**Figure 3.3 Orthographic projection of cameras' fields of view inside wind tunnel flight arena. Green polygon denotes area where field of view from camera 1 and camera 2 overlaps; this is the space in which 3D tracking is possible. Solid orange circle in crosswind view indicates approximate position of highest concentration carbon dioxide plume (~ 1500 to 2000 ppm); dashed orange circle represents plume of carbon dioxide above background concentration (> 1000 ppm, background ~ 460 ppm; see Chapter 5). Arrows indicate wind direction.**

Additional lighting is provided for the cameras to improve contrast between mosquitoes and the floor, against which they are silhouetted. Ten infrared (IR) LED arrays (880 nm, 40° beam angle; Tracksys, UK) are positioned beneath the flight arena and arranged to evenly illuminate the cameras' shared field of view; IR-LED wavelength matches the peak sensitivity of the cameras but is beyond the range of visual perception in *An. gambiae* (Gibson, 1995).

To create contrasting visual patterns, which would generate an optic flow field across the eyes of flying insects, circular black markers (10 cm Ø; depth 0.3 cm) of an infrared transmitting plastic (Instrument Plastics Limited, UK) were placed at random across the floor of the flight arena; feedback from the displacement of these patterns is used by flying insects to orient and course correct in their environment (Kennedy, 1940; David, 1986). The infrared transmitting plastic material blocks all visible light (< 780 nm) from the white LEDs and so appears opaque to human observers and mosquitoes, providing contrast against the moonlight-equivalent illumination from the floor. However, the material allows 90% of infrared light in the range 850 to 2000 nm to pass through. The cameras, detecting this infrared light, record the markers as only faint grey shadows (Figure 3.4). Therefore, mosquitoes are provided with a suitable visual environment, but are still discernible in silhouette when flying over markers, leaving tracking capability unhindered.





**Figure 3.4 Aerial view of black infrared transmitting floor markers as captured by infrared-sensitive cameras.** (A) Daylight-equivalent laboratory lighting and (B) white plus infrared LEDs used in experiments. Mosquito silhouettes could be tracked when flying over the markers, as the markers allow infrared light to pass through, so appear only faint grey; mosquitoes block all visible and infrared light, so appear in silhouette throughout the arena.

### 3.4 Three-dimensional data analysis

A custom analytical library was written in Python for the purposes of analysing track data output by TrackIt3D. This utilised existing Python libraries with additional calculations for track analysis (Appendix A).

### 3.5 Mosquito colony

The colony of *A. gambiae* s.s. (M molecular form, now known as *An. coluzzii* Coetzee & Wilkerson **sp. n.**; Coetzee et al, 2013) was established at the Natural Resources Institute, University of Greenwich, Kent, U.K. in 2009 with individuals from laboratory colonies established in Burkina Faso (Institut de Recherche en Sciences de la Santé) from wild mosquitoes caught in Bobo Dioulasso, Burkina Faso, and identified by polymerase chain reaction (Favia et al., 2001).

Mosquitoes were maintained in a climate controlled insectary at  $26 \pm 2^\circ\text{C}$  and  $60 \pm 10\%$  RH, in an L:D 12:12 h light-dark cycle. Cages of 5 to 10 day

old mosquitoes were offered a human blood meal for 15 min at the start of the scotophase for two consecutive days. Eggs were laid on wet filter paper discs and transferred to trays of water for hatching, whereupon larvae were fed powdered baby rice and ground fish flakes (Tetramin, Tetra Werke, Germany) as needed. Pupae were removed daily and placed in 10 cm dia. water dishes inside adult cages prior to emergence. Adult cages were 30 x 30 x 30 cm metal frames covered with medical tube gauze. Adult mosquitoes had access *ad libitum* to a solution of 10% glucose held in a wick feeder (Benedict, 2008).

## 4 MODIFICATION OF SPONTANEOUS ACTIVITY IN HOST-SEEKING *ANOPHELES GAMBIAE* PRESENTED WITH HOST-ASSOCIATED ODOURS (HAWKES ET AL., 2012<sup>\*</sup>)

### 4.1 Background

Many aspects of mosquito physiology and behaviour are governed by an endogenous clock that can synchronize with external entraining agents, particularly the light cycle. This mechanism of time-keeping leads to underlying rhythms of behaviour, as can be observed in the pattern of spontaneous flight activity of mosquitoes under constant conditions (i.e. in the absence of any changes in environmental stimuli). Regularly timed activities observed in mosquitoes under natural conditions include mating (Jones & Gubbins, 1978), oviposition (Sumba et al., 2004; Fritz et al., 2008) and biting (Reisen & Aslamkhan, 1978). Little is known, however, about how exogenous stimuli, such as host-associated cues, interact with the underlying pattern of spontaneous flight activity to determine the probability that a mosquito will respond to host cues at particular times of day.

Physiological condition has been shown to affect the pattern of spontaneous flight activity in different mosquito species. Virgin females of both *An. gambiae* (Jones et al., 1974) and *Cx. quinquefasciatus* (Jones & Gubbins, 1979) show a major peak of activity at dusk and a minor peak at dawn, and total inactivity during the photophase (subjective day) that coincide with the activity pattern of males, hence this activity in virgin females is thought to be associated mostly with mating. Inseminated females of *An. gambiae*, however, exhibit a broad peak of activity throughout the scotophase,

---

<sup>\*</sup> This study is published in *Physiological Entomology* and was conducted in collaboration with Dr Stephen Young and Dr Gabriella Gibson. FH devised the experiment and apparatus, conducted experiments, analysed data and wrote the manuscript; SY contributed to data analysis; GG devised the experiment and apparatus and contributed to the manuscript.

coinciding with a shift in behaviour toward host-seeking under natural conditions (Jones & Gubbins, 1978). This change in activity pattern has been shown to be associated with hormonal changes in the female caused by introduction of a male accessory gland fluid into virgin female *Cx. quinquefasciatus* at insemination. In the case of changes in physiological state between blood-seeking and oviposition, it is found in *Anopheles stephensi* Liston (Diptera: Culicidae) that the pattern of activity is reversible; having oviposited, parous females resume the activity pattern characteristic of inseminated nulliparous females (Rowland, 1989).

More subtle changes in activity patterns are also reported. Bockarie et al. (1996) find that parous females of *Anopheles punctulatus* Doenitz (Diptera: Culicidae) and *An. gambiae* tend to bite later in the night than nulliparous females (i.e. after 22:00 hr), and that mosquitoes infected with sporozoites of the malaria parasite *Plasmodium falciparum* also tend to bite later at night. These changes in biting habits hint at the potentially complex interactions between endogenous rhythms, physiological state and external stimuli.

Brady (1974) proposes that circadian changes in central excitability may be the underlying neurophysiologic basis of behavioural rhythmicity. External stimuli are generally thought to be detected by sensory systems irrespective of time of day. The processing of external and internal stimuli in the brain, however, depends on time of day and leads to temporally variable messages to motor systems, as evidenced by species-specific adaptations for activity at particular times of day. For example, even though cues from human hosts are present throughout the diel, *An. gambiae* females respond to these cues mainly at night, which is advantageous for a variety of reasons, e.g., there is a reduced risk of dehydration, and the human host is most quiescent and least likely to exhibit defensive behaviour against mosquito bites. The evolution of temporal patterns of central responsiveness would appear to have contributed to the evolution of species-specific physiological and behavioural adaptations to a wide range of endogenous and exogenous factors that vary across the diel (Gibson & Torr, 1999). Little is known,

however, about how the pattern of spontaneous activity itself is affected by the intermittent and unpredictable presence of host cues once the threshold of responsiveness declines. There are practical implications of this question: How precisely does the design of experiments to test responsiveness of *An. gambiae* to putative attractant or repellent chemicals need to take into account the time of day assays are conducted? Also, to what degree do endogenous changes in levels of responsiveness across the diel have an effect on the variability of bioassay data?

There are indications from field studies that malaria vectors may have shifted the timing of biting to earlier in the night in places where insecticide-treated bed nets have been used extensively over a number of years (Reddy et al., 2011; Russell et al., 2011). If this shift is due to a change in the endogenous pattern of responsiveness to host cues, a simple circadian activity actogram bioassay could provide a rapid means of detecting this form of behavioural avoidance of lethal doses.

Barrozo et al. (2004b) describe the relationship between daily rhythms of host, vector and parasite as a 'complex circle of temporal interactions'. Yet research has tended to neglect the effect of diel variation in the presence of host cues on modulating behavioural periodicities in mosquito species. Such relationships between host cues and circadian patterns of activity are observed in other species; for example, an endogenous circadian rhythm of orientation towards CO<sub>2</sub> exists in the haematophagous bug *Triatoma infestans* Klug (Hemiptera: Reduviidae), although this only corresponds to two short bursts at the beginning and end of the scotophase, rather than to the entire duration of host cue availability (Barrozo et al., 2004a). The complex interaction between endogenous responsiveness and the presence of external stimuli may be part of the process by which different vector species have segregated host-feeding behaviour temporally across the day (Gibson & Torr, 1999).

It is also suggested that by varying responsiveness to particular exogenous sensory inputs, the structuring of complex behaviours could be made more efficient (Bernays & Singer, 1998). Given the high human blood index recorded for *An. gambiae* over much of its distribution, including in Burkina Faso where the experimental colony mosquitoes originated (Costantini et al., 1998b), it seems plausible that the intensity of host-seeking activity in this species could be modified by the presence of host-associated odours, including carbon dioxide, to maximize exploitation of a specific food resource. This experiment seeks to determine whether the behavioural periodicity of nocturnal activity in host-seeking (mated) *An. gambiae* is modified by the presence of exogenous host-associated olfactory stimuli.

## **4.2 Materials and methods**

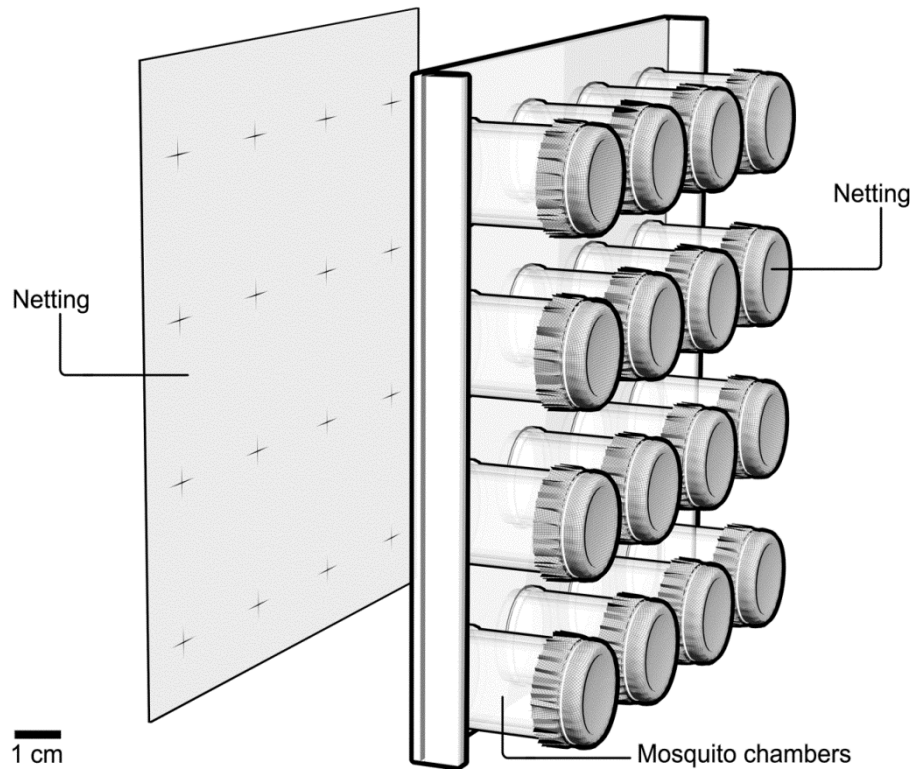
### *4.2.1 Mosquitoes*

Experimental *An. gambiae* s.s. (M molecular form) from the laboratory colony of the Natural Resources Institute were used in the present assay and were reared as described in Chapter 3.5.

### *4.2.2 Holding array and wind tunnel arena*

The holding array consisted of a 4 x 4 array of 16 chambers, each consisting of a transparent Perspex cylinder (3.5 cm dia., 4.5 cm long and separated from each other by 2 cm) held in a wood and Perspex framework (30.5 cm wide x 24.5 cm high x 0.5 cm deep). The chambers were sealed at both ends by mosquito netting so that the individual mosquitoes placed in each chamber were exposed simultaneously to a flow of moving air (Figure 4.1). Each mosquito was inserted into its own chamber by aspirator through a slit in the netting. The holding array was placed inside the wind tunnel arena described in Chapter 3.2 at the downwind end, with a continuous flow of clean air ( $8.0 \text{ cm s}^{-1}$ ) at  $25 \pm 2^\circ\text{C}$  and  $65 \pm 5\% \text{ RH}$  (see below). Illumination visible to mosquitoes consisted of a net of 208 clear white light LEDs to provide starlight-equivalent light levels (Brady, 1987). Based on carbon

dioxide plume measurements (Chapter 5.2.3), odour variations between individual chambers were deemed to be minimal.



**Figure 4.1 Exploded view of holding array, showing sixteen chambers that hold individual mosquitoes.** Mosquitoes were held in their chambers by a netting enclosure at one end and a sheet of netting with a slit positioned over each chamber at the opposite end.

#### *4.2.3 Video recording of activity*

An analogue high resolution camera (SHC-735P, Samsung, Korea), fitted with a 1/3" infrared corrected, C mount varifocal lens ( $f:1.0$ ) with auto-iris (SLA-3580DN, Samsung, Korea), was mounted on a tripod approximately 30 cm from the holding array on the downwind side. The camera was focused manually on the holding array and capable of operating at 0.01 Lux (approximate ambient light intensity in the wind tunnel) with additional illumination for the camera provided by background lighting consisting of 10

light emitting diode (LED) arrays (3.6 W) emitting infrared light at 880 nm (matching the peak sensitivity of the camera). This background light provided sufficient contrast against which mosquitoes could be seen in silhouette. The camera signal was fed into a digital video recorder (SRD-470D, Samsung, Korea) and transferred by USB flash drive to a desktop PC for playback and analysis.

#### *4.2.4 Odour treatments*

The holding array was placed at the downwind end of the wind tunnel flight arena described in Chapter 3.2.

##### *Host odour*

The odour of human feet has been shown to be attractive preferentially to both *An. gambiae* (De Jong & Knols, 1995) and *Cx. quinquefasciatus* (Oduola & Awe, 2006), so socks that had been worn on the feet of a volunteer were used as a source of attractant host odour. The volunteer abstained from consuming alcohol, strong tasting or spicy foods and from using perfumed soaps or cosmetics in the 24 h prior to the experiment to reduce daily variation in the composition of host odours. After washing feet in a non-perfumed soap, a 100% cotton sock was worn by the volunteer for 12 consecutive hours. It was then sealed in a zip lock bag for 24 h prior to use in the assay, thus allowing microflora to proliferate, as these cultures are implicated in producing the odours which attract host-seeking mosquitoes (Verhulst et al., 2009). As there is variation in the relative attractiveness of human odours from different individuals (Qiu et al., 2006; Knols et al., 1995), the same volunteer was used in all experiments.

##### *Carbon dioxide*

Either constant or pulsed carbon dioxide (4.8%) was added to human host odour to test the effect on the daily activity rhythm of individual, isolated female mosquitoes.



Pure carbon dioxide from a pressurised cylinder ( $200 \text{ mL min}^{-1}$ ) was mixed with air drawn by a pump from the conditioned air at the upwind end of the wind tunnel through a sintered dip tube into a 250 mL Dreschel bottle containing 150 mL distilled water to help mix the air and carbon dioxide. This source of  $\sim 4.76\%$  carbon dioxide was released from a delivery chamber at the upwind end of the wind tunnel at a flow rate of  $5 \text{ L min}^{-1}$ , either continuously, or pulsed, as required.

Constant carbon dioxide was presented by allowing the carbon dioxide blend to be present for the 15 min duration of the treatment assays. Pulsed carbon dioxide was presented for 15 min assays as 5 s bursts of the carbon dioxide blend followed by 25 s with only clean conditioned air pumped through the odour delivery chamber (Healy and Copland, 1995). Pulsing was conducted manually by opening and closing a needle valve that regulated carbon dioxide flow.

The human odour source (worn socks) was placed in a brass mesh dish immediately downwind of the carbon dioxide source in both odour treatments. For the control treatment, clean air only was pumped continually through the odour delivery chamber into the arena for the duration of the 15 min treatment assay at  $5 \text{ L min}^{-1}$ , with a clean sock in the brass dish.

#### *4.2.5 Experimental procedure*

Three groups of 16 mosquitoes were used to test the effect of an odour treatment on activity at hours 3, 6 and 10 of the scotophase. The behaviour of each treatment group was recorded for the first 15 min of hours 3, 6 and 10 under the same constant conditions of clean air flowing at  $8.0 \text{ cm s}^{-1}$  (pre-treatment control), followed by another 15 min while exposed to one of three treatments: treatment group 'constant' was exposed to host odour plus constant carbon dioxide, treatment group 'pulsed' was exposed to host odour plus pulsed carbon dioxide and treatment group 'control' was exposed only to clean air throughout. Hence, the behaviour of each treatment group was

video recorded for the first 30 min of hours 3, 6 and 10 according to the following protocol.

Between 16 and 18 h prior to the assay, 5 to 10 day old females were removed from adult cages via an aspirator and transferred to individual chambers in the holding array. Access to 10% sugar solution was provided on filter paper wicks (5 mm x 15 mm) in each holding chamber. The holding array was left in the climate controlled insectary room until 1 h before each assay began. Surgical gloves were worn when handling test mosquitoes and equipment to limit exposure to additional host odours.

At the onset of the scotophase, the holding array for a given treatment group was put in position in the wind tunnel to allow the mosquitoes to acclimatise. At the start of hour 3, the behaviour of the 16 mosquitoes in the holding array was recorded on video with only clean air present for 15 min (pre-treatment control), followed by 15 min with one of the three treatments. At the start of hours 6 and 10 the same sequence was recorded on video; 15 min pre-treatment in clean air, followed by 15 min with treatment air. Each mosquito was its own experiment-control, in the sense that in each observation hour the first 15 min of its behaviour was recorded before any treatment odours were released. Recording pre-treatment levels of activity provides a way to monitor the spontaneous activity of individuals following prior treatment periods. The 'control' treatment group was observed for two 15 min periods each observation hour, exposed to only clean air throughout.

#### *4.2.6 Data analysis*

Video recordings were reviewed using the computer programme VLC Media Player (VideoLAN), which allowed for ease of analysis, moving back and forth in slow motion. Records were scored by manual observation; the activity of individual mosquitoes was given a score for each 0.5 min time bin across the two 15 min recording periods per hour (i.e. 60 bins for each observation hour; 30 bins for the 15 min pre-treatment control recording plus

30 bins for the treatment recording). Activity was divided into four categories: 'resting' = mosquito remains stationary for  $\geq 2$  s, 'walking' = mosquito walks over the surface of the net or the inside of the chamber for  $\geq 2$  s, 'jumping flight' = mosquito flies for  $< 2$  s, and 'prolonged flight' = mosquito flies for  $\geq 2$  s. A fifth category of 'not visible' was assigned to mosquitoes that could not be seen owing to image distortion caused by the viewing angle of the video camera; this accounted for  $< 5\%$  of all possible categories. If a mosquito was observed to exhibit a category of behaviour at least once within a 0.5 min bin, it was given a score of 1 for that category. In principle, for any 0.5 min bin, a mosquito could exhibit anywhere between one and all five categories. Therefore, the maximum score for each of the five activities in each 15 min observation period was 30.

### *Statistical analyses*

The walking, jumping and flying scores were strongly '0' inflated and over-distributed, so non-parametric tests were used for these data. However, difference scores between pre-treatment and treatment periods showed symmetrical distributions and ANOVA residuals were satisfactory, and were used, therefore, to assess the effect of 'treatment' and 'hour' on mosquito behaviour.

The pattern of activity during pre-treatment periods was analysed to determine if there were significant differences between the three groups of 16 mosquitoes in the levels and timing of activity throughout the scotophase. A Friedman two-way non-parametric analysis of variance test was used to test for significant effects of the hour of the scotophase on pre-treatment activity scores, followed by a Wilcoxon test, with Bonnferroni correction for multiple comparisons, to test for significant differences between hour means.

To assess the effect of treatments on the pre-treatment levels of spontaneous activity, the mean difference between pre-treatment and treatment scores were calculated for walking plus jumping scores for each

mosquito for each hour (based on data columns in Figure 4.3). These difference scores were subjected to an ANOVA using a mixed-effect model (with mosquito replicates as a random effect) to test the effects of 'hour' and 'treatment'. Both the raw difference scores and the ANOVA residuals had a symmetrical distribution. Related sample *t*-tests were used to compare the effects of treatments between hours. All statistical tests were performed in R (R Development Core Team, 2010).

### 4.3 Results

#### 4.3.1 *Spontaneous activity in pre-treatment (constant conditions) periods*

The overall pattern of activity of mated *An. gambiae* s.s. females across the scotophase during the 15 min pre-treatment periods with clean air only (Figure 4.2) shows a broad distribution of activity across the scotophase, with a significant effect of 'hour' (Friedman chi-squared = 12.7883, d.f. = 2,  $P < 0.005$ ). There was no significant difference in level of activity between hours 3 and 6 (Wilcoxon,  $V = 304.5$ ,  $P = 0.23$ ), but significantly less activity in hour 10 than in hours 3 or 6 (Wilcoxon; hour 3 and hour 10,  $V = 399.5$ ,  $P = 0.005$ ; hour 6 and hour 10,  $V = 342$ ,  $P < 0.001$ ). This is consistent with previous findings for the pattern of spontaneous activity of this species under constant environmental conditions (Jones & Gubbins, 1978).

#### 4.3.2 *Effect of treatments on activity scores*

Figure 4.3 shows the effects of treatment on activity scores across all three time periods. Overall, it is clear that mosquitoes spent most of the time at rest (top row). Constant and pulsed treatments, however, caused a notable decrease in resting, and an increase in walking and jumping in hours 3 and 6, respectively, although it was not possible to determine the orientation of these responses. On this basis, walking and jumping were subjected to statistical analysis (see below).

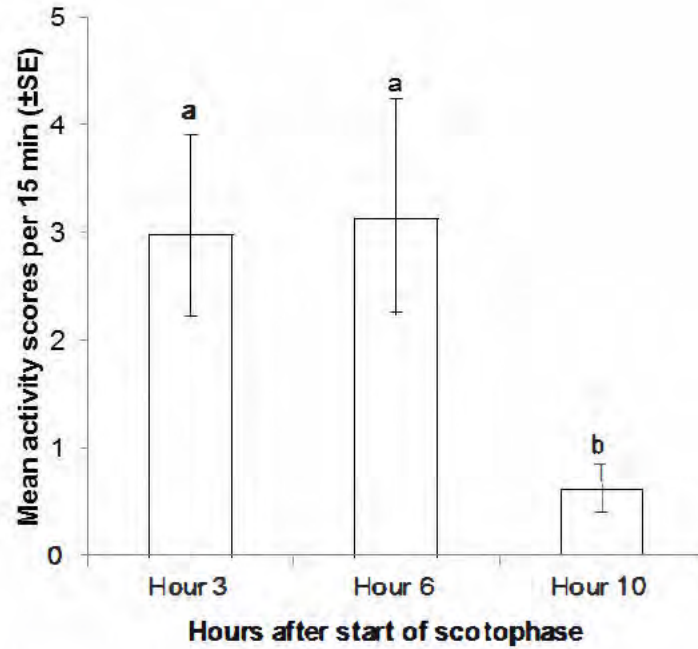
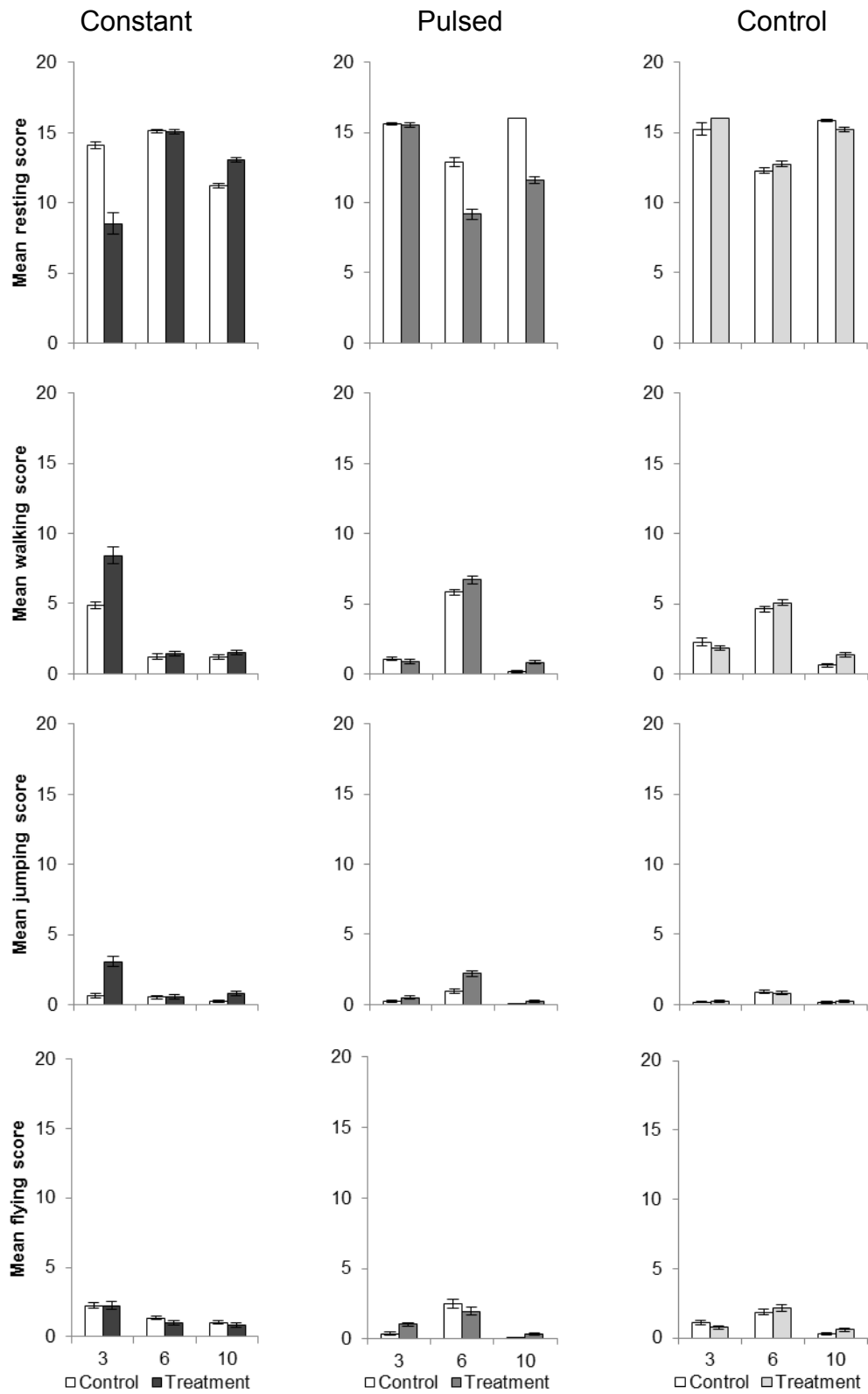


Figure 4.2 Pre-treatment levels of movement-related activity for female *An. gambiae* across the scotophase (score of '1' for each 30 s period with any amount of walking, jumping or flying.) Data are pooled across all three treatment groups (16 mosquitoes per group). Each column represents data for N = 48 female mosquitoes over 15 min observation period. Data are the back-transformed means of log-transformed scores (+1), with maximum score = 30, ± back-transformed SE. Different letters denote significant differences between hours (Wilcoxon,  $P < 0.01$ ).

Figure 4.3 (overleaf) Mean activity scores for female *An. gambiae* for resting, walking, jumping and flying for each treatment group, recorded at hours 3, 6 and 10 of the scotophase. Each column represents activity levels of N = 16 female mosquitoes over 15 min pre-treatment period (white columns), followed immediately by 15 min treatment period: constant carbon dioxide plus host odour (dark grey), pulsed carbon dioxide plus host odour (grey) and a treatment-control of no added host cues (light grey). Data are back-transformed means of log-transformed scores (+1), with maximum score = 30, ± back-transformed SE.



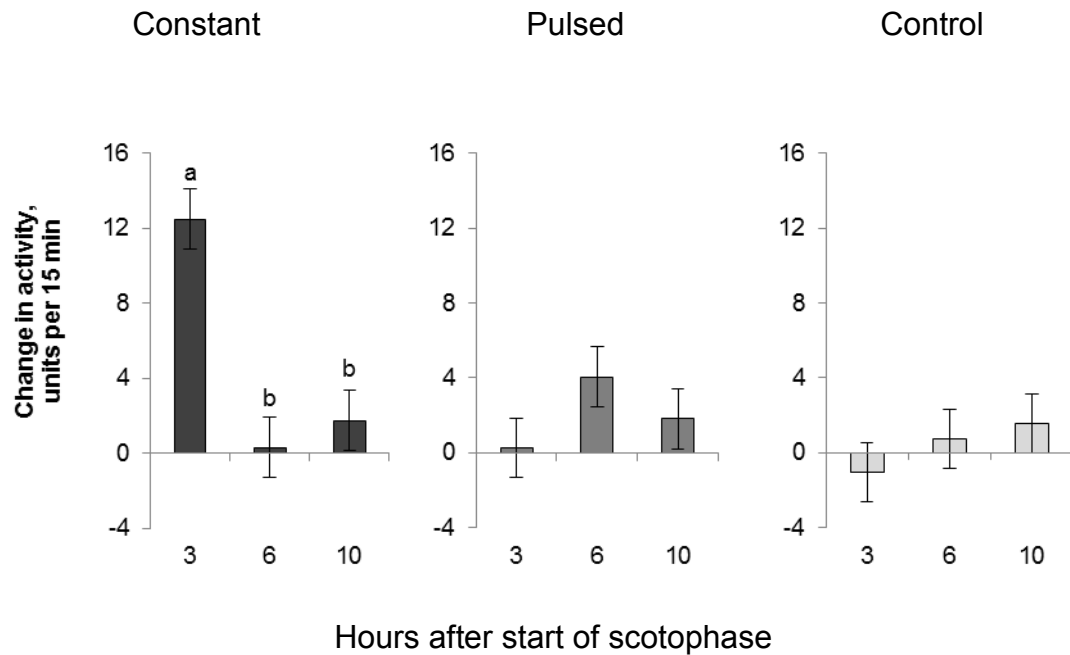
Hours after start of scotophase

### *Differences between treatment and preceding pre-treatment periods*

There is considerable variability in pre-treatment activity between treatment groups (Figure 4.3), with the constant treatment group showing high levels of spontaneous pre-treatment activity. Variability in activity levels between groups of mosquitoes is not unusual, and the aim of the experiment was to measure changes in behaviour between pre-treatment and treatment periods. Accordingly, the use of difference measures between treatment periods and the immediately preceding pre-treatment periods appropriately shifts the emphasis from absolute levels of activity to relative changes in activity level.

Figure 4.4 shows the mean change in activity level between each treatment group and its pre-treatment control. Overall, 'hour' had no significant effect on the mean difference scores, but 'treatment' had a significant effect (Mixed-effect ANOVA,  $F = 6.00$ , d.f. = 2,39,  $P < 0.01$ ), and the interaction between 'treatment' and 'hour' was highly significant ( $F = 8.94$ , d.f. = 4,39,  $P < 0.0001$ ). The change in activity level associated with the constant treatment was significantly greater in hour 3 than in hour 6 (Related sample  $t$ -tests,  $t = 4.44$ , d.f. = 15,  $P < 0.001$ ) or hour 10 ( $t = 3.48$ , d.f. = 15,  $P < 0.01$ ). There was a tendency for the change in activity level associated with the pulsed treatment to be greater for hour 6 than hour 3, although this was not significant ( $t = 1.98$ , d.f. = 15,  $P = 0.066$ ), and the control treatment had no significant effect on activity levels, as expected since it represented changes in activity levels between two contiguous 15 min periods under constant (clean air) conditions.

In summary, constant carbon dioxide plus host odour increased activity significantly above spontaneous levels, but only in hour 3 of the scotophase. Pulsed carbon dioxide plus host odour did not increase activity.



**Figure 4.4** Effect of host cues on the mean change in level of all movement-related activities (control score – treatment score) for constant carbon dioxide plus host odour (dark grey), pulsed carbon dioxide plus host odour (grey) and a treatment-control of no added host cues (light grey). Mean changes in level of activity  $\pm$  SE, N = 16 female mosquitoes per column. Different letters denote significant differences between hours in the constant treatment group (related sample *t*-tests,  $P < 0.01$ .)

#### 4.4 Discussion

*An. gambiae* is a nocturnal blood-feeder that host-seeks actively during the scotophase (Clements, 1992). However, it is clear from the experimental results presented here that constant carbon dioxide plus host odour has a significant effect on the spontaneous activity of mated females early in the night. The functional basis for an activity pattern that increases responsiveness to olfactory stimuli associated with a host at particular times of the day may be linked to an increased likelihood of success in locating the source of odour and obtaining a blood meal.

Jones and Gubbins (1978) report that mated female *An. gambiae* exhibit greater activity overall across the scotophase compared to virgin females, but with much reduced peaks. The presence of constant carbon dioxide plus



host odour, however, seems to have an effect on this pattern of activity. The high activity scores seen in hour 3 of the scotophase may represent an olfactory-mediated response that increases the level of activity above that of spontaneous activity when carbon dioxide and/or host odour are detected above a certain threshold level. Although diel rhythms of chemoreceptor sensitivity to host odours are observed in *Glossina morsitans morsitans* Westwood (Diptera: Glossinidae) (van der Goes van Naters et al., 1998), this is not seen in mosquitoes (Bowen et al., 1992). It is more likely that the threshold of central nervous system responsiveness is altered throughout the day, increasing the likelihood of a motor response to host stimuli at times of day when a given species is best adapted to succeed (Brady, 1974).

Githeko et al. (1996) report that the main malaria vectors start biting people just after 20:00 h, although 83% of females are caught biting between 01:00 and 06:00 h, based on hourly human-biting rates in Miwani, Kenya. Recent reports from other test sites suggest earlier vector activity following the introduction of bed nets (Reddy et al., 2011; Russell et al., 2011). These findings, together with the results of the current study, suggest that *An. gambiae* are primed for a high and immediate level of responsiveness to host odours early in the night, provided they receive a stimulus that is strong enough to breach the threshold required to induce activity. Subsequent behaviour (alighting on and biting a host) follows on from this. As optomotor-guided upwind anemotaxis is assumed to be the first phase of host-seeking (Cardé & Willis, 2008), responsiveness to odours may be greater in the early phase of the night, to allow broad odour-mediated orientation, followed by a reduction in responsiveness to these cues (although only excitation, not orientation, was recorded in this study). A subsequent heightening of sensitivity to other host cues that may provide better directional cues at close range (such as visual or thermal stimuli), or intermittent stimulation by a single host breathing, similar to the pulsed carbon dioxide plus human odour treatment that increased activity at hour 6 in the present study, may allow for close-range orientation and biting (Cardé & Gibson, 2010; Gibson & Torr, 1999). A model in which heightened sensitivity to olfactory cues early in the

process of host-seeking and under endogenous control thus fits well with the observed sequence of behaviours that leads to host location.

Ongoing spontaneous activity observed in *An. gambiae* when not presented with host cues, as seen in this study and by Jones et al. (1972) and Jones and Gubbins (1978), may be beneficial for those individuals that have not been exposed to a host odour plume and are therefore unlikely to have made significant movements toward potential hosts to begin a more active phase in which they increase their chances of encountering an odour plume and consequently, a host. Interestingly, the constant treatment group show lower activity levels in hour 6 than might be expected from published patterns of mid-night spontaneous activity (Jones et al., 1972; Jones & Gubbins, 1978); it is possible that although sugar feeders were available throughout the assay, their high level of activity in hour 3 may have influenced their later performance.

Recent work profiling the genomic basis of circadian physiology and behaviour in *An. gambiae* finds that 15.8% of the insect's gene set is under circadian control, including genes related to olfaction (Rund et al., 2011). This suggests a possible means for circadian regulation of responsiveness to olfactory cues. Identifying the precise mechanisms by which changes in sensitivity to host cues are mediated might provide insights into the behaviour of host-seeking mosquitoes and, furthermore, means by which such behaviour may be inhibited.

Behavioural periodicities must offer adaptive advantages, and the ability to detect and locate host-associated cues better at particular points across the scotophase may result in efficiency savings and improved reproductive success that proffer such advantages to host-seeking mosquitoes. These mechanisms warrant further investigation and have the potential to direct temporally phased vector control strategies for *An. gambiae*, as earlier host-seeking activity induced by host cues could create a window of exposure before people go to bed and receive the protection of bed nets.

## 5 CHARACTERISING HOST-SEEKING FLIGHT IN *ANOPHELES GAMBIAE* IN THE PRESENCE AND ABSENCE OF HOST ODOUR

### 5.1 Background

In the malaria mosquito *An. gambiae*, host-seeking behaviour is an important part of the species' life cycle, which not only influences the reproductive success of the individual, because females require a blood meal to develop their eggs, but also impacts the nature of disease transmission, because it ultimately defines how vector and host come into contact. The endogenously and exogenously controlled behavioural rhythm of activity, discussed in Chapter 4, activates *An. gambiae* to search for a host during crepuscular/nocturnal periods. Once activated, females must integrate relevant information from both the host and the surrounding environment over a range of spatial scales and react to these cues in such a way as to bring them to the body of a potential host (Cardé & Gibson, 2010).

In the first instance, mosquitoes take flight into the surrounding air, which may or may not contain suitable olfactory cues from potential hosts to allow immediate plume-following. Anemotaxis is a movement oriented with respect to a current of air (Vickers, 2000) and experimental and theoretical work has produced a variety of hypotheses suggesting the most efficient direction in which insects should move with respect to the wind if they are to successfully locate an odour plume. Geometrical modelling has proposed that downwind flight offers the most energy-efficient plume-seeking strategy when traversing winds with more than 30° variation in direction (Sabelis & Schippers, 1984). However, after Gillies and Wilkes (1974) initially inferred downwind flight from field catches of *Mansonia* (Diptera: Culicidae) species, their conclusion was revised to reflect the fact that the design of their field traps did not adequately monitor approach direction and so mosquitoes were, in fact, largely thought to be flying upwind, not downwind (Gillies & Wilkes, 1978).

Conversely, upwind flight in clean *and* odour-laden air is frequently reported for *An. gambiae* (Takken & Knols, 1990; Beeuwkes et al., 2008; Spitzen et al., 2008) and other mosquito (Pile et al., 1991; Pile et al., 1993; Cooperband & Cardé, 2006; Lacey & Cardé, 2011) and insect species, including tsetse flies (Colvin et al., 1989). It has also been suggested as an optimal plume-seeking strategy based on geometrical modelling (Dusenberry, 1990). In field experiments, Cardé et al. (2012) found that plume-seeking flights in a diurnal moth were randomly distributed in all possible directions, although as crosswind represents two directional orientations with respect to a heading, they concluded that 'random' flights were, in fact, more frequently crosswind, whilst Cummins et al. (2012) developed a model indicating crosswind flight is the orientation direction by which mosquitoes will most likely encounter a host odour plume. In all directions, mosquitoes tend to fly within the atmospheric boundary layer and fly faster than the wind speed, although they can be swept along in the direction of the wind at higher elevation (Service, 1980).

Once an odour plume has been encountered, it is generally accepted that flying insects will fly upwind, as this is likely to be where the odour source lies (Vickers, 2000). Different species may exhibit different means of following the plume and research over the last decade has elucidated some of this behaviour in mosquito species. Beeuwkes et al. (2008) conducted a study of the flight behaviours of *An. gambiae* s.s. in relation to a plume of host odour (from a worn sock) and synthetic plumes of ammonia (at concentrations of 136 and 1363 ppm) and lactic acid, individually and in combination. Notwithstanding a very low response rate (14 out of 245 females, across all treatments, with sufficient plume contact for analysis), they found females reduce their flight speed and their track angle when inside an odour plume, and flight speed is further reduced as individuals approach the odour source. Flight paths outside the plume are described as 'rather straight', without providing any more details. Dekker and Cardé (2011) observed crosswind moth-like casting in free-flying *Ae. aegypti* that had lost contact with an odour plume. In common with *An. gambiae*, *Cx. quinquefasciatus* fly more slowly

inside odour plumes, and more slowly still when approaching odour sources; however, *Cx. quinquefasciatus* fly more directly upwind in clean air or carbon dioxide than when flying in foot odour plumes; foot odour results in less direct flight paths (Lacey & Cardé, 2011). A slower flight speed inside an odour plume is likely to reduce the likelihood of irreversibly overshooting the boundaries of the plume and may also allow finer spatial sampling of the temperature and humidity gradients associated with potential hosts at close range.

The olfactory-driven directional responses of *An. gambiae* are in broad accordance with more detailed reports of the moment-to-moment responsiveness of female *Ae. aegypti* responding to plume boundaries. This species also orientate more directly upwind within 300 ms of entering an odour plume from a human hand, then fly with a more crosswind bearing 300 ms after leaving the same plume (Dekker et al., 2005) in a manner similar to the surge and cast model proposed by Baker (1990) for moth pheromone orientation. Unlike male moths tracking female pheromone filaments, which more than double their speed after plume contact (Mafra-Neto & Cardé, 1998), there is no reported difference in speed of *Ae. aegypti*, either inside or outside of plumes, although overall flight speed increases with increasing odour and carbon dioxide concentrations (Dekker et al., 2005). This raises the question of how well it was possible to map the precise boundaries of the plume structure in this study; if speed was greater in odour treatments, to a similar extent both inside and outside the plume boundary, then it seems likely that the greater speed outside of the host odour plume may, in fact, be a result of olfactory stimulation by 'stray' plume odours, as no other stimuli were present to account for behavioural changes outside the plume. Nonetheless, an increase in speed upon odour contact may be better suited to the day time activity of *Ae. aegypti*, as the well-defined visual properties of potential hosts may overtake olfactory stimuli as the driving orientation mechanism.

Many studies exploring mosquito anemotaxes, plume-seeking and plume-following behaviour have utilised carbon dioxide alone or in combination with extracts of human odour, such as volatiles collected on socks worn by human volunteers, as 'attractive' odours (Cooperband & Cardé, 2006; Beeuwkes et al., 2008; Spitzen et al., 2008; Dekker & Cardé, 2011). Alternatively, odour sources are often presented with experimentally controlled physical properties, which include manipulating them into filamentous, ribbon-like, turbulent or homogenous plumes (Geier et al., 1999; Dekker et al., 2005; Dekker & Cardé, 2011). Detailed quantification of flight behaviour in response to a whole host is therefore lacking in the existing body of research, both in terms of the plume's olfactory profile (which will include skin and microflora volatiles and breath) and the physical structure of the plume (which will be structurally irregular, heated, volatilised and humidified by the body of the host). Furthermore, methods of analysis have tended to be drawn from those used to describe moth pheromone following, and whilst this provides an insight into some elements of olfactory navigation in mosquitoes, particularly as they enter and exit discrete plumes, the evolutionary differences between host-seeking and mate-seeking require additional ways of exploring mosquito flight behaviour.

As described here, published studies have demonstrated the existence of similarities and differences in some of the flight characteristics of mosquito species, and orientation strategies analogous to the casting model of moth flight have been suggested for *Ae. aegypti* and, tentatively, for *An. gambiae*. However, there remains a paucity of data pertaining to *An. gambiae* s.s., possibly owing to the greater technical challenge of recording the activity of this nocturnal species. This experiment therefore sets out to quantify the free-flight behaviour of *An. gambiae* in response to a flow of clean air, with a view to identifying potential means by which this species searches for an odour plume, and in air containing olfactory cues from a whole host, to characterize the close range behaviours that are employed to navigate through the odour plume in search of the source of odour.

## 5.2 Materials and methods

### 5.2.1 Mosquitoes

Female *Anopheles gambiae* used in experiments were reared as described in Chapter 3.

### 5.2.2 Wind tunnel and flight arena

Experiments were carried out in the wind tunnel and flight arena described in Chapter 3, using the same environmental parameters as listed.

### 5.2.3 Odours

Two odour environments were tested: a treatment of whole host odour with additional carbon dioxide and a control of clean air.

#### *Whole host odour with additional carbon dioxide*

A human volunteer was positioned downwind of the laminizing screen, so that her upper body (waist and above) was centred in the odour delivery chamber, with her mouth positioned ~ 35 cm above the flight arena floor. The volunteer was sealed into the chamber at the waist with a tight-fitting opal Perspex extension to the wind tunnel floor. To reduce daily variation in host odour composition (Qiu et al., 2006), the same volunteer was used in all host odour assays, and in the 24 h before the experiments abstained from consuming alcohol and strong tasting foods and from using perfumed soaps and cosmetics to reduce the chances of variable mosquito behaviour caused by odours not normally associated with the human host.

Carbon dioxide is known to be a major attractant to human hosts by *An. gambiae* (Costantini et al., 1996). Additional carbon dioxide was provided as described in Chapter 4, at 4.8% concentration. Silicone tubing carried the carbon dioxide well-mixed with clean air into the odour delivery chamber, where it was released directly adjacent to the human volunteer's mouth.

### *Carbon dioxide plume structure*

Structure and variability in the carbon dioxide plume created by the human volunteer with additional carbon dioxide was recorded at 5 cm intervals over a cross-sectional grid across the flight arena (50 cm wide x 35 cm height) ~ 50 cm downwind of the carbon dioxide source at the centre of the 3D field of view of the two video cameras. Readings in parts per million carbon dioxide concentration (EGM-4 Environmental Gas Monitor, PP Systems, UK) were taken for 1 min at each interval of the grid, at a rate of 37 measurements per minute, and average and standard error values computed. The same procedure was followed for clean air to ascertain background carbon dioxide concentration.

At this point in the wind tunnel, the carbon dioxide plume had a relatively sharp boundary (see Figure 5.1, circle radius ~ 25 cm; nowhere outside this boundary was carbon dioxide > ~ 1500 ppm). This implies that the carbon dioxide plume expanded from a circle of about 5 cm where it was created by the host, to about 25 cm at a point 50 cm downwind, so appears to have expanded to create a cone of relatively high concentration carbon dioxide. The highest mean concentrations of carbon dioxide were found at the points closest to the height of the release point of the human volunteer's breath and the additional flow of 4.8 % carbon dioxide (Figure 5.1). The mean concentration over the whole grid was  $1060 \pm 30$  ppm carbon dioxide, although there was spatial and temporal variability in instantaneous concentration. Over the 1 min sampling period, carbon dioxide ranged between 791 and 3462 ppm at the point near the centre of the plume with the highest mean concentration, and from 776 to 1418 ppm at the point with lowest mean concentration, which was located near the edge of the field of view.

Background levels, with no human or artificial carbon dioxide released at the upwind end, ranged from 439 to 511 ppm carbon dioxide over the area sampled, and from 410 to 743 ppm over the 1 min sampling period at the point with the highest concentration. The mean background concentration of



carbon dioxide was  $460 \pm 5$  ppm. The global atmospheric concentration of environmental carbon dioxide is estimated at around 380 ppm (Guerenstein & Hildebrand, 2008); the higher than average concentration of carbon dioxide may be attributable to the laboratory's situation within a heavily urbanised area and its adjacency to a coal-fired power station.

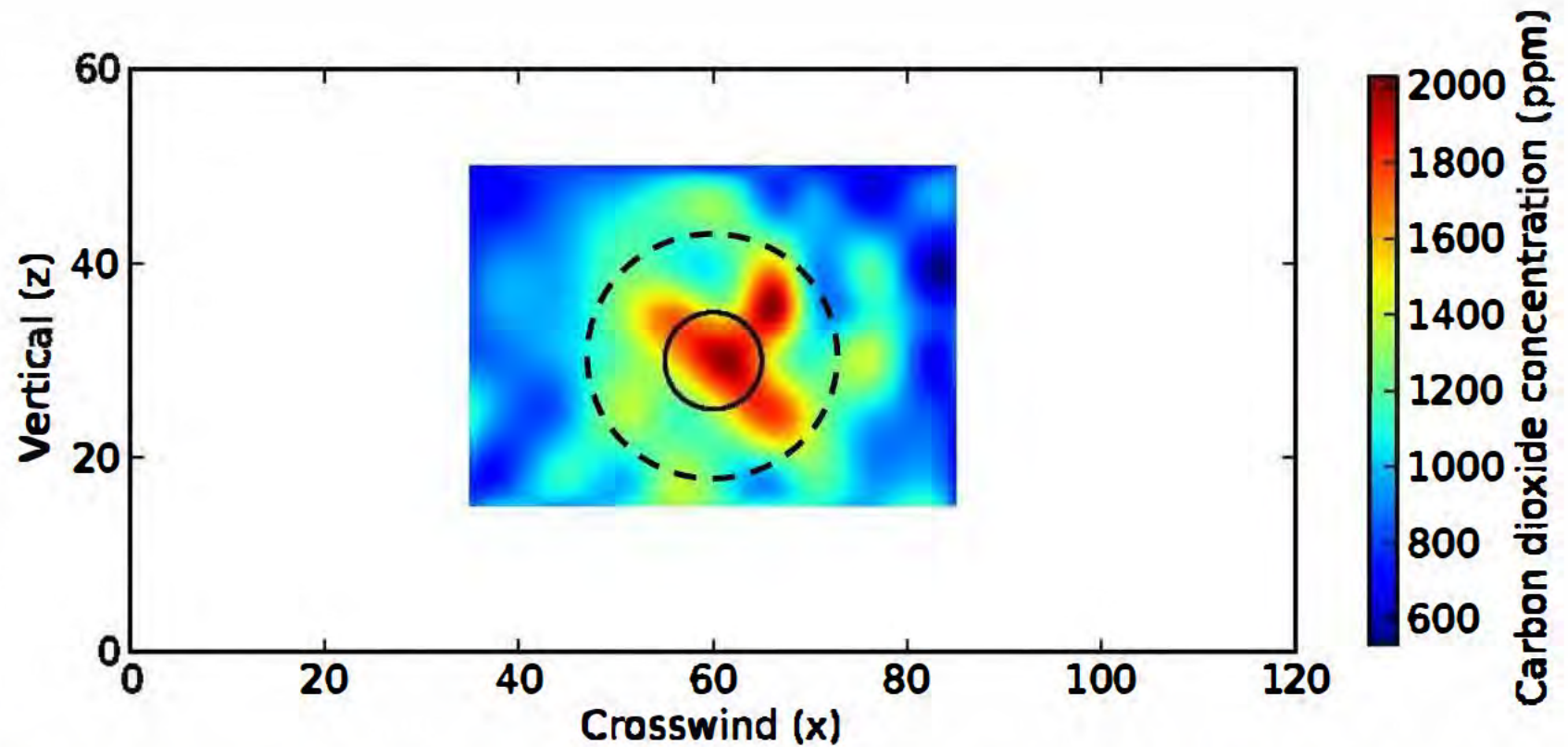


Figure 5.1 Carbon dioxide concentration, ppm, across central cross-section of flight arena. Axes are in cm. Solid black line denotes approximate position of human volunteer's mouth in upwind odour deliver chamber and dashed line indicates outer diameter of high concentration carbon dioxide plume at 50 cm downwind.

### *Clean air*

In clean air assays, clean, climate conditioned air passed through the wind tunnel and flight arena unmodified. To control for any difference in plume flow from the additional carbon dioxide used in host odour experiments, additional clean air drawn from the upwind end of the wind tunnel was pumped into the odour delivery chamber at the same height and volume as the carbon dioxide blend used in host odour assays, but without the addition of any host-associated odours.

#### *5.2.4 Experimental procedure*

Experiments were conducted in the first 3 h of the scotophase, which has been shown to be time of day the NRI *An. gambiae* M form colony is most responsive to human odours (Hawkes et al., 2012). Access to sugar solution was removed from test mosquitoes 3 h prior to experimental assays. Five mated, 5-10-day old females were transferred to a release cage (15 x 15 x 15 cm adult cage with a remotely operated hinged opening) and placed in the centre of the downwind release chamber, ~ 210 cm downwind of the odour source, ~ 5 min prior to the start of each assay. Upon commencement of each assay, the upwind side of the release cage was opened slowly, so as not to elicit the startle response, and closed after 10 min. All mosquitoes were recovered from the wind tunnel at the end of each assay.

Surgical gloves were worn by the wind tunnel operators at all times to limit exposure to additional host odour cues and to prevent contamination of surfaces inside the wind tunnel. Following host odour assays, all fabric netting was removed and washed at high temperature with mild detergent (Surcare, UK) and the inside of the flight arena, odour delivery chamber and release chamber washed with 100% ethanol, followed by a clean water rinse, and allowed to air dry.

## 5.2.5 Data acquisition and analysis

### Activation

A test mosquito was considered activated if it was not found in the release cage at the end of the assay period. Activation was expressed as the number of mosquitoes activated during the assay as a percentage of the number of mosquitoes released in the assay.

### 3D tracking

Three-dimensional position of a single flying mosquito was recorded at 20 ms intervals using Trackit3D (BIOBSERVE GmbH, Germany) tracking system as described in Chapter 3 and 3D coordinate data analysed in a custom-built Python script.

**Table 5.1 Flight track parameters used in analysis of three dimensional flight track data, their definitions and units.**

Term	Description	Units
X	Crosswind displacement	cm
Y	Upwind displacement	cm
Z	Vertical displacement	cm
Track displacement	Total 3D length of track	cm
Straight line distance	Distance from start to end of track	cm
Track duration	Time from start to end of track	s
3D flight speed	Displacement per second	cm s <sup>-1</sup>
3D tortuosity	Straight line distance/track displacement (0 represents completely straight flight)	0-1 index
3D angular velocity	Change in direction per second	° s <sup>-1</sup>
3D track angle	Track angle, relative to due upwind (0°, vector 0,-1,0)	°

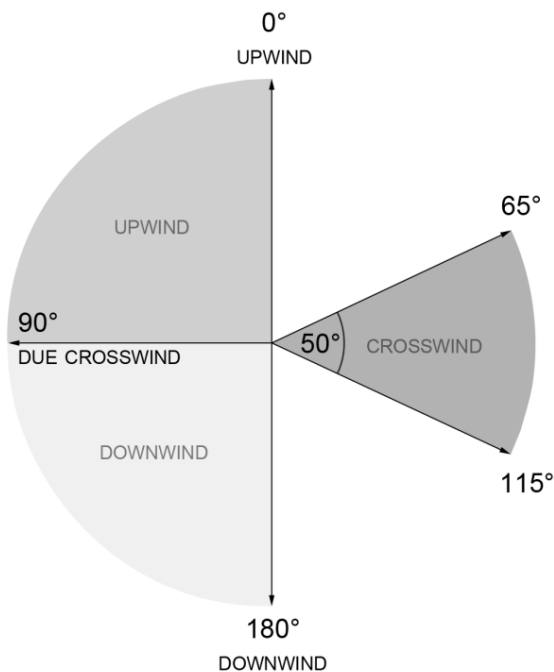
Tracks selected for analysis were at least 0.5 s long (i.e. 25 data points), had no more than ten consecutive missing and/or errant data points and had less than 30% erroneous data points of either type in total. Errant or missing data points in useable tracks were interpolated using a cubic spline algorithm (Jackson, 1979). Interpolation and track parameters for analysis were calculated in a custom built Python programme; track parameters are described in Table 5.1 (calculations used to derive these parameters can be found in Appendix A).

Subjectively, flight tracks fell into one of three categories: smooth, tortuous or dipping (See Appendix B: Supplementary material 5a). These could be distinguished objectively from each other by certain characteristics of the tracks. Standard deviation in mean angle to upwind and tortuosity index both showed a break-point in the distribution of their parameters that separated smoothed and tortuous tracks; this matched the way tracks were categorised by an independent observer asked to visually assess the tracks. Smooth tracks had a standard deviation in their mean angle to upwind of  $\leq 25^\circ$  and a tortuosity index  $\geq 0.7$ , whilst for tortuous tracks these value were  $> 25^\circ$  and  $< 0.7$ , respectively. The majority of tracks consisted of 'dipping' flight, characterised by a repeating 'saw-tooth' oscillating pattern and were identified by qualitative observer assessment. Only dips with at least one complete dip (trough-peak-trough) were used in analysis; tracks which appeared to show incomplete dips were discounted (representing 22.6% of clean air track and 0% of host odour tracks). In addition to the flight parameters detailed above, the mean vertical amplitude (vertical displacement from dip trough to subsequent peak) and mean slopes for ascents and descents were calculated for dipping tracks.

#### *Directional data*

To determine the direction relative to upwind that a mosquito was flying in at any point in time, the 3D angle between consecutive pairs of coordinates was calculated, relative to an upwind unit vector ( $x, y, z = 0, -1, 0$ ; due upwind =  $0^\circ$ ). If  $> 70\%$  of a track's angles were  $\geq 90^\circ$  (i.e. due crosswind and

downwind), the track was considered to be heading downwind. If  $> 70\%$  of a track's angles were  $\leq 90^\circ$  (i.e. due crosswind and upwind), the track was considered to be heading upwind. Crosswind tracks were identified as those where  $> 70\%$  of angles fell between  $65^\circ$  and  $115^\circ$  (i.e.  $25^\circ$  either side of due crosswind). These direction definitions are summarised in Figure 5.2.



**Figure 5.2 Diagrammatic representation of directional heading definitions used to categorise track directions as upwind, downwind or crosswind.**

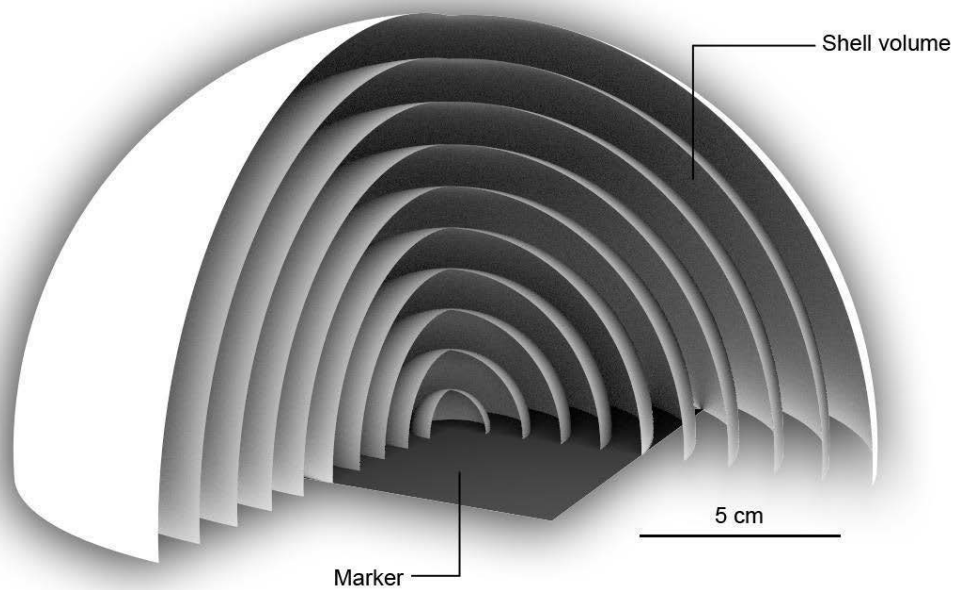
To view the general pattern of up- and downwind flight, the mean angle to upwind of up- and downwind tracks was calculated for smooth tracks in clean air only, owing to an insufficient number of tracks of other types to maintain a minimum N of 5 in host odour.

*Spatial distribution of tracks and relationship to visual cues*

The spatial distribution of tracks within the flight arena was described with a variance to mean ratio (VMR) of track data points in 2D and 3D. The VMR is an index of clustering: VMRs  $> 1$  indicate data are clustered (following a

negative binomial distribution), although they do not identify where clustering occurs, whilst VMRs  $< 1$  indicate data are under-dispersed (binomial distribution). A VMR of 0 is found with constant variables that are not dispersed. Unexpectedly, the spatial distribution of mosquitoes exposed to the host odour treatment were found to be concentrated around one particular infrared transmitting floor marker (10 cm  $\varnothing$ ) intended to be one of eight nonspecific visually contrasting features placed in the visual field to provide contrast for optomotor control of flight direction. Two mosquitoes (from different host odour assays) continued to fly in the vicinity of this one marker; these were the two longest tracks, being 20.86 and 7.86 s, so they were removed from subsequent analysis (see below) to prevent them disproportionately contributing to the data set.

The behaviour around the floor marker was so striking, however, it warranted specific analysis of mosquito response to this stimulus. To assess the pattern of flight near the black marker, the densities of flight track data points in concentric shells, of 1 cm thicknesses, known volume and increasing distances from the centre of the black marker were measured (Figure 5.3). Only shell volumes fully within the field of view of both cameras were included in the analysis, with the outermost shell volume having an outer radius of 20 cm from the floor marker's centre.



**Figure 5.3 Model of concentric hemispherical shell volumes centred around the black floor marker.** Shell radii increase by increments of 1 cm; only the first 10 of 20 shell volumes is shown.

### *Statistical analyses*

Differences in flight parameters between treatments and between track types were compared with one-way analysis of variance (ANOVA). Pearson's chi-squared test with Yates' continuity correction compared differences in activation, height above the floor and data point densities between treatments and track types, whilst linear regression was performed for mean angles over time in average smooth up- and downwind clean air tracks and between dipping ascents and descents. Data were checked for normality graphically (Q-Q plots and residuals versus fitted values) and statistically (Shapiro-Wilk test of normality). All statistical analysis was undertaken in R statistical software (R Development Core Team, 2010).



## 5.3 Results

### 5.3.1 Overview

Flight track details are summarised in Table 5.2. Because the intention was to observe free-flight behaviour, on occasion individual mosquitoes contributed more than one track to the data set. For instance, downwind tracks were necessarily created by mosquitoes which had already flown upwind and may or may not have been recorded doing so since there were corridors along the sides and top of the wind tunnel that were outside the field of view of the cameras. The most conservative estimate would hold that, regardless of how many mosquitoes took off from inside the release chamber, only one mosquito from each assay can be assumed to have created all the tracks from that assay; based on this, the absolute minimum number of replicates is 21 in clean air assays and 18 in host odour assays. For the purposes of data analysis, each track is treated as a replicate; it is likely that most mosquitoes that left the release cage contributed to the total number of tracks, which was 89 and 49 for clean air and host odour assays, respectively.

### 5.3.2 Activation

Host odour significantly increased the proportion of *An. gambiae* released from the holding cage that flew out of the release area (i.e. were 'activated') from 53%, in clean air, to 70% (Chi-squared,  $P < 0.05$ ,  $N = 90$ ).

### 5.3.3 Flight height

Tracks differed significantly in their height above the arena floor according to both treatment and track type; 87.3% of all clean air data points ( $N = 9197$ ) were found at  $\leq 10$  cm above the floor, significantly more than 67.2% of all host odour data points (Chi-squared,  $P < 0.001$ ,  $N = 7372$ ). In both host odour and clean air, a greater percentage of data points from tortuous tracks were found closer to the ground than from smooth tracks (Chi-squared,  $P < 0.01$ ,  $N = 6664$ ; Table 5.3).

**Table 5.2 Summary of data collected in flight characterization assays in clean air and host odour.** Different letters denote significant differences at  $P < 0.05$ .

Odour treatment	No. assay replicates	Total no. insects released	No. responded	Insects			Mean	Mean	Dipping tracks, %	Smooth tracks, %	Tortuous tracks, %
				activated, %	No. tracks	No. data points	track duration $\pm$ SE, s	errant points $\pm$ SE, %			
Clean air	21	105	56	53 <sup>a</sup>	89	9197	2.0 $\pm$ 0.1	9.6 $\pm$ 0.8	46.1 <sup>a</sup>	22.4 <sup>a</sup>	8.9 <sup>a</sup>
Host odour	18	90	63	70 <sup>b</sup>	49	7556	3.0 $\pm$ 0.4	5.4 $\pm$ 0.7	51.0 <sup>a</sup>	14.3 <sup>a</sup>	34.7 <sup>b</sup>

79

**Table 5.3 Flight height data for smooth and tortuous tracks in host odour and clean air.** Different letters denote significant differences in % flight height at  $P < 0.01$ ; shared \* and † denote data not compared.

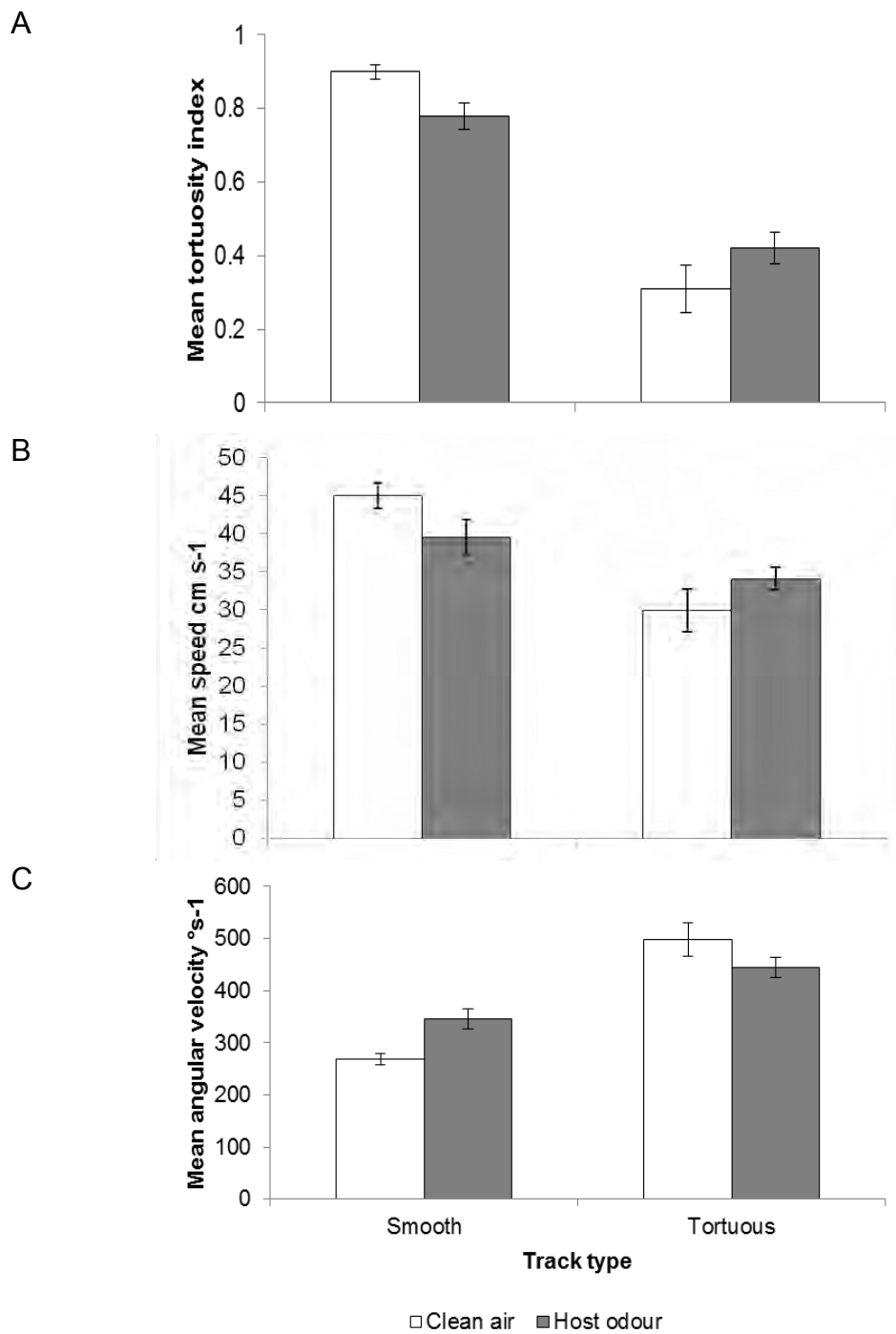
Odour treatment	Track type	No. data points	Mean height	% $\leq$ 10cm height	P < 0.01
Host odour	Smooth	687	13.0	41.3	a*
	Tortuous	3285	13.3	47.1	b†
Clean air	Smooth	1261	11.6	62.4	c†
	Tortuous	1431	7.5	73.0	d*

#### 5.3.4 Track parameters

The mean 3D tortuosity index (Figure 5.4) for smooth tracks in clean air was 0.90, significantly greater (ANOVA,  $F = 7.9$ , d.f. = 1,  $P < 0.01$ ,  $N = 27$ ) and therefore less tortuous than the 0.78 recorded in host odour. Interestingly, there was no difference in mean tortuosity between tortuous tracks in either clean air (0.31) or host odour (0.42) treatments.

Smooth tracks in both treatments had the fastest mean flight speeds (clean air =  $45.0 \text{ cm s}^{-1}$ ; host odour =  $39.6 \text{ cm s}^{-1}$ ; ANOVA,  $F = 2.4$ , d.f. = 1,  $P < 0.01$ ,  $N = 28$ ). However, there was no significant difference between flight speeds of smooth and tortuous tracks in host odour, or between tortuous tracks in either treatment (Figure 5.4).

Although there was no difference between the mean angular velocities (Figure 5.4) of tortuous tracks from clean air ( $497.8^\circ \text{ s}^{-1}$ ) and host odour ( $444.4^\circ \text{ s}^{-1}$ ), both were significantly greater than for smooth tracks from the corresponding treatments (clean air =  $268.4^\circ \text{ s}^{-1}$ , ANOVA,  $F = 37.0$ , d.f. = 1,  $P < 0.001$ ,  $N = 28$ ; host odour =  $346.0^\circ \text{ s}^{-1}$ , ANOVA,  $F = 7.1$ , d.f. = 1,  $P < 0.05$ ,  $N = 24$ ). Host odour produced smooth tracks with a greater mean angular velocity than clean air (ANOVA,  $F = 11.3$ , d.f. = 1,  $P < 0.01$ ,  $N = 15$ ).



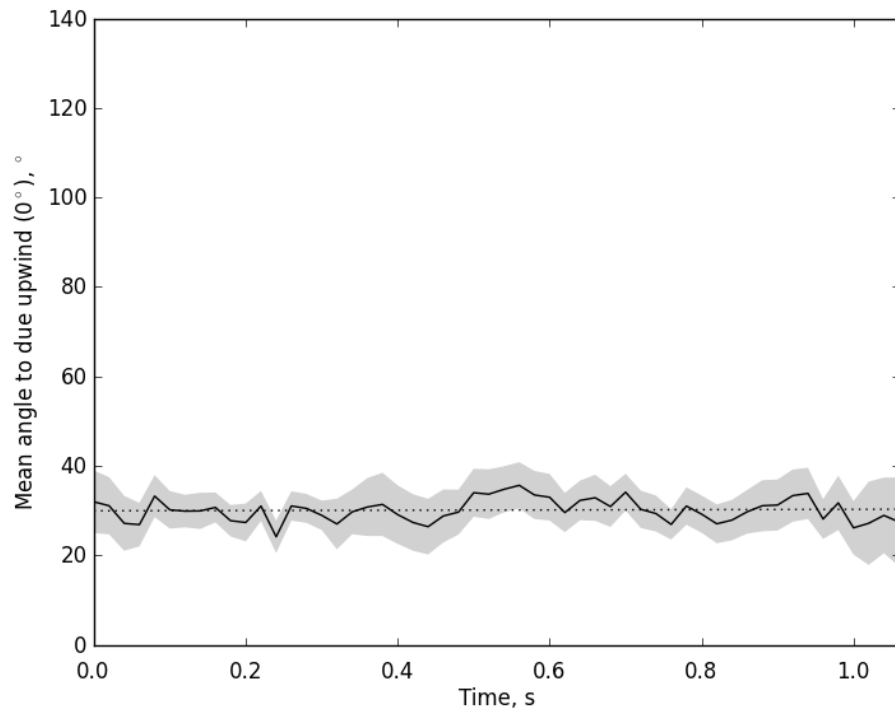
**Figure 5.4 Track parameters for smooth and tortuous tracks in clean air and host odour,  $\pm$ SE: tortuosity (A), speed (B) and angular velocity (C). Clear air smooth N = 20, clean air tortuous N = 8, host odour smooth N = 17, host odour tortuous N = 7. See text for details of statistical analysis.**

### 5.3.5 Directional differences

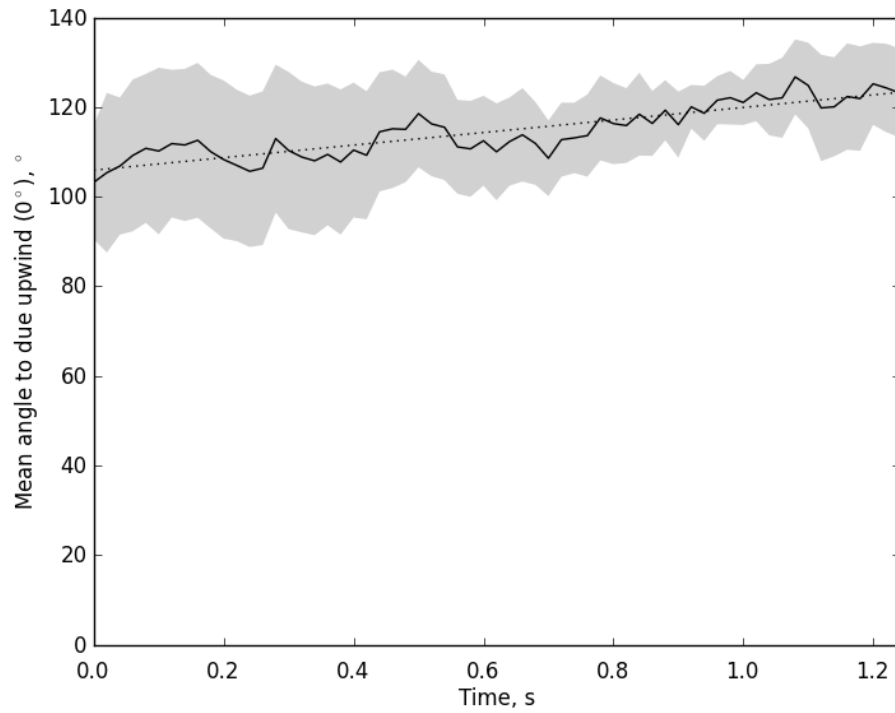
Smooth up and downwind tracks in clean air had remarkably consistent mean angular velocities of  $267.4^{\circ} \text{ s}^{-1}$  ( $N = 5$ ) and  $267.1^{\circ} \text{ s}^{-1}$  ( $N = 11$ ), respectively. These were significantly lower values than recorded for up ( $342.9^{\circ} \text{ s}^{-1}$ ; ANOVA,  $F = 5.4$ , d.f. = 1,  $P < 0.05$ ,  $N = 2$ ) and downwind ( $390.7^{\circ} \text{ s}^{-1}$ ; ANOVA,  $F = 8.3$ , d.f. = 1,  $P < 0.05$ ,  $N = 4$ ) tracks in host odour. Downwind host odour tracks had the largest mean angular velocity (ANOVA,  $P < 0.05$ ).

Upwind tracks had a mean angle to upwind of  $34.3^{\circ}$  in clean air and  $27.8^{\circ}$  in host odour, whilst downwind tracks in clean air had a mean angle to upwind of  $120.2^{\circ}$  and  $119.0^{\circ}$  in host odour; these between treatment differences were not significant. Neither was there a significant change in mean 3D angle to upwind (Figure 5.5) in clean air (linear regression,  $R^2 = 0.001639$ ). However, downwind tracks exhibited a significant increase in their mean 3D angle (Figure 5.5), relative to upwind (linear regression,  $P < 0.001$ ,  $R^2 = 0.7779$ ). These results suggest that mosquitoes flying upwind tend to maintain a steady direction relative to the wind, whilst when flying downwind, they fly in an increasingly downwind alignment.

A



B



**Figure 5.5** Change in mean 3D angle to due upwind ( $0^\circ$ ) of upwind (A) and downwind (B) tracks in clean air,  $\pm$ SE. There is no significant difference in angle to upwind over time in (A) (linear regression); (B) demonstrates a significant increase in angle to upwind over over time (linear regression,  $P < 0.001$ ).

### 5.3.6 *Dipping behaviour*

A distinctive dipping flight behaviour was observed in both treatments, characterised by a pattern of descents towards the floor, followed by a sharp change to ascending flight, followed by a levelling off and subsequent descent again towards the floor (i.e. oscillating through the z axis, but never observed to touch the floor; see Appendix B: Supplementary material 5a). A similar proportion of tracks demonstrated dipping behaviour (Table 5.2) in both clean air (46.1%) and host odour (51.0) assays (Chi-squared,  $P = 0.7$ ,  $N = 138$ ), although there was a significant difference in the proportion of tortuous tracks, with more found in host odour (34.7%) than clean air (8.9%) assays (Chi-squared,  $P < 0.01$ ).

In parallel with previously described track types, more data points from dipping tracks in clean air were found closer to the ground than those from host odour treatments. Specifically, 61% of dipping data points in clean air ( $N = 2427$ ) were found  $\leq 2$  cm from the floor, whilst this figure was only 34% in host odour ( $N = 1784$ ) (Chi-squared,  $P < 0.001$ ). The mean height of dip troughs was also lower in clean air (0.64 cm) than in host odour (1.45 cm) (ANOVA,  $P < 0.001$ ).

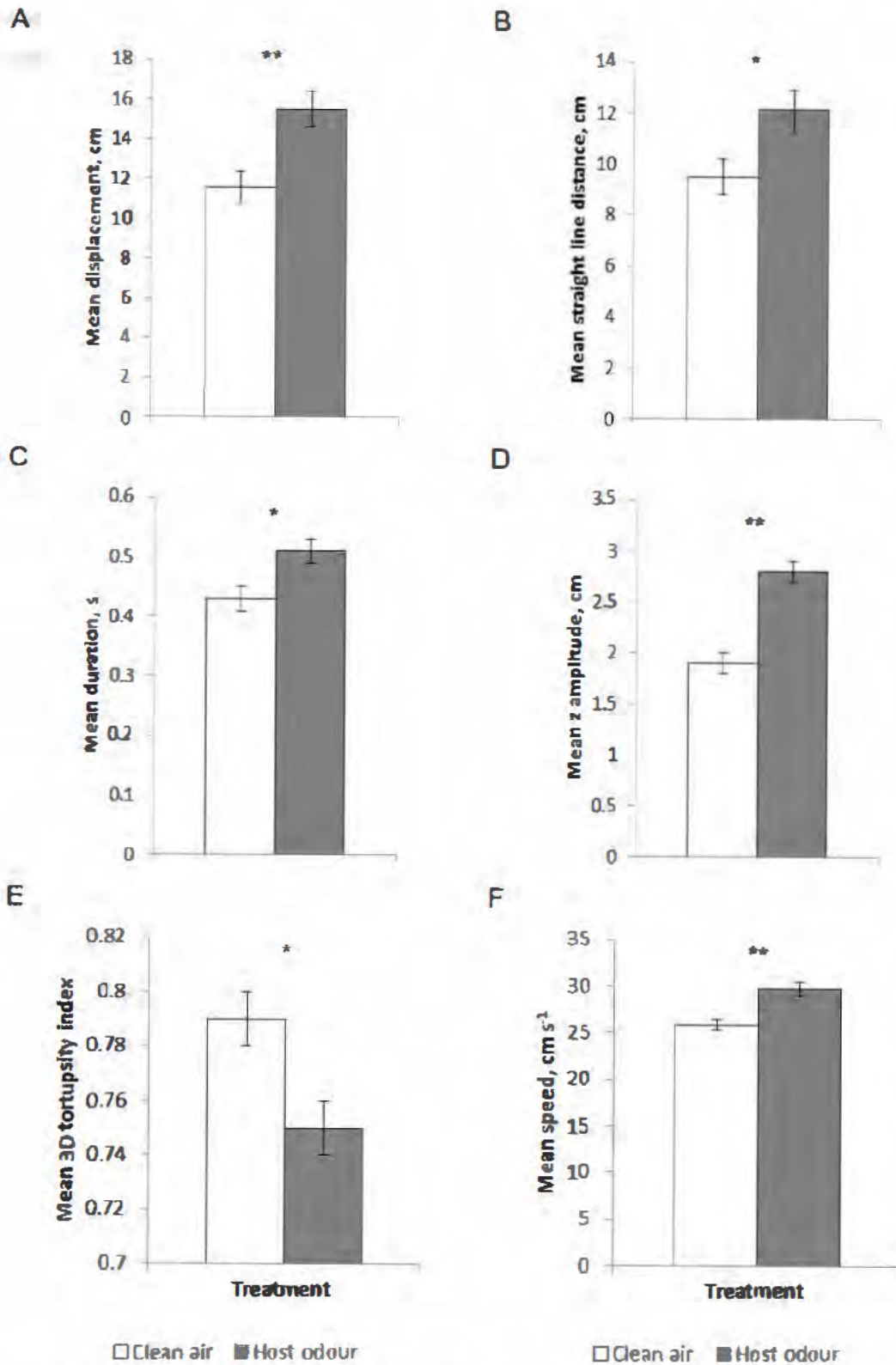
Slope data showed a significant correlation between ascent and descent slopes in clean air dips ( $N = 128$ , linear regression,  $P < 0.05$ ,  $R^2 = 0.03082$ ), whereas a strong correlation was observed in the relationship between ascent and descent slopes in host odour ( $N = 92$ , linear regression,  $P < 0.001$ ,  $R^2 = 0.1266$ ). Mean slopes of both ascents ( $14.1 \text{ cm s}^{-1}$ ) and descents ( $10.0 \text{ cm s}^{-1}$ ) were greater in host odour than ascents ( $11.1 \text{ cm s}^{-1}$ ; ANOVA,  $P < 0.001$ ) and descents ( $8.6 \text{ cm s}^{-1}$ , ANOVA,  $P < 0.01$ ) in clean air (Figure 5.6). This implies that in host odour, dipping flights are larger and somewhat more symmetric than in clean air.



**Figure 5.6 Mean slope values for dip ascents and descents in clean air and host odour,  $\pm$ SE.** Ascent slopes start at the trough of a dip and continue to its vertical peak, whilst descent slopes start at the vertical peak of a dip and continue to the following trough.

Overall, dips in host odour were longer in duration, total displacement and straight line distance travelled, they had greater vertical amplitude and were faster and more tortuous than dips in clean air (Figure 5.7).





**Figure 5.7 Summary of dip characteristics in clean air and host odour,  $\pm$ SE. ANOVA, \* =  $P < 0.05$ , \*\* =  $P < 0.01$ . Flight parameters are displacement (A), straight line distance (B), tortuosity, (C), vertical amplitude (D), 3D tortuosity (E) and speed (F).**

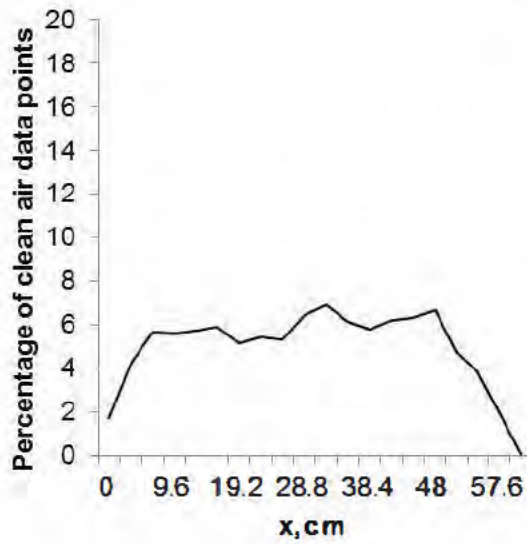
### 5.3.7 Responses to the black floor marker

Variance to mean (VMR) ratios provide an index of clustering: VMRs  $> 1$  indicate data follow a negative binomial distribution and are clustered, although they do not identify where clustering occurs. The low number of data points at the edge of the field of view in both data sets have produced VMRs  $> 1$ ; however, the higher VMRs in host odour suggested there is additional clustering in this data set.

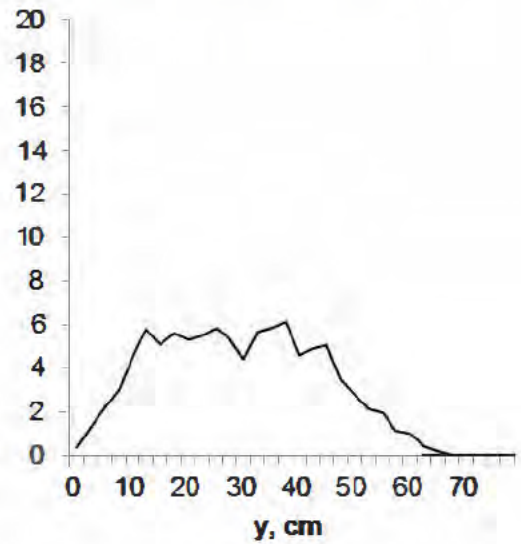
For 2D data (x-y projection), the variance to mean ratio (VMR) for clean air was 2.2, much lower than the VMR of 9.2 for 2D host odour data, i.e., the positions of mosquitoes were more evenly distributed in the x-y plane in clean air, although they were still 'clustered'. The VMRs for 3D data were also computed, but, based on the previously reported finding that mosquitoes flew close to the ground, only for the lowest 15 cm of the vertical (z-axis) profile (at 5 cm vertical intervals), encompassing 81% of clean air and 68% of host odour data. These results for 3D data were found to be similar to 2D data; the VMR of 3.9 for clean air was lower than that for host odour, which was 5.8.

Figure 5.8 and Figure 5.9 show the x-y distribution of data points from clean air and host odour data sets, respectively. Track data points are evenly distributed across both x and y axes in clean air, tailing off towards the edges of the cameras' shared field of view, as expected. Host odour data, however, show peaks in both x and y axes, at locations which correspond to the central position of a floor marker intended to provide visual feedback for optomotor navigation.

Crosswind (x) distribution



Up/downwind (y) distribution



x-y distribution

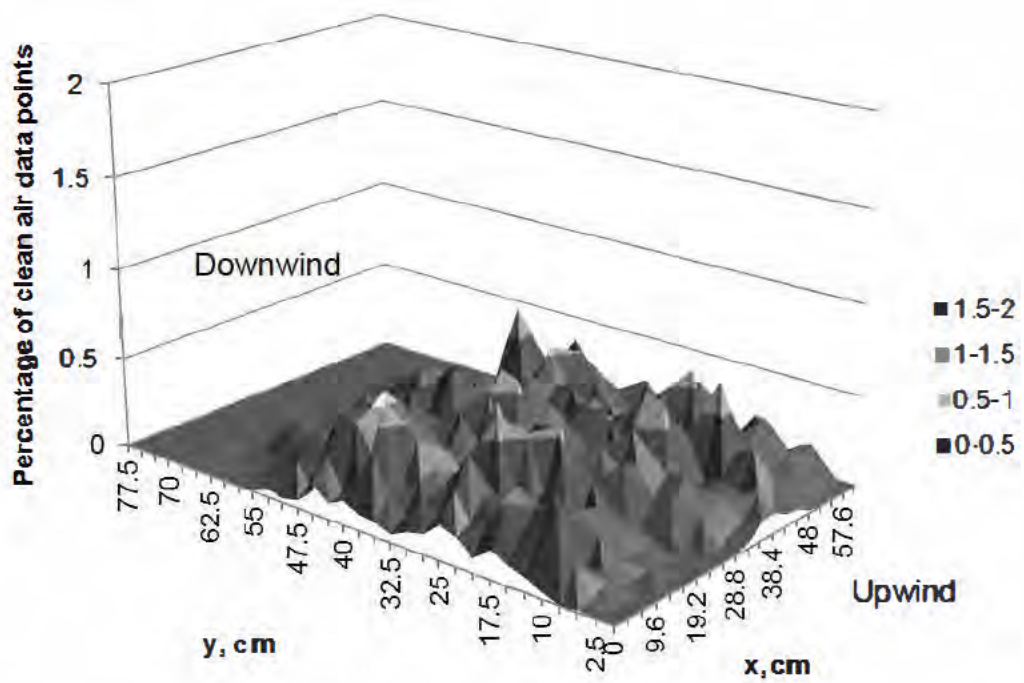
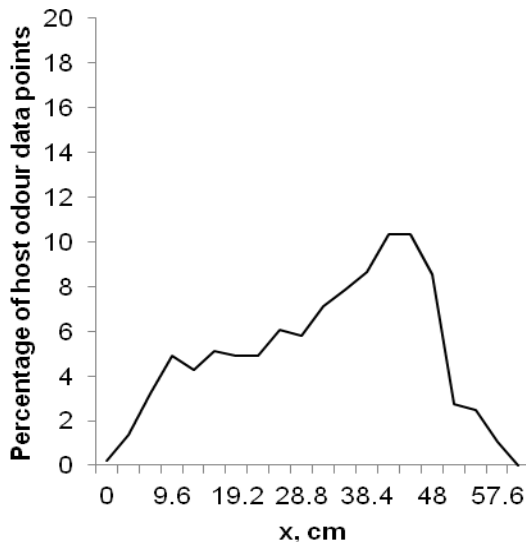
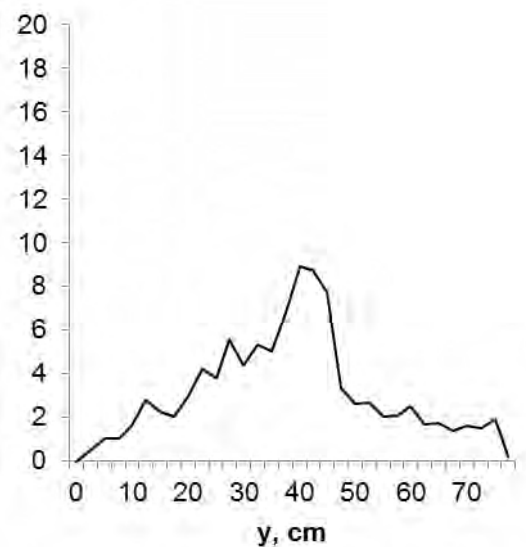


Figure 5.8 Spatial distribution of clean air data points in x (crosswind), y (up/downwind) and across the x-y plane. X and y charts show how data points are spread throughout a cross-section of the flight arena; the x-y surface chart shows data point distribution across the x-y plane.

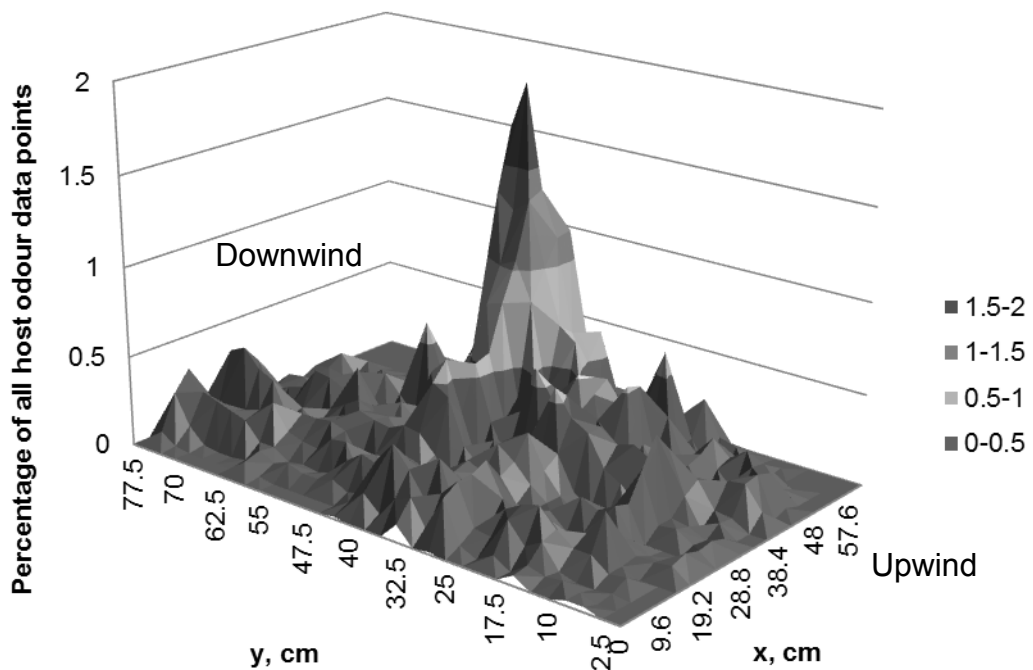
Crosswind (x) distribution



Up/downwind (y) distribution

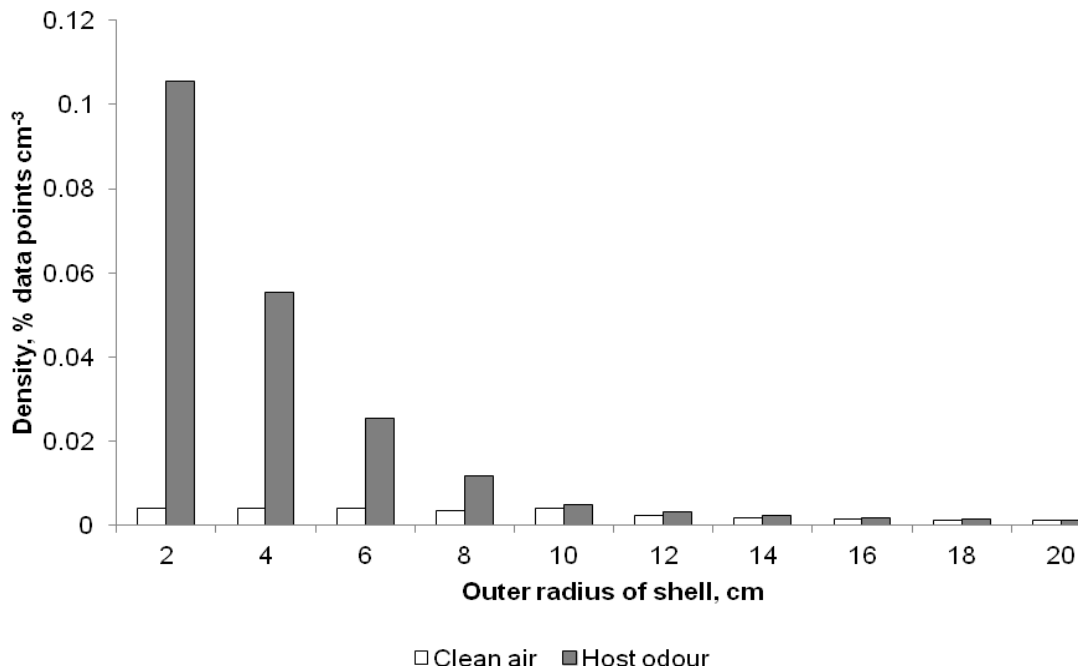


x-y distribution



**Figure 5.9** Spatial distribution of host odour data points in x (crosswind), y (up/downwind) and across the x-y plane. X and y charts show how data points are spread throughout a cross-section of the flight arena; the x-y surface chart shows data point distribution across the x-y plane.

The density of the percentage of each treatment's data points within hemispheric shell volumes emanating from the floor marker's central position clearly demonstrate marked differences between treatments (Figure 5.10). The data points of clean air tracks show little variation in their density across shells. There is, however, a marked difference in the density of data points for host odour tracks across shells, with density increasing towards central shells. Furthermore, differences between densities of clean air and host odour data points were significant (Chi-squared,  $P < 0.01$ ); at the central shell the density of host odour data points was  $> 25$  times that of clean air data point density, suggesting movement over the marker was random in clean air, whereas it was concentrated over the marker in host odour.



**Figure 5.10 Comparison of distribution of data point distances from centre of floor marker in clean air and host odour treatments.** Density given as percentage of data points for each treatment that occurred within shells of known volume and distance from the centre of the marker. Differences between clean air and host odour are significant (Chi-squared,  $P < 0.01$ ).

## 5.4 Discussion

Previous attempts to track the flight of *An. gambiae* have been hampered by the need to operate cameras in the low light levels normally experienced by this crepuscular species and the constraints of choosing to work with small odour plumes. For instance, of 245 female *An. gambiae* assayed in a wind tunnel, Beeuwkes et al. (2008) deemed only 14 individuals to have made sufficient odour plume contact to demonstrate any effects of interaction with the stimuli. Of the 119 activated females that flew in the experiment reported here, it was possible to analyse 138 3D tracks (49 from host odour and 89 from clean air assays).

Both clean air and host odour treatments resulted in tracks described as smooth, tortuous or dipping, each of which could be characterised by quantifiable differences in parameters obtained from 3D tracking. Dipping flight accounted for about half of all tracks in both olfactory environments, but there were more tortuous flights in host odour assays. That each type of flight occurs in the presence and absence of host-associated odours (Table 5.2) is of interest, indicating that mosquito flight is not reducible to a single 'type' based on specific stimuli, but is rather composed of a suite of different flight strategies for exploring and exploiting an environment, appearing across olfactory situations, but differing in the expression of particular common features. 'Modular stacking' of orientation mechanisms in this way equips organisms with the resilience to survive physical damage, environmental complexity and fluctuations in the signals they process (Gomez-Marin et al., 2010).

### *Activation*

There are mixed reports on the activation behaviour of *An. gambiae* within clean air streams and odour plumes. It is particularly difficult to differentiate between factors that elicit upwind flight and those that result in upwind *host-seeking* flight (Clements, 1999). Attention should also be paid to the time at which assays are conducted, as *An. gambiae* show an increase in

spontaneous activation following stimulation with host odours, but mainly in the early part of the subjective night (Hawkes et al., 2012). Around half of test mosquitoes were observed making upwind flight in clean air, increasing to 70% when whole human odour plus carbon dioxide was tested. Takken et al. (1997) found 85% of host-seeking *An. gambiae* s.s. flew upwind in clean air, increasing to a maximum of 90% with the addition of 6 s pulses of 5% carbon dioxide at 230 ml min<sup>-1</sup> coupled with a high concentration of acetone (120 µg L<sup>-1</sup>). However, Spitzen et al. (2008) and Beeuwkes et al. (2008) reported no change from 78% and 64%, respectively, in the activation of upwind flight in *An. gambiae* s.s., regardless of whether human skin odour was present. In other experiments, only 12.5% activation has been reported in *An. gambiae* (Healy & Copland, 1995). Some of the discrepancies between these reports may be due to differences in the experimental setups, such as the size of arena and presentation of odour sources. Findings reported here support the view that there is a propensity for *An. gambiae* to make upwind flights in a moving stream of clean air and substantiate the role of host-associated kairomones as long-range wind-borne activators.

### *Ranging flight*

Once activated, the majority of clean air tracks (46.1%) were characterised by a distinctive dipping pattern, which also represented the majority of tracks in host odour (51.0%; Table 2). Individuals stayed close to the floor (81% of clean air and 68% of host odour data points were within 15 cm of the floor, even though the centre of the host odour & CO<sub>2</sub> plume were 35 cm above the floor of the arena), ascending and descending as they moved around the arena. By remaining close to the ground, this kind of ranging flight may avoid the faster wind speeds or gusts of wind which increase with elevation under natural conditions; viscous drag reduces wind speed to 0 cm s<sup>-1</sup> at the solid-gaseous interface, thus flight requires decreasing energy to maintain the same speed with increasing proximity to the ground (Gillett, 1979; Denny, 1993). The majority of *An. gambiae* ranging behaviour may be composed of such flights. See later text for a discussion of the function of vertical displacement in dipping behaviour.

### *Plume following*

Despite differences in the plume structure of the respective studies, *Ae. aegypti* behave in a way more akin to pheromone-tracking male moths, 'casting' cross-wind upon leaving a plume and surging upwind when inside a plume (Dekker & Cardé, 2011). Variations in their sensitivity to light (Land et al., 1999) and the natural light conditions experienced by day-flying species could account for observed differences between this species and *An. gambiae*'s; slower, less direct flight may be better suited to dimly light environments. Unlike mate-seeking moths, which must locate a near-point source of highly specific and constant pheromones, anthropophilic mosquitoes must locate a rather larger and more variable odour plume from a potentially mobile source, the odour composition of which has not been selected to attract haematophagous organisms (Cardé & Gibson, 2010). Systematic horizontal 'casting' typical of moth flight (Baker, 1990; Cardé, 1996) may be inefficient in this context.

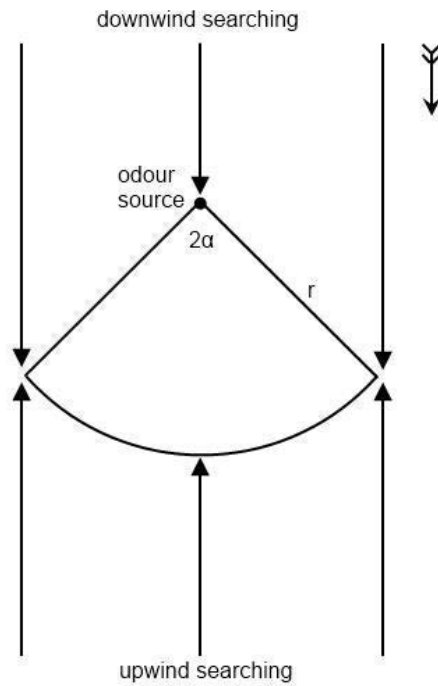
### *Plume finding*

The greater speed of smooth tracks in clean air recorded in the present study is also seen in *Cx. quinquefasciatus* (Lacey & Cardé, 2011) and has been previously reported for *An. gambiae* s.s. (Beeuwkes et al. 2008). These quick, directionally focused flight patterns may reflect a means of moving quickly and directly through space, resulting in sampling of a large spatial footprint and thereby possibly increasing the likelihood of encountering potential host-odour plumes.

Geometrical modelling of odour plume tracking scenarios by Sabelis and Schippers (1984) suggests that whilst cross-wind searching (as in moth casting) is an efficient means of acquiring plume information in unidirectional winds with very little variation in mean direction, this may not be the case in less consistent natural environments. In fact, when mean wind variation is  $> 30^\circ$ , up and downwind searching strategies are optimal; given that downwind flight is both a low energy means of movement and likely to result



in plume entry at a point closer to the odour source than upwind flight (Figure 5.11), downwind orientation strategies may provide a valuable alternative means of seeking initial odour plume contact.



**Figure 5.11 Simplified dispersal of odour from a point source, where  $r$  is the maximum distance of odour detection.** Feathered arrow indicates mean wind direction and  $2\alpha$  the range of wind directions. Upwind searching will always result in an encounter with odour at distance  $r$  from the source; downwind approaches, however, will enter the odour at a distance  $\leq r$  from the source, and  $r/2$  on average, and thus start odour tracking closer to the odour source (After Sabelis & Schippers, 1984).

It should be reiterated that the area in which 3D flights were tracked in the present study broadly equates to the area over which a whole host odour plume was present; as such it was not possible to directly observe changes on entering or exiting plumes, only to infer differences between clean air and host odour responses. Furthermore, experimental wind tunnels can be biased in their representation of directional data because the downwind release of insects prejudices against crosswind and downwind flight. In addition, the flight arena used in the present study is smaller across its

crosswind axis, biasing results in favour of up and downwind flight, as does the shape of the three dimensional recording area, which is determined by the rectangular field of view of each camera. These biases may account for the greater number of up and downwind tracks, compared to crosswind tracks, observed in this experiment.

### *Visual responses*

Female mosquitoes in host odour were observed to spend a disproportionate amount of time in flight around a visually conspicuous floor marker, which was intended only to provide visual feedback necessary for optomotor-guided anemotaxis. Results demonstrate that olfactory cues from a potential host can mediate a responsiveness to visual cues which is not evident in clean air alone. This is perhaps unsurprising, given the astonishing visual sensitivity of crepuscular and nocturnal mosquitoes, which has been achieved at the expense of resolution (Land et al., 1999).

*Anopheles melas*, known to feed on large bovids, has previously been shown to avoid visually conspicuous flight traps in clean air, represented by low catch rates, yet the addition of a calf as bait resulted in increased catches in the same trap. The more opportunistic feeder *Cx. thalassius* was caught in high numbers, regardless of odour bait (Snow, 1976). In this case, differential responses to visual stimuli appear to reflect strategies leading to suitable hosts; the more discerning *An. melas* avoids objects with inappropriate (including absent) odour profiles, only being attracted to visual cues that may indicate a suitable host when coupled with its associated kairomones. *Aedes* and *Mansonia* spp. also show a preference for black, red and blue targets over white and yellow, both during the day and at night, with increasing catch inversely proportional to the luminous reflectance of light from each trap colour (Browne & Bennett, 1981). As flight concentrated around the floor marker only occurred in the presence of host odour, it is improbable that females were virgins using the floor marker as an impromptu swarm marker (Charlwood et al., 2002).

## *Vertical displacement and orientation*

### *Plume following*

The remarkably consistent pattern of dipping flight characterised in this study poses questions about how crepuscular and nocturnal mosquito species navigate in their environment. Dekker and Cardé (2011) report a regular, odour-triggered zigzagging in *Ae. aegypti*, control of which is attributed to a motor programme. In odour, this programme may offer mosquitoes the adaptive advantage of contacting or re-contacting odour plumes by increasing vertical and crosswind movements. Kennedy (1983) describes counter-turning in moths as a programmed pattern, generated by the insect central nervous system and initiated by a single input change, which is not directly modulated by on-going inputs to the chemosensory system. It seems plausible that a similar programmed response may be controlling dipping behaviour, with internally-controlled rates and directions of turning, controlling only flight height to avoid colliding with the ground. Expressing similar patterns of movement in response to different physiological needs and sensory requirements is also an efficient way of controlling behaviour, as similar patterns can be employed across the life cycle (Gomez-Marin et al., 2010).

### *Plume finding*

Use of a similar motor programme in clean air must extend some adaptive advantage to *An. gambiae* s.s., particularly given the energy demands of this type of flight. In clean air dipping behaviour, individuals tended to make more staggered ascents and descents, seen in the weaker correlation between slopes. Optomotor-guided anemotaxis has been the preferred explanation of orientation in flying insects, whereby flight speed and direction is controlled by feedback from visual flow fields moving over the field of view (Kennedy, 1940; David, 1986). Given the capabilities of the visual system in *An. gambiae* s.s., it is unlikely that the small angular profiles of the visual cues provided across the flight arena floor would be resolvable by individuals flying very close to the floor, such as in dipping flights. If similar vertical

displacement motor programmes exist across Culicid taxa, it is possible that rapid growth and shrinkage in the appearance of ground patterns across the ventral ommatidia could strengthen optomotor orientation feedback cues, as the transverse flow of these same cues is reduced when displacement is largely vertical. Indeed, mosquitoes may not always require constant sampling of the optic flow field, as speculated by Dekker and Cardé (2011), and intermittent sampling of visual features at dip peaks may provide sufficient optic feedback for orientation. In this scenario, dipping females may only fly sufficiently high enough to bring adequate elements of the visual environment into sight to facilitate orientation, avoiding flying higher than necessary and thereby escaping the higher wind speeds found at greater elevation.

Alternatively, mosquitoes, and nocturnal species in particular, may employ more than one orientation strategy. In conditions where light levels are so low they may prohibit successful visual orientation (for example, inside unlit houses or during overcast, moonless nights), or where landscape features are infrequent or poorly contrasted, dipping may provide other changes in sensory input that are adequate to orient by. Although evidence is not available from the present study, the repeating pattern of dips observed could indicate that Gillett's (1979) theory of movement through the boundary layer (suggested for day-flying mosquitoes) may be a viable alternative nocturnal orientation strategy. Premised on the ability of mosquitoes to detect changes in their ground speed as they move through the wind velocity profile found across the boundary layer, no evidence has yet been found for this method of orientation. Sensory physiologists are, however, elaborating the role of the Johnston's organ in *Drosophila* in detecting, and differentiating between, sound and air currents, and in initiating odour-tracking and improving visual-motion processing (Budick et al., 2007; Yorozu et al., 2009; Duistermars & Frye, 2010). It is feasible the combined expression of these interrelated sensory systems could result in such a controlled form of surface navigation.

Cooperband and Cardé (2006) observed *Cx. quinquefasciatus* approach four different counter-flow traps from below the trap entrance, whilst Dekker et al. (1998) found *An. gambiae* s.s., *An. arabiensis* and *An. quadriannulatus* all show a preference for biting legs and feet, but *An. gambiae* s.s. and *An. arabiensis* will switch to biting other body parts if these parts are close to the ground. Perhaps mosquitoes flying at low elevations are more likely to encounter hosts at rest on the floor or lying on beds, or biting at this elevation may help the organism to avoid defensive host behaviour. Further experimental manipulation is needed to test these hypotheses.

### *Odour contact*

Overall, tracks of all types were found higher above the floor in host odour rather than clean air. Furthermore, vertical amplitude and ascending and descending slopes of dipping tracks in host odour were greater than those in clean air. This suggests the presence of host-associated olfactory cues in the air stream may encourage flight at higher elevation and with greater vertical displacement in stereotyped dipping.

Tentative, staggered flights in clean air contrast with the exaggeration of dip slope features seen in host odour, which result in an overall increase in vertical oscillation. In host odour treatments, this led individuals to sample a larger cross section of the host odour plume; the costs of greater dip amplitude may be outweighed by the advantage of sampling more of an odour plume's vertical profile. De Jong and Knols (1995) provide some evidence that *An. gambiae* approach human hosts around the head, then descend towards the lower leg and foot region. Carbon dioxide is released through a host's air passages at the nose and mouth and thus typically is released well above ground level in standing or sitting hosts. As horizontal odour gradients may be blurred or merged between humans in groups or shared domiciles, an exaggerated dipping strategy might bring females sensing skin odour compounds closer to the carbon dioxide plume emanating from a potential host's airways, providing a more reliable indication of location than a large, ragged odour plume, and a certain

indicator of a living host, as opposed to odours deposited on bedding or clothes. Furthermore, as sensory neurones of multiporous peg sensilla on maxillary palps respond to small changes in carbon dioxide concentration (Kellog, 1970), vertical oscillations would repeatedly take antenna in and out of elevated carbon dioxide plumes, facilitating a sampling pattern which would reduce the likelihood of habituation, even when encountering pulsed, intermittent odour packets (Murlis & Jones, 1981).

### *Conclusions*

Physically and sensorially complex real-world environments demand a range of flexible appetitive flights from host-seeking mosquitoes. These may include, but are not necessarily limited to, the following flight types observed in the current experiment: low-flying dipping behaviour, possibly utilising lower wind speeds in the boundary layer; faster, more direct upwind flights, which might move individuals onto new habitat patches; and downwind sweeps, where individuals move in increasingly downwind-aligned paths, perhaps borne by the wind itself. Wind tunnel experiments with alternative setups may yield more decisive findings about directional ranging.

The astonishing accuracy with which dipping mosquitoes control their distance from the arena floor hints at the possibility of an alternative modified version of the optomotor feedback system of navigation in *An. gambiae* and possibly the existence of an unreported mechanism that allows individuals to gauge their distance from surrounding surfaces. Of great relevance to understanding medium and close range orientation in *An. gambiae* and, by extension, how to design behaviourally targeted trapping devices, is the observation that mosquitoes appear to be deviated from their host-seeking activities by visual cues, but only in the presence of host odour. This suggests that once an odour threshold has been triggered, suitable elements of the visual landscape are perceived as potential hosts, or routes towards potential hosts. The exact nature of mosquito responses to these cues remains unknown, but warrants further study; a more detailed investigation of this behaviour is presented in Chapter 6.

## 6 HOST-SEEKING BEHAVIOUR OF *ANOPHELES GAMBIAE* IN RESPONSE TO VISUAL AND OLFACATORY STIMULI

### 6.1 Background

Visual perception is important in all aspects of the mosquito life cycle, for correcting drift in anemotactic orientation (Kennedy, 1940) and locating resting (Hecht & Hernandez-Corzo, 1963) and swarming sites (Gibson, 1985; Charlwood et al., 2002) in both males and females, with the visual ecology of females particularly important in host-seeking (Kawada et al., 2006) and oviposition (Huang et al., 2007). The impressive nocturnal visual performance of mosquitoes and other nocturnal insect taxa is likely facilitated by a number of factors, including behavioural adaptations, such as slower locomotion, optical structures that produce high contrast and visual gain (a high amplitude electrical response per unit contrast and slower responding photoreceptors, respectively), and the possibility of higher visual processing mechanisms, such as temporal and spatial summation, although these mechanisms are poorly understood (Warrant & Dacke, 2011). These adaptations increase the reliability of the visual environment, but reduce its resolution to coarse, slow moving features.

Mosquitoes are unusual amongst the Diptera in having nocturnal apposition eyes. This design is suboptimal for visual resolution in low light levels, as superposition eyes can offer peripheral optical sensitivity which is greater by up to three orders of magnitude (Warrant & Dacke, 2011). Despite this, nocturnal and crepuscular mosquito species, including *An. gambiae*, have visual systems adapted to the photic niches they occupy. The unusual conical-shaped fused rhabdoms of *An. gambiae* more than double the angle over which their ommatidial structure can trap light compared to more commonly found cylindrical open rhabdoms. This increases the gain of light-gathering power by up to nine times (Land et al., 1997).

Mosquito ommatidia have larger facets on the antero-ventral area of the eye, as opposed to the antero-dorsal area, as is usually seen in many other flies, especially in the higher order Diptera. The enlarged hearing organs (antennae and basal pedicel) and mouth parts of mosquitoes are situated in the antero-dorsal area, where the acute zone of vision in higher Dipteran flies is most commonly found. Presumably, this placement of mosquito ommatidia enhances visual perception of dimly lit ground patterns during optomotor-guided navigation at night (Land, 1997). Furthermore, a larger area of the head is covered in ommatidia in females than in males (Figure 6.1) in all mosquito genera studied, with the exception of diurnal *Toxorhynchites*, which do not take blood meals from vertebrate hosts (Land et al., 1999). Eye anatomy in flying male insects generally relates to chasing mates on the wing, so presumably the evolutionary pressure for a larger area of visual sampling in female mosquitoes may relate to dimorphic behaviour, such as host-seeking and oviposition.



**Figure 6.1 Photographs of the ventral view of the head of male and female *An. gambiae*.** The female (A) has a greater number of rows of ommatidia extending across the base of the head, whereas in the male (B) the number of rows of ommatidia shrinks towards the point where the two eyes meet at the base of the head. Photographs courtesy of Gareth Jones, University of Brighton.



To understand the role vision plays in the behavioural sequence that leads host-seeking female mosquitoes to potential blood meals, visually driven behavioural responses have often been interpreted from landing and trap catches. Suction traps with black panels or risers have been shown to catch more mosquitoes than those with transparent or weathered plywood panels and risers (Bidlingmayer & Hem, 1979). The high proportion of mated, non-gravid females in these catches suggests the observed attraction relates to host-seeking behaviour. Presumably, opaque black panels and risers are easier to avoid than transparent ones, implying the larger catches in these traps result from a positive attraction to their visual features. These features seem to be attractive up to ~ 20 m away for the majority of Floridian mosquito species caught, with *Cx. quinquefasciatus* apparently only responding to visual stimuli from around 7.5 m distance (Bidlingmayer & Hem, 1980). Moreover, there is competition between adjacent visual features, with a solitary visual trap predicted to yield a catch around five times that of a trap flanked by four competing visual targets. Visual attraction has also been shown in field catches of *Anopheles* and *Mansonia* species in West Africa, even on moonless nights (Gillies & Wilkes, 1982); whilst mean light intensity differs by around 11 orders of magnitude between day and night conditions, visual contrast remains the same regardless of light level (Warrant & Dacke, 2011). The addition of carbon dioxide or other olfactory cues may significantly alter the attractiveness of visual cues (Snow, 1976).

These field studies hint at the potentially important role visual features play in host-seeking behaviour. This is perhaps unsurprising, given the astonishing visual sensitivity of crepuscular and nocturnal mosquitoes. Whilst laboratory-based video and tracking technology has been used to great effect in elucidating mosquito responses to olfactory stimuli and plume structure, visual responses, and the interaction between vision and olfaction, have, as yet, not been investigated. Some of these sensory modalities are well understood in *Drosophila melanogaster* Schwarzbäuchige Taufliege (Diptera: Drosophilidae), but research on this species focuses on identifying the fundamental behavioural algorithms used in navigation (Duistermars & Frye,

2010), flight control (Budick et al., 2007) and optomotor anemotaxis (Frye et al., 2003). A parallel research endeavour that seeks to precisely quantify the visually-driven responses of host-seeking mosquitoes has the potential to contribute to our understanding of both insect sensory physiology and the key interface between malarial mosquito and human host. The aim of this experiment is to characterise the types of flight observed in free-flying female *An. gambiae* in relation to visually conspicuous and inconspicuous objects and to test the hypothesis that their flight response to these objects is modulated by the presence of host odour.

## **6.2 Materials and methods**

### *6.2.1 Mosquitoes*

Female *Anopheles gambiae* s.s. (M molecular form) used in experiments were reared as described in Chapter 3.

### *6.2.2 Wind tunnel and flight arena*

Experiments were carried out in a wind tunnel and flight arena described in Chapter 3, using the same environmental parameters as listed.

### *6.2.3 Odours*

Two odour environments were tested: a treatment of whole host odour with additional carbon dioxide and a control of clean air. Both odour treatments are described in Chapter 5.

#### *6.2.4 Visual and physical stimuli*

To test the effect of host odour on the flight response to visually conspicuous objects, a solid plastic square target (20 x 20 cm; thickness 0.3 cm; Alana Ecology, UK) that appears black to mosquito and human eyes, but is clear when observed through a video camera because it transmits infra-red light > 830 nm, was used as a visually conspicuous treatment. This black target was placed upright on a transparent Perspex stand ~ 15 cm above the arena floor, perpendicular to the wind direction, in the centre of the cameras' shared fields of view and aligned with the plume of highest carbon dioxide concentration emanating from the host (see Figure 5.1, Chapter 5). The responses to this black visual treatment target were recorded under two test conditions: 1) in the presence and 2) in the absence of host odour. To control for the potential physical disturbances caused by the target to the laminar flow of air, the effect of a solid plastic target of the same dimensions, but 'clear' in the visible and infra-red wavelengths, was also recorded with and without host odour present. Diffuse lighting from beneath the flight arena only ensured there was no glare or reflectance from either target.

#### *6.2.5 Experimental procedure*

The experimental protocol described in Chapter 5 was used in the current series of experiments. Both targets and their stands were washed with 100% ethanol between experimental assays.

#### *6.2.6 Data acquisition and analysis*

##### *Activation*

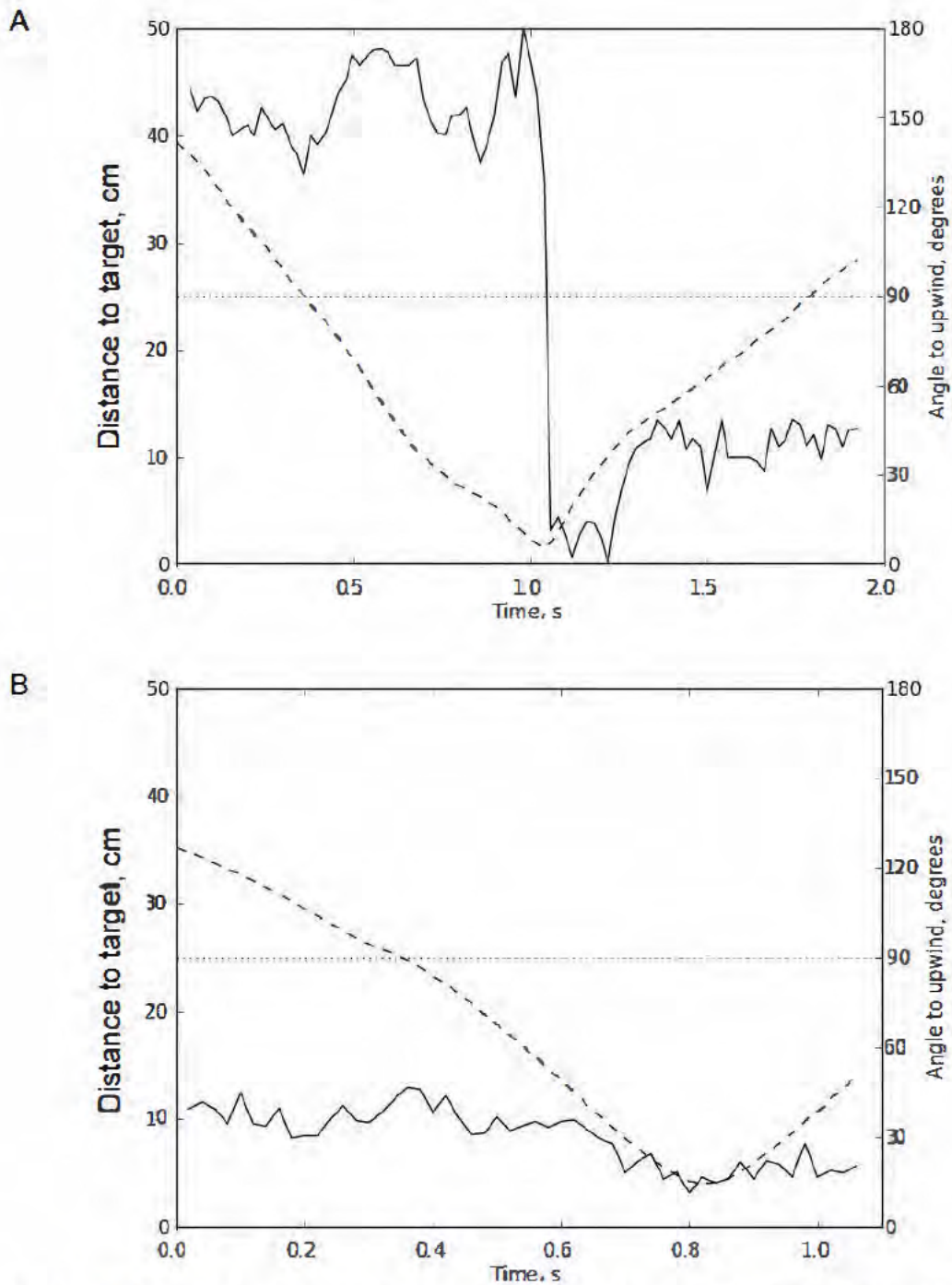
A test mosquito was considered activated if it was not found in the release cage at the end of the assay period. Activation in each of the four assays described above was expressed as the number of mosquitoes activated during the assay as a percentage of the number of mosquitoes released in the assay.

### *3D tracking*

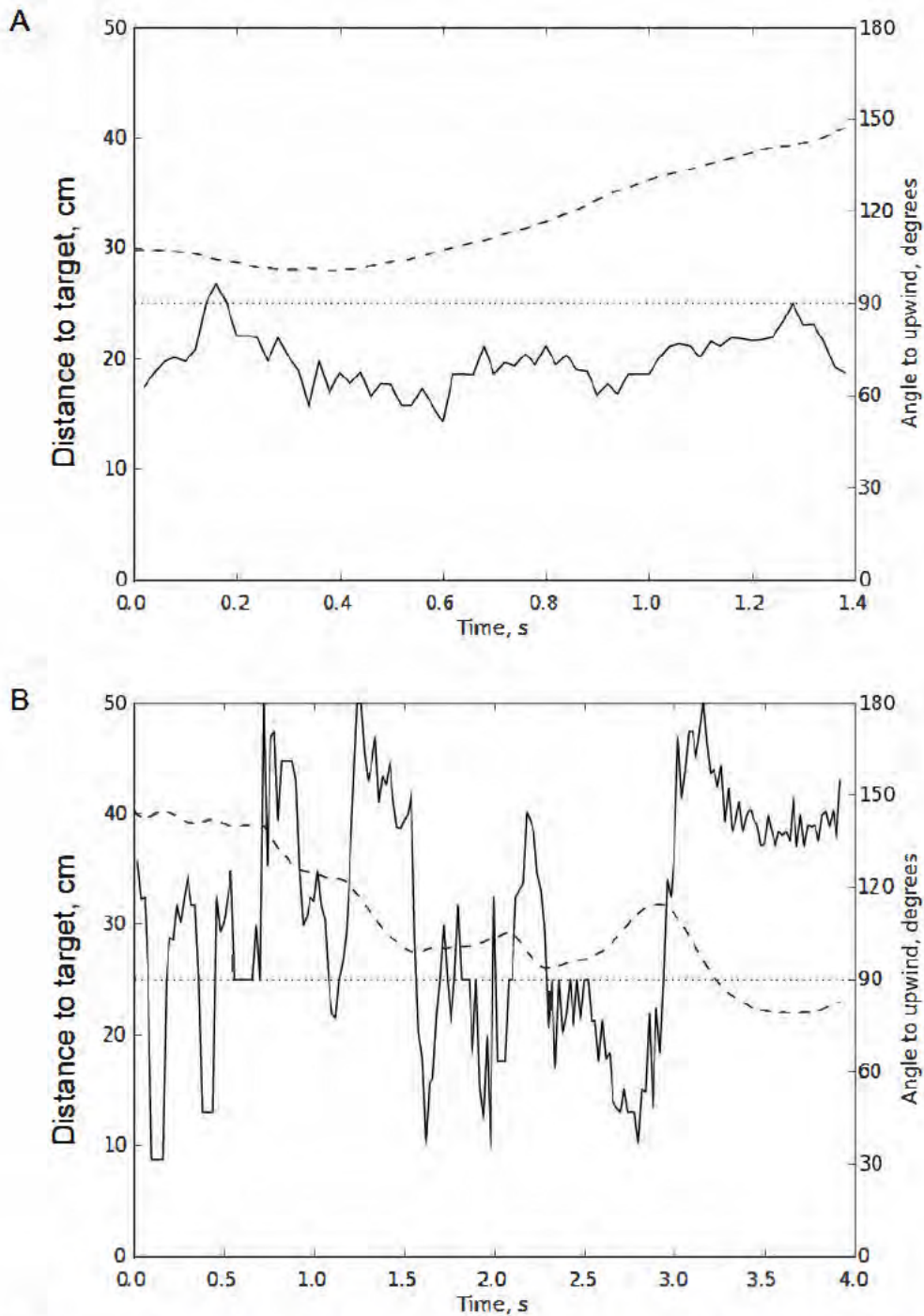
The three-dimensional position of a single flying mosquito was recorded at 20 ms intervals using Trackit3D (BIOBSERVE GmbH, Germany) tracking system as described in Chapter 3 and 3D coordinate data were selected for analysis according to criteria described in Chapter 5. Tracks were then analysed in a custom-built Python script. Flight parameters are summarised in Table 6.1, Chapter 5.

### *Spatial distribution of tracks and relationship to visual cues*

Although some mosquitoes in all four assays flew past the targets, those that passed by the edge of targets maintained fairly consistent direction and tortuosity before and after passing by the track; that is to say, there was no evidence to suggest a behavioural response to either clear or black targets in mosquitoes that did not approach the target head on (straight towards its two dimensional surface). Tracks demonstrating a response to the target were defined as trajectories that progressed directly up or downwind toward the target's surface (xz-plane), reaching a minimum distance of  $\leq 15$  cm from the target, followed by a sharp change in angular velocity at their closest point to the target (i.e. turning through  $\geq 90^\circ$ , in time to avoid collision with the target). Only tracks fulfilling all of these criteria were considered to have responded to the targets. Figure 6.2 and Figure 6.3 show examples of track parameters meeting responding and non-responding criteria, respectively (see also Appendix B: Supplementary material 6a). Responding flight tracks were further categorised according to direction, as approaching the target up-, down- or crosswind (as defined in Chapter 5, Figure 5.2).



**Figure 6.2 Example tracks reaching the minimum distance from the target ( $\leq 15$  cm) required to satisfy 'response' criteria. Solid line is angle to due upwind ( $0^\circ$ ); dashed line is distance to target. Solid line crossing the dotted line ( $90^\circ$ ) represents changing between up and downwind directed flight. (A) demonstrates the large and rapid change in direction at minimum distance from the target used to quantify responses; (B) closely approaches the target, however its direction remains largely unchanged and is therefore considered not to respond to the target.**



**Figure 6.3 Example tracks not reaching the minimum distance from the target ( $\leq 15$  cm) required to satisfy response criteria. Solid line is angle to due upwind ( $0^\circ$ ); dashed line is distance to target. Crossing the dotted line ( $90^\circ$ ) represents changing between up and downwind directed flight. (A) shows a steady upwind heading away from the target; (B) demonstrates a tortuous track, with repeated changes in direction relative to upwind, but remaining at distance from the target.**

Tracks were grouped as responses or non-responses for each of the four assays. To see the general pattern of how flight behaviour changed as mosquitoes approached then flew away from targets in each of the assays, means of the track speed, 3d angular velocity and velocity in x, y and z were calculated at 20 ms intervals from 0.5 s before until 0.5 s after tracks reached their minimum distance from the target.

### *Statistical analysis*

To explore the effects on activation (as defined in Chapter 6.2.6) of odour treatment and the presence and absence of both clear and black targets, a binomial generalized linear model (logit link) was computed using activation data from this experiment, alongside that from the experiment described in Chapter 5, where activation was recorded in clean air and host odour treatments, but no targets were present. This was followed with Tukey honestly significantly different post hoc testing for differences between treatments. Differences in the number of tracks demonstrating a response to the target in each of the four assays were compared with Fisher's exact test. Mean minimum distances to targets were checked for normality graphically (Q-Q plots and residuals versus fitted values) and statistically (Shapiro-Wilk test of normality), followed by one-way analysis of variance. All statistical analysis was undertaken in R statistical software (R Development Core Team, 2010).

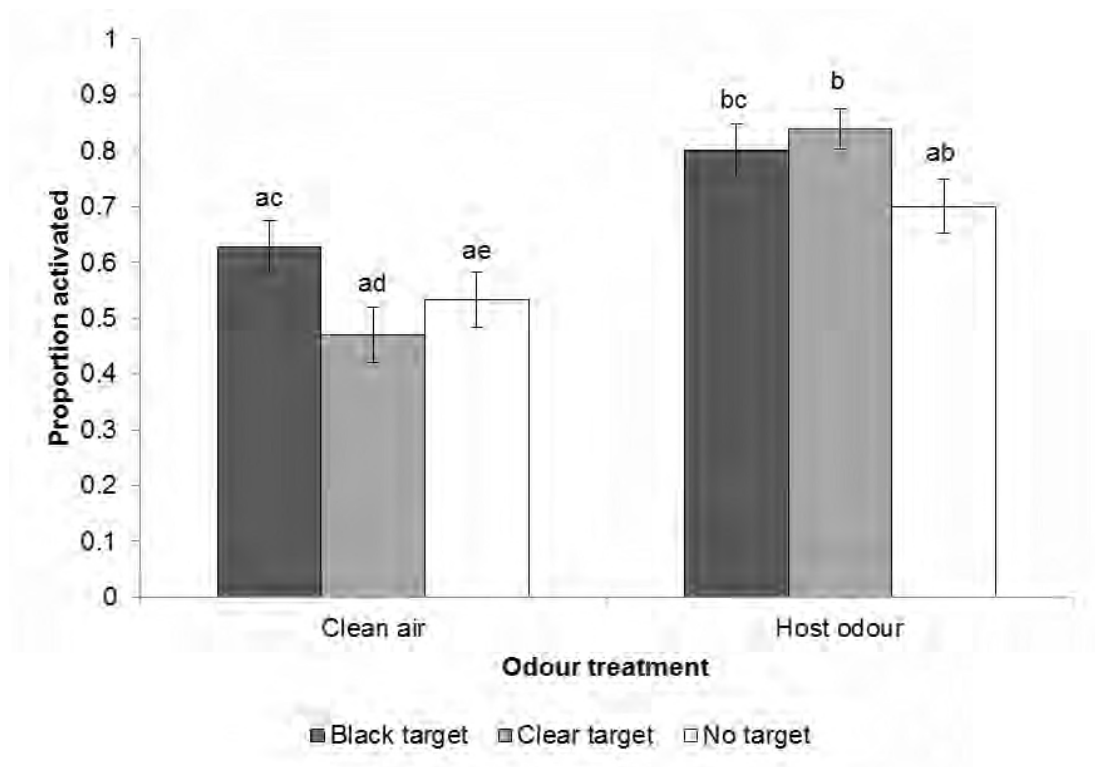
## **6.3 Results**

An overview of assays and data collected is shown in Table 6.1.

### *6.3.1 Activation*

Host odour significantly increased the proportion of *An. gambiae* that flew out of the release cage (Figure 6.4, including data from Chapter 5) from 47% to 84% in clear target assays, and from 63% to 80% in black target assays (binomial GLM,  $P < 0.05$ ). There was no significant difference in activation

between clear or black target assays when host odour was present, nor when it was absent. When compared against data from Chapter 5, there was no significant difference in activation against clean air assays with no target (50%) and no significant difference against host odour assays with no target (48%). Thus, olfactory cues appear to play an exclusive role in increasing activation in *An. gambiae*.



**Figure 6.4** Proportion of mosquitoes activated in clean air and host odour during assays with either a clear or black target present in the centre of the flight arena, plus activation results when no target was present from experimental data presented in Chapter 5,  $\pm$ SE. Different letters denote significant differences within and between treatments (binomial GLM, Tukey linear hypothesis testing,  $P < 0.05$ ).

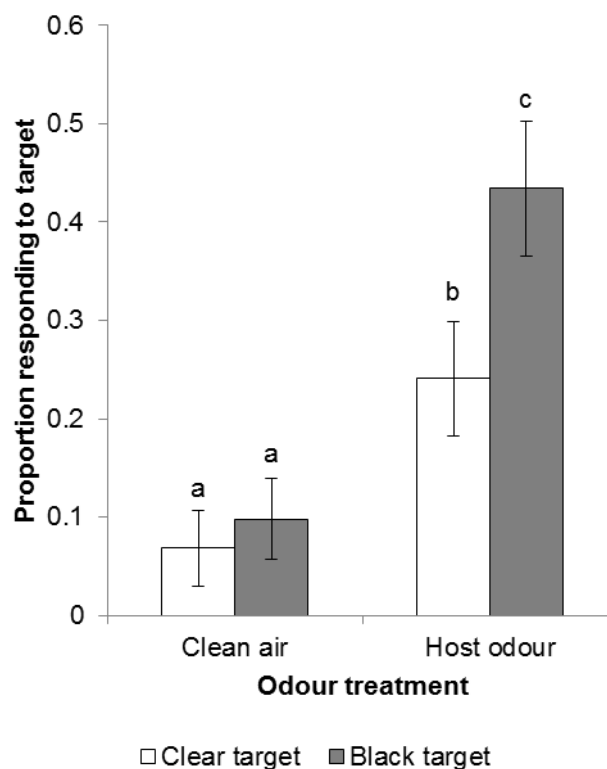


**Table 6.1 Summary of data collected during target response assays in clean air and host odour with a clear target and a black target.**

Odour treatment	Target type	No. assay replicates	Total no. insects released (N)	No. of tracks	No. data points analysed	Mean track duration $\pm$ SE, s	Mean errant points $\pm$ SE, %
Clean air	Clear	20	100	44	4130	1.8 $\pm$ 0.1	13.1 $\pm$ 1.1
Clean air	Black	21	105	51	4618	1.8 $\pm$ 0.1	12.0 $\pm$ 0.9
Host odour	Clear	21	105	54	5381	2.0 $\pm$ 0.1	10.6 $\pm$ 1.3
Host odour	Black	14	70	53	5178	1.9 $\pm$ 0.1	15.0 $\pm$ 1.0

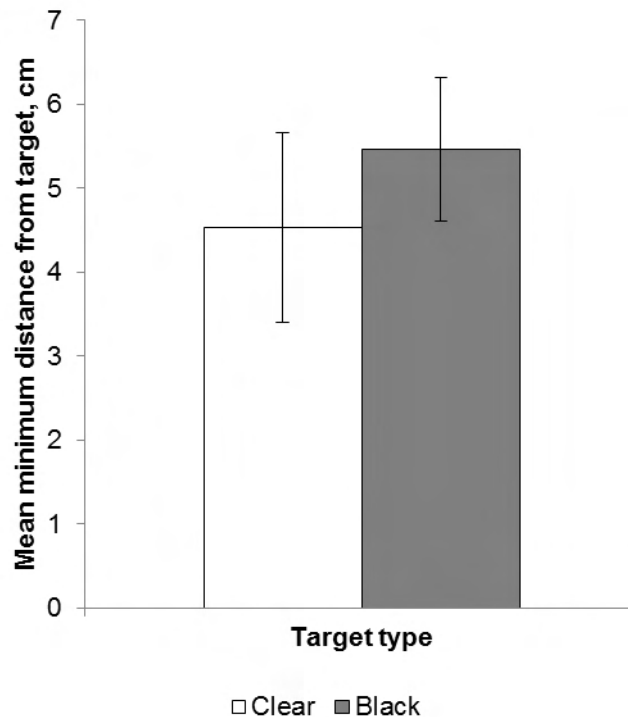
### 6.3.2 Responses to targets

When host odour was present, there were significant differences in the number of mosquito tracks responding to clear (13 out of 54 tracks) and black targets (23 out of 53 tracks; Figure 6.5). For black target assays, a greater number of mosquitoes demonstrated a response to the black target in host odour (23 out of 53 tracks) than in clean air (5 out of 51 tracks) (Fisher's exact test,  $P < 0.001$ ). Of those host odour tracks in which a mosquito showed a target response, only one out of 23 approaches was crosswind, with the remaining tracks split quite evenly between upwind (12 tracks) and downwind (10 tracks) approaches. Of the five responding tracks observed in clean air, all approached the target in an upwind direction.



**Figure 6.5** Proportion of tracks showing responses to clear and black targets in the absence or presence of host odour,  $\pm$ SE. Different letters denote significant differences within and between treatments (Fisher's exact test,  $P < 0.05$ ).

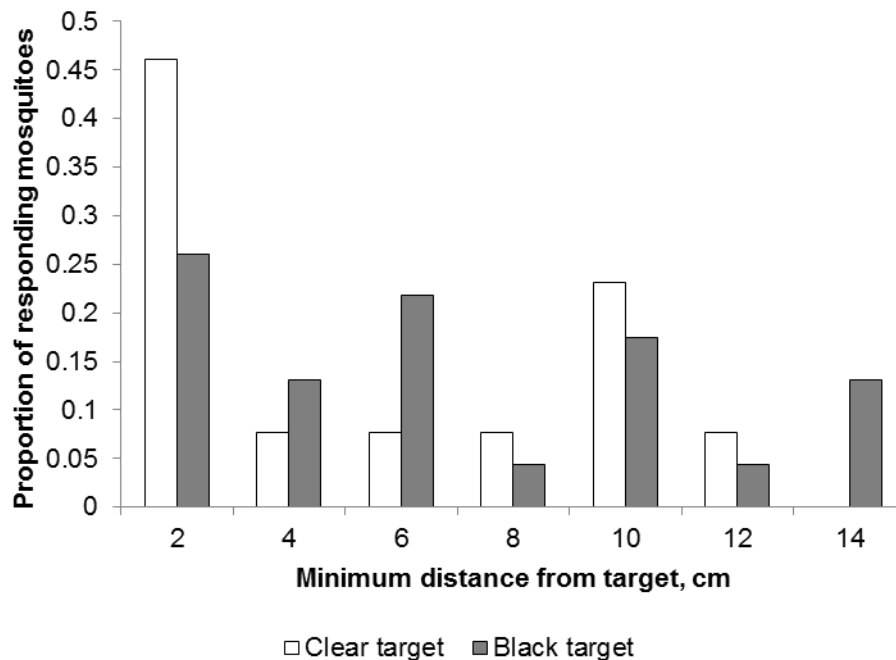
The number of clear target responses in the presence of host odour was significantly greater than in clean air (3 out of 44 tracks; Fisher's exact test,  $P < 0.05$ ). There was no significant difference in the number of responses to black (5 out of 51 tracks) or clear (3 out of 44 tracks) targets in clean air (Figure 6.5). Furthermore, mosquitoes were never recorded or observed contacting or landing on either target in either odour treatment.



**Figure 6.6 Mean minimum distance to clear and black targets of mosquitoes responding to targets in the presence of host odour,  $\pm$ SE. Difference is not significant (One-way ANOVA).**

Although a significantly greater number of mosquitoes showed a response to the black target compared to the clear target during host odour assays (Fisher's exact test,  $P < 0.05$ ), there was no significant difference in the mean minimum distance to either target reached by responding mosquitoes (Figure 6.6). It is apparent from Figure 6.7, however, that mosquitoes responding to the black target executed avoidance turns at a range of

minimum distances from 2 – 14 cm, whereas > 45% of avoidance behaviour in response to the clear target happened within only 2 cm of the target's surface.



**Figure 6.7** Frequency histogram of minimum distance to clear and black targets of mosquitoes responding to targets in the presence of host odour.

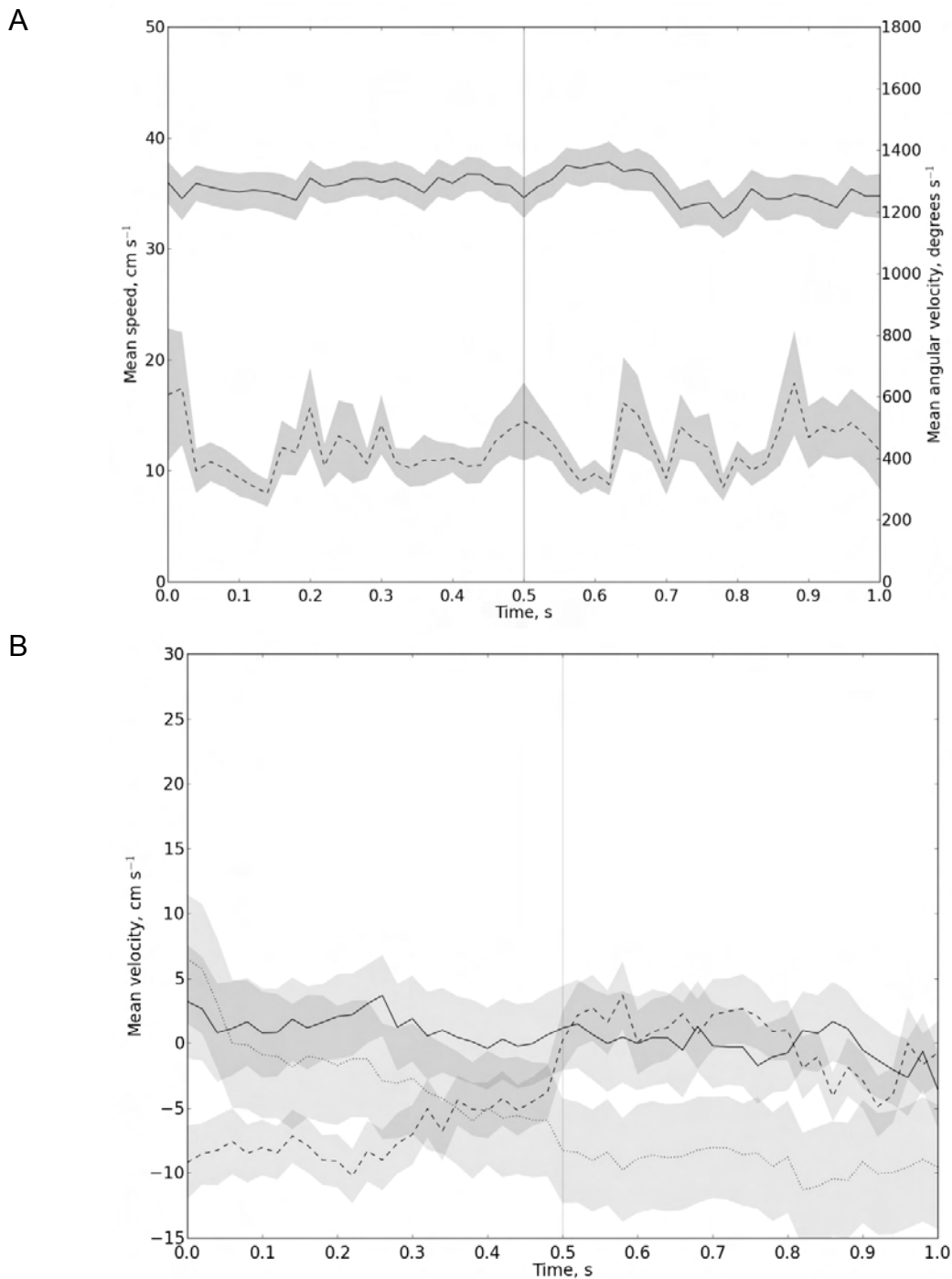
### 6.3.3 *Flight parameters around targets*

Mean flight parameters were calculated from 0.5 s before until 0.5 s after tracks reached their minimum distance from the targets. Mean speed and angular velocity of tracks from clean air assays which did not respond to the black target show a consistent range of values, both when moving around the black target and when they are at their closest point to it (Figure 6.8 A). Little variability is seen in the velocity of non-responsive tracks before and after reaching their closest distance from the target (Figure 6.8 B). The presence of host odour alters these flight parameters, however, as tracks responding to the black target decrease in speed ~ 0.04 s before reaching their closest point from the target (Figure 6.9 A). Their slowest speed

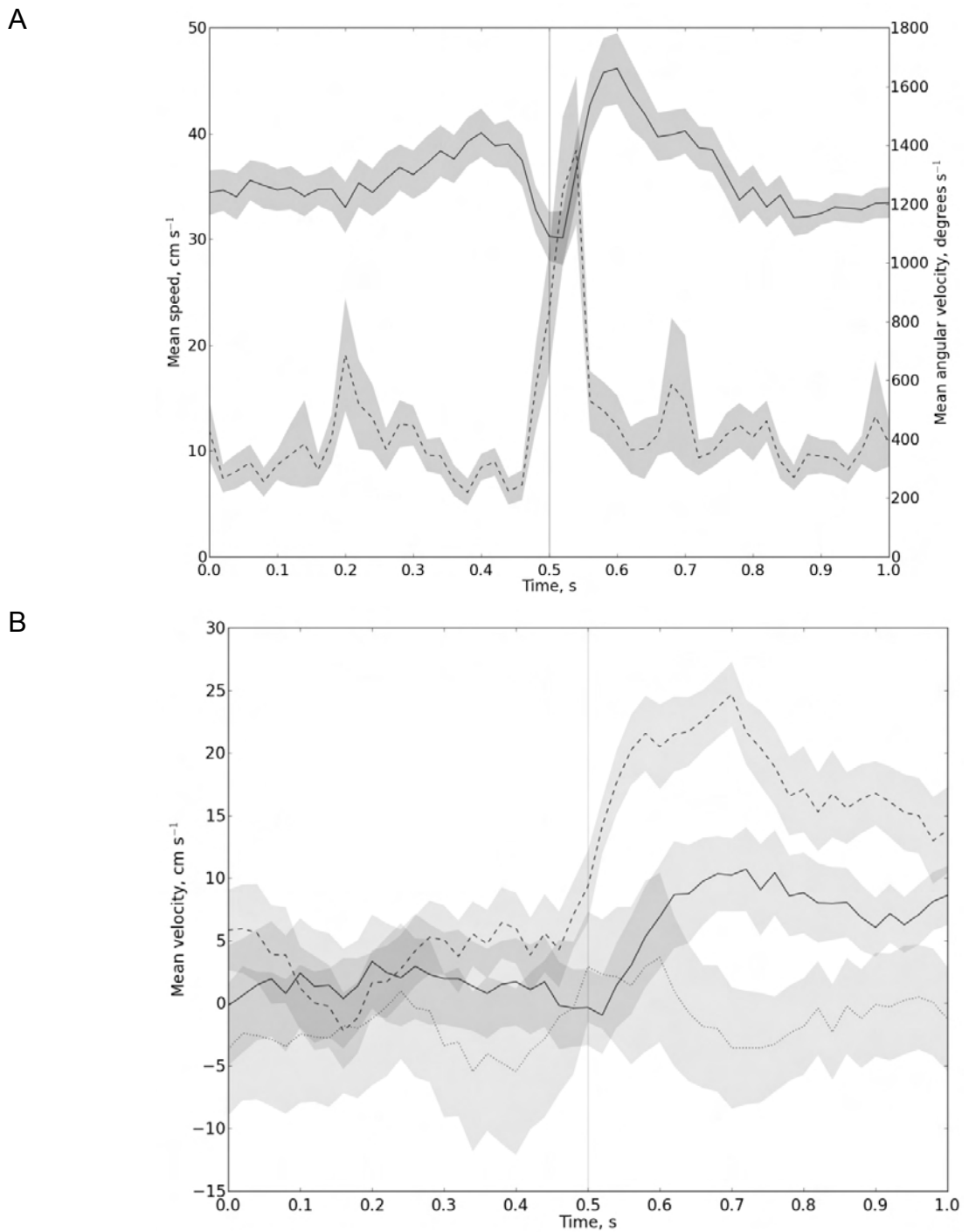
coincides with their closest point to the target, after which speed increases for  $\sim 0.08$  s as mosquitoes move away from the target. Angular velocity is also seen to change over the same timeframe as speed, increasing more than five-fold between 0.04 s before and 0.04 s after the tracks' closest point to the target, before returning rapidly (within 0.02 s) to a level comparable to that of the approach to the target. When the same data are considered in terms of mean velocity in each direction (x, y and z, Figure 6.9 B), the majority of the observed changes occur in vertical displacement, i.e. height above the floor (z-axis), which corresponds with mosquitoes ascending away from the target once they reach their closest point to it.

There are points of similarity and difference between the flight parameters of mosquitoes responding to the black target and the clear target. Non-responding insects in clean air show similar flight profiles, in terms of speed, angular velocity (Figure 6.8 A and Figure 6.10 A) and velocity (Figure 6.8 B and Figure 6.10 B), regardless of target type, although tracks from clear target assays have more variability over time in their angular velocities.

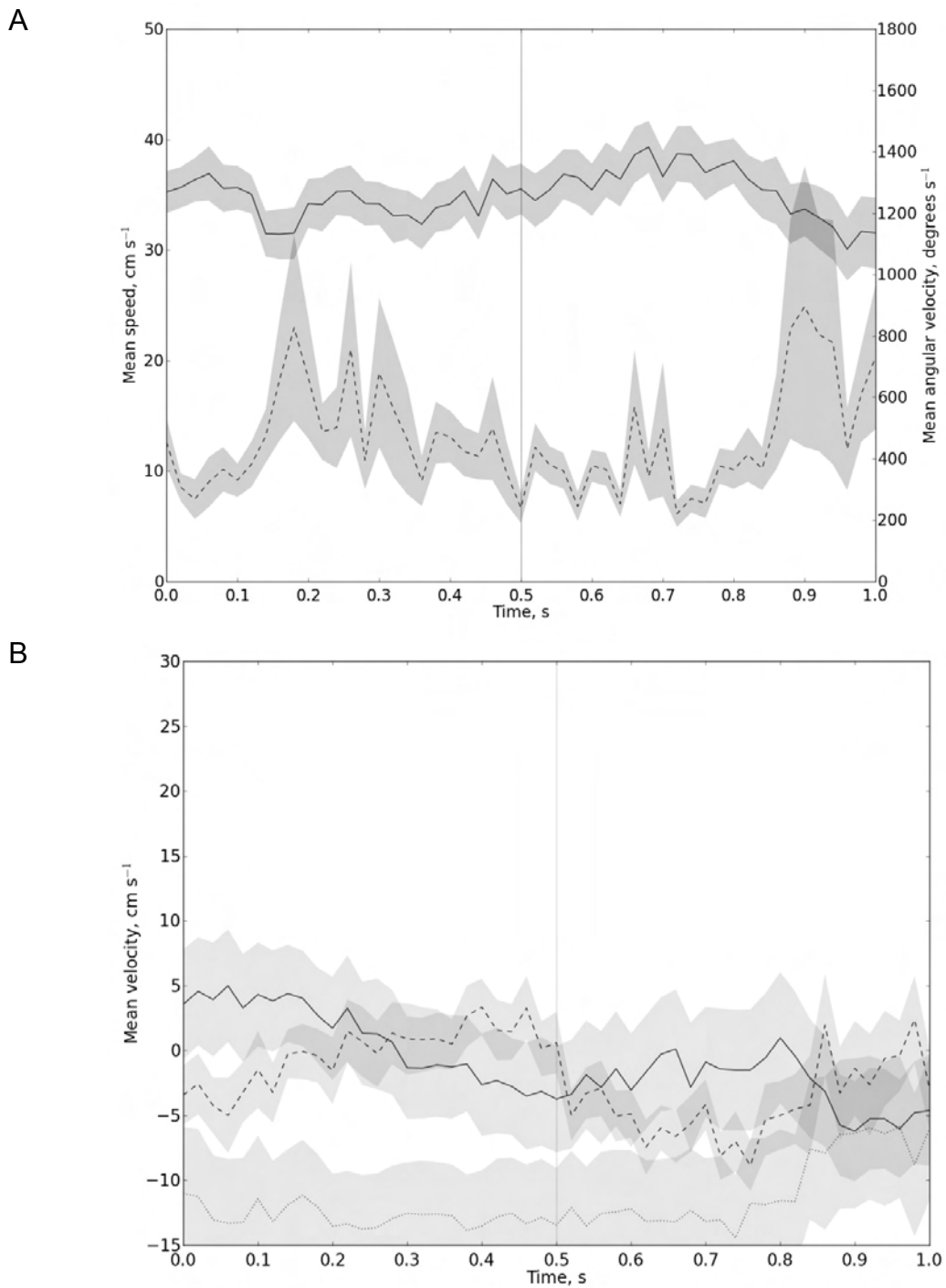
In host odour treatment conditions, mosquitoes responding to either black or clear targets reach similar peak mean angular velocities (black target:  $1383 \pm 259$  °s, clear target:  $1350 \pm 388$  °s; ANOVA,  $F = 0.005$ , d.f. = 1,  $P > 0.9$ ) at the same time relative to their closest approach to the target (0.04 s after reaching closest point to the target). However, mosquitoes begin to increase their angular velocity 0.02 s before reaching their closest point to the black target (Figure 6.9 A), whereas those responding to the clear target begin to increase their angular velocity only once they reach their closest point, and reduce their flight speed more slowly (Figure 6.11 A). Clear target responses also lacked the sudden change in vertical displacement (Figure 6.11 B) seen in interactions with the black target (Figure 6.9 B), demonstrating instead a gradual increase in crosswind and vertical displacement.



**Figure 6.8 Mean flight parameters of mosquitoes not responding to the presence of a black target in clean air.** (A) Mean speed (solid line) and mean angular velocity (dashed line)  $\pm$ SE. (B) Mean velocity in x (crosswind; solid line), y (up/downwind; dotted line) and z (vertical, dashed line)  $\pm$ SE. Vertical line at 0.5 s indicates where tracks are at their closest to the target. Minimum N = 25.

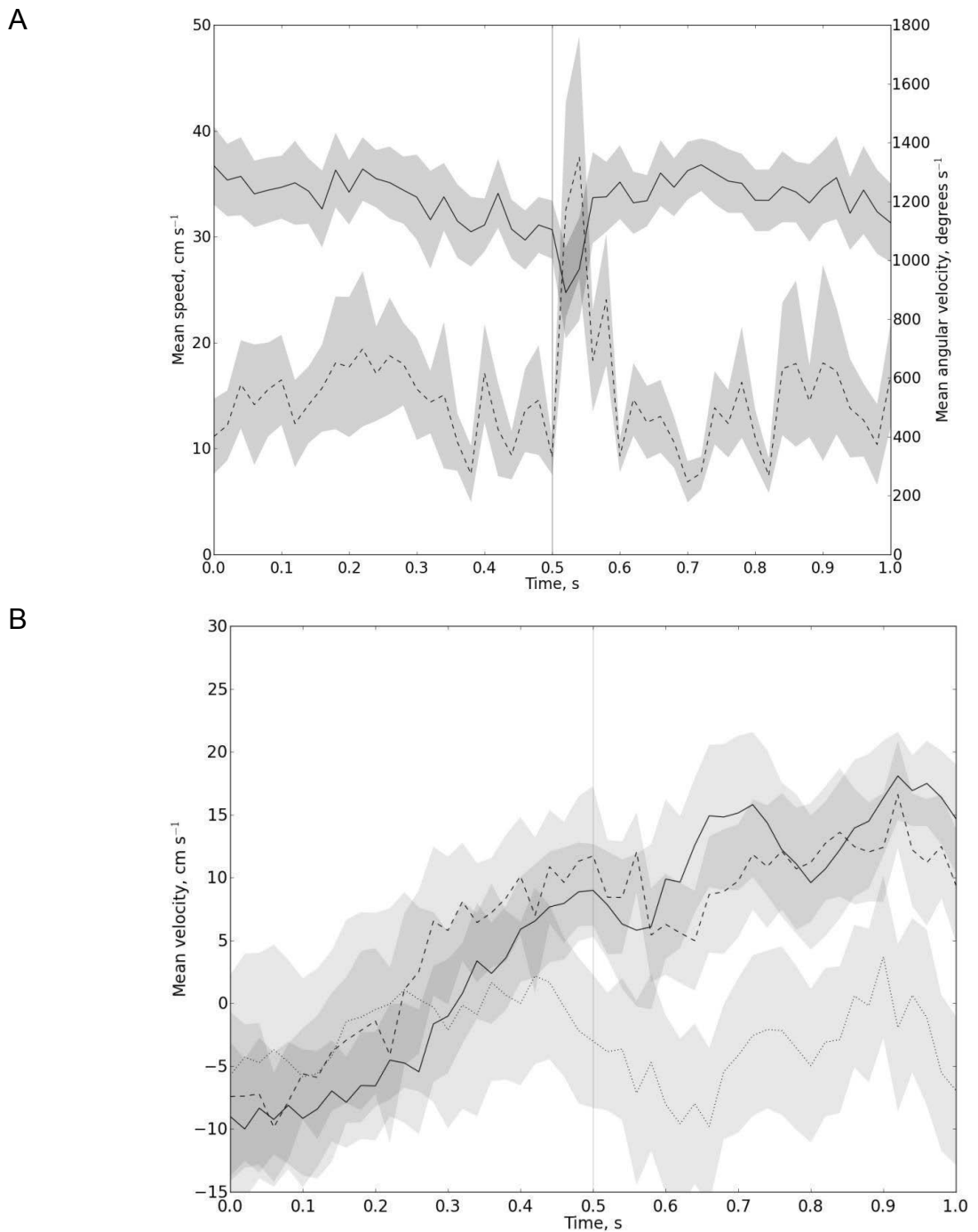


**Figure 6.9 Mean flight parameters of mosquitoes responding to the presence of a black target in host odour. (A) Mean speed (solid line) and mean angular velocity (dashed line)  $\pm$ SE. (B) Mean velocity in x (crosswind; solid line), y (up/downwind; dotted line) and z (vertical, dashed line)  $\pm$ SE. Vertical line at 0.5 s indicates where tracks are at their closest to the target. Minimum N = 21.**



**Figure 6.10 Mean flight parameters of mosquitoes not responding to the presence of a clear target in clean air. (A) Mean speed (solid line) and mean angular velocity (dashed line)  $\pm$ SE. (B) Mean velocity in x (crosswind; solid line), y (up/downwind; dotted line) and z (vertical, dashed line)  $\pm$ SE. Vertical line at 0.5 s indicates where tracks are at their closest to the target. Minimum N = 20.**





**Figure 6.11 Mean flight parameters of mosquitoes responding to the presence of a clear target in host odour.** (A) Mean speed (solid line) and mean angular velocity (dashed line)  $\pm$ SE. (B) Mean velocity in x (crosswind; solid line), y (up/downwind; dotted line) and z (vertical, dashed line)  $\pm$ SE. Vertical line at 0.5 s indicates where tracks are at their closest to the target. Minimum N = 10.

## 6.4 Discussion

The results presented here quantify, for the first time, behavioural flight responses in *An. gambiae* to visual stimuli that are modulated by host-associated olfactory cues. Furthermore, a similar odour-modulated response is observed when a transparent, but otherwise identical, physical stimulus is presented in the same olfactory environment.

### *Activation*

In accordance with results reported in Chapter 5, host-associated olfactory cues in the moving air stream significantly increase activation from the levels seen in clean air. Neither the black target nor the clear target had a significant effect on activation in clean air or host odour assays; the presence of olfactory cues was the only factor to increase activation.

The current experiment did not set out to test the effect of visual and physical stimuli on activation in *An. gambiae*, so the size and position of these stimuli were not optimised to that end. However, based on minimum interommatidial angles of  $6.5^\circ$  representing the sampling density of *An. gambiae* eyes (Land et al., 1999), a stationary, light adapted *An. gambiae* facing the 20 cm wide black target straight on would be able to resolve it at  $\sim 190$  cm distance. In a completely dark adapted eye, where the resolvable angle is around  $40^\circ$  (Land et al., 1997), this distance drops to  $\sim 27$  cm. These calculations only give an approximate indication of how far away *An. gambiae* may be able to resolve the target, as they are based on a simplification of a complex, imperfect visual system. Light-dark adaptation in mosquito eyes can take between 40 min and several hours (Clements, 1999); as test mosquitoes were used in the first part of the subjective night, it is not possible to say how dark adapted their eyes had become. Therefore, given these limitations and considering the dimensions and lighting conditions of the wind tunnel, it is possible, although unlikely, that test mosquitoes may have been able to fully resolve the black target from the release cage, located  $\sim 180$  cm from the target position. Given the low light levels in the wind tunnel, it is most likely

that the dark target was detected by mosquitoes only once they had become active and flown to within ~ 50 cm of the target.

It would be of interest to determine whether spontaneous and/or odour-induced activation could indeed be increased with the presence of conspicuous vertical visual cues, in addition to the horizontal cues often added to the floor of wind tunnel environments. *Drosophila melanogaster* express differential flight behaviour in attractive odours depending on the visual features of the surrounding landscape, with vertical patterns thought to assist in flight stabilization and modulation of collision distance (Frye et al., 2003) and host-associated olfactory cues have been shown to increase activity levels in *An. gambiae* (Chapter 4, Hawkes et al., 2012). Provision of conspicuous vertical patterns resolvable by mosquitoes within the release cage, should be tested to determine whether they influence activation and flight behaviour in mosquito species.

#### *Responses to visual and physical stimuli*

The results demonstrate that olfactory cues from a whole host modulate a responsiveness in *An. gambiae* to visual cues that is not evident in clean air alone. Females fly within ~ 15 cm of a black target and then rapidly turn away from it by flying upwards. This behaviour is almost entirely absent in clean air. The observation that individuals rarely approach the black target in clean air fits with observations from other insect taxa, where rapidly expanding visual stimuli, in the absence of other sensory cues, will often indicate an impending collision with the source of visual expansion and trigger an avoidance response (Egelhaaf & Kern, 2002; Maimon et al., 2008; Reiser & Dickenson, 2010).

The anthropophilic and endophilic habits of *An. gambiae* s.s. (Costantini et al., 1998a; Pates et al., 2005) might lead one to expect *An. gambiae* to be attracted to conspicuous objects because they might be the surface of a potential host, or an indication of an opening through which the host odours

may be emanating. It is possible that a conspicuous visual cue, once detected in conjunction with the requisite olfactory profile, could result in motor output that anticipates contact with either a surface, such as a host's body, or a void, suggestive of a point of entrance to a structure. The characteristics of flight tracks described here suggest that mosquitoes in host-odour permeated air are initially attracted to the black target, but lack the presence of cues required to land, despite approaching the surface of the target.

Temperature and humidity gradients have been cited as likely close-range cues for mosquitoes orienting towards a prospective host (Eiras & Jepson, 1994; Takken et al., 1997b) and it is possible that if black targets were approached as potential odour sources, landing would not be attempted in their absence. No females were recorded contacting either target, regardless of the presence of host-associated odours. *Culex quinquefasciatus*, however, land more on warm glass beads that have been in contact with human feet than clean beads or those augmented with carbon dioxide (Lacey & Cardé, 2011). Perhaps the addition of non-olfactory close-range cues, such as increased temperature, could induce landing if mosquitoes were indeed investigating the black target as a potential host odour source.

After approaching the black target in odour, mosquitoes nearly always performed a steep, vertical ascent. This was not the case following odour-mediated approaches to the clear target. Unlike culicine mosquitoes, *An. gambiae s.l.* will more persistently attempt to enter houses through their eaves, when doors and windows are screened (Njie et al., 2009). Vertical flight at the interface with the black target could represent an odour-mediated response to structures, driving mosquitoes upwards towards the eaves of buildings. Alternatively, as *An. gambiae* are adept at avoiding host defensive behaviour (Lyimo et al., 2012), a change in direction, upwards and away from defensive actions, may be a reliable means to move out of the range of such host behaviour. Further studies are required to better elucidate these

potential functions and to discriminate between void entry, surface landing and collision avoidance behaviours.

Mosquitoes were found to avoid approaching the clear target placed in the middle of the flight arena, perpendicular to the direction of clean air, as often as they did near the black target. The addition of host odour resulted in mosquitoes responding to the clear target in a way superficially similar to their response to the black target, albeit significantly less frequently and with quantitative differences in flight parameters.

There are two remarkable implications of these observations. Firstly, they suggest the existence of a non-visual mechanism by which surfaces can be detected and consequently avoided, with the result that mosquitoes do not collide with objects lacking the strong visual features which might otherwise be used to predict and avoid collisions. Secondly, host-associated olfactory stimuli modulate this avoidance behaviour towards visually conspicuous and, to a lesser extent, transparent objects, implying a multi-modal fusion of vision, mechano-sensation and olfaction is involved in shaping the flight behaviour that leads mosquitoes to approach objects and potential hosts closely.

Sensory stimuli are integrated by the insect central nervous system to represent the external environment they sample and flight behaviour emerges from the resulting integrated motor output (Gomez-Marin et al., 2010). Certain components of the motor response can be suppressed and/or enhanced, depending on the physiological state of the insect and how the central nervous system responds to those stimuli at the time. This system serves to guide individuals towards physiologically relevant resources. Multi-modal sensory systems have been well studied in *D. melanogaster*. The response of interneurons involved in *Drosophila* visual-motion processing is doubled in flying individuals compared to those at rest (Maimon et al., 2010) and both visual feedback and wind-induced activation of mechanosensors in the Johnston's organ are necessary to initiate olfactory-driven odour tracking

(Budick et al., 2007; Duistermars & Frye, 2010). Furthermore, the fly brain is capable of differentiating signals from the Johnston's organ as either sound or wind, based on characteristic mechanical deformations in air particle movement within the fluid media (Atema, 1996; Yorozu et al., 2009). Multi-sensory integration of this kind is likely to occur across dipteran taxa and mosquito species have already been shown to use sound during flight to distinguish conspecific mates (Gibson & Russell, 2006; Pennetier et al., 2010).

The possibility of an additional role of the Johnston's organ for navigating surfaces when flying in moving clean and odour-laden air warrants investigation, as this sensory system could be capable of distinguishing reflected sound and/or variations in the air stream caused by the presence of obstacles. Budick et al. (2007) found that mechanosensory detection of wind stimuli reshaped *Drosophila* aversion to expanding visual stimuli. This is a necessary compromise if upwind flight is to be successful, as forward translation is also associated with an anterior focus of visual expansion. Insects still need to avoid collisions. This is achieved by an expansion avoidance behaviour whose strength is a function of the temporal frequency of visual expansion, wind velocity and position of the corresponding focus of contraction. The current experiment suggests in *An. gambiae*, a plume of host odour seems to suppress expansion avoidance, which is selectively favourable if mosquitoes are to ever approach human hosts or domiciles.

Once an obstacle or host is closely approached, a large proportion of the anterior field of view will be occupied by it; the possibility of a physical component controlling close-range collision avoidance and landing must be considered. Although mean minimum distance from targets were not different between clear and black targets, the spatial spread of minimum distances from the black target suggests its visual expansion was sufficient to elicit avoidance, presumably because there were insufficient additional cues to indicate the presence of an obstacle. That the majority of minimum distances from the clear target were found within 2 cm of the target suggests an

alternative mechanism, not predicated on visual expansion, was sufficient to provide the cues indicative of surface collision. One possible means could be mechanosensory detection of changes in wind dynamics around the target; further details about the target's boundary layer and the small-scale eddies and vortices flowing around it could show whether sufficient information might be available to facilitate surface avoidance.

## 7 FIELD TESTING OF A NEW, VISUALLY CONSPICUOUS STICKY TRAP

### 7.1 Background

Understanding the behaviour and ecology of disease vectors is a key component of informed malaria control interventions. Of primary epidemiological importance is a reliable calculation of the entomological inoculation rate (EIR), defined as the number of infective bites received by one person in a single night. This is a function of the density of anopheline vectors relative to the human population, their human-biting rate and sporozoite rate (WHO, 1975); the resulting EIR serves as a valuable indicator of human-vector contact. Successful epidemiological surveillance of malaria transmission dynamics is, therefore, predicated on an ability to monitor the host-seeking population of anopheline mosquitoes with unbiased tools. These should allow us to determine population abundance, species composition, host preference, parasite infection rates, age-structure of a population and the spatio-temporal character of vector contact with hosts (Silver, 2008).

Human landing/biting catches are still largely considered the gold standard in mosquito monitoring, as their catches directly represent the number of mosquitoes contacting a human host. However, they are labour-intensive and so tend to be costly. They also depend to a large extent on the skills of the human collector and are ethically questionable, as collectors may be exposed to infective bites during the course of data collection (Silver, 2008). Although Gimnig et al. (2012) report that presumptive clearing of malaria infection with artemether-lumefantrine prior to, and chemoprophylaxis (atovaquone-proguanil) during the collection term result in collectors having a 96.6% lower incidence of malaria than non-collectors, they do not consider the presence of other mosquito-borne diseases. Simard et al. (2005) chose not to use human landing catches when sampling *Aedes albopictus* Skuse (Diptera: Culicidae) and *Ae. aegypti* because of the risk to collectors of dengue infection and the lack of an effective dengue vaccine or treatment.



Whilst there are currently no validated reports of artemisinin resistance in Africa (WHO, 2012), the emergence of drug resistant malaria in Asia (Fairhurst et al., 2012; Phyo et al., 2012) raises the prospect that human landing catches may cease to be an ethically viable means of monitoring mosquito populations.

Many of the alternative standard methods employed to monitor mosquito populations are considered to be inadequate, particularly for collecting outdoor biting mosquitoes. Even in their early use, Centres for Disease Control (CDC) light traps were shown to be far more effective at catching *An. gambiae s.l.* indoors, as opposed to outdoors (Odetoyinbo, 1969). Costantini et al. (1998b) found that the CDC light trap, whilst still widely used in mosquito surveillance, does not provide reliable data for estimating outdoor biting densities of African malaria vectors, because its catches do not correlate with human biting catches and are density-dependent in efficiency. Miniature CDC light traps are also considered to give an unreliable estimation of human biting rates compared to both indoor and outdoor human landing catches. During their use in Papua New Guinea, all mosquito species were found much less frequently in miniature CDC light traps than human-bait collections, with some species and physiological fractions of the anopheline population particularly under-sampled (Hii et al., 2000).

Despite the gains in reducing malaria morbidity and mortality achieved through intradomiciliary interventions, such as insecticide-treated bednets and indoor residual spraying (WHO, 2012), an increasing amount of malaria transmission is seen to be occurring earlier in the day and outside, whilst exophagic vectors, such as *An. arabiensis*, are increasingly responsible for transmission (Reddy et al., 2011; Russell et al., 2011; Yohannes & Boelee, 2012). Our present inability to sample vectors cheaply and ethically outside poses considerable challenges to our continued capacity to monitor vector populations and disease transmission (Govella & Ferguson, 2012).

Over the last decade, a number of projects have focussed on addressing these sampling inadequacies by developing novel catching devices that utilise whole human odour lures and can monitor malaria vectors outdoors. Various human-baited traps, including the Mbita bednet (Mathenge et al., 2002), Furvela tent trap and Ifakara A and B tent traps (Govella et al., 2009), have been shown to be poorly suited for outdoor sampling of malaria vectors; only one *An. gambiae* s.l. was caught in over 180 sampling nights by the Mbita trap either in or outdoors (Laganier et al., 2003; Mathenge et al., 2005). These traps are casually considered ‘outdoor’ traps because they can be deployed in the open; they all, however, essentially operate in a way very similar to the odour-baited entry traps (OBETs) of Costantini et al. (1993). For mosquitoes to be caught by these types of trap, they must demonstrate an entry response by flying into a collection chamber, much as in OBETs. It is perhaps unsurprising, then, that catches from Ifakara tent traps correlate better with indoor, rather than outdoor human landing catches (Govella et al., 2011). Yet, the designs of these new traps neither fully incorporate a strong entry response, nor represent attempts to exploit genuine outdoor host-seeking behaviour. As such, their outdoor performance is weaker than trapping methods that attempt to sample exclusively, but efficiently, either indoors or outdoors.

One possible tool that could be developed for sampling outdoor host-seeking mosquitoes is the sticky trap. As insects must land (or else passively blow) onto the surface of the sticky material, they represent a potential tool for exploiting landing, rather than entry responses. However, most existing sticky traps have been developed to catch ovipositing or emerging mosquitoes. Ovipositing allochthonous *Ae. albopictus* in Italy (Facchinelli et al., 2007; Marini et al., 2010), ovipositing *Aedes tremulus* Theobald (Diptera: Culicidae) and *Ae. aegypti* in man-made subterranean habitats in Australia (Kay et al., 2000), ovipositing *Ae. aegypti*, *Ae. albopictus* and *Culex* spp. in Thailand (Facchinelli et al., 2008), ovipositing *An. gambiae* in a semi-field system (Dugassa et al., 2012) and emerging adult *Cx. quinquefasciatus* and *Mansonia* spp. in north America (Slaff et al., 1984) have all been successfully

sampled by sticky traps. Despite focusing on less epidemiologically relevant fractions of the mosquito population, these studies demonstrate that sticky traps consistently preserve samples in a suitable condition for subsequent morphological and molecular identification, pathogen presence assaying, blood meal analysis and genotyping for insecticide resistant alleles.

Their simplicity of construction and use, low cost, portability and trapping efficiency make sticky traps an attractive option for more extensive vector monitoring operations. Furthermore, insects are trapped as soon as they alight, so the efficiency of a sticky trap is independent of the numbers of insects present; Gillies and Snow (1967), therefore, suggested their use as an objective monitoring tool in areas where baits may be quickly overwhelmed by high density populations.

A paucity of behavioural data pertaining to the role vision plays in nocturnal mosquito host location has resulted in few attempts to introduce visual cues into mosquito traps. Conversely, targets and baits for day-flying tsetse exploit an extensive understanding of their behavioural responsiveness to colour (Green & Flint, 1986), movement (Torr, 1988), shape and orientation (Tirados et al., 2011a). Perhaps human indifference to night vision has reduced research interest in this sensory modality for nocturnal disease vectors (Gillies & Wilkes, 1982). However, an original, but unpublished, experiment by R.P. Dow was reported by Bidlingmeyer (1994) in which the largest numbers of mosquitoes were caught by two visually conspicuous, but unbaited, traps placed a meter away from a transparent trap baited with carbon dioxide, suggesting mosquitoes were deviated towards visually conspicuous objects, even though they lay outside the odour plume. Furthermore, Bidlingmeyer and Hem (1980) demonstrate that there is competition between visually conspicuous traps and that nocturnal mosquito species not only use ground patterns, but also vertical visual cues, such as trees, to navigate through the environment (1979). This initial field data, coupled with the successful paradigm of tsetse control, hints at the potential for mosquito trapping success to be improved by incorporating quantified

responses to visual stimuli into trap designs. Based on these promising indications and the positive assay results reported in Chapter 6 that showed *An. gambiae* to be significantly more strongly drawn toward conspicuous objects when they are in a host odour plume, a new sticky trap for monitoring exophagic mosquitoes was designed and tested in the field. The aim of the field work presented here is to evaluate the potential role of the sticky traps as an outdoor monitoring tool.

## **7.2 Materials and methods**

### *7.2.1 Study site*

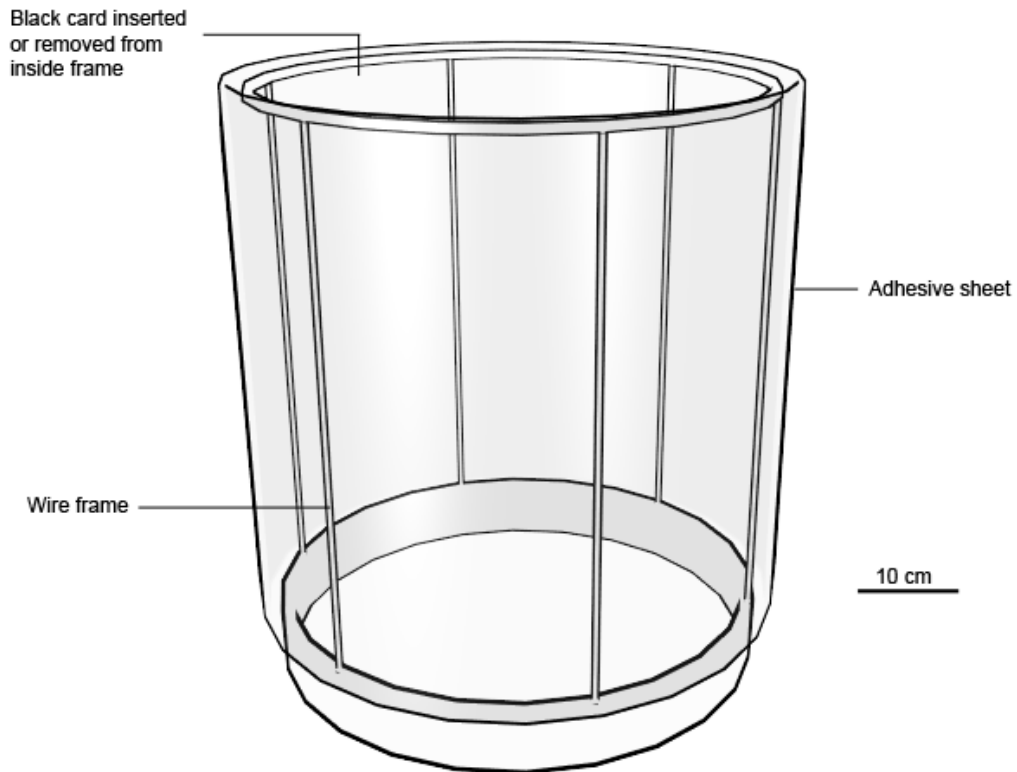
Field experiments were conducted in southwest Burkina Faso over seven nights at the end of the rainy season in October 2011. The study site is a research station located approximately 30 km north-north-west of Bobo Dioulasso on the outskirts of Bama village in Vallée du Kou (11°41' N, 04°44' W). Around 1200 ha of the surrounding area is given over to irrigated rice fields; this habitat is favoured by ovipositing M molecular form *An. gambiae* and they dominate local catches of *An. gambiae s.l.*, although the S molecular form does infringe from its rainfall breeding sites in the surrounding savannah (Baldet et al., 2003; Gimonneau et al., 2012). Only July and September are free from malaria transmission and approximately 90% of malaria cases in the area are caused by *An. gambiae s.l.*, stemming from an estimated 515 infected bites per man per year (Baldet et al., 2003). Multiple insecticide resistance is reported throughout the Vallée du Kou, attributed in part to the extensive use of agricultural pesticides (Dabiré et al., 2012).

### *7.2.2 Catching devices*

#### *Sticky traps*

A cylindrical sticky trap was constructed from a commercially available sticky insect trap material, consisting of a sheet of transparent plastic (120 x 40 cm) coated in a hot melt adhesive (FICSFIL, Barretine, Bristol, U.K.), wrapped

around a cylindrical metal wire frame (45 cm high, 38 cm diameter) with sticky surface facing outwards (Figure 7.1). Matte black card (240 gsm) was inserted (hereafter the black trap) or removed (the clear trap) to control the visual conspicuousness of the trap.



**Figure 7.1 Schematic of sticky trap design.**

### *Electric nets*

Initially developed for tsetse (Vale, 1974), electric nets (E-nets) stun or kill insects as they fly into a vertical bank of alternately charged or earthed wires, completing the electrical circuit between adjacent wires as they do so. E-nets used in this experiment were those typically used for tsetse sampling. Each consists of a square-section of aluminium tubing (25 mm dia) arranged to form a frame, 1m high and 50 cm wide, supporting a sheet of fine black polyester netting (quality no. 188; Swisstulle UK plc., Nottingham, U.K.), designed to prevent insects flying through two banks of copper wires

(0.2 mm in diameter, 8 mm apart), each positioned 8 mm away from and parallel to either side of the net. A DC transformer, powered by a 12 V battery, charges or earths the copper wires with ~ 70 Hz pulses of ~ 50 kV output.

E-nets were positioned ~ 15 cm to one side of sticky traps, approximately perpendicular to the prevailing wind direction (north east). Electrocutted insects were collected in water-filled trays containing a weak solution of ~ 5 ml detergent in ~ 1 L water positioned either side of the foot of the E-net. The detergent decreases the surface tension of the water thereby wetting insects that fall into the water tray and hence preventing their escape. The positioning of the trays gives an indication of the direction from which insects approach the E-net (i.e. up or downwind).

Although the true efficiency of a field trap cannot be known, E-net catches provide a measure of the number of mosquitoes that approach/circulate around the vicinity of the sticky trap. The sticky trap catch, as a proportion of the mosquitoes on the sticky trap and caught on the E-net, can then be viewed as an approximate indication of the efficiency of the sticky trap for trapping mosquitoes from all those circulating.

### *7.2.3 Odours*

Natural odours delivered to each trap were obtained from one man, who was drawn from a pool of three adult male volunteers, in a polyester (190T) tent (225 x 105 x 110 cm, Quick Pitch SS 2011; Gelert, Ijsselstein, Holland). It was not possible to weigh the individuals. The tent entrance was positioned 5 m upwind of catching devices and odour-laden air was drawn from the tent to a sticky trap via plastic tubing, 25 cm in diameter, using a 6 V fan from a miniature CDC light-trap (J.W. Hocke Inc., FL., U.S.A.). The net-covered exhaust of the plastic tubing rested ~ 15 cm upwind from the base of the sticky trap. Two tents were set up in this way, separated by 20 m crosswind and positioned ~ 300 m upwind from the edge of the village.

#### 7.2.4 Species identification

*Anopheles gambiae* s.l. caught on sticky traps were identified morphologically under a dissecting microscope; other anopheline mosquitoes were identified to genus only (Gillies & Coetzee, 1987; Gillies & de Meillon, 1968). Mosquitoes collected from trays beneath E-nets were identified to genus and, where possible, species (Walter Reed Biosystematics Unit, 2011). Only non-gravid females (WHO, 1975) were included in the analysis.

#### 7.2.5 Experimental design

Experiments were conducted between 20:00 and 06:00 h over seven consecutive nights, the sixth night of which coincided with a new moon (H.M. Nautical Almanac Office, 2011). One clear and one black trap were tested per night and their positions alternated between the two tents. At the end of each collection period the sticky material was wrapped in cling film (plastic/catering wrap), removed from the wire frame and stored in a -80° C freezer prior to species identification. E-net catches were collected at 06:00 h and stored in 70% ethanol. All batteries were recharged daily.

A sticky trap without an odour source was used to test whether the sticky material itself was attractive to mosquitoes. This was positioned ~ 100 m downwind of the odour-baited catching devices and tested on six nights, alternating between a clear trap and a black trap each night. It was not possible to provide this trap with an adjacent E-net.

#### 7.2.6 Statistical analyses

Mosquito catch was divided taxonomically into *An. gambiae* s.l., anopheline species (not including *An. gambiae* s.l.), and culicine mosquito species. The combined catch from sticky trap plus E-net provided the total catch; sticky trap catches were computed as a proportion of this total to provide a measure of their trapping efficiency. To determine the significance of the visual conspicuousness of sticky traps on their catch, and whether this

differed according to species, the total catch was subjected to a negative binomial regression (log link). The proportion of catch on a sticky trap was assessed for differences in catch by species and trap colour with a quasi-binomial model (logit link). General linear hypothesis testing was performed on both models using Tukey contrasts. Potential differences in E-net catch arising from direction and visual treatment were tested with two-way analysis of variance, as were differences between sticky traps, E-nets and human landing catches (HLC; these were provided courtesy of Institut de Recherche pour le Développement (IRD), see Results section). All statistical analysis was undertaken in R (R Core Development Team, 2010).

## 7.3 Results

### 7.3.1 Overview

Over seven nights, a total of 1892 mosquitoes were collected from all catching devices (Table 7.1). 77.5% of this was collected from sticky traps, the majority of which (70.3%) came from the black sticky trap.

**Table 7.1 Total mosquito collections from all clear and black sticky traps and E-nets, baited with human odour over seven nights in Burkina Faso.**

Visual treatment	Catching device	Odour	Total	Nightly mean	Standard error	Replicates
	Sticky trap	None	1	0.6	0.3	3
Clear	Sticky trap	Human	435	62.1	10.9	7
	E-net	Human	197	28.1	8.8	7
	Sticky trap	None	0	0.0	0.0	3
Black	Sticky trap	Human	1031	147.3	21.8	7
	E-net	Human	228	32.5	9.4	7

Besides *An. gambiae s.l.* (11.1%), other Culicid species identified in E-net catches were *An. coustani* Laveran (12.7%), *An. maculipalpis* Giles (1.1%),



*An. ziemanni* Grünberg (7.7%), *Mansonia uniformis* Theobald (13.8%) and *Mansonia africana* Theobald (13.4%), as well as individuals of genera *Aedes* (2.1%), *Culex* (0.9%), *Culiseta* (0.2%) and *Coquillettidia* (0.2%).

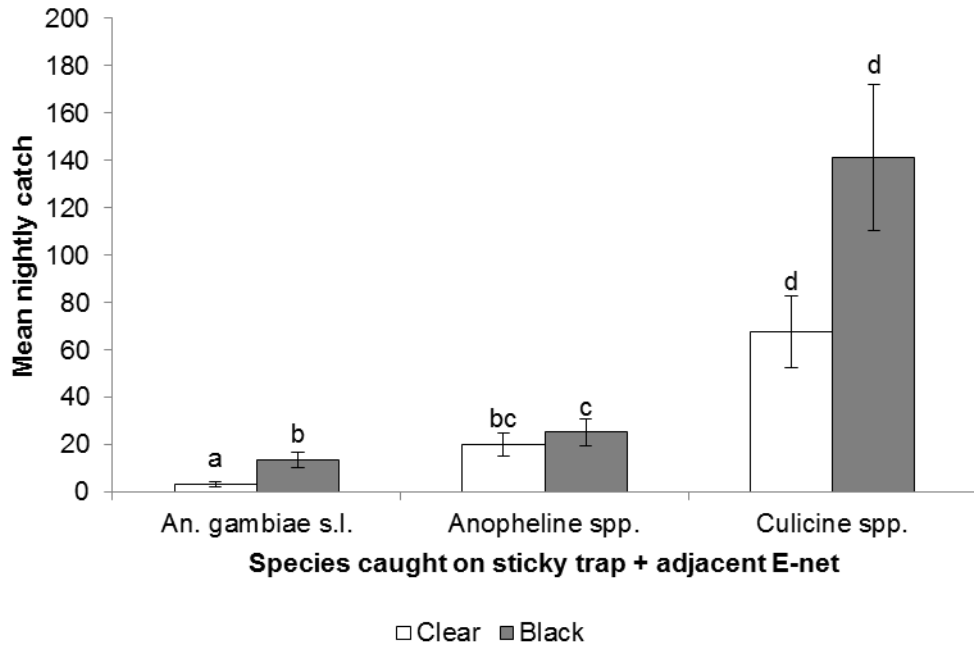
Although it was possible to identify the majority of the catch from genus *Anopheles* to species, 112 (48%) mosquitoes caught on E-nets and identified as *Anopheles* could not be further identified to species. This was due to samples losing morpho-taxonomical characteristics, in particular leg segments and wings. Mosquito legs without bodies were also occasionally observed on the adhesive surface of sticky traps, as some mosquitoes had apparently shed their legs whilst attempting to fly away after initial contact with the adhesive.

### 7.3.2 Control (no odour) sticky traps

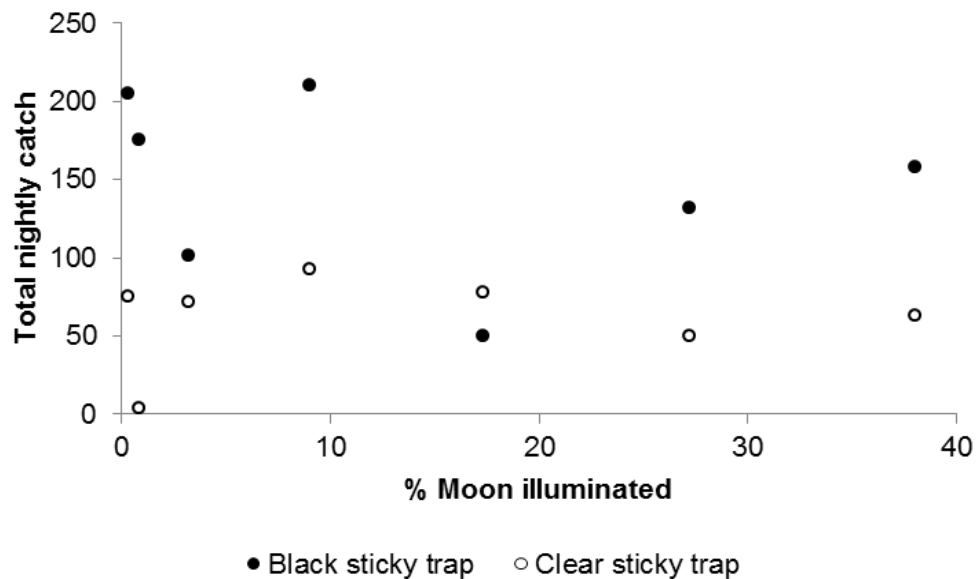
No host-seeking females were caught on black sticky traps in the absence of odour, whilst only one was caught on a clear sticky trap without odour. It therefore seems likely that the sticky material neither attracts host-seeking female mosquitoes onto its surface, nor traps excessive numbers of wind-borne mosquitoes colliding inadvertently with its surface.

### 7.3.3 Total catch

Of all mosquitoes caught by sticky traps plus E-nets, the majority were culicine species. Whilst the difference between mean catch differed significantly across all three taxa, there was no significant difference between the mean nightly catch on clear and black traps for anopheline or culicine species (Figure 7.2); however, the means for black traps were higher than for clear trap. However, the black trap and E-net collected nearly four times the mean nightly catch of *An. gambiae s.l.* compared to the clear trap (negative binomial GLM,  $P < 0.004$ ). Although there appeared to be greater variability in the nightly collections from black sticky traps than from clear sticky traps (Figure 7.3), total catches for both sticky traps do not show any clear relationship with moon phase.



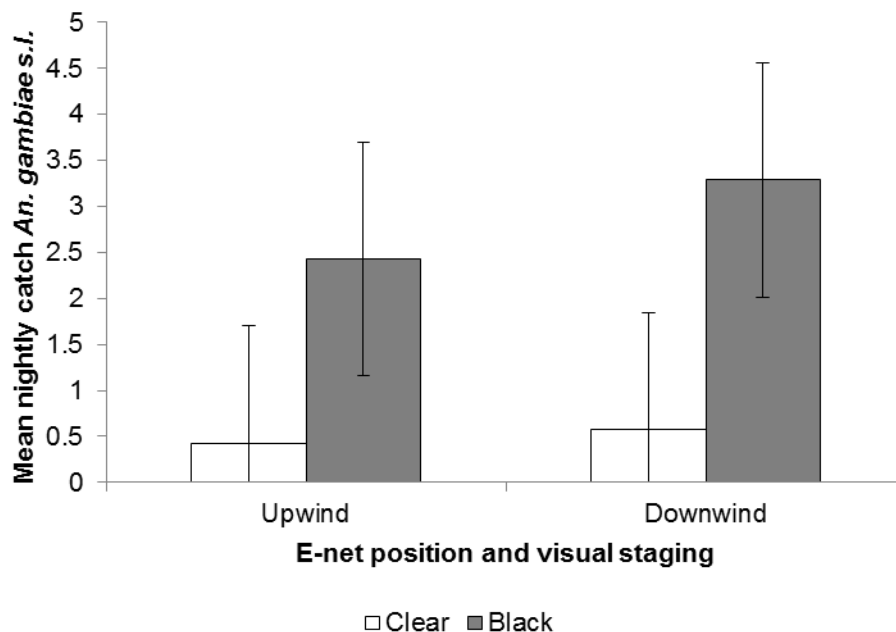
**Figure 7.2 Mean catches of mosquitoes for sticky traps plus their adjacent E-net,  $\pm$ SE.** Different letters denote significant differences (negative binomial GLM,  $P < 0.05$ ).



**Figure 7.3 Total nightly catches of mosquitoes for clear and black sticky traps in relation to visible fraction of the Moon's illuminated disk.**

### 7.3.4 E-net catches

Total E-net catches did not reveal a bias in the direction from which mosquitoes approached clear or black traps, in the catch between these traps, nor in the interaction between these factors. For *An. gambiae s.l.* specifically (Figure 7.4), no significant difference was found in their direction of approach to E-nets or in the interaction between direction and visual treatment. Although the mean E-net catch between clear and black visual traps and E-nets was not significantly different for either up or downwind catches (ANOVA,  $F = 3.4$ , d.f. = 1,  $P = 0.07$ ), it reflected the same trend of greater mosquito catches on black traps.

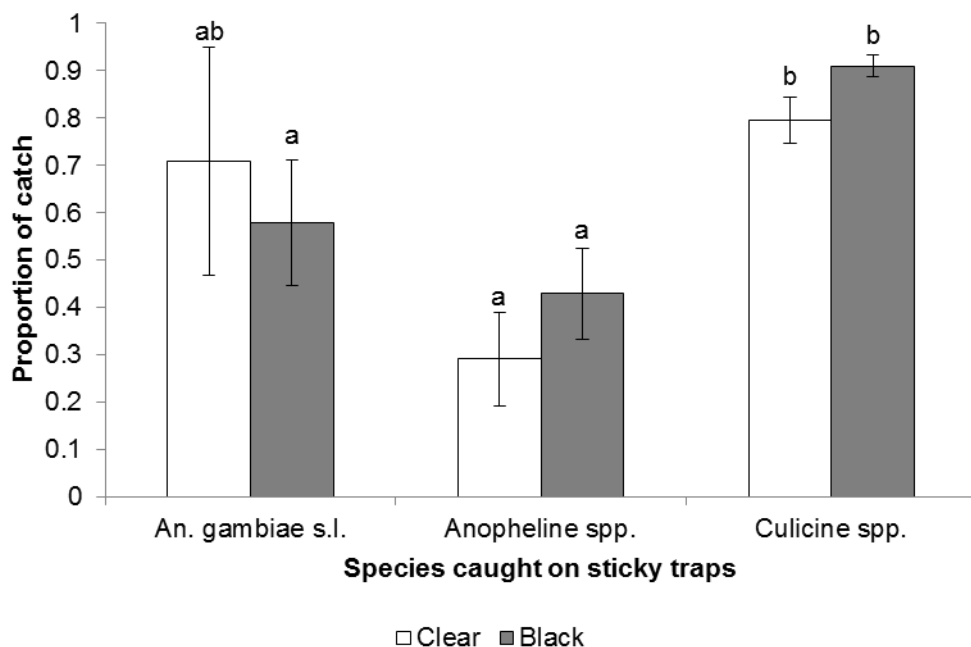


**Figure 7.4** Mean nightly catch of *An. gambiae* in up and downwind collecting trays for E-nets adjacent to clear and black traps,  $\pm$ SE. Differences are not significant.

### 7.3.5 Sticky trap efficacy

Catches for sticky traps were expressed as a proportion of the total catch from the sticky trap plus its adjacent E-net for each visual treatment, representing the efficiency of the sticky trap in collecting mosquitoes

circulating the vicinity of the catching devices. Despite the black sticky trap catching significantly more *An. gambiae s.l.* (N = 55) than the clear sticky trap (N = 17; Figure 7.2), their efficiencies were not significantly different (Figure 7.5); the clear trap was 70% efficient, whilst the black trap was 58% efficient. Culicine mosquitoes were collected more efficiently by both clear (80%) and black (91%) sticky traps compared to the efficiency with which anopheline species were collected (29% and 43% efficiency for clear and black traps, respectively; quasi-binomial GLM,  $P < 0.01$ ).

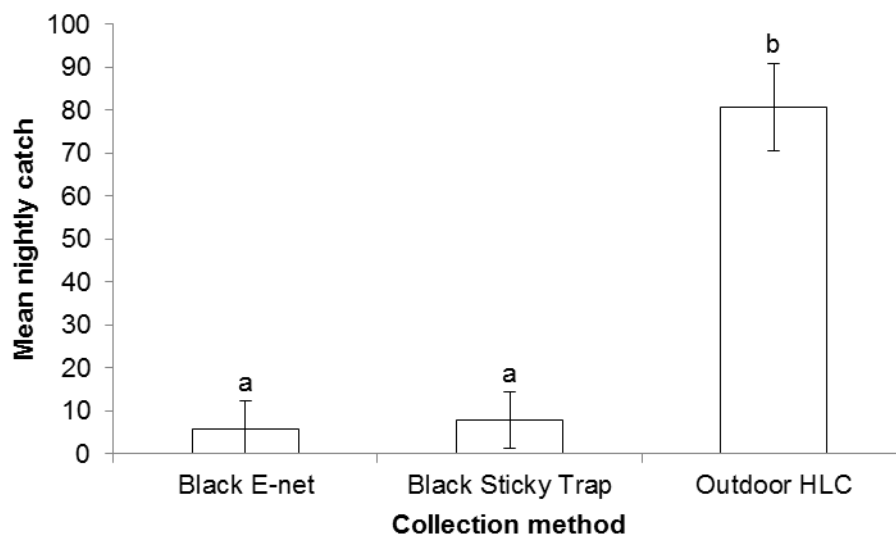


**Figure 7.5 Mosquito catch from sticky traps as a proportion of sticky trap plus E-net catch  $\pm$ SE.** Different letters denote significant differences (quasi-binomial GLM,  $P < 0.01$ ).

On the three consecutive nights immediately prior to the present experiment, the Institut de Recherche pour le Développement (IRD) conducted human landing catches (HLC) outside a hut located in the village of Bama. This data provides a useful addendum to the results from catching devices so far

presented. Hourly HLC collections began at 18:00 h and ceased at 06:00 h; only data from 20:00 h onwards has been reported here to correspond with the collection times used in the present experiment.

Black sticky traps and their corresponding E-nets performed about as well as each other in terms of mean nightly catch (Figure 7.6). As the gold standard for measuring vector-host contact, IRD's outdoor HLC resulted in approximately ten times the mean nightly catch of either black sticky traps or their corresponding E-nets (one-way ANOVA,  $F = 22.2$ , d.f. = 1,  $P < 0.001$ ).



**Figure 7.6 Mean nightly catch of *An. gambiae s.l.* from different collection methods  $\pm$ SE. Different letters denote significant differences (one-way ANOVA,  $P < 0.001$ ).**

#### 7.4 Discussion

There are a number of observations to be drawn from these results that are pertinent to both a broader understanding of host-seeking behaviour in *An. gambiae* and the development of behaviourally-guided monitoring tools for malaria vectors.

### *Visual conspicuousness and trap performance*

The black trap and its E-net caught significantly more *An. gambiae s.l.* than the clear trap and its E-net, indicating that the contrasting visual cues from the black sticky trap increased the number of mosquitoes attracted to the area immediately around the sticky trap. As no mosquitoes were caught on the control black sticky trap presented without odour, the enhanced attraction of the black visual cue appears to be entirely contingent on the concurrent presence of host odours.

These findings corroborate those observations made in the laboratory and used as the basis for including a visual component in the sticky trap design (see Chapter 6). In laboratory experiments, host-seeking female *An. gambiae s.s.* stimulated by human odour closely investigate a black target more frequently than they do a clear target, although they were never observed to land on either target. This suggests that the visual properties of the black sticky trap may act as attractive cues to *An. gambiae s.l.*, but do not necessarily increase the occurrence of landing behaviour on the trap itself.

Whilst odour plumes become narrower and shallower at close range, visual cues become more pronounced (Bidlingmeyer, 1994). So, successful medium to close range orientation could well be increased by switching to visually-guided object 'approach' behaviour, rather than object 'avoid' behaviour, when inside a host odour plume. Short range cues and their role in inducing landing responses on hosts are poorly understood, although body temperature and humidity gradients are implicated in this process (Eiras & Jepson, 1994; Takken et al., 1997b). Once suitable odours have been detected and a potential host sighted and approached, a hierarchical understanding of sensory succession would propose that detection of close range cues associated with convection currents would be necessary for landing and probing to commence. Far more empirical research is needed to quantify the role convection currents play in mediating landing behaviour,

particularly in warm, humid sub-tropical environments, if outdoor trapping tools are to be fully optimised.

Understanding why visual conspicuousness did not seem to have a significant effect on the catch of other mosquito species cannot be readily achieved with the present results alone and requires further investigation. The choice of experimental host odour will almost certainly have the greatest effect on the composition of mosquito species attracted to a catching device (Takken et al., 1997a; Costantini et al., 1998b; Dekker & Takken, 1998; van den Broek & den Otter, 1999; Torr et al., 2008). Given the range of host preference both within the *An. gambiae* complex and between other mosquito species caught (Clements, 1999), different results may be expected with different odour baits. Differences in the visual responsiveness of individual species may be obscured further by pooling catch results into anopheline and culicine categories. Experiments using odours from humans, common livestock animals and synthetic lures, alongside visually-baited sticky traps and E-nets, could provide interesting data regarding medium and close range host-seeking in anopheline and other disease-vectoring mosquito species.

#### *Trap efficacy*

The efficiency of clear and black sticky traps was not significantly different within species group. This implies that neither the black nor clear sticky traps were inducing more landing response in attracted mosquitoes than the other. The higher catch yielded by the black sticky trap appears to be a result of the greater number of mosquitoes attracted to the area, rather than a change in landing behaviour.

Black sticky traps and their corresponding E-nets were almost equally effective at trapping *An. gambiae*. This conforms with the results of Torr et al. (2008), who had success trapping *An. gambiae s.l.* on both E-nets and E-targets (an E-net with a black and phthalogen blue cotton sheet in place of

the polyester netting), and their ensuing supposition that *An. gambiae s.l.* alight on odour-baited targets.

Since E-nets are intended to provide a passive sample of the density of mosquitoes in the vicinity of the host odour source, the fact that they caught about 50% of the total catches suggests that there is much room for improvement in the efficiency of the sticky traps: only half of the available mosquitoes landed on the sticky traps, which means that the addition of close-range cues, such as increasing the temperature of the sticky trap or adding short-range volatiles and humidification of the odour stream might lead to significant increases in the proportion of the catch caught in the sticky traps. Furthermore, the size, shape and orientation of the visual cue might influence its attractiveness to mosquitoes, as it does for tsetse; these parameters should be investigated as cheap and easy means of optimisation. Once the design of the sticky trap has been optimised to catch the greatest proportion of mosquitoes present, the E-nets could be dispensed with and the new sticky trap could be calibrated against accepted standards, e.g. the outdoor human landing catch, and used to replace landing catches. Even if sticky traps, like CDC traps, catch fewer mosquitoes than an outdoor human landing catch, as long as there is a strong correlation between the two, in terms of the proportion of females caught in each physiological stage, age and infection status, then the sticky trap could replace human landing catches for standardised surveys.

Only one host-seeking mosquito was caught on control sticky traps, indicating that the sticky adhesive is not attractive to mosquitoes and does not appear to modify behaviour. Furthermore, the results are in accord with laboratory findings; mosquitoes that may fly close to visually conspicuous objects are able to avoid colliding with them or even evade landing on them when flying in a host odour plume, but the object itself does not emit short-range landing cues. They are also able to avoid transparent objects, despite their lack of the expansive visual cues often associated with avoidance. The precise optical properties of the sticky material should be studied to



determine whether they have any visual cues which could be perceived by mosquito species.

### *Effect of moonlight*

Provost (1956) found that catches from light traps varied inversely with the intensity and duration of moonlight, with the catch depressed because moonlight decreased the relative contrast of the light from the trap, rather than causing any physiological effect on mosquito behaviour. There is also some evidence to suggest the presence of moonlight brings biting behaviour forward to earlier periods of the night (Charlwood et al., 1986; Kampango et al., 2011). Whilst trap light seems to compete with moonlight, it would appear that the visual conspicuousness of hosts themselves is also mediated by moonlight. Charlwood et al. (1986) report larger human biting catches of *An. farauti* during moonlit nights, suggesting this species more frequently finds hosts when they are better illuminated, or else moonlight may help human collectors find landing mosquitoes more successfully.

The mechanical, rather than behavioural, efficiency of a visually conspicuous sticky trap that is based on providing dark, rather than light contrast, may also, therefore, be expected to vary according to moon phase. Percentage of moon illuminated (as presented in this study) provides only an indirect measure of the maximum moonlight available on a given night, rather than that actually reaching the ground. Although nights were subjectively considered to be clear, direct measurements of light levels at traps over a far more extensive period of sampling would be needed to gauge the effect, if any, of moonlight on visually-baited sticky trap performance.

### *Operational techniques*

Integrating visual cues into mosquito catching devices could prove a cheap and effective way of increasing the devices' catch. In one of the few experiments to investigate the difference in catch of host-seeking mosquitoes by visually dissimilar traps, Hauffe (1964) reported that those traps with

strong contrast were most successful; moreover, they were found to be equally efficient during both the day and night. This is likely because visual contrast remains identical during the day and night; only the mean light intensity differs (Warrant & Dacke, 2011). Visual contrast in a trap design could therefore increase a trap's attractiveness across all parts of the diel, making them of particular use for sampling continuously across the crepuscular transition from light to dark regimes. Unbiased catches from this period might be well-suited to monitoring the early-biting outdoor behaviour that is increasingly reported for *An. gambiae s.l.* (Reddy et al., 2011; Russell et al., 2011). Such traps would still require olfactory stimuli that could be sourced either from synthetic lures, providing a standardised odour composition (Okumu et al., 2010; Mukabana et al., 2012), or directly from residential dwellings, which have the potential to provide an abundant, albeit highly variable source of whole human odour for the cost of lay-flat tubing and a small battery-powered fan similar to a light trap fan (i.e. similar cost as indoor light-trap catches).

Although there was a spurious collection of wind-blown organisms, i.e. species that were not blood-feeders, as reported in other sticky trap designs (Slaff et al., 1984), control traps indicated that mosquitoes were not blown onto the trap. Interestingly, there was no greater number of mosquitoes in downwind E-net catches as might be expected if mosquitoes demonstrated the upwind plume-following approach that is widely accepted as the means by which mosquitoes (Lacey & Cardé, 2011; Dekker & Cardé, 2011) and other odour tracking insects (Gibson & Torr, 1999; Vickers, 2000) arrive at upwind odour sources. Perhaps E-nets were positioned too close to the sticky traps and so collected mosquitoes circulating the traps once they had already approached them; more comprehensive studies using a ring of E-nets (Vale, 1974) could elucidate this discrepancy. Directional data could be derived from the sticky trap by assigning sections of the cylinder to up and downwind, thus providing data about the approach mosquitoes take to the trap with respect to wind and/or odour source.

Electrocuting nets were originally designed as an unbiased tool which could be employed to better understand the relative importance of visual and olfactory stimuli in host-seeking by tsetse flies (Vale, 1974). By reducing their voltage output and grid spacing to allow for smaller and more delicate insects, they have since been used to determine mosquito flight direction in the field (Gillies et al., 1978), although their original design is still about as efficient for catching mosquitoes (~ 42%, Knols et al., 1998) as it is for catching tsetse (~ 45%, Packer & Brady, 1990). The original tsetse design has been used to great effect alongside OBETs to unpick subtle differences in the host-seeking behaviour of *An. arabiensis* and *An. quadriannulatus* with respect to odour source and entry response (Torr et al., 2008). Their use in the current study to aid in the interpretation of mosquito flight behaviour around test and control sticky traps highlights their value as an unbiased tool with which to scrutinize mosquito behaviour and evaluate monitoring and trapping devices. Electric nets, however, still represent an under-used tool for quantifying mosquito behaviour in the field.

### *Conclusions*

The results presented here support the development of trapping tools whose designs are based on specific and quantified behaviours of target organisms. Seven nights of data collection during only one season is only sufficient to provide an indication that sticky traps and visual cues warrant further study to determine their effectiveness at sampling outdoor host-seeking *An. gambiae* s.l. Their practical advantages and low cost make them an attractive alternative to other sampling techniques and the incorporation of additional design features based on quantified host-seeking behaviour could increase their efficiency and overall collection rate. It seems unlikely that HLCs can be improved on, given that all host-seeking *An. gambiae* are finely tuned to successfully locate human hosts. Some of the greater catch found in HLC may be explained by their position within a village compound where host-associated cues are likely to be abundant. Nonetheless, new tools, calibrated against local HLCs, are needed which allow us to infer biting rate from

number of mosquitoes caught; sticky traps offer potential as alternatives to HLCs.

Furthermore, reports of multiple insecticide resistance across sub-Saharan Africa (Betson et al., 2009; Edi et al., 2012), including at the study site (Kwiatkowska et al., 2013), highlight the need for control techniques that are not solely reliant on WHO approved insecticides to complement existing intradomicilliary insecticidal interventions (Govella & Ferguson, 2012). Catching devices, fully optimised by incorporating quantified behavioural responses, may be sufficiently effective to remove substantial numbers of mosquitoes from specific epidemiological and ecological contexts and have the added advantage of working outdoors, where it can be difficult to use insecticides in a targeted way (Ferguson et al., 2010). There is a compelling need, then, for behavioural studies to fully expound host-seeking behaviour in mosquito disease vectors, and close range landing in particular.

## 8 GENERAL DISCUSSION

This research set out to examine some of the steps in the sequence of behaviours that take mated female mosquitoes from their resting sites, through odour plumes to potential hosts. By systematically presenting some of the stimuli implicated in host-seeking behaviour, it has been possible to identify specific behavioural responses to these stimuli. This has led to the development of assays that allow multiple stimuli to be presented simultaneously and for integrated behavioural responses to be quantified. In particular, it has been demonstrated that olfactory stimuli modulate the responses of *An. gambiae* to visual cues and other, as yet unidentified, sensory systems appear to be involved in flight control around physical obstacles. Moreover, laboratory results have been used to design a simple, visually conspicuous mosquito trap that is capable of operating outdoors. This trap collected more than twice the number of *An. gambiae* than an identical, but non-visually conspicuous trap. The successful application of results from behavioural studies in the laboratory to the immediate problem of monitoring outdoor biting malaria vectors validates the coupling of behavioural research to the practical control of mosquito vectors.

### 8.1 Activation of host-seeking

A circadian rhythm of activity places *An. gambiae* in a crepuscular/nocturnal niche. Endogenous factors, including insemination (Jones & Gubbins, 1978) and parity (Bockarie et al., 1996), influence the timing of circadian activity in mosquitoes. However, the potential effect of exogenous stimuli, particularly those arising from hosts, on activity levels has never been considered. Growing evidence of temporal plasticity in biting behaviour within wild populations of *An. gambiae s.l.* (Reddy et al., 2011; Russell et al., 2011; Yohannes & Boelee, 2012) highlights the importance of understanding when host-seeking activity is triggered, and how.

The research presented in Chapter 4 tests how the circadian activity of mated female *An. gambiae* might be modified by exposure to air-borne host-associated olfactory stimuli. In a stream of clean air, activity in *An. gambiae* is observed at three points across the night and broadly corresponds to activity patterns previously reported in assays that also use clean air conditions (Jones & Gubbins, 1978). Presumably, stochastic activity functions 1: to bring mosquitoes out from their day-time refugia into the open, where they may encounter wind-borne olfactory signals from a host, and 2: to periodically induce take off into air streams, from which mosquitoes may then enter odour plumes. Based on this, and other studies (Jones & Gubbins, 1978), this activity appears to occur across much of the night, during which time some mosquitoes will encounter the entire suite of sensory stimuli needed to complete the behavioural sequence that results in a successful blood meal.

Adding human volatiles and a continuous plume of carbon dioxide to the air flow increases mosquito activity in hour 3 of the subjective night, but not in hours 6 or 10. Mated females thus seem primed to respond immediately to olfactory cues from potential hosts when these cues are detected earlier in the night. Such a mechanism may have the advantage of immediately inducing flight into an already-detected odour plume, rather than waiting until later in the night before spontaneously ranging flight occurs, the later presumably resulting in greater energy expenditure.

As they only offer protection during the hours of sleep, bed nets represent a widely used and temporally phased intervention; their ability to reduce exposure to infective bites could be drastically undermined by earlier biting activity in the *An. gambiae* complex (Gatton et al., 2013). Vector control techniques that are temporally phased must consider their continuing efficacy in the face of this largely un-quantified dynamic.

As a first step in exploring the physiological mechanisms by which selective pressure from inter-domiciliary interventions may lead to early and/or outdoor

feeding behaviour, this study raises many questions about the initial stages of host-seeking, including what causes emergence from refugia and how activation is shaped by possible changes in sensitivity to host stimuli. It is feasible, although empirically untested, that early activation by olfactory stimuli may more frequently bring mosquitoes into contact with hosts whilst they are outdoors, before they retire to bed; exophagic phenotypes may then benefit from the adaptive advantage of completely avoiding inter-domiciliary interventions.

Research is needed to describe more thoroughly the behavioural periodicity presented here, including determining whether responsiveness to odour cues represents a truly circadian process (i.e. whether the pattern remains in total darkness) and if the activity observed in the present study is actually expressed as increased incidences of ranging free-flight behaviour. Some genes related to olfaction in *An. gambiae* are shown to be under circadian control (Rund et al., 2011) and the precise expression of this control could prove a worthy topic of further study. Assuming there is a heritable basis for this behavioural trait, it would be most interesting to conduct semi-field trials with mosquito strains selected for early and late biting behaviour to determine whether they also show differences in exophagy and endophagy.

## **8.2 Host-seeking flight**

Once activated, the next step in host-seeking behaviour entails detecting and responding to a plume of host-associated olfactory stimuli. Once a mosquito begins host-seeking flight, it is thought to range in a pattern that maximises its chances of encountering a plume of host-associated odour and, upon entering the plume, to orientate upwind through the plume to the source of odour. This broad description of olfactory-guided upwind anemotaxis is applied to the host-seeking behaviour of most hematophagous Diptera (Gibson & Torr, 1999) and the resource and/or mate-seeking behaviour of other insects that rely on odour plumes for resource location (Vickers, 2000).

Recent studies have begun to quantify the three-dimensional flight of *Cx. quinquefasciatus* (Lacey & Cardé, 2011) and *Ae. aegypti* (Dekker & Cardé, 2011), with a focus on their moment-to-moment responses to entering and exiting fine odour plume structures. The present study sought to observe similar behaviour on a spatial scale that *An. gambiae* might be expected to encounter in a field environment. This approach is intended to serve as an intermediary step for assaying whole behaviours in the laboratory, before the expense of testing laboratory findings in the field.

Rather than ranging being a flight behaviour entirely distinct from plume-following, a number of flight strategies were observed in both clean air and host-odour laden air streams, including smooth fast flights with little change in direction, slower tortuous flights and vertical dipping flight that brings mosquitoes close to the ground. These three types of flight also occurred in up, down and crosswind directions. Thus, *An. gambiae* appear to utilise a variety of orientation mechanisms that can be called upon to explore and exploit their environment. Such a propensity for behavioural heterogeneity increases an organism's resilience (Gomez-Marin et al., 2010) and is perhaps a factor contributing to the adaptive plasticity observed in wild phenotypes of *An. gambiae* s.l. (Ghalambor et al., 2007; Lefèvre et al., 2009). The success of vector control interventions diminishes as diversity in the vectorial system increases (Coluzzi, 1984), so an appreciation of the range of strategies found in host-seeking *An. gambiae* is vital to designing control programmes that target all modes by which mosquitoes may come into contact with hosts.

The stereotyped dipping behaviour, composed of a series of vertical oscillations close to, but not touching, the ground indicate a particularly novel form of behavioural flexibility. It is hypothesised here that *An. gambiae* may not be entirely reliant on continuous sampling of visual feedback to execute upwind anemotaxis and that inputs derived from this repeated dipping behaviour may be sufficient to enable guided navigation in situations where visual cues are insufficient or absent. Exploitable inputs could come from the



apparent expansion and contraction of ground patterns as mosquitoes ascend and descend through dips. Alternatively, an unknown mechanosensory mechanism could be at work through which mosquitoes might detect distortions in the flow of air around their bodies. Two different sets of neurons in the Johnston's organ of *Drosophila* are capable of differentiating between flowing air, produced by wind, and oscillating air movement, caused by sound (Yorozu et al., 2009). Should similar neurons exist in mosquitoes, they may enable them to determine their ground speed and direction with respect to the wind as they move through the atmospheric boundary layer (Gillett, 1979), or alternatively to determine their proximity to the ground through detection of reflected sound. An additional adaptive advantage of this energy-intensive dipping behaviour may be that individuals can better control their flight in the lower wind speeds found closer to the ground.

That such a distinctive and consistent behaviour has not previously been reported in *An. gambiae* raises the prospect that other important behavioural characteristics are also unknown, having possibly remained hidden by the difficulties of observing species' nocturnal activity due to low light levels, and the relatively small arenas that have been used to observe mosquito flight in the laboratory. More research to quantify the free-flight behaviour of *An. gambiae* is called for to ensure that our understanding of how this organism navigates in its environment is as comprehensive as possible. This should include experiments designed to determine the constraints of navigation in *An. gambiae*, including the effect of size, shape, position and contrast of visual stimuli on navigation and whether orientation is different, or even possible, in the absence of light and moving air.

Mosquitoes demonstrated a surprising and striking fixation around the black floor markers placed inside the arena to provide visual feedback for optomotor-guided anemotaxis. However, this response only occurs in mosquitoes exposed to a plume of whole human odour and is entirely absent in clean air assays. Although not devised to test the interaction between

vision and olfaction, the prominence of this apparent interaction warranted further study, and formed the basis of the subsequent experiment.

### **8.3 The role of visual cues in host-seeking**

In comparison to our understanding of long range (metres) olfactory responses, comparatively little is known about the way mosquitoes hone in on hosts at close (< 1 m) range (Gibson & Torr, 1999). Convection currents associated with the warm body of a host are often implicated in close range host location (Eiras & Jepson, 1994; Takken et al., 1997b), although they remain understudied. Furthermore, efforts to understand the ecological importance of vision in the mosquito life-cycle have focussed heavily on elucidating its role in orientation, with some attention paid to finding oviposition and resting sites, mating swarm markers and, most infrequently of all, hosts (Allan et al., 1987; Gibson & Torr, 1999). This is particularly true for nocturnal mosquito species and is an unfortunate oversight, as initial field work in this area provides promising evidence that visual cues do indeed play a role in host-seeking behaviour, even in low light levels (Hauffe, 1964; Bidlingmeyer & Hem, 1980; Gillies & Wilkes, 1982; Bidlingmeyer, 1994). Recent advances in video and computing technology have opened the possibility of tracking small, nocturnal insects on the wing and this technology has been employed to begin to fill the gaps in our understanding of vision in host-seeking.

*Anopheles gambiae* demonstrate a number of remarkable responses not only to visually conspicuous (black) targets, but also to targets made from clear Perspex. Moreover, these responses vary according to the presence or absence of host-associated olfactory stimuli. When such olfactory stimuli are absent, mosquitoes do not tend to approach either target. Expanding visual stimuli are indicative of potential collision (Egelhaaf & Kern, 2002); as the black target is the most prominent vertical visual cue at the upwind end of the arena, individuals are likely to execute flight patterns around this object that limit its rapid expansion in their field of view and by so doing, avoid collisions with it. How mosquitoes are also able to avoid the clear target at distance is

a feat that cannot readily be explained by these data. However, their response to the clear target in plumes of host odour hints at possible explanations (see following discussion).

Olfactory signals from human hosts mediate a change in the response of *An. gambiae* to both black and clear targets. Rather than avoiding them, individuals approach targets closely, i.e.  $\leq 15$  cm, before turning away sharply. Around black targets, this behaviour is characterised by a sudden decrease in speed and concomitant increase in angular velocity, followed by a brief surge in the speed of vertical displacement as the insect flies up and away, before returning to normal flight. A similar pattern is observed in approaches towards clear targets, although these happen much less frequently than approaches to black targets and tend not to involve vertical displacement after turning; mosquitoes also tend to turn away from clear targets later (i.e. when they are closer to the clear target). Mosquitoes never land on either target, regardless of odour treatment.

The implications of these findings are three-fold. Firstly, these data provide the first empirical evidence of an olfactory-mediated change in responsiveness to visual stimuli in host-seeking mosquitoes. Olfactory cues apparently override the otherwise aversive visual expansion of the black target; this seems a necessary alteration to behaviour if females are to ever approach a potential host. Secondly, the physical properties of the clear target also induce a similar behavioural alteration, albeit less frequently and slightly different in expression of the turn component, implying that mosquitoes may be able to determine that the object is present by non-visual means. Perhaps mechano-sensory reception, as implicated in the earlier discussion regarding ground detection, is involved in interpreting changes in the flow of air around a vertical object. Such mechanisms should be investigated experimentally and the possibility that some visual cues may emanate from the clear target should be ruled out. Finally, the failure of mosquitoes to alight on the targets suggests that landing may be triggered by different stimuli to those presented, such as heat, which is a strong landing

cue for some species (Eiras & Jepson, 1994; Takken et al., 1997); the absence of such close range cues may be what triggered a 'last ditch' switch from landing to 'escape' response.

The olfactory-enhanced attraction of mosquitoes to the conspicuous black target and, to a lesser extent, the clear target, represents an important addition to our understanding of host-seeking behaviour. Furthermore, visual cues have the potential to be incorporated into trap design to increase their attraction to host-seeking mosquitoes. These ideas are taken forward in subsequent field evaluations of a new trap to exploit the interaction between olfaction and vision in mosquito host-seeking behaviour.

#### **8.4 Prototype trap design based on laboratory findings**

The threat of behavioural and physiological resistance of *An. gambiae* to widely-used intra-domiciliary interventions, such as indoor residual spraying and insecticide treated bed nets, is creating a pressing need for outdoor tools to both monitor and control the population (Govella & Ferguson, 2012). For innovations in these areas to succeed, it is important that design and implementation choices are based on a sound and unbiased understanding of the disease vectors' ecology and how this is being disrupted or exploited (Torr, 1994). To this end, the attractive response to visual stimuli identified in the previous experiment forms the basis for a prototype outdoor trap, tested in Burkina Faso, West Africa.

A simple odour-baited trap made from a transparent sticky film was found to catch more *An. gambiae* when it was visually conspicuous than when it was transparent. Adjacent electric nets indicate that both clear and black sticky traps are equally efficient, so the greater number of mosquitoes caught on the black trap seems to be the result of greater overall attraction to the trap, rather than increased landing behaviour. These field results correspond well with the laboratory finding that host-seeking *An. gambiae* do not alight on visually conspicuous targets in host odour, although they do closely

approach them, whilst closely approaching clear targets also occurred, although less frequently, as is seen in the smaller catch of clear sticky traps.

Now this response has been observed in colonies in the laboratory and in wild populations in the field, work to optimise the response to visual targets can begin. Features of visual targets, such as their shape, size, elevation and orientation have all been shown to determine the response of tsetse flies to baits and targets (Gibson & Torr, 1999) and these factors should all be tested in the field to determine their effect on mosquito responses, so characteristics to include in future, optimal trap designs can be identified. Including visually conspicuous design elements in existing mosquito traps should also be considered as a means by which to increase the number of host-seeking individuals attracted to their vicinity, although it should be noted that this may not necessarily increase trap catch if this is dependent on landing or entry behaviours that might not be initiated successfully.

From a procedural perspective, these promising field results also highlight the value of laboratory studies that allow insects to express behaviour in a naturalistic, but controlled, environment. It is possible that assays with simplistic measures of 'attraction', such as counting the number of individuals landing on an attractant odour source, may miss important behaviours that precede or follow the point at which the measure of attraction is taken (Kennedy, 1978); the increase in attraction of host-seeking mosquitoes to the black trap and the black target may have been misinterpreted if electric nets and video technology, respectively, had not been employed to shed light on the nature of mosquito approaches to these objects.

## **8.5 Future research areas**

As laid out in this discussion, there are a number of areas that merit concerted research attention to improve our understanding of fundamental Culicid biology, with a view to identifying exploitable traits. This is particularly pressing given recent reports of waning efficacy of established mosquito

control techniques in some regions of Africa, proposed to be a consequence of behavioural and physiological adaptation by disease vectors to these techniques. The most urgent research areas include, but are not limited to:

- Determining whether mosquitoes are capable of surface detection and, if so, ascertaining the sensory and neural mechanisms by which this takes place. How such sensory reception shapes interactions with physical stimuli and variability in air flow should also be considered. Beyond contributing to a fuller understanding of insect sensory physiology, findings may be of particular relevance to the continued use of counter-flow and suction traps (such as the Centre for Disease Control light trap and the Mosquito Magnet), as their trapping efficiency is determined, in part, by the suction strength and the proximity within which mosquitoes approach the trap (Cooperband & Cardé, 2006).
- Continuing laboratory and field studies exploring the interaction between olfactory and visual systems. Such experiments may consider the effect of different odour compounds on attraction and the effect of changing the visual properties of target or trap characteristics, such as size, orientation and colour. Traps that exploit the full range of cues used in host location are likely to be most efficient; optimised trap designs are predicated on acquiring a more complete understanding of host-seeking behaviour from assays that sensitively discriminate between the different behavioural responses to specific stimuli and combinations of stimuli.
- Identifying and quantifying the cues involved in landing, including the range of spatial scales over which they may operate. These should be experimentally uncoupled from host-seeking and plume-following behaviour. Once they have been established, it would be most useful to identify material characteristics that maximise the length of time mosquitoes spend on the material's surface, because this could increase the length of their contact time with insecticide-treated surfaces, such as durable wall linings (Messenger et al., 2012).

- Developing new monitoring and control techniques that are specifically designed to work outdoors and that make use of quantified behaviours. Efforts to evaluate these techniques using appropriate tools should continue.
- Extending similar laboratory and field-based methods to the study of oviposition behaviour in mosquitoes. Efficacy of control techniques, such as auto-dissemination of larval biocides (Caputo et al., 2012), might be improved by a better understanding of the precise nature of oviposition behaviour, including establishing whether ovipositing mosquitoes contact the water's surface during egg-laying, and if so, for how long.

Similar principles could also be applied to insect conservation efforts, where a detailed understanding of behavioural ecology could provide insights that may aid in the design of successful conservation management strategies and also lead to better monitoring tools. In a conservation context, monitoring tools that are both capable of operating in low density populations and do not kill samples would be particularly advantageous.

## **8.6 Conclusions**

The research presented here has shed light on some facets of host-seeking behaviour in the main African malaria vector, *An. gambiae*. The experimental results add to our knowledge of this complex sequence of behaviours and also highlight deficiencies in our present understanding of elements of stimulus-response behaviour in this species and, perhaps, other insects systems too. These findings can be used to feed into improvements in the efficacy of the tools available for monitoring and control of this disease vector. The paradigm of systematic physiological, behavioural and ecological experimentation, similar to that used so effectively to control tsetse flies, should feature even more prominently in medical and veterinary entomology research.

## 9 REFERENCES

- Allan, S.A., Day, J.F. and Edman, J.D. (1987) Visual ecology of biting flies. *Annual Review of Entomology*, **32**, 297-316.
- Ansell, J., Hamilton, K.A., Pinder, M., Walraven, G.E.L. and Lindsay, S.W. (2002) Short-range attractiveness of pregnant women to *Anopheles gambiae*. *Transactions of the Royal Society of Tropical Medicine and Hygiene*, **96**, 113-116.
- Atema, J. (1996) Eddy chemotaxis and odor landscapes: Exploration of nature with animal sensors. *Biological Bulletin*, **191**, 129-138.
- Athrey, G., Hodges, T.K., Reddy, M.R., Overgaard, H.J., Matias, A., Ridl, F.C., Kleinschmidt, I., Caccone, A. and Slotman, M.A. (2012) The effective population size of malaria mosquitoes: large impact of vector control. *PLoS Genetics*, **8**(12).
- Atkins, M.D. (1980) *Introduction to Insect Behaviour*. New York, MacMillan Publishing Limited.
- Baird, E., Kreiss, E., Wcislo, W., Warrant, E. and Dacke, M. (2011) Nocturnal insects use optic flow for flight control. *Biology Letters*, **7**, 499-501.
- Baker, T.C. (1990) Upwind flight and casting flight: complementary phasic tonic systems used for location of sex pheromone sources by male moths. In K.B. Døving (Ed.) (1990) *Proceedings of the X International Symposium on Olfaction and Taste*, pp. 18-25. Oslo, Graphic Communication Systems.



- Baldet, T., Diabaté, A. and Guiguemdé, T.R. (2003) Malaria transmission in 1999 in the rice field area of the Kou Valley (Bama), (Burkina Faso). *Sante*, **13**, 55-60.
- Barrozo, R.B., Minoli, S.A. and Lazzari, C.R. (2004a) Circadian rhythm of behavioural responsiveness to carbon dioxide in the blood-sucking bug *Triatoma infestans* (Heteroptera: Reduviidae). *Journal of Insect Physiology*, **50**, 249-254.
- Barrozo, R.B., Schilman, P.E., Minoli, S.A. and Lazzari, C.R. (2004b) Daily rhythms in disease-vector insects. *Biological Rhythm Research*, **35**, 79-92.
- Beeuwkes, J., Spitzen, J., Spoor, C.W., van Leeuwen, J.L. and Takken, W. (2008) 3-D flight behaviour of the malaria mosquito *Anopheles gambiae* s.s. inside an odour plume. *Proceedings of the Netherlands Entomological Society Meeting*, **19**, 137-146.
- Benedict, M. (Ed.) (2008) *Methods in Anopheles Research Version 4*. Available from <http://www.mr4.org/Publications/MethodsInAnophelesResearch/tabid/336/Default.aspx>, accessed 12 May 2010.
- Bernays, E.A. and Singer, M.S. (1998) A rhythm underlying feeding behaviour in a highly polyphagous caterpillar. *Physiological Entomology*, **23**, 295-302.
- Besansky, N.J., Hill, C.A. and Costantini, C. (2004) No accounting for taste: host preference in malaria vectors. *TRENDS in Parasitology*, **20**, 249-251.

- Betson, M., Jawara, M. and Awolola, T.S. (2009) Status of insecticide susceptibility in *Anopheles gambiae* s.l. from malaria surveillance sites in The Gambia. *Malaria Journal*, **8**(187).
- Bidlingmeyer, W.L. (1975) Mosquito flight paths in relation to the environment: Effect of vertical and horizontal visual barriers. *Annals of the Entomological Society of America*, **68**, 51-57.
- Bidlingmeyer, W.L. (1994) How mosquitoes see traps: Role of visual responses. *Journal of the American Mosquito Control Association*, **10**, 272-279.
- Bidlingmeyer, W.L. and Hem, D.G. (1979) Mosquito (Diptera: Culicidae) flight behaviour near conspicuous objects. *Bulletin of Entomological Research*, **69**, 691-700.
- Bidlingmeyer, W.L. and Hem, D.G. (1980) The range of visual attraction and the effect of competitive visual attractants upon mosquito (Diptera: Culicidae) flight. *Bulletin of Entomological Research*, **70**, 321-342.
- Bockarie, M.J., Alexander, N., Bockarie, F., Ibam, E., Barnish, G. and Alpers, M. (1996) The late biting habit of parous *Anopheles* mosquitoes and pre-bedtime exposure of humans to infective female mosquitoes. *Transactions of the Royal Society of Tropical Medicine and Hygiene*, **90**, 23-25.
- Bowen, M.F. (1992) Lack of correlation between peripheral receptor sensitivity and the daily pattern of host-seeking behavior in female *Culex pipiens* mosquitoes. *Bulletin of the Society of Vector Ecology*, **17**, 20-24.

- Brady, J. (1975) Circadian changes in central excitability – the origin of behavioural rhythms in tsetse flies and other animals? *Journal of Entomology Series A: General Entomology*, **50**, 79-95.
- Brady, J. (1987) The sunset activity of tsetse flies: a light threshold study on *Glossina morsitans*. *Physiological Entomology*, **12**, 363-372.
- Brady, J. and Crump, A.J. (1978) The control of circadian flight activity rhythms in tsetse flies: environment or physiological clock? *Physiological Entomology*, **3**, 177-190.
- Brady, J., Gibson, G. and Packer, M.J. (1989) Odour movement, wind direction, and the problem of host-finding by tsetse flies. *Physiological Entomology*, **14**, 369-38.
- Braks, M.A.H., Meijerink, J. and Takken, W. (2001) The response of the malaria mosquito, *Anopheles gambiae*, to two components of human sweat, ammonia and L-lactic acid, in an olfactometer. *Physiological Entomology*, **26**, 142-148.
- Browne, S.M. and Bennett, G.F. (1981) Response of mosquitoes (Diptera: Culicidae) to visual stimuli. *Journal of Medical Entomology*, **18**(6), 505-521.
- Budick, S.A., Reiser, M.B. and Dickinson, M.H. (2007) The role of visual and mechanosensory cues in structuring forward flight in *Drosophila melanogaster*. *Journal of Experimental Biology*, **210**, 4092-4103.
- Caputo, B., Ienco, A., Cianci, D., Pombi, M., Petrarca, V., Baseggio, A., Devine, G.J. and della Torre, A. (2012) The “auto-dissemination” approach: A novel concept to fight *Aedes albopictus* in urban areas. *PLoS Neglected Tropical Diseases*, **6**(8).

- Cardé, R.T. (1996) Odour plumes and odour-mediated flight in insects. In Bock, G.R. and Cardew, G. (Eds.) (1996) *Ciba Foundation Symposium 200 – Olfaction in Mosquito-Host Interactions*. Wiley, pp. 54-70.
- Cardé, R.T. (2009) Orientation. In Resh, V.H. and Cardé, R.T. (Eds.) (2009) *Encyclopaedia of Insects, Second Edition*. San Diego, Academic Press, pp. 729-732.
- Cardé, R.T., Cardé, A.M. and Girling, R.D. (2012) Observations on the flight paths of day-flying moth *Virbia lamae* during periods of mate location: do males have a strategy for contacting the pheromone plume? *Journal of Animal Ecology*, **81**, 268-276.
- Cardé, R.T. and Gibson, G. (2010) Host finding by female mosquitoes: Mechanisms of orientation to host odours and other cues. In Takken, W. and Knols, B.J.G. (2010) *Olfaction in Vector-Host Interactions (Ecology and Control of Vector-Borne Diseases Volume 2)*. Wageningen, The Netherlands, Wageningen Academic Publishers, pp. 115-142.
- Cardé, R.T. and Willis, M.A. (2008) Navigational strategies used by insects to find distant, wind-borne sources of odor. *Journal of Chemical Ecology*, **34**, 854-866.
- Centre for Disease Control (CDC) (2007) Infectious disease information: Mosquito-borne diseases. Available from [http://www.cdc.gov/ncidod/diseases/list\\_mosquitoborne.htm](http://www.cdc.gov/ncidod/diseases/list_mosquitoborne.htm), accessed 9 March 2011.
- Charlwood, J.D., Paru, R., Dagoro, H. and Lagog, M. (1986) Influence of moonlight and gonotrophic age on biting activity of *Anopheles farauti*

(Diptera: Culicidae) from Papua New Guinea. *Journal of Medical Entomology*, **23**, 132-135.

Charlwood, J.D., Pinto, J., Sousa, C.A., Masden, H., Ferreira, C. and do Rosario, V.E. (2002) The swarming and mating behaviour of *Anopheles gambiae* s.s. (Diptera: Culicidae) from São Tomé Island. *Journal of Vector Ecology*, **27**, 178-183.

Chow, D.M., Theobald, J.C. and Frye, M.A. (2011) An olfactory circuit increases the fidelity of visual behaviour. *Journal of Neuroscience*, **31**, 15035-15047.

Clements, A.N. (1992) *The Biology of Mosquitoes Volume 1: Development, Nutrition, Reproduction*. London, Chapman and Hall.

Clements, A.N. (1999) *The Biology of Mosquitoes Volume 2: Sensory Reception and Behaviour*. London, Chapman and Hall.

Coetzee, M., Hunt, R.H., Wilkerson, R., Della Torre, A., Coulibaly, M.B. and Besansky, N.J. (2013) *Anopheles coluzzii* and *Anopheles amharicus*, new members of the *Anopheles gambiae* complex. *Zootaxa*, **3619**, 246-274.

Coluzzi, M. (1984) Heterogeneities of the malaria vectorial system in tropical Africa and their significance in malaria epidemiology and control. *Bulletin of the World Health Organization*, **62**, 407-413.

Colvin, J., Brady, J. and Gibson, G. (1989) Visually-guided, upwind turning behaviour of free-flying tsetse flies in odour-laden wind: a wind-tunnel study. *Physiological Entomology*, **14**, 31-39.

- Cooperband, M.F. and Cardé, R.T. (2006) Orientation of *Culex* mosquitoes to carbon dioxide-baited traps: flight manoeuvres and trapping efficiency. *Medical and Veterinary Entomology*, **20**, 11-26.
- Cork, A. and Park, K.C. (1996) Identification of electrophysiologically-active compounds for the malaria mosquito, *Anopheles gambiae*, in human sweat extracts. *Medical and Veterinary Entomology*, **10**, 269-276.
- Costantini, C., Gibson, G., Brady, J., Merzagora, L. and Coluzzi, M. (1993) A new odour-baited trap to collect host-seeking mosquitoes. *Parassitologia*, **35**, 5-9.
- Costantini, C., Gibson, G., Sagnon, N., Della Torre, A., Brady, J. and Coluzzi, M. (1996) Mosquito responses to carbon dioxide in a West African Sudan savanna village. *Medical and Veterinary Entomology*, **10**, 220-227.
- Costantini, C., Sagnon, N., Della Torre, A., Diallo, M., Brady, J., Gibson, G. and Coluzzi, M. (1998a) Odor-mediated host preferences of West African mosquitoes, with particular reference to malaria vectors. *American Journal of Tropical Medicine and Hygiene*, **58**, 56-63.
- Costantini, C., Sagnon, N.F., Sanogo, E., Merzagora, L. and Coluzzi, M. (1998b) Relationship to human biting collections and influence of light and bednet in CDC light-trap catches of West African malaria vectors. *Bulletin of Entomological Research*, **88**, 503-511.
- Cummins, B., Cortez, R., Foppa, I., Walbeck, J. and Hyman, J.M. (2012) A spatial model of mosquito host-seeking behaviour. *PLoS Computational Biology*, **8**(5).

- Curtis, C.F. (1996) *Introduction I: an overview of mosquito biology, behaviour and importance*. In Ciba Foundation (1996) *Olfaction in Mosquito-Host Interactions*. Chichester, John Wiley & Sons, pp. 3-7.
- Dabiré, K.R., Diabaté, A., Namountougou, M., Djogbenou, L., Wondji, C., Chandre, F., Simard, F., Ouédraogo, J-B., Martin, T., Weill, M. and Baldet, T. (2012) Trends in insecticide resistance in natural populations of malaria vectors in Burkina Faso, West Africa: 10 years' surveys. In Perveen, F. (Ed.) *Insecticides – Pest Engineering* (2012), Chapter 22, pp. 479-502.
- David, C.T. (1982) Compensation for height in the control of groundspeed by *Drosophila* in a new, 'barber's pole' wind tunnel. *Journal of Comparative Physiology*, **147**, 485-493.
- David, C.T. (1986) Mechanisms of directional flight in wind. In Payne, T.L., Birch, M.C. and Kennedy, C.E.J. (1986) *Mechanisms in Insect Olfaction*. Oxford, Oxford University Press, pp. 49-57.
- Daykin, P.N. and Kellogg, F.E. (1965) A two-air-stream observation chamber for studying responses of flying insects. *The Canadian Entomologist*, **97**, 264-268.
- Daykin, P.N., Kellogg, F.E. and Wright, R.H. (1965) Host-finding and repulsion of *Aedes aegypti*. *The Canadian Entomologist*, **97**, 239-263.
- De Jong, R. and Knols, B.G.J. (1995) Selection of biting sites on man by two malaria mosquito species. *Experientia*, **51**, 80-84.
- Dekker, T. and Cardé, R.T. (2011) Moment-to-moment flight manoeuvres of the female yellow fever mosquito (*Aedes aegypti* L.) in response to

plumes of carbon dioxide and human skin odour. *Journal of Experimental Biology*, **214**, 3480-3494.

Dekker, T. and Takken, W. (1998) Responses of *Anopheles arabiensis* Patton and *Anopheles quadriannulatus* Theobald to carbon dioxide, a man and a calf. *Medical and Veterinary Entomology*, **12**, 136-140.

Dekker, T., Geier, M. and Cardé, R.T. (2005) Carbon dioxide instantly sensitizes female yellow fever mosquitoes to human skin odours. *Journal of Experimental Biology*, **208**, 2963-2972.

Dekker, T., Takken, W. and Cardé, R.T. (2001) Structure of host-odour plumes influences catch of *Anopheles gambiae* s.s. and *Aedes aegypti* in a dual-choice olfactometer. *Physiological Entomology*, **26**, 124-134.

Dekker, T., Takken, W., Knols, B.G.J., Bouman, E., van de Laak, S., de Bever, A. and Huisman, P.W.T. (1998) Selection of biting sites on a human host by *Anopheles gambiae* s.s., *An. arabiensis* and *An. quadriannulatus*. *Entomologia Experimentalis et Applicata*, **87**, 295-300.

Denny, M.W. (1993) *Air and Water: The Biology and Physics of Life's Media*. Princeton, Princeton University Press.

Dugassa, S., Lindh, J.M., Torr, S.J., Oyieke, F., Lindsay, S.W. and Fillinger, U. (2012) Electric nets and sticky materials for analysing oviposition behaviour of gravid malaria vectors. *Malaria Journal*, **11**(374).

Duistermars, B.J. and Frye, M.A. (2010) Multisensory integration for odor-tracking by flying *Drosophila*: behavior, circuits and speculation. *Communicative & Integrative Biology*, **3**, 60-63.



- Dusenberry, D.B. (1990) Upwind searching for an odor plume is sometimes optimal. *Journal of Chemical Ecology*, **16**, 1971-1976.
- Edi, C.V.A., Koudou, B.G., Jones, C.M., Weetman, D. and Ranson, H. (2012) Multiple-insecticide resistance in *Anopheles gambiae* mosquitoes, southern Côte d'Ivoire. *Emerging Infectious Diseases*, **18**, 1508-1511.
- Egelhaaf, M. and Kern, R. (2002) Vision in flying insects. *Current Opinion in Neurobiology*, **12**, 699-706.
- Eiras, A.E. and Jepson, P.C. (1991) Host location by *Aedes aegypti* (Diptera: Culicidae): a wind tunnel study of chemical cues. *Bulletin of Entomological Research*, **81**, 151-160.
- Eiras, A.E. and Jepson, P.C. (1994) Responses of female *Aedes aegypti* (Diptera: Culicidae) to host odours and convection currents using an olfactometer bioassay. *Bulletin of Entomological Reserach*, **84**, 207-211.
- Elkington, J.S., Schal, C., Ono, T. and Cardé, R.T. (1987) Pheromone puff trajectory and upwind flight of male gypsy moths in a forest. *Physiological Entomology*, **12**, 399-406
- Facchinelli, L., Koenraadt, C.J.M., Fanello, C., Kijchalao, U., Valerio, L., Jones, J.W., Scott, T.W. and Della Torre, A. (2008) Evaluation of a sticky trap for collecting *Aedes* (Stegomyia) adults in a dengue-endemic area in Thailand. *American Journal of Tropical Medicine and Hygiene*, **78**, 904-909.
- Facchinelli, L., Valerio, L., Pombi, M., Reiter, P., Costantini, C. and Della Torre, A. (2007) Development of a novel sticky trap for container-breeding mosquitoes and evaluation of its sampling properties to

monitor urban populations of *Aedes albopictus*. *Medical and Veterinary Entomology*, **21**, 183-195.

Fairhurst, R.M., Nayyar, G.M.L., Breman, J.G., Hallett, R., Vennerstrom, J.L., Duong, S., Ringwald, P., Wellems, T.E., Plowe, C.V. and Dondrop, A.M. (2012) Meeting report – Artemisinin-resistant malaria: research challenges, opportunities, and public health implications. *American Journal of Tropical Medicine and Hygiene*, **87**, 231-241.

Favia, G., Lanfrancotti, A., Spanos, L., Siden-Kiamos, I. and Louis, C. (2001) Molecular characterization of ribosomal DNA polymorphisms discriminating among chromosomal forms of *Anopheles gambiae* ss. *Insect Molecular Biology*, **10**, 19-23.

Ferguson, H.M., Dornhaus, A., Beeche, A., Borgemeister, C., Gottlieb, M., Mulla, M.S., Gimnig, J.E., Fish, D. and Killeen, G.F. (2010) Ecology: a prerequisite for malaria elimination and eradication. *PLoS Medicine*, **7**(8).

Fry, S.N., Bichsel, M., Müller, P. and Robert, D. (2000) Tracking of flying insects using pan-tilt cameras. *Journal of Neuroscience Methods*, **101**, 59-67.

Frye, M.A., Tarsitano, M. and Dickinson, M.H. (2003) Odor localization requires visual feedback during free flight in *Drosophila melanogaster*. *Journal of Experimental Biology*, **206**, 843-855.

Gatton, M.L., Chitnis, N., Churcher, T., Donnelly, M.J., Ghani, A.C., Godfray, H.C.J., Gould, F., Hastings, I., Marshall, J., Ranson, H., Rowland, M., Shaman, J. and Lindsay, S.W. (2013) The importance of mosquito behavioral adaptations to malaria control in Africa. *Evolution*, **67**, 1218-1230.

- Geier, M., Bosch, O.J. and Boeckh, J. (1999) Influence of odour plume structure on upwind flight of mosquitoes towards hosts. *The Journal of Experimental Biology*, **202**, 1639-1648.
- Ghalambor, C.K., McKay, J.K., Carroll, S.P. and Reznick, D.N. (2007) Adaptive versus non-adaptive phenotypic plasticity and the potential for contemporary adaptation in new environments. *Functional Ecology*, **21**, 394-407.
- Gibson, G. (1985) Swarming behaviour of the mosquito *Culex pipiens quinquefasciatus*: a quantitative analysis. *Physiological Entomology*, **10**, 283-296.
- Gibson, G. (1995) A behavioural test of the sensitivity of a nocturnal mosquito, *Anopheles gambiae*, to dim white, red and infra-red light. *Physiological Entomology*, **20**, 224-228.
- Gibson, G., Costantini, C., Sagnon, F., Della Torre, A. and Coluzzi, M. (1997) The response of *Anopheles gambiae*, and other mosquitoes in Burkina Faso, to CO<sub>2</sub> – the start of a search for synthetic human odour. *Annals of Tropical Medicine and Parasitology*, **91**, Supplement 1, S123-S124.
- Gibson, G. and Russell, I.J. (2006) Flying in tune: sexual recognition in mosquitoes. *Current Biology*, **16**, 1311-1316
- Gibson, G. and Torr, S.J. (1999) Visual and olfactory responses of haematophagous Diptera to host stimuli. *Medical and Veterinary Entomology*, **13**, 2-23.
- Gillett, J.D. (1979) Out for blood: flight orientation up-wind in the absence of visual cues. *Mosquito News*, **39**, 221-229.

- Gillies, M.T. (1969) The ramp-trap, an unbaited device for flight studies of mosquitoes. *Mosquito News*, **29**, 189-193.
- Gillies, M.T. (1980) The role of carbon dioxide in host-finding by mosquitoes (Diptera: Culicidae): A review. *Bulletin of Entomological Research*, **70**, 525-532.
- Gillies, M.T. and Coetzee, M. (1987) *A supplement to the Anophelinae of Africa south of the Sahara (Afro-tropical Region)*. Publications of the South African Institute for Medical Research, No. 55.
- Gillies, M.T. and de Meillon, B. (1968) *The Anophelinae of Africa south of the Sahara (Ethiopian Zoogeographical Region)*. Publications of the South African Institute for Medical Research, No. 54.
- Gillies, M.T., Jones, M.D.R. and Wilkes, T.J. (1978) Evaluation of a new technique for recording the direction of flight of mosquitoes (Diptera: Culicidae) in the field. *Bulletin of Entomological Research*, **68**, 145-152.
- Gillies, M.T. and Snow, W.F. (1967) A CO<sub>2</sub>-baited sticky trap for mosquitoes. *Transactions of the Royal Society of Tropical Medicine and Hygiene*, **61**, 20.
- Gillies, M.T. and Wilkes, T.J. (1974) Evidence for downwind flights by host-seeking mosquitoes. *Nature*, **252**, 388-389.
- Gillies, M.T. and Wilkes, T.J. (1982) Responses of host-seeking *Mansonia* and *Anopheles* mosquitoes (Diptera: Culicidae) in West Africa to visual features of a target. *Journal of Medical Entomology*, **19**, 68-71.

- Gimnig, J.E., Walker, E.D., Otieno, P., Kosgei, J., Olang, G., Ombok, M., Williamson, J., Marwanga, D., Abong'o, D., Desai, M., Kariuki, S., Hamel, M.J., Lobo, N.F., Vulule, J. and Bayoh, M.N. (2012) Incidence of malaria among mosquito collectors conducting human landing catches in Western Kenya. *American Journal of Tropical Medicine and Hygiene*, **88**, 301-308.
- Gimonneau, G., Bouyer, J., Morand, S., Besansky, N.J., Diabate, A. and Simard F. (2010) A behavioural mechanism underlying ecological divergence in the malaria mosquito *Anopheles gambiae*. *Behavioral Ecology*, **21**, 1087-1092.
- Gimonneau, G., Pombi, M., Dabiré, R.K., Diabaté, A., Morand, S. and Simard, F. (2012) Behavioural responses of *Anopheles gambiae* sensu stricto M and S molecular form larvae to an aquatic predator in Burkina Faso. *Parasites and Vectors*, **5**(65).
- Girling, R. and Cardé, R. (2007) Analysis and manipulation of the structure of odor plumes from a piezo-electric release system and measurements of upwind flight of male almond moths, *Cadra cautella*, to pheromone plumes, *Journal of Chemical Ecology*, **33**, 1927-1945.
- Githeko, A.K., Adungo, N.I., Karanja, D.M., Hawley, W.A, Vulule, J.M., Seroney, I.K., Ofulla, A.V.O., Atieli, F.K., Ondijo, S.O., Genga, I.O., Odada, P.K., Situbi, P.A. and Oloo, J.A. (1996) Some observations on the biting behaviour of *Anopheles gambiae* s.s., *Anopheles arabiensis*, and *Anopheles funestus* and their implications for malaria control. *Experimental Parasitology*, **82**, 306-315.
- Gomez-Marin, A., Duistermars, B.J., Frye, M.A. and Louis, M. (2010) Mechanisms of odor-tracking: multiple sensors for enhanced perception of behaviour. *Frontiers in Cellular Neuroscience*, **4**, 1-15.

- Govella, N.J., Chaki, P.P., Geissbuhler, Y., Kannady, K., Okumu, F., Charlwood, J.D., Anderson, R.A. and Killeen, G.F. (2009) A new tent trap for sampling exophagic and endophagic members of the *Anopheles gambiae* complex. *Malaria Journal*, **8**(157).
- Govella, N.J., Chaki, P.P., Mpangile, J.M. and Killeen, G.F. (2011) Monitoring mosquitoes in urban Dar es Salaam: Evaluation of resting boxes, window exit traps, CDC light traps, Ifakara tent traps and human landing catches. *Parasites and Vectors*, **4**(40).
- Govella, N.J. and Ferguson, H. (2012) Why use of interventions targeting outdoor biting mosquitoes will be necessary to achieve malaria elimination. *Frontiers in Physiology*, **3**(199).
- Green, C.H. and Flint, S. (1986) An analysis of colour effects in the performance of the F2 trap against *Glossina pallidipes* Austen and *G. morsitans morsitans* Westwood (Diptera: Glossinidae). *Bulletin of Entomological Research*, **76**, 409-418.
- Guerenstein, P.G. and Hildebrand, J.G. (2008) Roles and effects of environmental carbon dioxide in insect life. *Annual Review of Entomology*, **53**, 161-178.
- H.M. Nautical Almanac Office (2011) *Astronomical Almanac*. Available from <http://www.ukho.gov.uk/HMNAO/Pages/Home.aspx>, accessed November 2011.
- Hauffe, W.O. (1964) Visual attraction as a principle in design of mosquito traps. *The Canadian Entomologist*, Jan-Feb, 118.
- Hawkes, F., Young, S. and Gibson, G. (2012) Modification of spontaneous activity pattern in the malaria vector *Anopheles gambiae sensu stricto*

when presented with host-associated stimuli. *Physiological Entomology*, **37**, 233-240.

Healy, T.P. and Copland, M.J.W. (1995) Activation of *Anopheles gambiae* mosquitoes by carbon dioxide and human breath. *Medical and Veterinary Entomology*, **9**, 331-336.

Healy, T.P. and Copland, M.J.W. (2000) Human sweat and 2-oxopentatonic acid elicit a landing response from *Anopheles gambiae*. *Medical and Veterinary Entomology*, **14**, 195-200.

Hecht, O. and Hernandez-Corzo, J. (1963) On the visual orientation of mosquitoes in their search of resting places. *Entomologia Experimentalis et Applicata*, **6**, 63-74.

Hii, J.L.K., Smith, T., Mai, A., Ibam, E. and Alpers, M.P. (2000) Comparison between anopheline mosquitoes (Diptera: Culicidae) caught using different methods in a malaria endemic area of Papua New Guinea. *Bulletin of Entomological Research*, **90**, 211-219.

Huang, J. Walker, E.D., Vulule, J. and Miller, J.R. (2007) The influence of darkness and visual contrast on oviposition by *Anopheles gambiae* in moist and dry substrates. *Physiological Entomology*, **32**, 34-40.

Jackson, K.M. (1979) Fitting of mathematical functions to biomechanical data. *IEEE Transactions of Biomedical Engineering*, **26**, 122-124.

Jones, M.D.R., Cubbin, C.M. and Marsh, D. (1972) Light-on effects and the question of bimodality in the circadian flight activity of the mosquito *Anopheles gambiae*. *Journal of Experimental Biology*, **57**, 347-357.

- Jones, M.D.R. and Gubbins, S.J. (1978) Changes in the circadian flight activity of the mosquito *Anopheles gambiae* in relation to insemination, feeding and oviposition. *Physiological Entomology*, **3**, 213-220.
- Jones, M.D.R. and Gubbins, S.J. (1979) Modification of female flight-activity by a male accessory gland pheromone in the mosquito *Culex pipiens quinquefasciatus*. *Physiological Entomology*, **4**, 345-351.
- Jones, M.D.R., Gubbins, S.J. and Cubbin, C.M. (1974) Circadian flight activity in four sibling species of the *Anopheles gambiae* complex (Diptera, Culicidae). *Bulletin of Entomological Research*, **64**, 241-246.
- Jones, M.D.R., Hill, M. and Hope, A.M. (1967) The circadian flight activity of the mosquito *Anopheles gambiae*: Phase setting by the light regime. *Journal of Experimental Biology*, **47**, 503-511.
- Justus, K.A., Murlis, J., Jones, C. and Cardé, R.T. (2002) Measurement of odor-plume structure in a wind tunnel using a photoionization detector and a tracer gas. *Environmental Fluid Mechanics*, **2**, 115-142.
- Kampango, A., Cuamba, N. and Charlwood, J.D. (2011) Does moonlight influence the biting behaviour of *Anopheles funestus*? *Medical and Veterinary Entomology*, **25**, 240-246.
- Kawada, H., Tatsuta, H., Arikawa, K. and Takagi, M. (2006) Comparative study on the relationship between photoperiodic host-seeking behavioural patterns and the eye parameters of mosquitoes. *Journal of Insect Physiology*, **52**, 67-75.



- Kay, B.H., Sutton, K.A. and Russell, B.M. (2000) A sticky entry-exit trap for sampling mosquitoes in subterranean habitats. *Journal of the American Mosquito Control Association*, **16**, 262-265.
- Kellogg, F.E. (1970) Water vapour and carbon dioxide receptors in *Aedes aegypti*. *Journal of Insect Physiology*, **16**, 99-108.
- Kennedy, J.S. (1940) The visual responses of flying mosquitoes. *Proceedings of the Zoological Society of London (A)*, **109**, 221-242.
- Kennedy, J.S. (1977) Behaviourally discriminating assays of attractants and repellents. In Shorey, H.H. and McKelvey Jr, J.J. (Eds) (1977) *Chemical Control of Insect Behaviour: Theory and Application*, New York, John Wiley. Chapter 13, pp. 215-229.
- Kennedy, J.S. (1978) The concepts of olfactory 'arrestment' and 'attraction'. *Physiological Entomology*, **3**, 91-98.
- Kennedy, J.S. (1983) Zigzagging and casting as a programmed response to wind-borne odour: a review. *Physiological Entomology*, **8**, 109-120.
- Killeen, G.F., McKenzie, F.E., Foy, B.D., Bøgh, C. and Beier, J.C. (2001) The availability of potential hosts as a determinant of feeding behaviours and malaria transmission by African mosquito populations. *Transactions of the Royal Society of Tropical Medicine and Hygiene*, **95**, 469-476.
- Kipyab, P.C., Khaemba, B.M., Mwangangi, J.M. and Mbogo, C.M. (2013) The bionomics of *Anopheles merus* (Diptera: Culicidae) along the Kenyan coast. *Parasites and Vectors*, **6**(37).

- Knols, B.G.J., de Jong, R. and Takken, W. (1995) Differential attractiveness of isolated humans to mosquitoes in Tanzania. *Transactions of the Royal Society of Tropical Medicine and Hygiene*, **89**, 604-606.
- Knols, B.G.J., van Loon, J.J.A., Cork, A., Robinson, R.D., Adam, W., Meijerink, J., de Jong, R. and Takken, W. (1997) Behavioural and electrophysiological responses of the female malaria mosquito *Anopheles gambiae* (Diptera: Culicidae) to Limburger cheese volatiles. *Bulletin of Entomological Research*, **87**, 151-159.
- Knols, B.G.J., Mboera, L.E. and Takken, W. (1999) Electric nets for studying odour-mediated host-seeking behaviour of mosquitoes. *Medical and Veterinary Entomology*, **12**, 116-120.
- Kwiatkowska, R.M., Platt, N., Poupardin, R., Irving, H., Dabiré, R.K., Mitchell, S., Jones, C.M., Diabaté, A., Ranson, H. and Wondji, C.S. (2013) Dissecting the mechanisms responsible for the multiple insecticide resistance phenotype in *Anopheles gambiae* s.s., M form, from Vallée du Kou, Burkina Faso. *Gene*, **519**, 98-106.
- Lacey, E.S. and Cardé, R.T. (2011) Activation, orientation and landing of female *Culex quinquefasciatus* in response to carbon dioxide and odour from human feet: 3-D flight analysis in a wind tunnel. *Medical and Veterinary Entomology*, **25**, 94-103.
- Lacroix, R., Mukabana, W.R., Gouagna, L.C. and Koella, J.C. (2005) Malaria infection increases attractiveness of humans to malaria. *PLoS Biology*, **3**(9).
- Laganier, R., Randimby, F.M., Rajaonarivelo, V. and Robert, V. (2003) Is the Mbita trap a reliable tool for evaluating the density of anopheline vectors in the highlands of Madagascar? *Malaria Journal*, **2**(42).

- Land, M.F. (1997) Visual acuity in insects. *Annual Review of Entomology*, **42**, 147-177.
- Land, M.F., Gibson, G. and Horwood, J. (1997) Mosquito eye design: conical rhabdoms are matched to wide aperture lenses. *Proceedings of the Royal Society B*, **264**, 1183-1187.
- Land, M.F., Gibson, G., Horwood, J. and Zeil, J. (1999) Fundamental differences in the optical structure of the eyes of nocturnal and diurnal mosquitoes. *Journal of Comparative Physiology*, **185**, 91-103.
- Lefèvre, T., Gouagna, L.-C., Dabiré, R., Elguero, E., Fontenille, D., Renaud, F., Costantini, C. and Thomas, F. (2009) Beyond nature and nurture: Phenotypic plasticity in blood-feeding behavior of *Anopheles gambiae* s.s. when humans are not readily accessible. *American Journal of Tropical Medicine and Hygiene*, **81**, 1023-1029.
- Lyimo, I.N. and Ferguson, H.M. (2009) Ecological and evolutionary determinants of host species choice in mosquitoes. *Trends in Parasitology*, **25**, 189-196.
- Lyimo, I.N., Haydon, D.T., Mbina, K.F., Daraja, A.A., Reeve, R. and Ferguson, H.M. (2012) The fitness of African malaria vectors in the presence and limitation of host behaviour. *Malaria Journal*, **11**(425).
- Mafra-Neto, A. and Cardé, R.T. (1998) Rate of realized interception of pheromone pulses in different wind speeds modulates almond moth orientation. *Journal of Comparative Physiology (A)*, **182**, 563-572.
- Maimon, G., Straw, A.D. and Dickenson, M.H. (2008) A simple vision-based algorithm for decision making in flying *Drosophila*. *Current Biology*, **18**, 464-470.

- Maimon, G., Straw, A.D. and Dickenson, M.H. (2010) Active flight increases the gain of visual motion processing in *Drosophila*. *Nature Neuroscience*, **13**, 393-399.
- Marini, F., Caputo, B., Pombi, M., Tarsitani, G. and Della Torre, A. (2010) Study of *Aedes albopictus* dispersal in Rome, Italy, using sticky traps in mark-release-recapture experiments. *Medical and Veterinary Entomology*, **24**, 361-368.
- Mathenge, E.M., Killeen, G.F., Oulo, D.O., Irungu, L.W., Ndegwa, P.N. and Knols, B.G.J. (2002) Development of an exposure-free bednet trap for sampling Afrotropical malaria vectors. *Medical and Veterinary Entomology*, **16**, 67-74.
- Mathenge, E.M., Misiani, G.O., Oulo, D.O., Irungu, L.W., Ndegwa, P.N., Smith, T.A., Killeen, G.F. and Knols, B.G.J. (2005) Comparative performances of the Mbita trap, CDC light trap and the human landing catch in the sampling of *Anopheles arabiensis*, *A. funestus* and culicine species in a rice irrigation in western Kenya. *Malaria Journal*, **4**(7).
- McGavin, G.C. (2003) *Essential Entomology: An Order by Order Introduction*. Oxford, Oxford University Press.
- Meijerink, J., Braks, M.A.H. and van Loon, J.J.A. (2001) Olfactory receptors on the antennae of the malaria mosquito *Anopheles gambiae* are sensitive to ammonia and other sweat-borne components. *Journal of Insect Physiology*, **47**, 455-464.
- Messenger, L.A., Miller, N.P., Adeogun, A.O., Awolola, T.S. and Rowland, M. (2012) The development of insecticide-treated durable wall lining for malaria control: insights from rural and urban populations in Angola and Nigeria. *Malaria Journal*, **11**(332).

- Muir, L.E., Thorne, M.J. and Kay, B.H. (1992) *Aedes aegypti* (Diptera: Culicidae) vision: Spectral sensitivity and other perceptual parameters of the female eye. *Journal of Medical Entomology*, **29**, 278-281.
- Mukabana, W.R., Mweresa, C.K., Otieno, B., Omusula, P., Smallegange, R.C., van Loon, J.J.A. and Takken, W. (2012) A novel synthetic odorant blend for trapping of malaria and other African mosquito species. *Journal of Chemical Ecology*, **38**, 235-244.
- Mukabana, W.R., Takken, W., Killeen, G.F. and Knols, B.G.J. (2007) Clinical malaria reduces human attractiveness to mosquitoes. *Proceedings of the Netherlands Entomological Society Meeting*, **18**, 125-129.
- Murlis, J. and Jones, C.D. (1981) Fine-scale structure of odour plumes in relation to insect orientation to distant pheromone and other attractant sources. *Physiological Entomology*, **6**, 71-86.
- NASA (1969) *Data for advanced space communication and tracking systems*. Goddard Space Flight Centre, NASA Report NAS 5-9637, Volume 4, Prepared by Hughes Aircraft Co., Oct. 1969.
- Njie, M., Dilger, E., Lindsay, S.W. and Kirby, M.J. (2009) Importance of eaves to house entry by Anopheline, but not Culicine, mosquitoes. *Journal of Medical Entomology*, **46**, 505-510.
- Odetoyinbo, J.A. (1969) Preliminary investigation on the use of a light-trap for sampling malaria vectors in The Gambia. *Bulletin of the World Health Organisation*, **40**, 547-560.
- Oduola, A.O. and Awe, O.O. (2006) Behavioural biting preference of *Culex quinquefasciatus* in human host in Lagos metropolis Nigeria. *Journal of Vector Borne Disease*, **43**, 16-20.

- Okumu, F.O., Killeen, G.F., Ogoma, S., Biswaro, L., Smallegange, R.C., Mbeyela, E., Titus, E., Munk, C., Ngonyani, H., Takken, W., Mshinda, H., Mukabana, W.R. and Moore, S. (2010) Development and field evaluation of a synthetic mosquito lure that is more attractive than humans. *PLoS ONE*, **5**(1).
- Olanga, E.A., Okal, M.N., Mbadi, P.A., Kokwaro, E.D. and Mukabana, W.R. (2010) Attraction of *Anopheles gambiae* to odour baits augmented with heat and moisture. *Malaria Journal*, **9**(6).
- Omer, S.M. (1979) Responses of females of *Anopheles arabiensis* and *Culex pipiens fatigans* to air currents, carbon dioxide and human hands in a flight-tunnel. *Entomologia Experimentalis et Applicata*, **26**, 142-151.
- Packer, M.J. and Brady, J. (1990) Efficiency of electric nets as sampling devices for tsetse flies (Diptera: Glossinidae). *Bulletin of Entomological Research*, **80**, 43-47.
- Pates, H.V., Takken, W. and Curtis, C.F. (2005) Laboratory studies on the olfactory behaviour of *Anopheles quadriannulatus*. *Entomologia Experimentalis et Applicata*, **114**, 153-159.
- Pennetier, C., Warren, B., Dabiré, K.R., Russell, I.J. and Gibson, G. (2010) "Singing on the wing" as a mechanism for species recognition in the malarial mosquito *Anopheles gambiae*. *Current Biology*, **20**, 131-136.
- Phyo, A.P., Nkhoma, S., Stepniewska, K., Ashley, E.A., Nair, S., McGready, R., Ier Moo, C., Al-Saai, S., Dondrop, A.M., Lwin, K.M., Singhasivanon, P., Day, N.P.J., White, N.J., Anderson, T.J.C. and Nosten, F. (2012) Emergence of artemisinin-resistant malaria on the western border of Thailand: a longitudinal study. *Lancet*, **379**, 1960-1966.

- Pianka, E.R. (1970) On r- and K-selection. *The American Naturalist*, **104**, 592-597.
- Pile, M.M., Simmonds, M.S.J. and Blaney, W.M. (1991) Odour-mediated upwind flight of *Culex quinquefasciatus* mosquitoes elicited by a synthetic attractant. *Physiological Entomology*, **16**, 77-85.
- Pile, M.M., Simmonds, M.S.J. and Blaney, W.M. (1993) Odour-mediated upwind flight of *Culex quinquefasciatus* mosquitoes elicited by a synthetic attractant: a reappraisal. *Physiological Entomology*, **18**, 219-221.
- Port, G.R., Boreham, P.F.L. and Bryan, J.H. (1980) The relationship of host size to feeding by mosquitoes of the *Anopheles gambiae* Giles complex (Diptera: Culicidae). *Bulletin of Entomological Research*, **70**, 133-144.
- Provost, M.W. (1959) The influence of moonlight on light-trap catches of mosquitoes. *Annals of The Entomological Society of America*, **52**, 261-271.
- Qiu, Y.T., Smallegange, R.C., van Loon, J.J.A., Ter Braak, C.J.F. and Takken, W. (2006) Interindividual variation in the attractiveness of human odours to the malaria mosquito *Anopheles gambiae* s.s. *Medical and Veterinary Entomology*, **20**, 280-287.
- R Development Core Team (2010) R: A language and environment for statistical computing. R Foundation for Statistical Computing, Vienna, Austria.
- Ranson, H., Abdallah, H., Badolo, A., Guelbeogo, W.M., Keraf-Hinzoumbe, C., Yangalbe-Kalnone, E., Sagnon, N., Simard, F. and Coetzee, M.

(2009) Insecticide resistance in *Anopheles gambiae*: data from the first year of a multi-country study highlight the extent of the problem. *Malaria Journal*, **8**(299).

Reddy, M.R., Overgaard, H.J., Abaga, S., Reddy, V.P., Caccone, A., Kiszewski, A.E. and Slotman, M.A. (2011) Outdoor host seeking behaviour of *Anopheles gambiae* mosquitoes following initiation of malaria vector control on Bioko Island, Equatorial Guinea. *Malaria Journal*, **10**(184).

Reisen, W.K. and Aslamkhan, M. (1978) Biting rhythms of some Pakistan mosquitoes (Diptera: Culicidae). *Bulletin of Entomological Research*, **68**, 313-330.

Reiser, M.B. and Dickenson, M.H. (2010) *Drosophila* fly straight by fixating objects in the face of expanding optic flow. *Journal of Experimental Biology*, **213**, 1771-1781.

Riehle, M.M., Guelbeogo, W.M., Gneme, A., Eiglmeier, K., Holm, I., Bischoff, E., Garnier, T., Snyder, G.M., Li, X., Markianos, K., Sagnon, N.F. and Vernick, K.D. (2011) A cryptic subgroup of *Anopheles gambiae* is highly susceptible to human malaria parasites. *Science*, **311**, 1-9.

Rowland, M. (1989) Changes in the circadian flight activity of the mosquito *Anopheles stephensi* associated with insemination, blood-feeding, oviposition and nocturnal light intensity. *Physiological Entomology*, **14**, 77-84.

Rund, S.S., Hou, T.Y., Ward, S.M., Collins, F.H. and Duffield, G.E. (2011) Genome-wide profiling of diel and circadian gene expression in the malaria vector *Anopheles gambiae*. *Proceedings of the National Academy of Sciences of the United States of America*, **108**, E421-E430.



- Russell, T.L., Govella, N.J., Azizi, S., Drakeley, C.J., Patrick Kachur, S. and Killeen, G.F. (2011) Increased proportions of outdoor feeding among residual malaria vector populations following increased use of insecticide-treated nets in rural Tanzania. *Malaria Journal*, **10**(80).
- Sabelis, M.W. and Schippers, P. (1984) Variable wind directions and anemotactic strategies of searching for an odour plume. *Oecologia*, **63**, 225-228.
- Service, M.W. (1980) Effects of wind on the behaviour and distribution of mosquitoes and blackflies. *International Journal of Biometeorology*, **24**, 347-353.
- Shukla, S. (2012) Africa's changing mosquito dynamics. *The Lancet*, **380**, 1130-1131.
- Silver, J.B. (2008) *Mosquito Ecology: Field Sampling Methods*. Dordrecht, The Netherlands, Springer.
- Simard, F., Nchoutpouen, E., Toto, J.C. and Fontenille, D. (2005) Geographic distribution and breeding site preference of *Aedes albopictus* and *Aedes aegypti* (Diptera: culicidae) in Cameroon, Central Africa. *Journal of Medical Entomology*, **42**, 726-31.
- Slaff, M., Haefner, J.D., Parsons, R.E. and Wilson, F. (1984) A modified pyramidal emergence trap for collecting mosquitoes. *Mosquito News*, **44**, 197-199.
- Smallegange, R.C., Qiu, Y.T., Galimard, A.M.S., Posthumus, M.A., van Beek, T.A., van Loon, J.J.A. and Takken, W. (2003) Why humans are attractive to malaria mosquitoes. *Entomologische Berichten*, **63**, 50-53.

- Smallegange, R.C., Qiu, Y.T., van Loon, J.J.A. and Takken, W. (2005) Synergism between ammonia, lactic acid and carboxylic acids as kairomones in the host-seeking behaviour of the malaria mosquito *Anopheles gambiae sensu stricto* (Diptera: Culicidae). *Chemical Senses*, **30**, 145-152.
- Snow, K.R. (1990) *Naturalists' Handbooks 14: Mosquitoes*. Slough, Richmond Publishing Co. Ltd.
- Snow, W.F. (1976) The direction of flight of mosquitoes (Diptera, Culicidae) near the ground in West African savanna in relation to wind direction, in the presence and absence of bait. *Bulletin of Entomological Research*, **65**, 555-562.
- Spitzen, J., Spoor, C.W., Kranenbarg, S., Beeuwkes, J., Grieco, F., Noldus, L.P.J.J., van Leeuwen, J.L. and Takken, W. (2008) Track3D: Visualisation and flight track analysis of *Anopheles gambiae* s.s. mosquitoes. In Spink, A.J., Ballintijn, M.R., Bogers, N.D., Loijens, L.W.S., Noldus, L.P.J.J., Smit, G. and Zimmerman, P.H. (Eds.) (2008) *Proceedings of Measuring Behaviour 2008, The Netherlands, August 26-29, 2008*.
- Stevenson, J., St. Laurent, B., Lobo, N.F., Cooke, M.K., Kahindi, S.C., Oriango, R.M., Harbach, R.E., Cox, J. and Drakeley, C. (2012) Novel vectors of malaria parasites in the Western highlands of Kenya. *Emerging Infectious Diseases*, **18**, 1547-1549.
- Sumba, L.A., Okoth, K., Deng, A.L., Githure, J., Knols, B.G.J., Beier, J.C. and Hassanali, A. (2004) Daily ovipositional patterns of the African malaria mosquito *Anopheles gambiae* Giles (Diptera: Culicidae) on different types of aqueous substrates. *Journal of Circadian Rhythms*, **2**, 1-7.

- Takken, W., Dekker, T. and Wijnholds, Y.G. (1997a) Odour-mediated flight behaviour of *Anopheles gambiae* Giles *sensu stricto* and *Anopheles stephensi* Liston in response to CO<sub>2</sub>, acetone, and 1-octen-3-ol. *Journal of Insect Behaviour*, **10**, 395-407.
- Takken, W., Knols, B.G.J. and Otten, H. (1997b) Interactions between physical and olfactory cues in the host-seeking behaviour of mosquitoes: the role of relative humidity. *Annals of Tropical Medicine and Parasitology*, **91**, S119-S120.
- Takken, W. and Knols, B.G.J. (1990) Flight behaviour of *Anopheles gambiae* Giles (Diptera: Culicidae) in response to host stimuli: a wind tunnel study. *Experimental and Applied Entomology, Proceedings of N.E.V. Amsterdam*, **1**, 121-128.
- Takken, W. and Knols, B.G.J. (1999) Odor-mediated behaviour of Afrotropical malaria mosquitoes. *Annual Review of Entomology*, **44**, 131-157.
- Tirados, I., Esterhuizen, J., Rayaisse, J.B., Diarrassouba, A., Kaba, D., Mpiana, S., Vale, G.A., Solano, P., Lehane, M.J. and Torr, S.J. (2011) How do tsetse recognise their hosts? The role of shape in the responses of tsetse (*Glossina fuscipes* and *G. palpalis*) to artificial hosts. *PLoS Neglected Tropical Diseases*, **5**(8).
- Tirados, I., Gibson, G., Young, S. and Torr, S.J. (2011) Are herders protected by their herds? An experimental analysis of zooprophylaxis against the malaria vector *Anopheles arabiensis*. *Malaria Journal*, **10**(68).
- Torr, S.J. (1988) The activation of resting tsetse flies (*Glossina*) in response to visual and olfactory stimuli in the field. *Physiological Entomology*, **13**, 467-478.

- Torr, S.J. (1994) The tsetse (Diptera: Glossinidae) story: Implications for mosquitoes. *Journal of the American Mosquito Control Association*, **10**, 258-265.
- Torr, S.J., Della Torre, A., Calzetta, M., Costantini, C. and Vale, G.A. (2008) Towards a fuller understanding of mosquito behaviour: use of electrocuting grids to compare the odour-orientated responses of *Anopheles arabiensis* and *An. quadriannulatus* in the field. *Medical and Veterinary Entomology*, **22**, 93-108.
- Vale, G.A. (1974) New field methods for studying the responses of tsetse flies (Diptera, Glossinidae) to hosts. *Bulletin of Entomological Research*, **64**, 199-208.
- Van den Broek, I.V.F. and den Otter, C.J. (1999) Olfactory sensitivities of mosquitoes with different host preferences (*Anopheles gambiae* s.s., *An. arabiensis*, *An. quadriannulatus*, *An. m. atroparvus*) to synthetic host odours. *Journal of Insect Physiology*, **45**, 1001-1010.
- Van der Goes van Naters, W.M., den Otter, C.J. & Maes, F.W. (1998) Olfactory sensitivity in tsetse flies: A daily rhythm. *Chemical Senses*, **23**, 351-357.
- Verhulst, N.O., Beijleveld, H., Knols, B.G.J., Takken, W., Schraa, G., Bouwmeester, H.J. and Smallegange, R.C. (2009) Cultured skin microbiota attracts malaria mosquitoes. *Malaria Journal*, **8**(302).
- Vickers, N.J. (2000) Mechanisms of animal navigation in odour plumes. *Biological Bulletin*, **198**, 203-212.

- Vickers, N.J., Christensen, T.A., Baker, T.C. and Hildebrand, J.G. (2001) Odour-plume dynamics influence the brain's olfactory code. *Nature*, **410**, 466-470.
- Walter Reed Biosystematics Unit (2011) *Mosquito Identification Resources*. Available from <http://www.wrbu.org/VeclDResourcesMQ.html>, accessed November 2011.
- Warrant, E. and Dacke, M. (2011) Vision and visual navigation in nocturnal insects. *Annual Review of Entomology*, **56**, 239-254.
- White, G.B. (1974) *Anopheles gambiae* complex and disease transmission in Africa. *Transactions of the Royal Society of Tropical Medicine and Hygiene*, **68**, 278-298.
- White, G.B. (1985) *Anopheles bwambae* sp. n., a malaria vector in the Semliki Valley, Uganda, and its relationships with other sibling species of the *An. gambiae* complex (Diptera: Culicidae). *Systematic Entomology*, **10**, 501-522.
- Whittaker, R.H. and Feeny, P.P. (1971) Allelochemicals: Chemical interactions between species. *Science*, **171**, 757-770.
- World Health Organization (1975) *Manual on Practical Entomology in Malaria*. Geneva, WHO.
- World Health Organisation (WHO) (2010) *Malaria Fact Sheet No. 94*. Available from <http://www.who.int/mediacentre/factsheets/fs094/en/index.html>, accessed 1 December 2009 and 18 April 2011.

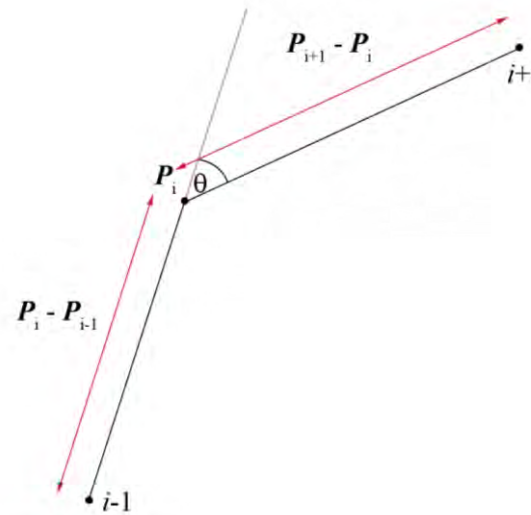
- World Health Organization (2012) *Update on artemisinin resistance – April 2012*. Geneva, WHO.
- Yakob, L. (2011) Epidemiological consequences of a newly discovered cryptic subgroup of *Anopheles gambiae*. *Biology Letters*, **7**, 947-949.
- Yohannes, M. and Boelee, E. (2012) Early biting rhythm in the afro-tropical vector of malaria, *Anopheles arabiensis*, and challenges for its control in Ethiopia. *Medical and Veterinary Entomology*, **26**, 103-105.
- Yorozu, S., Wong, A., Fischer, B.J., Dankert, H., Kernan, M.J., Kamikouchi, A., Ito, K., Anderson, D.J. (2009) Distinct sensory representations of wind and near-field sound in the *Drosophila* brain. *Nature*, **458**, 201-205.
- Young, S., David, C.T. and Gibson, G. (1987) Light measurement for entomology in the field and laboratory. *Physiological Entomology*, **12**, 373-379.
- Zwiebel, L.J. and Takken, W. (2004) Olfactory regulation of mosquito-host interactions. *Insect Biochemistry and Molecular Biology*, **34**, 645-652.

## APPENDIX A: CALCULATIONS FOR TRACK ANALYSIS

Track parameter	Description	Calculation	Unit
Track displacement	Total 3D length of track	$\sum_{i=2}^n  \mathbf{p}_i - \mathbf{p}_{i-1} $ <p><math>\mathbf{p}</math> = position vector  <math>n</math> = number of points</p>	cm
Straight line distance	Distance from start to end of track	$ \mathbf{p}_n - \mathbf{p}_1 $	cm
Three-dimensional tortuosity	Straight line distance divided by track displacement	$\frac{ \mathbf{p}_n - \mathbf{p}_1 }{\sum_{i=2}^n  \mathbf{p}_i - \mathbf{p}_{i-1} }$	0 – 1 index (0 = straight line)
Three-dimensional flight speed	Displacement per second	$\frac{ \mathbf{p}_i - \mathbf{p}_{i-1} }{t_i - t_{i-1}}$ <p><math>t</math> = time</p>	cm s <sup>-1</sup>

**APPENDIX A: CALCULATIONS FOR TRACK ANALYSIS cont.**

Track parameter	Description	Calculation	Unit
Three-dimensional angular velocity	Change in direction per second	$\frac{ \theta_{i+1} - \theta_i }{t_{i+1} - t_i}$	$^{\circ} \text{ s}^{-1}$



$$\theta_i = \text{acos}((P_{i+1} - P_i) \cdot (P_i - P_{i-1}))$$



**APPENDIX A: CALCULATIONS FOR TRACK ANALYSIS cont.**

Track parameter	Description	Calculation	Unit
Three-dimensional track angle	Track angle, relative to constant due upwind vector	$\theta_i = \text{acos} \left( (\mathbf{P}_i - \mathbf{P}_{i-1}) \cdot \mathbf{w} \right)$ $\mathbf{w} = \text{constant wind vector}$	°
Three-dimensional course angle	Course angle, compensating for wind drift. Using the newly calculated points $c_i$ the course angle is derived as in 3D track angle	$\mathbf{c}_i = \mathbf{p}_i - (t_i - t_0)\mathbf{w}$ $c = \text{course point}$	°

## APPENDIX B: THREE-DIMENSIONAL ANIMATED FLIGHT TRACK GRAPHS

Web links can be followed to YouTube for in-browser video viewing; alternatively, videos are included on the enclosed CD, with a copy of VLC Media Player for viewing videos off-line.

### Supplementary material 5a: Smooth, tortuous and dipping tracks in clean air and host odour

Track description	Web link to video
Smooth flight in clean air	<a href="http://youtu.be/hpWIKdLPWSY">http://youtu.be/hpWIKdLPWSY</a>
Smooth flight in host odour	<a href="http://youtu.be/OGMk8dndJ0w">http://youtu.be/OGMk8dndJ0w</a>
Tortuous flight in clean air	<a href="http://youtu.be/7aRMgkdEI24">http://youtu.be/7aRMgkdEI24</a>
Tortuous flight in host odour	<a href="http://youtu.be/c2BNnPOHI-M">http://youtu.be/c2BNnPOHI-M</a>
Dipping flight in clean air	<a href="http://youtu.be/efktmTB0vA0">http://youtu.be/efktmTB0vA0</a>
Dipping flight in host odour	<a href="http://youtu.be/ZbMBM-7Fmmo">http://youtu.be/ZbMBM-7Fmmo</a>

### Supplementary material 6a: Examples of tracks responding and not responding to a target

Track description	Web link to video
Responding track (Fig. 6.2 A)	<a href="http://youtu.be/o1PHdLX83I4">http://youtu.be/o1PHdLX83I4</a>
Non-responding track (Fig. 6.2 B)	<a href="http://youtu.be/Dp9mjU_GhYY">http://youtu.be/Dp9mjU_GhYY</a>
Non-responding track (Fig. 6.3 A)	<a href="http://youtu.be/WUgSXY8EWKI">http://youtu.be/WUgSXY8EWKI</a>
Non-responding track (Fig. 6.3 B)	<a href="http://youtu.be/sM4n5QrpFC8">http://youtu.be/sM4n5QrpFC8</a>

**APPENDIX B: THREE-DIMENSIONAL ANIMATED FLIGHT TRACK  
GRAPHS cont.**

**CD of Supplementary material 5a and 6a**